

Catalogue

Solenoid valves for Industrial Refrigeration

Contents

	Page
2-step solenoid valve, type ICLX 32-150	3
Dual position solenoid valve, type ICSH.	31
Solenoid valves type EVRA and EVRAT	55
Stainless steel solenoid valves, type EVRS 3-20 and EVRST 10-20	73
Solenoid coil, types BB, BE, BF, BG, and BN	87

2-step solenoid valve

Type ICLX 32-150

Contents

	Page
Features	5
The ICLX Concept	6
Design (valve)	6
Approvals	6
Technical data	7
Function	8
Selection of ICLX valve	11
Nominal capacities	11
Ordering from the parts programme	21
Accessories	25
Dimensions	28
Connections	30

2-step solenoid valve

Type ICLX 32-150



ICLX 2-step solenoid valves belong to the ICV family.

ICLX are used in suction lines for the opening against high differential pressure, e.g. after hot gas defrost in large industrial refrigeration systems with ammonia, fluorinated refrigerants or CO₂.

The ICLX valve is factory configured to open in 2 steps.

By following a simple procedure the valve can be configured to open in 1 step only.

In 2-step configuration, step 1 opens to approx. 10% of the capacity after the pilot solenoid valves are energized.

Step 2 opens automatically when the pressure differential across the valve has decreased to approx. 1.25 bar / 18 psig.

The ICLX valve comprises five main components: Valve body, top cover, function module and 2 pilot solenoid valves. On ICLX 32 – 150 the top cover and function module are factory-assembled.

Features

- Designed for Industrial Refrigeration applications for a maximum working pressure of 52 bar g / 754 psig.
- Applicable to HCFC, HFC, R717 (Ammonia) and R744 (CO₂).
- Can be used in chemical and petro-chemical applications.
- Direct welded connections.
- Connection types include butt weld, socket weld and solder connections.
- Low temperature steel body.
- Low weight and compact design.
- Only one signal required for both pilot solenoid valves.
- The ICLX main valve top cover can be oriented in any direction without the function of pilot valves being affected.
- Especially suitable for systems where low pressure drop is required.
- Stabilizes working conditions and eliminates pressure pulsations during opening after defrosting.
- Provides safety against pressure "shocks" as the valve can only open fully when $\Delta p < 1.25 \text{ bar} / 18 \text{ psig}$.
- Cavitation resistant valve seat.
- Manual opening possible.
- PTFE seat provides excellent valve tightness.
- Service friendly design.
- Classification: DNV, CRN, BV, EAC etc.
To get an updated list of certification on the products please contact your local Danfoss Sales Company.

2-step solenoid valve, type ICLX 32-150

Approvals
The ICV valve concept is designed to fulfil global refrigeration requirements.

The Factory assembled ICLX is CE and UL approved. For specific approval information, please contact Danfoss.



ICLX valves			
Nominal bore	DN ≤ 25 (1 in.)	DN 32 – 65 (1 ¼ – 2 ½ in.)	DN 80 – 150 (3 – 6 in.)
Classified for	Fluid group I		
Category	Article 3, paragraph 3	II	III

The ICLX Concept

The ICLX concept is developed to highest flexibility of direct welded connections. For valve sizes ICV 32 – ICV 65 a wide range of connection sizes and types is available. ICV 100 – ICV 150 are

available in butt-weld DIN and butt-weld ANSI nominal sizes. The direct welded (non-flanged) connections secures low risk of leakage.

- There are seven valve bodies available.

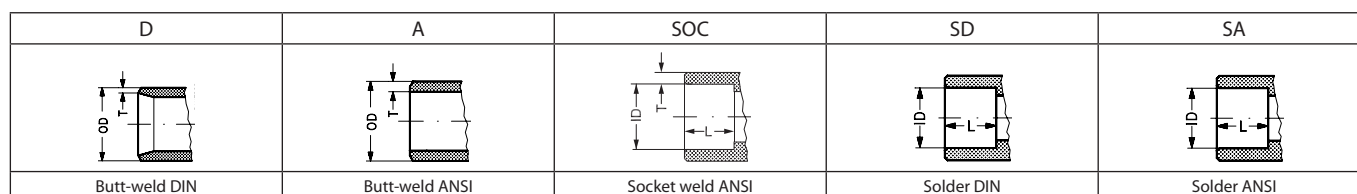
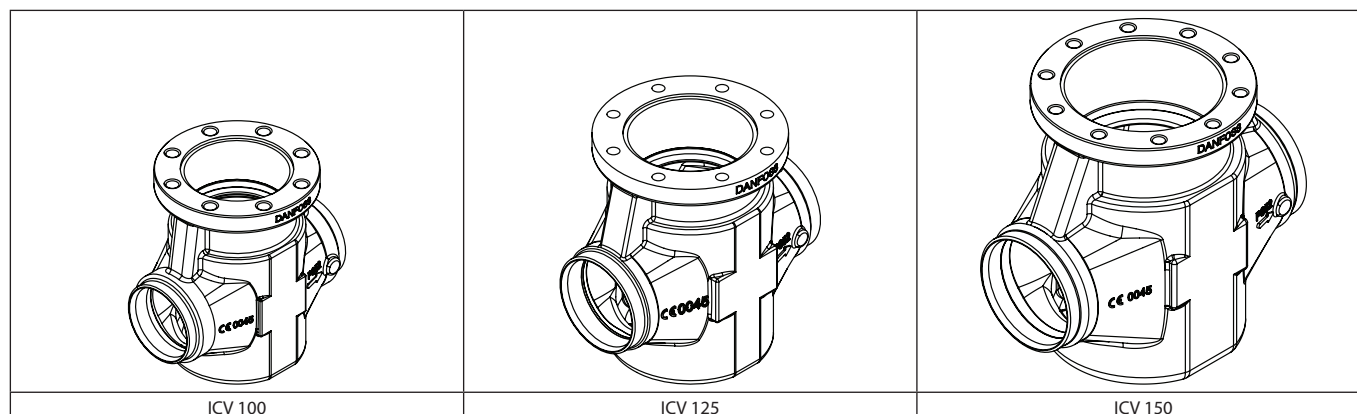
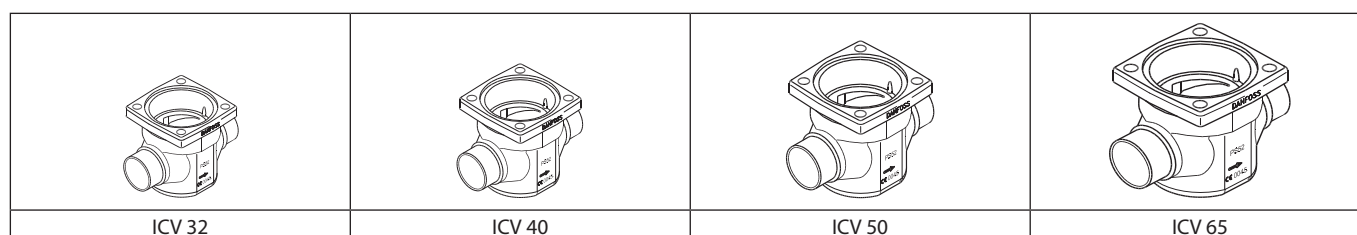

Design (valve)

Connections
There is a very wide range of connection types available with ICLX valves:

- D: Butt weld, EN 10220
- A: Butt weld, ANSI (B 36.10)
- SOC: Socket weld, ANSI (B 16.11)
- SD: Solder connection, EN 1254-1
- SA: Solder connection, ANSI (B 16.22)

The ICLX valves are approved in accordance with the European standard specified in the Pressure Equipment Directive and are CE marked. For further details / restrictions - see Installation Instruction.

Valve body and top cover material
Low temperature steel

2-step solenoid valve, type ICLX 32-150

Technical data

- *Refrigerants*
Applicable to HCFC, HFC, R717 (Ammonia) and R744 (CO₂).
Temperature range:
Media: -60 – 120 °C / -76 – 248 °F.
 - *Pressure*
The valve is designed for a max. working pressure of 52 bar g / 754 psi g
 - *Surface protection*
The ICLX external surface is zinc-chromated to provide good corrosion protection.
 - *Max. opening pressure differential (MOPD):*
ICLX 32 – 150
21 bar / 305 psi @ external pressure 1.5 bar / 22 psi higher than inlet pressure of the valve.
- ICLX 32-150
40 bar / 580 psi @ external pressure 2 bar (30 psi) higher than inlet pressure of the valve.
- Coil requirements:*
Both coils to be IP67.
EVM NC:
10W AC (or higher) for MOPD up to 21 bar
EVM NC:
20W AC for MOPD 21 – 40 bar
EVM NO:
10W AC (or higher)

	ICLX 32	ICLX 40	ICLX 50	ICLX 65	ICLX 100	ICLX 125	ICLX 150
K _v (m ³ /h)	22	29	47	82	151	225	390
C _v (USgal/min)	25.5	33.6	54.5	95	175	261	452

2-step solenoid valve, type ICLX 32-150

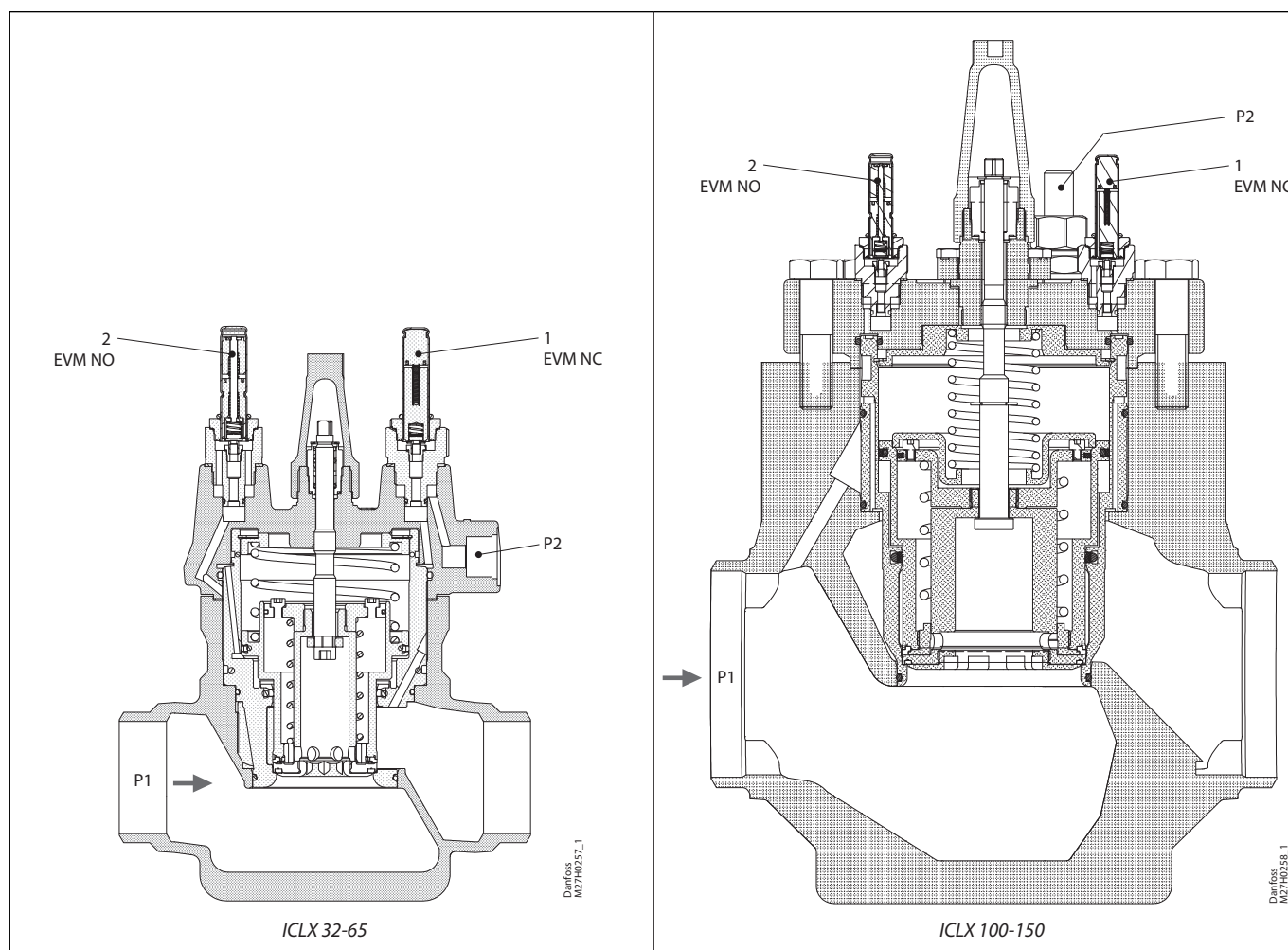

Function

The ICLX valve is used as a shut-off valve in suction lines to open after hot gas defrost.

The valve is a pilot controlled valve operated by an external pilot pressure source. This means that the valve can operate with no internal pressure differential (P_d) at all.

Low P_d is the key objective and makes the ICLX valve ideal for applications that are sensitive to differential pressure.

Though P_d is kept low, it can still be quantified, and must be considered when choosing valve size. See section - Selection of ICLX valve - for the impact.

The main valve is provided with two pilot solenoid valves, as well as a nipple for connection to external pilot pressure.

The external pilot pressure line must be connected to a system pressure (p_2) which is at least 1.5 bar / 20 psi higher than the inlet pressure (p_1) of the valve. The difference between the external pilot pressure and the inlet pressure of the valve defines the maximum opening differential pressure (MOPD) of the ICLX.

The ICLX is kept open when power is applied to the coils placed on the EVM pilot solenoid valves pos. 1 and pos. 2.

The ICLX is closing and kept closed when the coils on EVM pilot solenoid valves pos. 1 and pos. 2 are de-energised.

The pilot solenoid valve (pos.1) allows external pilot pressure (p_2) to the bottom of the servo piston and thus opens the first step corresponding to approx. 10% of the valve capacity. At the same time the bleed spring will be compressed. This will start a pressure equalization of the inlet pressure (p_1) to the outlet pressure. When the differential pressure across the valve has fallen to approx. 1.25 bar / 18 psig the spring will be strong enough to open the second step and open the valve for full capacity.

This way high-pressure pulsations, which would occur when opening for full capacity in one step, can be avoided.

ICLX must not be used in pipe systems where the differential pressure across the main valve in open position can exceed 1 bar / 15 psig, otherwise the step two on the valve will close.

2-step solenoid valve, type ICLX 32-150

Function (continued)

Two step opening principle

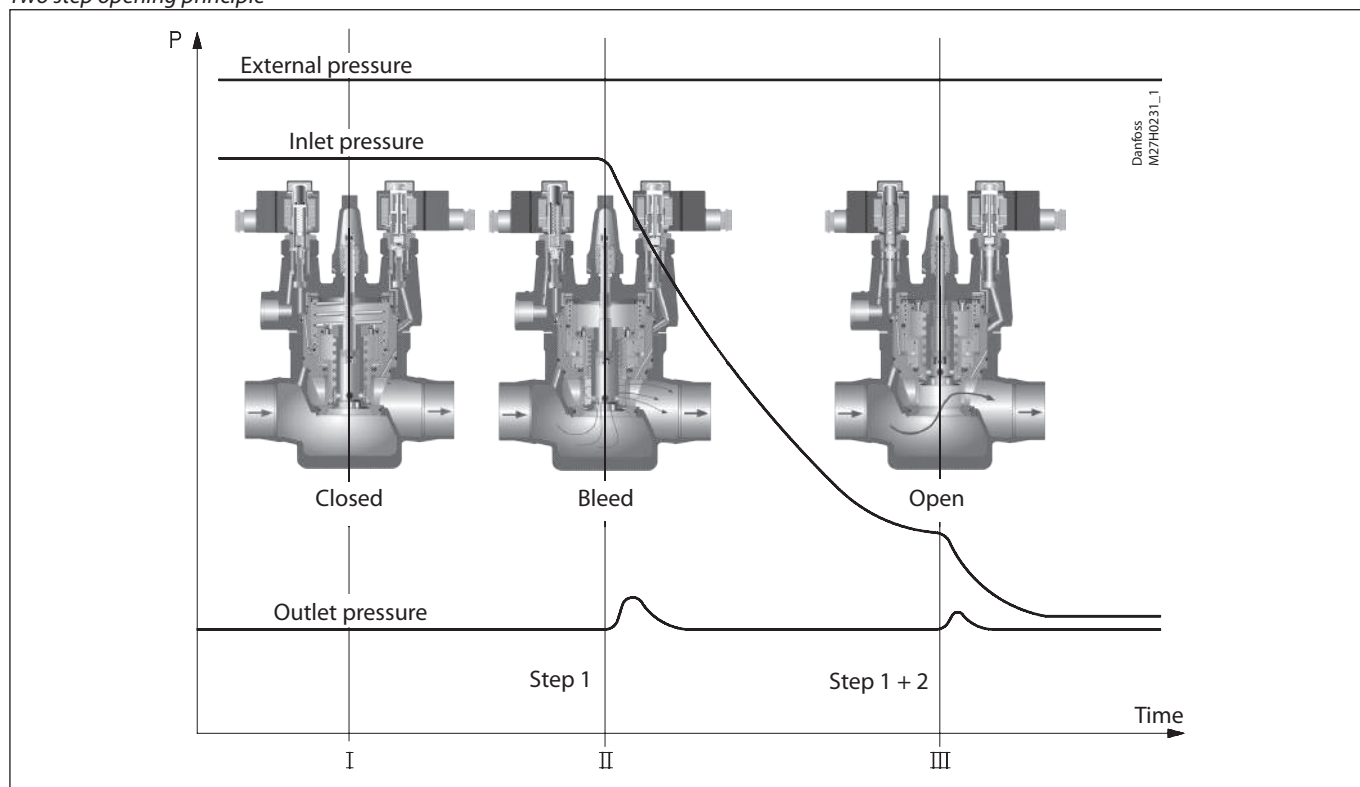

Important note for ICLX valves:
The ICLX valve is kept in its open position by hot gas. The hot gas condenses in the cold valve and creates liquid under the servo piston. When the pilot valves change status to close the ICLX, the pressure on the servo piston equalises with the suction pressure through the pilot valve (pos. 2). This equalisation takes time because condensed liquid is present in the valve.

The exact time taken from when the pilot valves change position to complete closing of the ICLX will depend on temperature, pressure, refrigerant and size of valve. Thus an exact closing time for the valves cannot be given but, in general, lower temperatures give longer closing times.

It is very important to take the closing times into consideration when hot gas defrost is performed on evaporators.

Steps must be taken to ensure that the hot gas supply valve is not opened before the ICLX in the suction line is completely closed. If the hot gas supply valve is opened before the ICLX in the suction line is closed, considerable energy will be lost and potentially dangerous situations might arise because of "liquid hammer". In ICLX valves, the spring-loaded second stage might be induced to hammer by gas and liquid being forced through the valve at $\Delta p > 1.5$ bar across the ICLX. The final result could be severe damage to the valve.

As a rule of thumb a closing time of 2 minutes can be used as a starting point. The optimum closing time for each individual system must be determined at initial start-up of the plant at intended operational conditions. It is recommended to check if the closing time needs to be changed when conditions changes (suction pressure, ambient temp. etc.) and closing time should be checked at service of the valve. Once the optimum closing time has been identified it is recommended to add a safety margin of 30 sec. to the optimum closing time.

2-step solenoid valve, type ICLX 32-150

Material specification

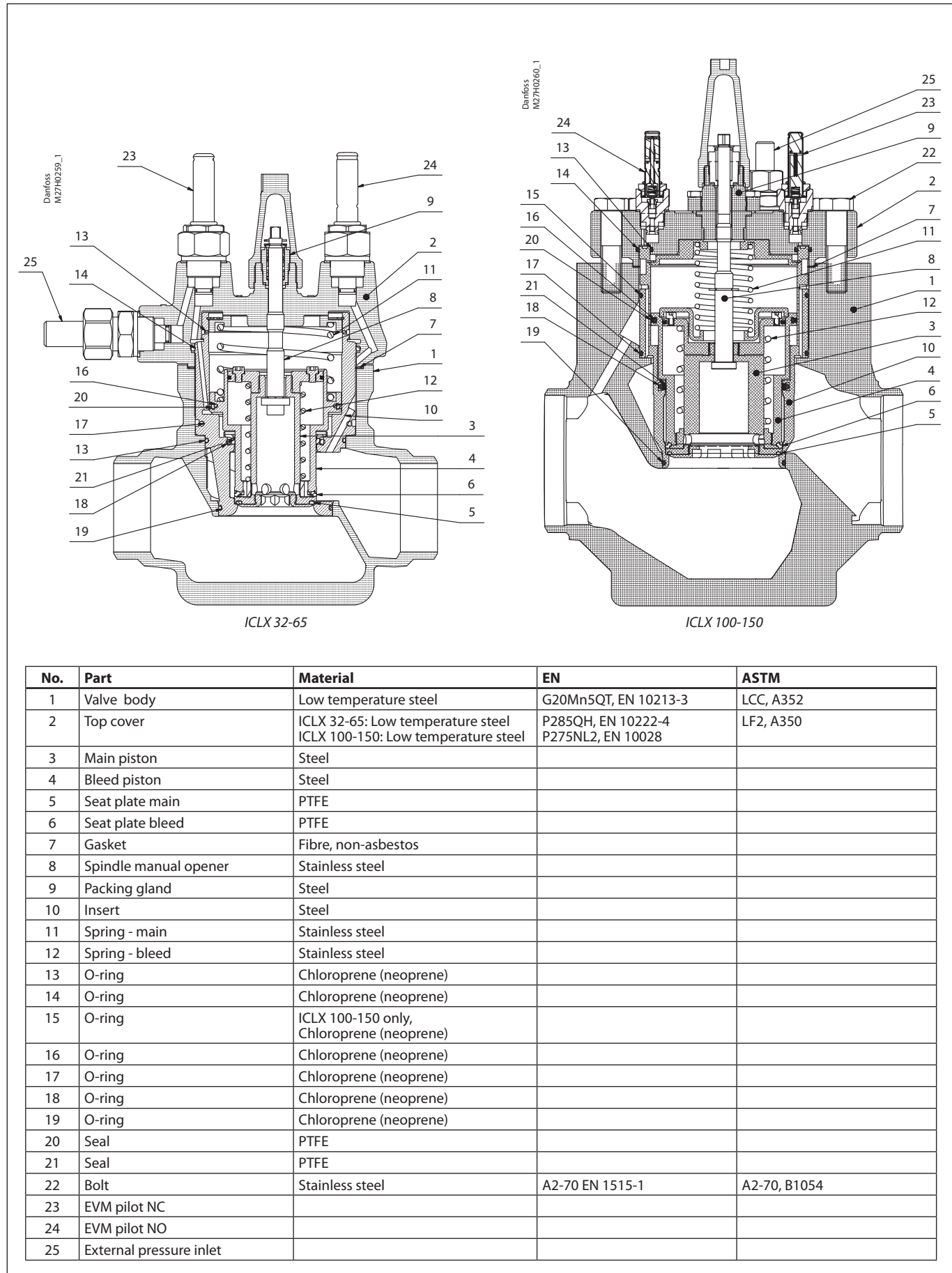

Selection of ICLX valve

Wet suction line

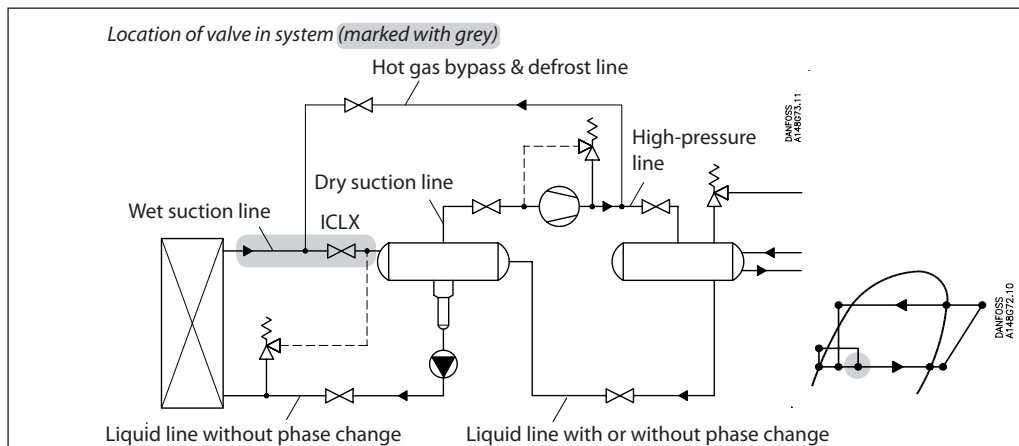

Nominal capacities

Wet suction line

SI units

Calculation example (R 717 capacities):

Running conditions in a plant are as follows:

- $T_e = -20\text{ °C}$
- $Q_0 = 100\text{ kW}$
- Circulation ratio = 3
- Max. $\Delta P = 0.1\text{ bar}$

The capacity table is based on nominal conditions (pressure drop $\Delta P = 0.05\text{ bar}$, circulation ratio = 4).

The actual capacity must therefore be corrected to a nominal condition by multiplication with correction factors.

Correction factor for $\Delta P = 0.1\text{ bar}$, $f_{\Delta P} = 0.71$
 Correction factor for circulation ratio, $f_{\text{circ}} = 0.9$

$$Q_n = Q_0 \times f_{\Delta P} \times f_{\text{circ}} = 100 \times 0.71 \times 0.9 = 63.9\text{ kW.}$$

From the capacity table a ICLX 50 with $Q_n = 84\text{ kW}$ is selected.

US units

Calculation example (R 717 capacities):

Running conditions in a plant are as follows:

- $T_e = -20\text{ °F}$
- $Q_0 = 10\text{ TR}$
- Circulation ratio = 3
- Max. $\Delta P = 1.25\text{ psi}$

The capacity table is based on nominal conditions (pressure drop $\Delta P = 0.75\text{ psi}$, circulation ratio = 4).

The actual capacity must therefore be corrected to a nominal condition by multiplication with correction factors.

Correction factor for $\Delta P = 1.25\text{ psi}$, $f_{\Delta P} = 0.77$
 Correction factor for circulation ratio, $f_{\text{circ}} = 0.9$

$$Q_n = Q_0 \times f_{\Delta P} \times f_{\text{circ}} = 10 \times 0.77 \times 0.9 = 6.9\text{ TR}$$

From the capacity table a ICLX 32 with $Q_n = 9.4\text{ TR}$ is selected.

2-step solenoid valve, type ICLX 32-150

Nominal capacities

Wet suction line

SI units

Capacity table for nominal conditions, Q_N [kW], circulation ratio = 4, $\Delta P = 0.05$ bar

R 717

Type	k_v m ³ /h	Evaporating temperature T_e							
		-50 °C	-40 °C	-30 °C	-20 °C	-10 °C	0 °C	10 °C	20 °C
ICLX 32	22	20	26	32	39	47	55	63	72
ICLX 40	29	27	34	43	52	62	72	83	95
ICLX 50	47	43	56	69	84	100	117	135	153
ICLX 65	83	76	99	122	148	177	207	238	271
ICLX 100	151	138	179	222	270	322	377	433	493
ICLX 125	225	206	267	331	402	480	561	645	734
ICLX 150	390	357	463	574	697	831	973	1118	1273

Correction factor for ΔP ($f_{\Delta P}$)

ΔP (bar)	Correction factor
0.01	2.24
0.03	1.29
0.05	1
0.08	0.79
0.10	0.71
0.14	0.60

Correction factor for circulation ratio (f_{circ})

Circulation ratio	Correction factor
2	0.77
3	0.90
4	1
6	1.13
8	1.20
10	1.25

US units

Capacity table for nominal conditions, Q_N [Tons of Refrigeration], circulation ratio = 4, $\Delta P = 0.75$ psi

R 717

Type	C_v USgal/min	Evaporating temperature T_e							
		-60 °F*	-40 °F	-20 °F	0 °F	20 °F	40 °F	60 °F	80 °F
ICLX 32	26	5.5	7.4	9.4	12	14	17	19	22
ICLX 40	34	7.3	9.8	12	15	19	22	25	29
ICLX 50	55	12	16	20	25	30	36	41	48
ICLX 65	96	21	28	35	44	53	63	73	84
ICLX 100	175	38	51	65	80	97	114	132	153
ICLX 125	261	57	76	96	119	144	170	197	228
ICLX 150	452	98	132	167	206	250	295	342	396

* 2°F below min. operating temperature.

Correction factor for ΔP ($f_{\Delta P}$)

ΔP (psi)	Correction factor
0.15	2.24
0.45	1.29
0.75	1
1.25	0.77
1.75	0.65
2.25	0.58

Correction factor for circulation ratio (f_{circ})

Circulation ratio	Correction factor
2	0.77
3	0.90
4	1
6	1.13
8	1.20
10	1.25

2-step solenoid valve, type ICLX 32-150

Nominal capacities

Wet suction line

R 744

SI units

Capacity table for nominal conditions, Q_N [kW], circulation ratio = 4, $\Delta P = 0.05$ bar

Type	k_v m ³ /h	Evaporating temperature T_e						
		-50 °C	-40 °C	-30 °C	-20 °C	-10 °C	0 °C	10 °C
ICLX 32	22	34	38	43	48	51	54	54
ICLX 40	29	44	50	57	63	68	71	71
ICLX 50	47	72	82	93	102	110	115	115
ICLX 65	83	126	145	164	180	193	202	203
ICLX 100	151	230	263	298	328	352	368	370
ICLX 125	225	343	392	443	488	524	548	552
ICLX 150	390	594	679	768	846	909	951	956

Correction factor for ΔP ($f_{\Delta P}$)

ΔP (bar)	Correction factor
0.01	2.24
0.03	1.29
0.05	1
0.08	0.79
0.10	0.71
0.14	0.60

Correction factor for circulation ratio (f_{circ})

Circulation ratio	Correction factor
2	0.77
3	0.90
4	1
6	1.13
8	1.20
10	1.25

R 744

US units

Capacity table for nominal conditions, Q_N [Tons of Refrigeration], circulation ratio = 4, $\Delta P = 0.75$ psi

Type	C_v USgal/min	Evaporating temperature T_e						
		-60 °F*	-40 °F	-20 °F	0 °F	20 °F	40 °F	60 °F
ICLX 32	26	9.4	10.9	12.5	14	15	15	15
ICLX 40	34	12.4	14.4	16	18	20	20	20
ICLX 50	55	20	23	27	30	32	33	32
ICLX 65	96	35	41	47	52	56	58	56
ICLX 100	175	65	75	86	95	102	106	102
ICLX 125	261	96	111	128	141	152	157	153
ICLX 150	452	167	193	221	245	263	273	264

* 2°F below min. operating temperature.

Correction factor for ΔP ($f_{\Delta P}$)

ΔP (psi)	Correction factor
0.15	2.24
0.45	1.29
0.75	1
1.25	0.77
1.75	0.65
2.25	0.58

Correction factor for circulation ratio (f_{circ})

Circulation ratio	Correction factor
2	0.77
3	0.90
4	1
6	1.13
8	1.20
10	1.25

2-step solenoid valve, type ICLX 32-150

Nominal capacities

Wet suction line

SI units

Capacity table for nominal conditions, Q_N [kW], circulation ratio = 4, $\Delta P = 0.05$ bar

R 134a

Type	k_v m ³ /h	Evaporating temperature T_e						
		-40 °C	-30 °C	-20 °C	-10 °C	0 °C	10 °C	20 °C
ICLX 32	22	9	11	13	15	18	20	22
ICLX 40	29	11	14	17	20	23	26	30
ICLX 50	47	18	23	27	32	38	43	48
ICLX 65	83	33	40	49	57	66	75	84
ICLX 100	151	59	73	88	104	121	137	154
ICLX 125	225	88	109	132	155	180	204	229
ICLX 150	390	153	189	228	269	311	354	397

Correction factor for ΔP ($f_{\Delta P}$)

ΔP (bar)	Correction factor
0.01	2.24
0.03	1.29
0.05	1
0.08	0.79
0.10	0.71
0.14	0.60

Correction factor for circulation ratio (f_{circ})

Circulation ratio	Correction factor
2	0.77
3	0.90
4	1
6	1.13
8	1.20
10	1.25

US units

Capacity table for nominal conditions, Q_N [Tons of Refrigeration], circulation ratio = 4, $\Delta P = 0.75$ psi

R 134a

Type	C_v USgal/min	Evaporating temperature T_e						
		-40 °F	-20 °F	0 °F	20 °F	40 °F	60 °F	80 °F
ICLX 32	26	2.5	3.1	4	5	5	6	7
ICLX 40	34	3.2	4	5	6	7	8	9
ICLX 50	55	5	7	8	10	11	13	15
ICLX 65	96	9	12	14	17	20	23	26
ICLX 100	175	17	21	26	31	36	42	47
ICLX 125	261	25	32	39	46	54	62	70
ICLX 150	452	44	55	67	80	94	107	121

* 2°F below min. operating temperature.

Correction factor for ΔP ($f_{\Delta P}$)

ΔP (psi)	Correction factor
0.15	2.24
0.45	1.29
0.75	1
1.25	0.77
1.75	0.65
2.25	0.58

Correction factor for circulation ratio (f_{circ})

Circulation ratio	Correction factor
2	0.77
3	0.90
4	1
6	1.13
8	1.20
10	1.25

2-step solenoid valve, type ICLX 32-150

Nominal capacities

Wet suction line

R 404A

SI units

Capacity table for nominal conditions, Q_N [kW], circulation ratio = 4, $\Delta P = 0.05$ bar

Type	k_v m ³ /h	Evaporating temperature T_e							
		-50 °C	-40 °C	-30 °C	-20 °C	-10 °C	0 °C	10 °C	20 °C
ICLX 32	22	10	12	14	17	19	22	24	26
ICLX 40	29	13	16	19	22	25	29	31	34
ICLX 50	47	22	26	31	36	41	46	51	55
ICLX 65	83	38	46	55	64	73	82	90	98
ICLX 100	151	70	84	99	116	132	149	164	178
ICLX 125	225	104	125	148	172	197	221	244	265
ICLX 150	390	180	217	257	299	342	384	424	460

Correction factor for ΔP ($f_{\Delta P}$)

ΔP (bar)	Correction factor
0.01	2.24
0.03	1.29
0.05	1
0.08	0.79
0.10	0.71
0.14	0.60

Correction factor for circulation ratio (f_{circ})

Circulation ratio	Correction factor
2	0.77
3	0.90
4	1
6	1.13
8	1.20
10	1.25

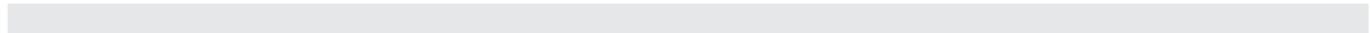

US units

Capacity table for nominal conditions, Q_N [Tons of Refrigeration], circulation ratio = 4, $\Delta P = 0.75$ psi

R 404A

Type	C_v USgal/min	Evaporating temperature T_e							
		-60 °F*	-40 °F	-20 °F	0 °F	20 °F	40 °F	60 °F	80 °F
ICLX 32	26	2.8	3.5	4.2	5	6	6	7	8
ICLX 40	34	3.7	4.6	6	7	8	8	9	10
ICLX 50	55	6	7	9	11	12	14	15	17
ICLX 65	96	11	13	16	19	22	24	27	29
ICLX 100	175	19	24	29	34	39	44	49	53
ICLX 125	261	29	36	43	51	58	66	73	79
ICLX 150	452	50	62	74	88	101	114	126	137

* 2°F below min. operating temperature.

Correction factor for ΔP ($f_{\Delta P}$)

ΔP (psi)	Correction factor
0.15	2.24
0.45	1.29
0.75	1
1.25	0.77
1.75	0.65
2.25	0.58

Correction factor for circulation ratio (f_{circ})

Circulation ratio	Correction factor
2	0.77
3	0.90
4	1
6	1.13
8	1.20
10	1.25

Nominal capacities

Dry suction line

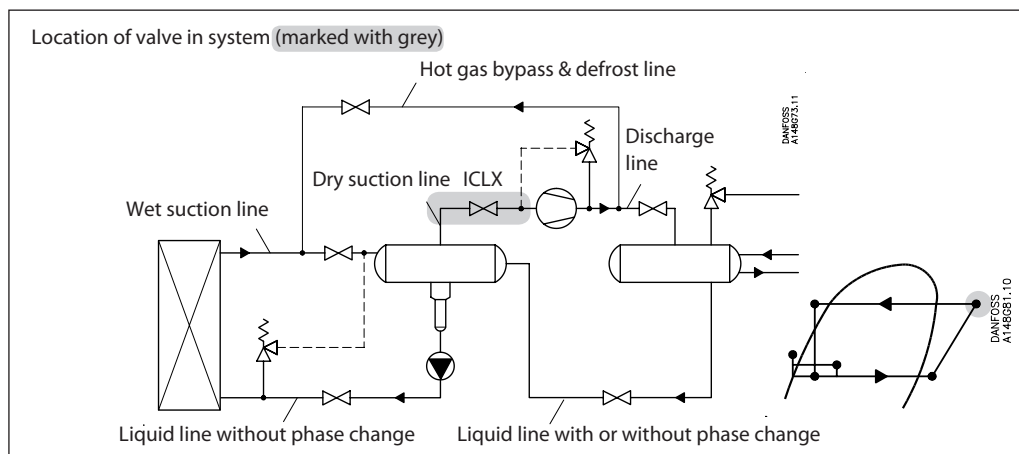

Nominal capacities

Dry suction line

SI units

Calculation example (R 717 capacities):

Running conditions in a plant are as follows:

- $T_e = -20\text{ °C}$
- $Q_0 = 100\text{ kW}$
- $T_{liq} = 10\text{ °C}$
- Max. $\Delta P = 0.1\text{ bar}$

The capacity table is based on nominal conditions (pressure drop $\Delta P = 0.05\text{ bar}$, $T_{liq} = 30\text{ °C}$).

The actual capacity must therefore be corrected to a nominal condition by multiplication with correction factors.

Correction factor for $\Delta P = 0.1\text{ bar}$, $f_{\Delta P} = 0.71$
 Correction factor for liquid temperature, $f_{Tliq} = 0.92$

Correction factor for superheat (T_s) = 1.0
 $Q_n = Q_0 \times f_{\Delta P} \times f_{Tliq} \times f_{T_s}$
 $= 100 \times 0.71 \times 0.92 \times 1.0 = 65.3\text{ kW}$

From the capacity table a ICLX 40 with $Q_n = 79\text{ kW}$ is selected.

US units

Calculation example (R 717 capacities):

Running conditions in a plant are as follows:

- $T_e = 0\text{ °F}$
- $Q_0 = 30\text{ TR}$
- $T_{liq} = 50\text{ °F}$
- Max. $\Delta P = 1.25\text{ psi}$

The capacity table is based on nominal conditions (pressure drop $\Delta P = 0.75\text{ psi}$, $T_{liq} = 90\text{ °F}$).

The actual capacity must therefore be corrected to a nominal condition by multiplication with correction factors.

Correction factor for $\Delta P = 1.25\text{ psi}$, $f_{\Delta P} = 0.77$
 Correction factor for liquid temperature, $f_{Tliq} = 0.92$

Correction factor for superheat (T_s) = 1.0
 $Q_n = Q_0 \times f_{\Delta P} \times f_{Tliq} \times f_{T_s}$
 $= 30 \times 0.77 \times 0.92 \times 1.0 = 21.25\text{ TR}$

From the capacity table a ICLX 40 with $Q_n = 24\text{ TR}$ is selected.

2-step solenoid valve, type ICLX 32-150

Nominal capacities

Dry suction line

R 717

SI units

Capacity table for nominal conditions, Q_N [kW],
 $T_{liq} = 30\text{ }^\circ\text{C}$,
 $\Delta P = 0.05\text{ bar}$
 Superheat = 8K

Type	k_v m ³ /h	Evaporating temperature T_e							
		-50 °C	-40 °C	-30 °C	-20 °C	-10 °C	0 °C	10 °C	20 °C
ICLX 32	22	28	37	48	60	74	90	108	127
ICLX 40	29	37	49	63	79	98	119	142	168
ICLX 50	47	61	80	103	129	159	193	230	272
ICLX 65	83	107	141	181	227	280	340	407	481
ICLX 100	151	195	257	330	414	510	619	740	875
ICLX 125	225	290	383	491	616	760	922	1103	1304
ICLX 150	390	503	663	851	1069	1317	1598	1912	2259

Correction factor for ΔP ($f_{\Delta P}$)

ΔP (bar)	Correction factor
0.01	2.24
0.03	1.29
0.05	1
0.08	0.79
0.10	0.71
0.14	0.60

Correction factor for liquid temperature (T_{liq})

Liquid temperature (°C)	Correction factor
-20	0.82
-10	0.86
0	0.88
10	0.92
20	0.96
30	1
40	1.04
50	1.09

US units

Capacity table for nominal conditions, Q_N [Tons of Refrigeration],
 $T_{liq} = 90\text{ }^\circ\text{F}$,
 $\Delta P = 0.75\text{ psi}$
 Superheat = 12°F

R 717

Type	C_v USgal/min	Evaporating temperature T_e							
		-60 °F*	-40 °F	-20 °F	0 °F	20 °F	40 °F	60 °F	80 °F
ICLX 32	26	7.8	10.6	14.0	18	23	28	34	40
ICLX 40	34	10.3	14.0	18	24	30	37	44	53
ICLX 50	55	17	23	30	38	48	59	72	86
ICLX 65	96	30	40	53	68	85	105	127	152
ICLX 100	175	54	73	96	123	155	191	231	276
ICLX 125	261	80	109	143	184	231	284	345	412
ICLX 150	452	139	189	248	319	400	493	598	713

* 2°F below min. operating temperature.

Correction factor for ΔP ($f_{\Delta P}$)

ΔP (psi)	Correction factor
0.15	2.24
0.45	1.29
0.75	1
1.25	0.77
1.75	0.65
2.25	0.58

Correction factor for liquid temperature (T_{liq})

Liquid temperature (°F)	Correction factor
-10	0.82
10	0.85
30	0.88
50	0.92
70	0.96
90	1
110	1.04
130	1.09

2-step solenoid valve, type ICLX 32-150

Nominal capacities

Dry suction line

R 744

SI units

Capacity table for nominal conditions, Q_N [kW],

$T_{liq} = 10\text{ }^\circ\text{C}$,
 $\Delta P = 0.05\text{ bar}$
 Superheat = 8K

Type	k_v m ³ /h	Evaporating temperature T_e						
		-50 °C	-40 °C	-30 °C	-20 °C	-10 °C	0 °C	10 °C
ICLX 32	22	38	47	56	67	78	89	102
ICLX 40	29	50	62	74	88	103	118	134
ICLX 50	47	82	101	120	142	166	191	217
ICLX 65	83	144	178	213	251	293	337	383
ICLX 100	151	263	324	387	457	534	614	697
ICLX 125	225	391	482	577	681	795	915	1039
ICLX 150	390	678	836	1000	1181	1379	1585	1801

Correction factor for ΔP ($f_{\Delta P}$)

ΔP (bar)	Correction factor
0.01	2.24
0.03	1.29
0.05	1
0.08	0.79
0.1	0.71
0.14	0.6

Correction factor for liquid temperature (T_{liq})

Liquid temperature (°C)	Correction factor
-20	0.75
-10	0.81
0	0.89
10	1
15	1.08

R 744

US units

Capacity table for nominal conditions, Q_N [Tons of Refrigeration],

$T_{liq} = 50\text{ }^\circ\text{F}$,
 $\Delta P = 0.75\text{ psi}$
 Superheat = 12°F

Type	C_v USgal/min	Evaporating temperature T_e						
		-60 °F*	-40 °F	-20 °F	0 °F	20 °F	40 °F	60 °F
ICLX 32	26	10.6	13.4	16.3	20	23	27	31
ICLX 40	34	13.9	17.7	22	26	31	36	41
ICLX 50	55	23	29	35	42	50	58	66
ICLX 65	96	40	51	62	74	87	102	117
ICLX 100	175	73	92	112	135	159	185	213
ICLX 125	261	108	137	167	201	237	276	317
ICLX 150	452	188	238	290	348	411	478	549

* 2°F below min. operating temperature.

Correction factor for ΔP ($f_{\Delta P}$)

ΔP (psi)	Correction factor
0.15	2.24
0.45	1.29
0.75	1
1.25	0.77
1.75	0.65
2.25	0.58

Correction factor for liquid temperature (T_{liq})

Liquid temperature (°F)	Correction factor
-10	0.73
10	0.80
30	0.89
50	1
60	1.08

2-step solenoid valve, type ICLX 32-150

Nominal capacities

Dry suction line

R 134a

SI units

Capacity table for nominal conditions, Q_N [kW],
 $T_{liq} = 30\text{ }^\circ\text{C}$,
 $\Delta P = 0.05\text{ bar}$
 Superheat = 8K

Type	k_v m ³ /h	Evaporating temperature T_e						
		-40 °C	-30 °C	-20 °C	-10 °C	0 °C	10 °C	20 °C
ICLX 32	22	10	13	16	21	26	31	38
ICLX 40	29	13	17	21	27	34	41	50
ICLX 50	47	20	27	35	44	55	67	82
ICLX 65	83	36	47	61	78	97	119	144
ICLX 100	151	65	86	112	141	176	216	262
ICLX 125	225	98	129	167	211	262	322	390
ICLX 150	390	169	223	289	365	454	558	676

Correction factor for ΔP ($f_{\Delta P}$)

ΔP (bar)	Correction factor
0.01	2.24
0.03	1.29
0.05	1
0.08	0.79
0.10	0.71
0.14	0.60

Correction factor for liquid temperature (T_{liq})

Liquid temperature (°C)	Correction factor
-20	0.66
-10	0.70
0	0.76
10	0.82
20	0.90
30	1
40	1.13
50	1.29

R 134a

US units

Capacity table for nominal conditions, Q_N [Tons of Refrigeration],
 $T_{liq} = 90\text{ }^\circ\text{F}$,
 $\Delta P = 0.75\text{ psi}$
 Superheat = 12°F

Type	C_v USgal/min	Evaporating temperature T_e						
		-40 °F	-20 °F	0 °F	20 °F	40 °F	60 °F	80 °F
ICLX 32	26	2.7	3.7	5	6	8	10	12
ICLX 40	34	3.6	5	6	8	11	13	16
ICLX 50	55	6	8	10	13	17	21	26
ICLX 65	96	10	14	18	24	30	38	46
ICLX 100	175	19	25	34	43	55	69	84
ICLX 125	261	28	38	50	64	82	102	125
ICLX 150	452	48	65	87	112	141	177	216

* 2°F below min. operating temperature.

Correction factor for ΔP ($f_{\Delta P}$)

ΔP (psi)	Correction factor
0.15	2.24
0.45	1.29
0.75	1
1.25	0.77
1.75	0.65
2.25	0.58

Correction factor for liquid temperature (T_{liq})

Liquid temperature (°F)	Correction factor
-10	0.64
10	0.68
30	0.74
50	0.81
70	0.89
90	1
110	1.15
130	1.35

2-step solenoid valve, type ICLX 32-150

Nominal capacities

Dry suction line

R 404A

SI units

Capacity table for nominal conditions, Q_N [kW],
 $T_{liq} = 30\text{ }^\circ\text{C}$,
 $\Delta P = 0.05\text{ bar}$
 Superheat = 8K

Type	k_v m ³ /h	Evaporating temperature T_e							
		-50 °C	-40 °C	-30 °C	-20 °C	-10 °C	0 °C	10 °C	20 °C
ICLX 32	22	8	11	15	19	24	29	35	43
ICLX 40	29	11	15	19	25	31	38	47	56
ICLX 50	47	18	24	31	40	50	62	76	91
ICLX 65	83	32	42	56	71	89	109	133	161
ICLX 100	151	58	77	101	129	162	199	243	293
ICLX 125	225	86	115	151	192	241	297	362	436
ICLX 150	390	149	199	261	333	417	515	627	756

Correction factor for ΔP ($f_{\Delta P}$)

ΔP (bar)	Correction factor
0.01	2.24
0.03	1.29
0.05	1
0.08	0.79
0.10	0.71
0.14	0.60

Correction factor for liquid temperature (T_{liq})

Liquid temperature (°C)	Correction factor
-20	0.55
-10	0.60
0	0.66
10	0.74
20	0.85
30	1
40	1.23
50	1.68

R 404A

US units

Capacity table for nominal conditions, Q_N [Tons of Refrigeration],
 $T_{liq} = 90\text{ }^\circ\text{F}$,
 $\Delta P = 0.75\text{ psi}$
 Superheat = 12°F

Type	C_v USgal/min	Evaporating temperature T_e							
		-60 °F*	-40 °F	-20 °F	0 °F	20 °F	40 °F	60 °F	80 °F
ICLX 32	26	2.3	3.2	4.3	6	7	9	11	14
ICLX 40	34	3.1	4.2	6	7	9	12	15	18
ICLX 50	55	5	7	9	12	15	19	24	29
ICLX 65	96	9	12	16	21	27	34	42	51
ICLX 100	175	16	22	30	39	49	62	77	94
ICLX 125	261	24	33	44	58	73	92	114	139
ICLX 150	452	41	57	76	100	127	160	198	242

* 2°F below min. operating temperature.

Correction factor for ΔP ($f_{\Delta P}$)

ΔP (psi)	Correction factor
0.15	2.24
0.45	1.29
0.75	1
1.25	0.77
1.75	0.65
2.25	0.58

Correction factor for liquid temperature (T_{liq})

Liquid temperature (°F)	Correction factor
-10	0.52
10	0.57
30	0.63
50	0.72
70	0.83
90	1
110	1.29
130	1.92

2-step solenoid valve, type ICLX 32-150

ICLX 32

Ordering from the parts programme



Please note:

The ICLX function modules can only be used in housings produced in or after week 49 2012; thus the week code on the housing must be 4912 or higher.

Example (select from table I and II)

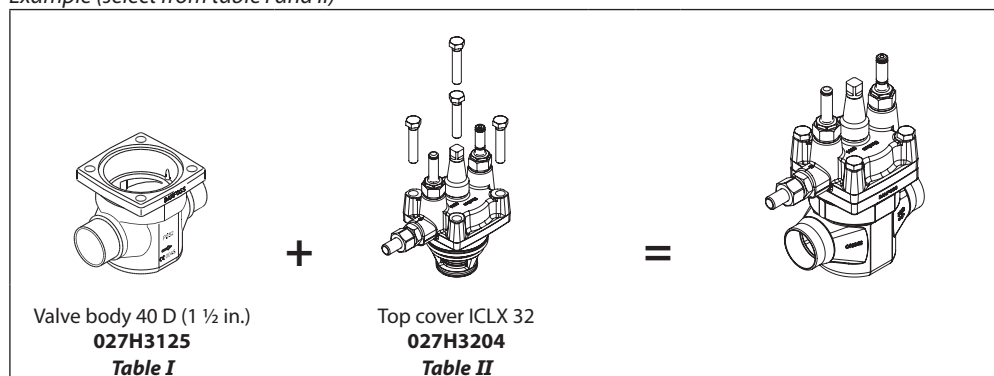

ICV 32 valve body w/different connections Table I

32 D (1 1/4 in.)	40 D (1 1/2 in.)	42 SA (1 5/8 in.)	42 SD (1 5/8 in.)
027H3120	027H3125	027H3127	027H3128
35 SD (1 3/8 in. SA)	32 A (1 1/4 in.)	32 SOC (1 1/4 in.)	40 A (1 1/2 in.)
027H3123	027H3121	027H3122	027H3126

D = Butt-weld DIN ; A = Butt-weld ANSI ;
SOC = Socket weld ANSI ; SD = Solder DIN ; SA = Solder ANSI ;

ICLX 32 Function module / top cover Table II

Description	Code Number
ICLX 32	027H3204 *

*) Including external pilot connection, NC/NO pilot valves, gasket and O-rings

Ordering complete factory assembled valve

(body, function module / top cover)

Table A

Available connections								
	32 D (1 1/4 in.)	40 D (1 1/2 in.)	42 SA (1 5/8 in.)	42 SD (1 5/8 in.)	35 SD (1 3/8 in. SA)	32 A (1 1/4 in.)	32 SOC (1 1/4 in.)	40 A (1 1/2 in.)
ICLX 32	027H3040					027H3041	027H3042	

Select from parts programme

2-step solenoid valve, type ICLX 32-150

ICLX 40

Ordering from the parts programme



Please note:

The ICLX function modules can only be used in housings produced in or after week 49 2012; thus the week code on the housing must be 4912 or higher.

Example (select from table I and II)

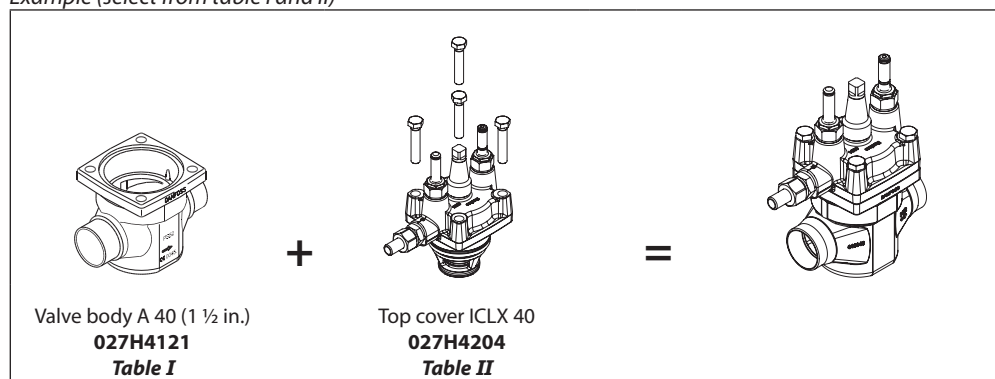

ICV 40 valve body w/different connections *Table I*

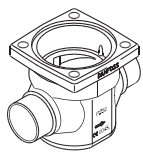

40 D (1 1/2 in.)	50 D (2 in.)	42 SA (1 5/8 in.)	42 SD (1 5/8 in.)
027H4120	027H4126	027H4124	027H4123
40 A (1 1/2 in.)	40 SOC (1 1/2 in.)	50 A (2 in.)	
027H4121	027H4122	027H4127	

ICLX 40 Function module / top cover *Table II*

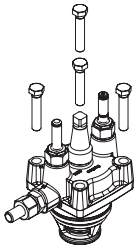

Description	Code Number
ICLX 40	027H4204 *

*) Including external pilot connection, NC / NO pilot valves, gasket and O-rings

D = Butt-weld DIN ; A = Butt-weld ANSI ;
SOC = Socket weld ANSI ; SD = Solder DIN ; SA = Solder ANSI ;

Ordering complete factory assembled valve

(body, function module/top cover)

Table A

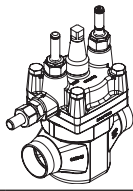

	Available connections						
	40 D (1 1/2 in.)	50 D (2 in.)	42 SA (1 5/8 in.)	42 SD (1 5/8 in.)	40 A (1 1/2 in.)	40 SOC (1 1/2 in.)	50 A (2 in.)
ICLX 40	027H4040				027H4041	027H4042	

Select from parts programme

2-step solenoid valve, type ICLX 32-150

ICLX 50

Ordering from the parts programme



Please note:

The ICLX function modules can only be used in housings produced in or after week 49 2012; thus the week code on the housing must be 4912 or higher.

Example (select from table I and II)

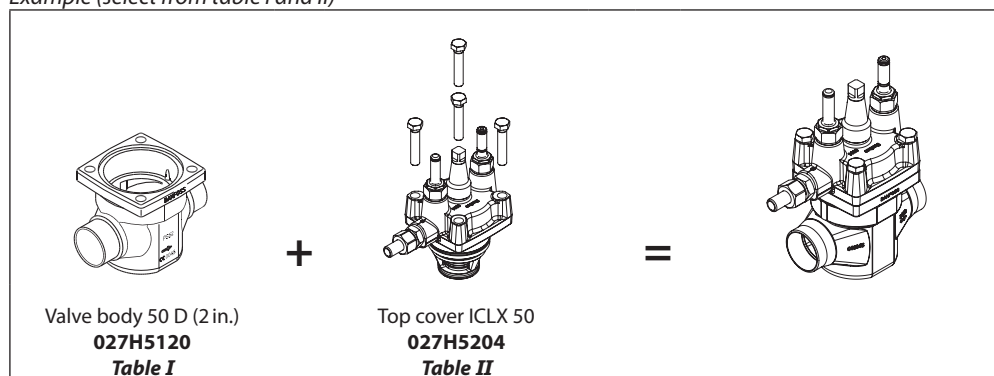

ICV 50 valve body w/different connections Table I

50 D (2 in.)	65 D (2 ½ in.)	54 SD (2 1/8 in. SA)	50 A (2 in.)
027H5120	027H5124	027H5123	027H5121
50 SOC (2 in.)	65 A (2 ½ in.)		
027H5122	027H5125		

D = Butt-weld DIN ; A = Butt-weld ANSI ;
SOC = Socket weld ANSI ; SD = Solder DIN ; SA = Solder ANSI ;

ICLX 50 Function module / top cover Table II

Description	Code Number
ICLX 50	027H5204 *

*) Including external pilot connection, NC/NO pilot valves, gasket and O-rings

Ordering complete factory assembled valve (body, function module/top cover)

Table A

Available connections						
	50 D (2 in.)	65 D (2 ½ in.)	54 SD (2 1/8 in. SA)	50 A (2 in.)	50 SOC (2 in.)	65 A (2 ½ in.)
ICLX 50	027H5040			027H5041	027H5042	

Select from parts programme

ICLX 65

Ordering from the parts programme



Please note:

The ICLX function modules can only be used in housings produced in or after week 49 2012; thus the week code on the housing must be 4912 or higher.

Example (select from table I and II)

ICV 65 valve body w/different connections Table I

ICLX 65 Function module / top cover Table II

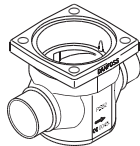

65 D (2 1/2 in.)	65 A (2 1/2 in.)	80 D (3 in.)	80 A (3 in.)
027H6120	027H6121	027H6126	027H6127
67 SA (2 5/8 in.)	76 SD (3 in.)	65 SOC (2 1/2 in.)	
027H6125	027H6124	027H6123	

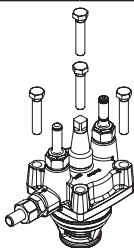

Description	Code Number
ICLX 65	027H6204 *

*) Including external pilot connection, NC/NO pilot valves, gasket and O-rings

D = Butt-weld DIN ; A = Butt-weld ANSI ; SOC = Socket weld ANSI ; SD = Solder DIN ; SA = Solder ANSI ;

Ordering complete factory assembled valve (body, function module / top cover)

Table A

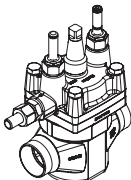

ICLX 65	Available connections						
	65 D (2 1/2 in.)	65 A (2 1/2 in.)	80 D (3 in.)	80 A (3 in.)	67 SA (2 5/8 in.)	76 SD (3 in.)	65 SOC (2 1/2 in.)
	027H6040	027H6041	027H8040	027H8042			027H6042

Select from parts programme

2-step solenoid valve, type ICLX 32-150

Complete factory assembled valve

(body, function module / topcover and NC / NO pilot valves)

ICLX 100

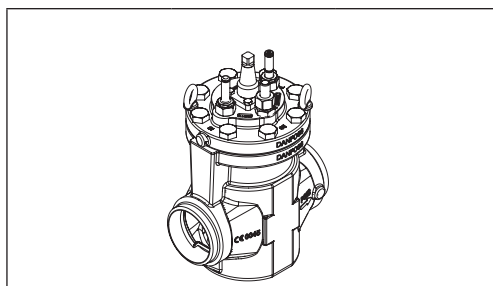

ICLX 100	Available connections	
	100 D (4 in.)	100 A (4 in.)
	027H7147	027H7148

ICLX 125

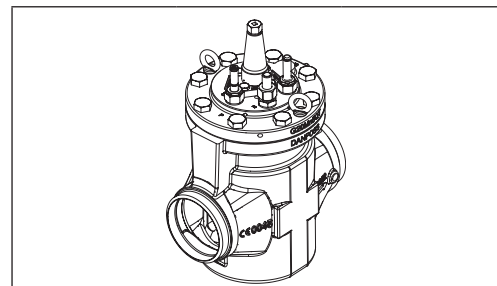

ICLX 125	Available connections	
	125 D (5 in.)	125 A (5 in.)
	027H7157	027H7158

ICLX 150

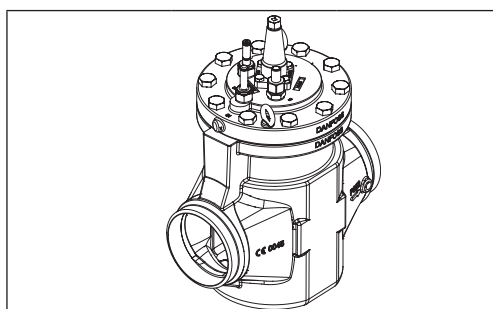

ICLX 150	Available connections	
	150 D (6 in.)	150 A (6 in.)
	027H7167	027H7168

Accessories

ICV PM flanged valve housings

ICV PM flanged valve housings can replace the PM valves on already installed refrigeration systems.

Pressure range

The ICV PM valve housing is designed for a max. working pressure of 28 bar g / 406 psig and therefore a suitable replacement for PM valves in the service market. They also offer the same drop-in dimensions as the PM valves.

Description	Code no.
ICV 25 PM Valve housing	027H2119 *
ICV 32 PM Valve housing	027H3129 *
ICV 40 PM Valve housing	027H4128 *
ICV 50 PM Valve housing	027H5127 **
ICV 65 PM Valve housing	027H6128 **

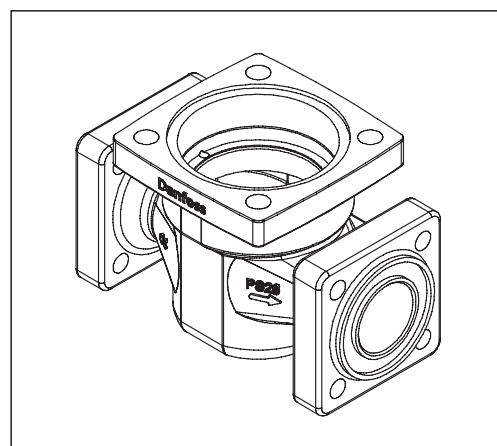

*) Includes ICV PM valve housing, flange gaskets and flange bolts.

**) Includes ICV PM valve housing, flange gaskets, flange bolts and flange nuts.

Function modules and top covers must be ordered separately (see the section "Ordering").

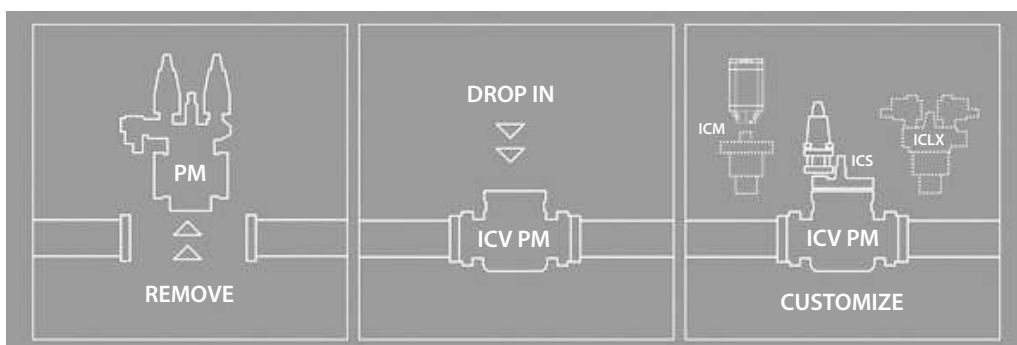

2-step solenoid valve, type ICLX 32-150

Accessories

ICV (H)A4A flanged valve housings

ICV (H)A4A flanged valve housings can replace the (H)A4A valves on already installed refrigeration systems.

Pressure range

The ICV (H)A4A valve housing is designed for a max. working pressure of 28 bar g / 406 psig and therefore a suitable replacement for (H)A4A valves in the service market. They also offer the same drop-in dimensions as the (H)A4A valves.

Description	Code no.
ICV 25 (H)A4A Valve housing	027H2304 *
ICV 32 A4A Valve housing	027H3130 *
ICV 32 HA4A Valve housing	027H3131 *
ICV 40 (H)A4A Valve housing	027H4129 *
ICV 50 (H)A4A Valve housing	027H5128 **)
ICV 65 (H)A4A Valve housing	027H6129 **)

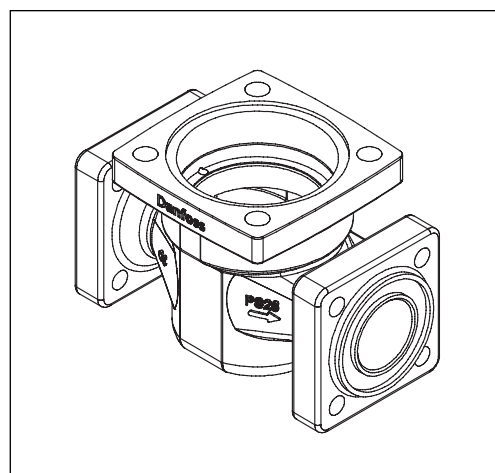

*) Includes ICV (H)A4A valve housing, flange gaskets and flange bolts.

***) Includes ICV (H)A4A valve housing, flange gaskets, flange bolts and flange nuts.

Function modules and top covers must be ordered separately (see the section "Ordering").

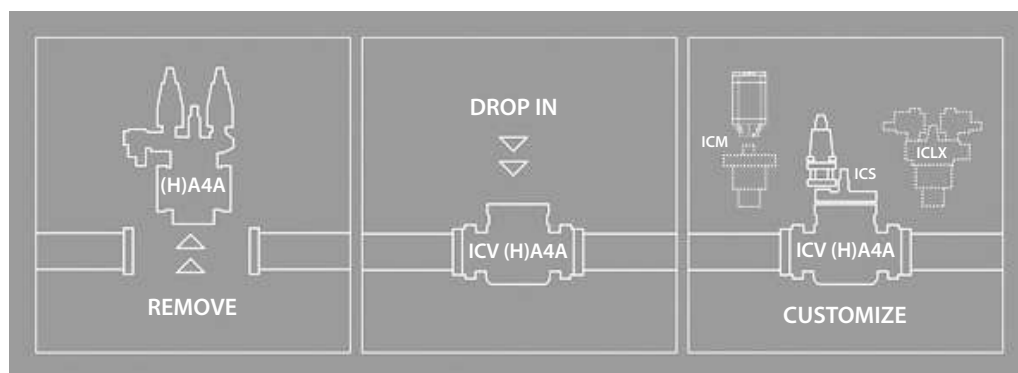

2-step solenoid valve, type ICLX 32-150

Accessories

Cap including gasket

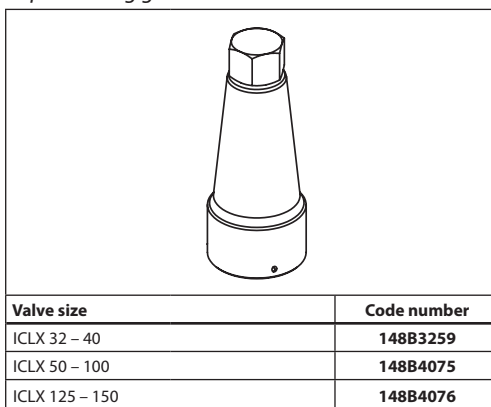

External pilot connection



ICLX	Description	Code no.
32 – 80	External pilot connection (incl. damping orifice, D: 1.0 mm)	027F1048
32 – 80	External pilot connection (1/4" FPT) (incl. damping orifice, D: 1.0 mm)	027B2065
100 – 150	External pilot connection (incl. damping orifice, D: 1.8 mm)	027F1049
100 – 150	External pilot connection (1/4" FPT) (incl. damping orifice, D: 1.8 mm)	027B2066
32 – 150	Accessory bag with seal and O-ring for pilot valve	027F0666

ICLX	Description	Code no.
32 – 80	Damping orifice for EVM. 10 pcs, (D: 1.0 mm)	027F0664
100 – 150	Damping orifice for EVM. 10 pcs, (D: 1.8 mm)	027F0176

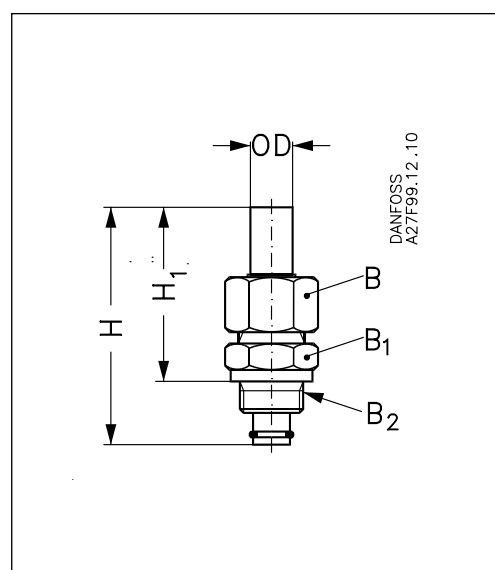

A damping orifice should be installed if the pressure difference between the low and the high pressure side is more than 6 bar.

Accessories			H	H ₁	OD	B	B ₁	B ₂
-------------	--	--	---	----------------	----	---	----------------	----------------

External pilot connection

	mm		90	66	18	NV 32	NV 32	M 24 × 1.5
	in.		3.54	2.60	0.71			

2-step solenoid valve, type ICLX 32-150

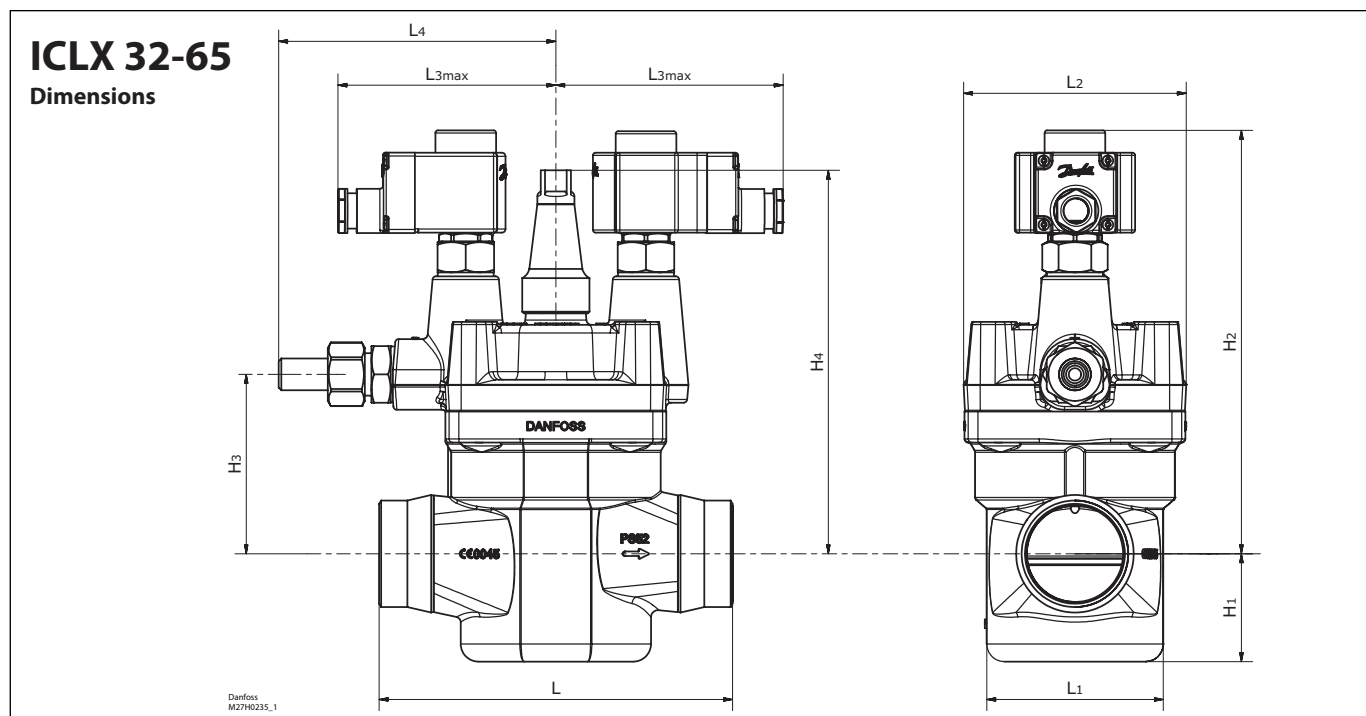

ICLX 32	L							
	32 D	40 D	32 A	40 A	32 SOC	35 SD	42 SD	42 SA
mm	145	145	145	145	148	148	148	148
in.	5.7	5.7	5.7	5.7	5.8	5.8	5.8	5.8

ICLX 32	L ₁	L ₂	L _{3max}		L ₄	H ₁	H ₂	H ₃	H ₄	Net weight
			10W	20W						
mm	75	104	125	135	159	43	193	82	168	9.9 kg
in.	3.0	4.1	4.9	5.3	6.3	1.7	7.6	3.2	6.6	21.8 lb

ICLX 40	L						
	40 D	50 D	40 A	50 A	40 SOC	42 SD	42 SA
mm	160	180	160	180	180	180	180
in.	6.3	7.1	6.3	7.1	7.1	7.1	7.1

ICLX 40	L ₁	L ₂	L _{3max}		L ₄	H ₁	H ₂	H ₃	H ₄	Net weight
			10W	20W						
mm	86	109	125	135	157	52	217	87	174	11.7 kg
in.	3.4	4.3	4.9	5.3	6.2	2.0	8.5	3.4	6.9	25.8 lb

ICLX 50	L					
	50 D	65 D	50 A	65 A	50 SOC	54 SD
mm	200	210	200	210	216	216
in.	7.9	8.3	7.9	8.3	8.5	8.5

ICLX 50	L ₁	L ₂	L _{3max}		L ₄	H ₁	H ₂	H ₃	H ₄	Net weight
			10W	20W						
mm	100	126	125	135	157	61	240	102	217	15.3 kg
in.	3.9	5.0	4.9	5.3	6.2	2.4	9.4	4.0	8.5	33.7 lb

ICLX 65	L						
	65 D	80 D	65 A	80 A	65 SOC	76 SD	67 SA
mm	230	245	230	245	230	245	245
in.	9.1	9.6	9.1	9.6	9.1	9.6	9.6

ICLX 65	L ₁	L ₂	L _{3max}		L ₄	H ₁	H ₂	H ₃	H ₄	Net weight
			10W	20W						
mm	130	141	125	135	163	69	257	123	234	20.3 kg
in.	5.1	5.6	4.9	5.3	6.4	2.7	10.1	4.8	9.2	44.7 lb

D = Butt-weld DIN ; A = Butt-weld ANSI ; SOC = Socket weld ANSI ; SD = Solder DIN ; SA = Solder ANSI

ICLX 100-150

Dimensions

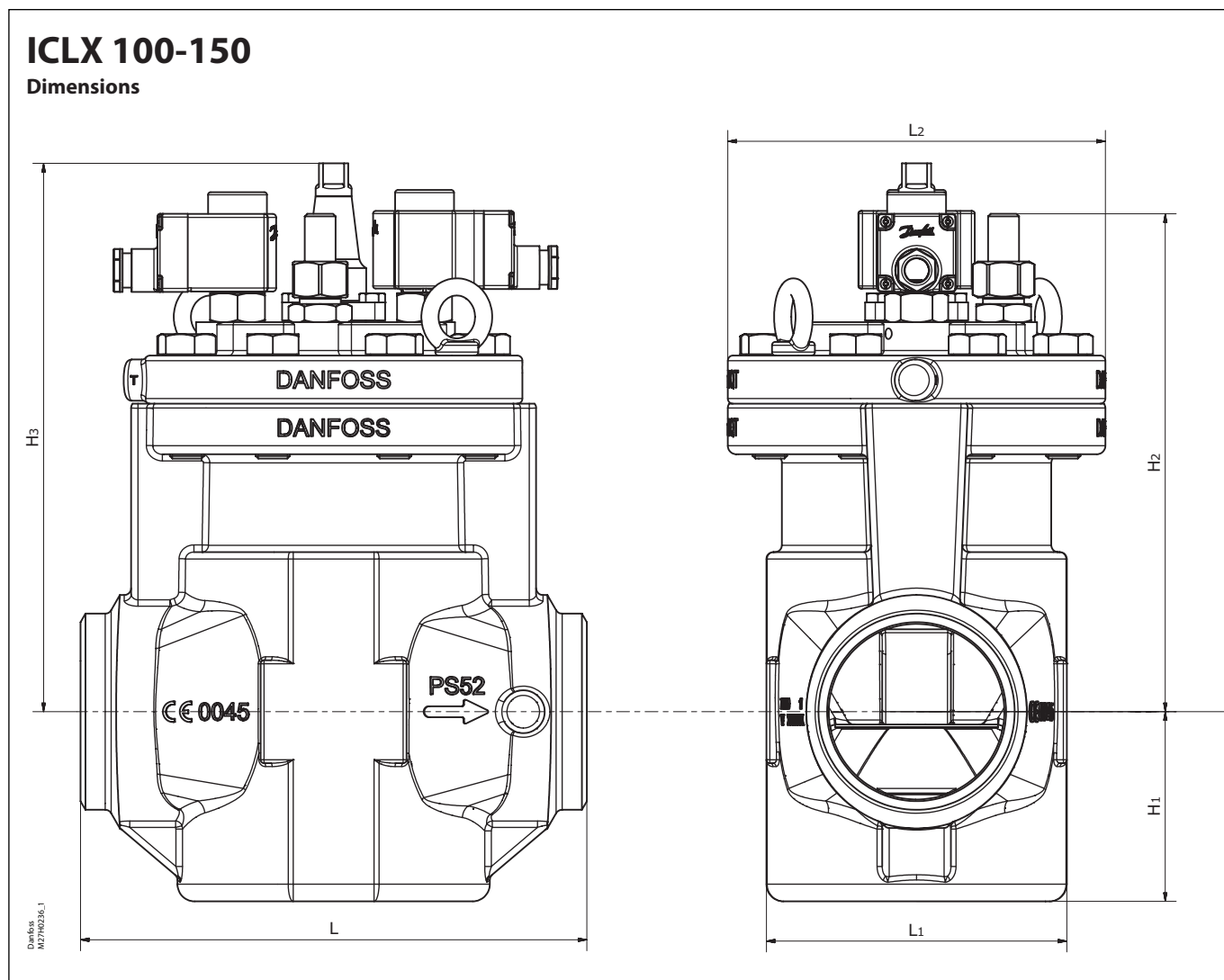

Type		L	L ₁	L ₂	H ₁	H ₂	H ₃	Net weight
ICLX 100	mm	295	175	220	111	297	320	53.2 kg
	in.	11.6	6.9	8.7	4.4	11.7	12.6	117.3 lb
ICLX 125	mm	350	215	260	142	305	376	80.8 kg
	in.	13.8	8.5	10.2	5.6	12	14.8	178.1 lb
ICLX 150	mm	445	255	300	170	357	426	132.5 kg
	in.	17.5	10.0	11.8	6.7	14.1	16.8	292.1 lb

2-step solenoid valve, type ICLX 32-150

Connections

D: Butt-weld (EN 10220)

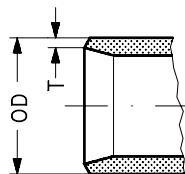

Size mm	Size in.	OD mm	T mm	OD in.	T in.		
32	(1 ¼)	42.4	2.6	1.669	0.102		
40	(1 ½)	48.3	2.6	1.902	0.103		
50	(2)	60.3	2.9	2.37	0.11		
65	(2 ½)	76.1	2.9	3	0.11		
80	(3)	88.9	3.2	3.50	0.13		
100	(4)	114.3	3.6	4.5	0.14		
125	(5)	140.7	4	5.5	0.16		
150	(6)	168.3	6.3	6.6	0.25		

A: Butt-weld ANSI (B 36.10)

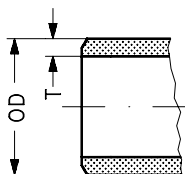

Size mm	Size in.	OD mm	T mm	OD in.	T in.	Schedule	
(32)	1 ¼	42.4	4.9	1.669	0.193	80	
(40)	1 ½	48.3	5.1	1.902	0.201	80	
(50)	2	60.3	3.9	2.37	0.15	40	
(65)	2 ½	73.0	5.2	2.87	0.20	40	
(80)	3	88.9	5.5	3.50	0.22	40	
(100)	4	114.3	6	4.5	0.24		
(125)	5	140.7	6.5	5.5	0.26		
(150)	6	168.3	7.1	6.6	0.28		

SOC:
Socket welding ANSI (B 16.11)

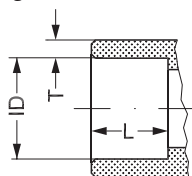

Size mm	Size in.	ID mm	T mm	ID in.	T in.	L mm	L in.
(32)	1 ¼	42.7	6.1	1.743	0.240	13	0.51
(40)	1 ½	48.8	6.6	1.921	0.260	13	0.51
(50)	2	61.2	6.2	2.41	0.24	16	0.63
(65)	2 ½	74	8.8	2.91	0.344	16	0.63

SD: Soldering (EN 1254-1)

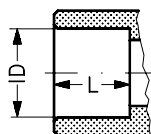

Size mm	Size in.	ID mm		ID in.		L mm	L in.
35		35.07				25	
42		42.07				28	
54		54.09				33	
76		76.1				33	

SA: Soldering (ANSI B 16.22)

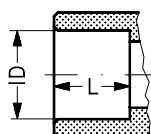

	Size in.			ID in.			L in.
	1 3/8			1.375			0.984
	1 5/8			1.625			1.102
	2 1/8			2.125			1.300
	2 ½			2.625			1.300

Dual position solenoid valve

Type ICSH 25-80

Contents

	Page
Features	33
The ICSH Concept	34
Design (valve)	34
Technical data	34
Approvals	34
Function	35
Controller and Wiring	36
Material specification	37
Nominal capacities	38
Ordering	44
Accessories	49
Dimensions	51
Connections	53

Dual position solenoid valve

Type ICSH 25-80



ICSH dual position solenoid valve belongs to the ICV family and consists of an ICV housing, an ICS insert together with an ICSH top cover with 2 EVM normally closed solenoid pilots installed in the top cover.

ICSH is used in hot gas lines for the opening of hot gas defrost flow to the evaporator in 2 steps. Both steps are activated by a controller or a PLC energizing the magnetic coils in a time delay sequence.

Step 1 (approx. 20% of full flow) is to allow a smooth pressure build-up in the evaporator, while the subsequent step 2 opens the flow to 100% to get the full defrost capacity.

The ICSH is designed for large industrial refrigeration systems with ammonia, fluorinated refrigerants or CO₂.

The ICSH features 2 configuration options, which is established at site.

One option is dependent configuration, which secures that step 2 can never open unless step 1 has been mechanically activated.

Second option is independent configuration that allows step 2 to open disregarding step 1. By choosing the independent option attention should be paid to the risk of liquid hammering in case the step 1 for any reason is disregarded.

Features

- Designed for Industrial Refrigeration applications for a maximum working pressure of 52 bar g / 754 psig.
- Applicable to HCFC, HFC, R717 (Ammonia) and R744 (CO₂).
- Direct welded connections.
- Connection types include butt weld, socket weld and solder connections.
- Low temperature steel body.
- Low weight and compact design.
- 2-wire connection for use with a timer relay or 4 wire connection for connecting to a controller or a PLC.
- The ICSH main valve top cover can be oriented in any direction without the function of pilot valves being affected.
- Stabilizes working conditions and eliminates pressure pulsations during opening of hot gas.
- Manual opening possible.
- PTFE seat provides excellent valve tightness.
- Service friendly design.

Dual position solenoid valve, type ICSH 25-80

Approvals

The ICSH valve concept has been designed to fulfill global refrigeration requirements.



ICSH valves		
Nominal bore	DN ≤ 25 (1 in.)	DN 32 - 80 (1¼ - 3 in.)
Classified for	Fluid group I	
Category	Article 4, paragraph 3	II

The ICSH Concept

The ICSH concept is developed to highest flexibility of direct welded connections. For valve sizes ICSH 25 – ICSH 65 a wide range of connection sizes and types is available.

The direct welded (non-flanged) connections secure low risk of leakage.

- There are five valve bodies available (ICSH 80 makes use of ICSH 65 housing).

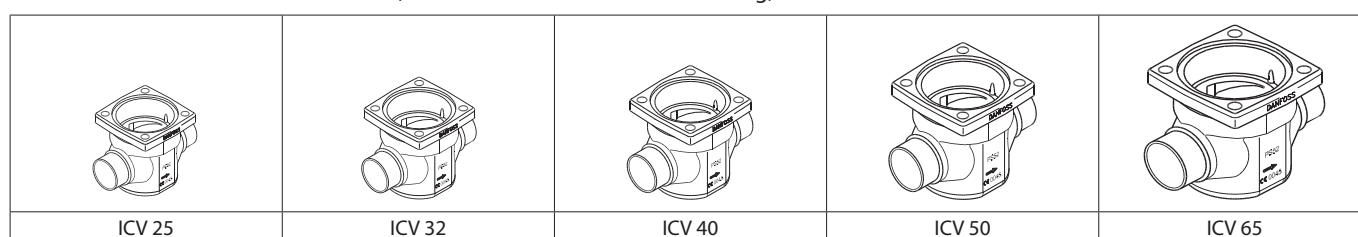

D	A	SOC	SD	SA
Butt-weld DIN	Butt-weld ANSI	Socket weld ANSI	Solder DIN	Solder ANSI

Design (valve)

Connections

There is a wide range of connection types available with ICSH valves:

- D: Butt weld, EN 10220
- A: Butt weld, ANSI (B 36.10)
- SOC: Socket weld, ANSI (B 16.11)
- SD: Solder connection, EN 1254-1
- SA: Solder connection, ANSI (B 16.22)

The ICSH valves are approved in accordance with the European standard specified in the Pressure Equipment Directive and are CE marked. For further details / restrictions - see Installation Instruction.

Valve body and top cover material
Low temperature steel

Technical data

- **Refrigerants**
Applicable to HCFC, HFC, R717 (Ammonia) and R744 (CO₂).
- **Temperature range:**
Media: -60 – 120 °C / -76 – 248 °F.
- **Pressure**
The valve is designed for a max. working pressure of 52 bar g / 754 psi g
- Step 1 20% capacity of step 2 (full capacity)

- **Surface protection**
The ICSH external surface is zinc-chromated to provide good corrosion protection.
- **Min. opening pressure differential:**
0.2 bar (2.9 psi) higher inlet pressure than outlet pressure for fully open.
- **Coil requirements:**
Both coils to be IP67.

	ICSH 25-25	ICSH 32	ICSH 40	ICSH 50	ICSH 65	ICSH 80
K _v (m ³ /h) (full capacity)	11.5	17	27	44	70	85
C _v (USgal/min) (full capacity)	13.3	20	31	51	81	98

Dual position solenoid valve, type ICSH 25-80

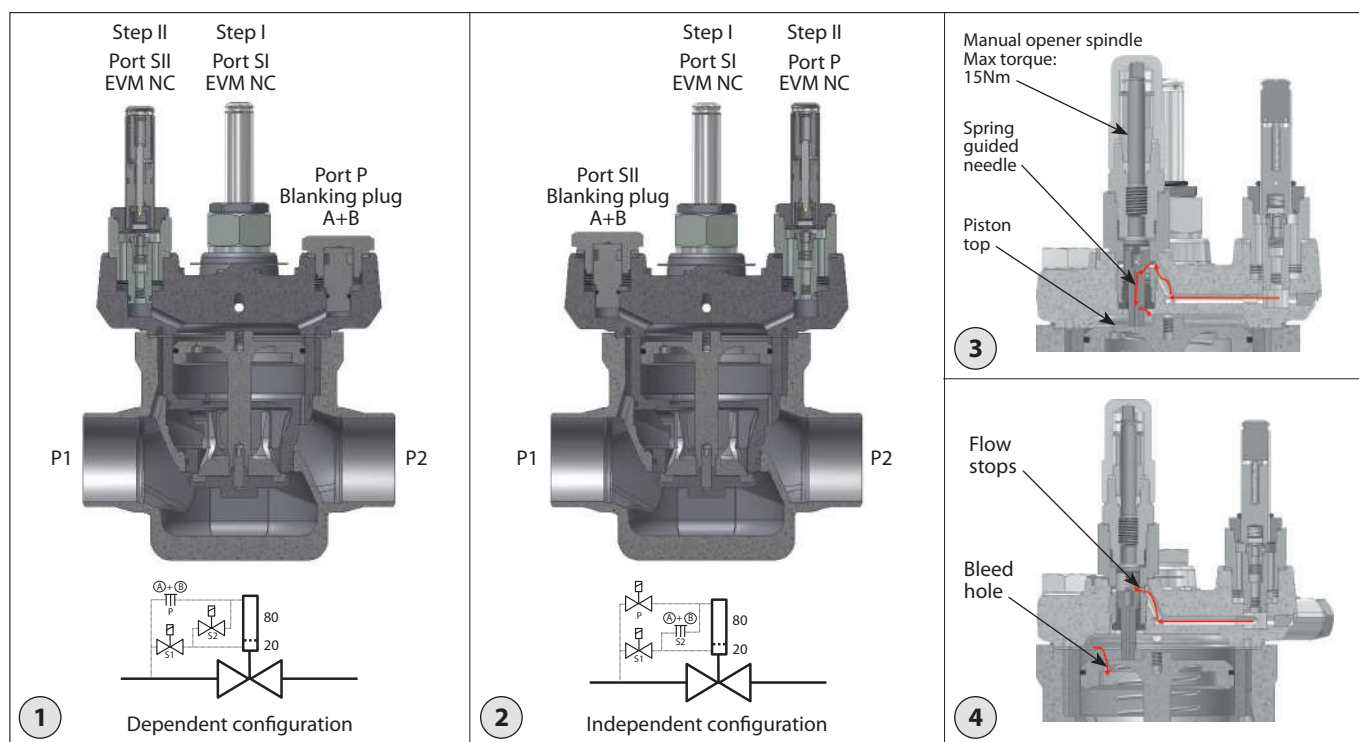

Function

The ICSH is designed for a 2 step opening of the hot gas flow for the evaporator defrost. Step 1 (20% capacity) is intended for a smooth pressure build up in the evaporator - step 2 will open for full capacity.

The valve is pilot controlled by 2 standard EVM Normally Closed valves and the 2 EVM's are controlled by an external controller like PLC.

The external controller simply needs to activate the 2 EVM coils in a sequence with a certain time offset. The time offset depends on the specific conditions around the ICSH and must be determined at site.

The opening of the ICSH is done by a pressure difference between the inlet pressure P1 and the outlet pressure P2, and for the main valve to open fully, a Δp of 0.2 bar (2.9 psi) is needed.

The ICSH main valve can be configured into 2 different configurations: Dependent or Independent.

The Dependent setup (fig. 1) means that fully open (step 2) can only be performed if step 1 is performed successfully. If step 1 for some reason fails, the valve will not open at all.

The matching control program should, in this case, be to activate step 1 coil followed by activation of step 2 coil.

Dependent setup is done by installing the 2 EVM's in Port SI (step 1) and Port SII (step 2), and blanking off the P port with Blanking plug A+B.

The Independent setup (fig. 2) involves the option to force step 2 to open independent of the result of step 1.

The matching control program should also in this case be to activate step 1 coil followed by activation of step 2 coil. When step 2 is activated the full flow will immediately be started.

Attention:

A risk of liquid hammering in the system might be present.

Independent setup is done by installing the 2 EVM's in Port SI (step 1) and Port P (step 2), and blanking off the SII port with Blanking plug A+B.

The internal channel structure allows in both configurations a direct flow to the step 1 EVM. By activating step 1 the flow will continue through the spring guided needle that is resting on the top of the piston (see fig. 3).

The flow will build up a pressure on top of the piston, which will start moving down i.e. start open the main valve. The spring guided needle follows the pistons movement downwards and after a predefined distance the needle reaches its stop position, where the needle closes the supply flow (see fig 4).

The bleed hole in the piston top will allow a certain flow out of the pressurized chamber thus enable the piston to move upwards, but any movement of the piston is now being controlled by the needle that compensates by opening the supply flow.

The needle will balance the supply/bleed flows and keep the piston at this position. Step I flow - equivalent to approx. 20% of capacity - has now been established.

After a predetermined period of time the step II coil is activated.

In dependent set-up further flow can only reach the step II EVM if step I EVM is open (working properly). In independent set-up further flow can reach the step II EVM regardless the status of step I. Once flow is passing through step II EVM it continues to the top of the piston and moves the piston to full open position.

For both configurations the valve will close and stay closed when both coils are de-energised.

The closing is achieved by drainage through the bleed hole.

ICSH is including a manual opener like all the valves in the ICV family. The operation of the opener is done by turning the spindle clockwise (opening the valve) or counterclockwise (closing the valve).



Attention should be paid to the maximum torque applied to the spindle when turning: **Never exceed 15 Nm to the spindle in any direction.**

Dual position solenoid valve, type ICSH 25-80

Controller and Wiring

The 2 steps need to be activated from a PLC in a time delay sequence. The time delay itself must be determined on site since local conditions are decisive.

The wiring from the controller to the 2 coils can be done by either one or two cables.

By one cable layout only one signal is needed though an additional timer relay has to be connected according to the figure to the right.

Two cable layout requires two subsequent output signals from the PLC.

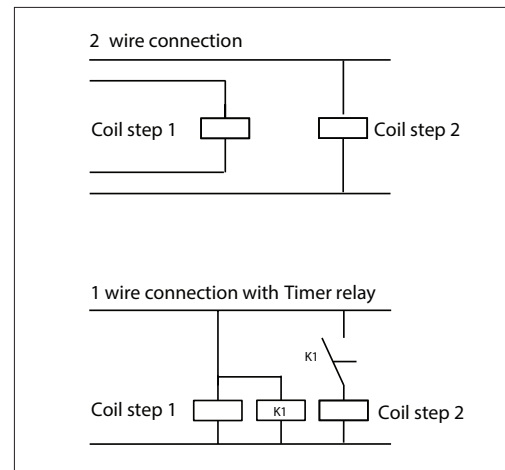

Dual position solenoid valve, type ICSH 25-80

Material specification

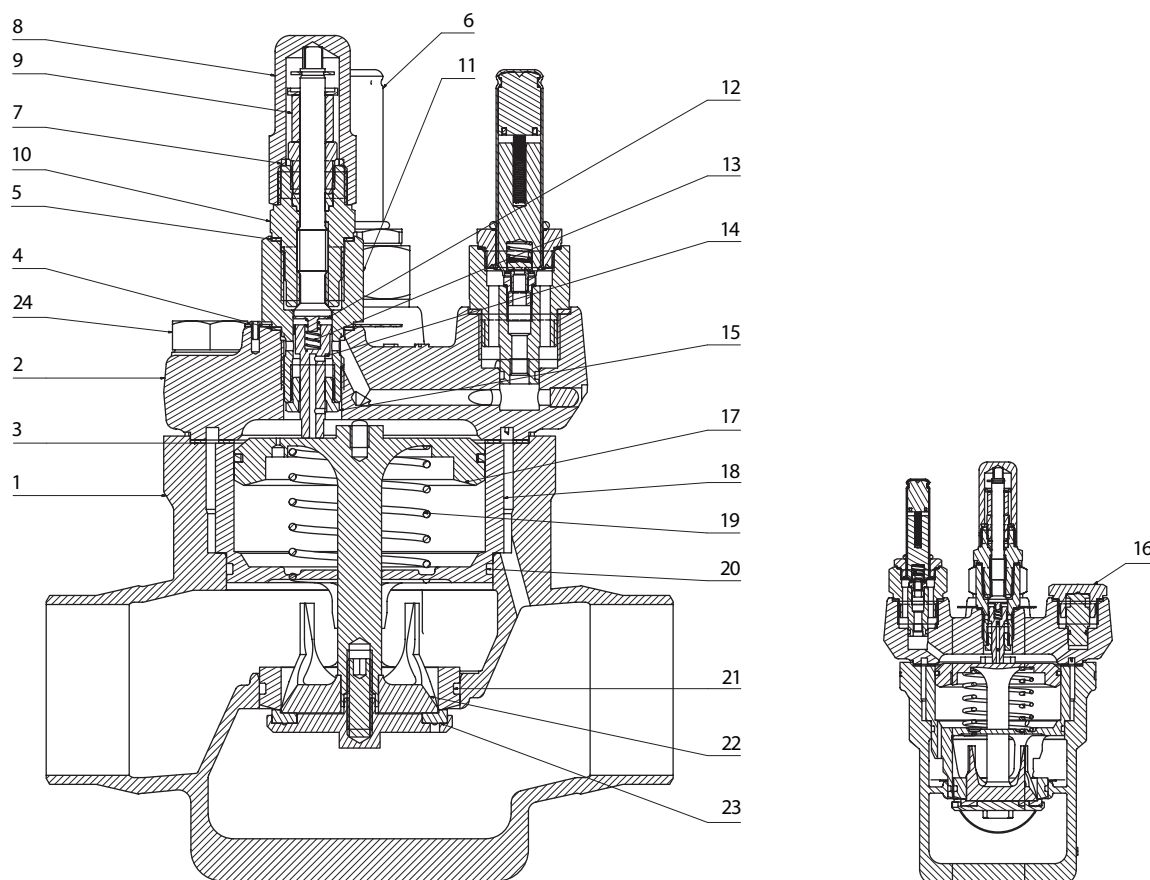

No	Part	Material	EN	ASTM
1	Body	Low temperature Steel	G20Mn5QT EN 10213-3	LCC A352
2	Top Cover	Low temperature Steel	P285QH EN-10222-4	LF2 A350
3	Gasket	Fibre non asbestos		
4	Gasket	Aluminium		
5	Gasket	Aluminium		
6	EVM NC			
7	Gasket	Nylon		
8	Cap	Steel		
9	Stopper	Nylon		
10	Manual opener	Steel		
11	Needle Housing	Stainless steel		
12	Spring Bush	Stainless steel		
13	Spring	Steel		
14	Needle	Stainless steel		
15	Nozzle	Cast iron		
16	Plug	Steel		
17	Piston	Steel		
18	Cylinder	Steel		
19	Spring	Steel		
20	O-ring	Cloroprene(Neoprene)		
21	O-ring	Cloroprene(Neoprene)		
22	Cone	Steel		
23	Valve Plate	PTFE		
24	Bolt	Stainless steel	A2-70 EN1515-1	A2-70, B1054

Dual position solenoid valve, type ICSH 25-80

Nominal capacities

Hotgas line

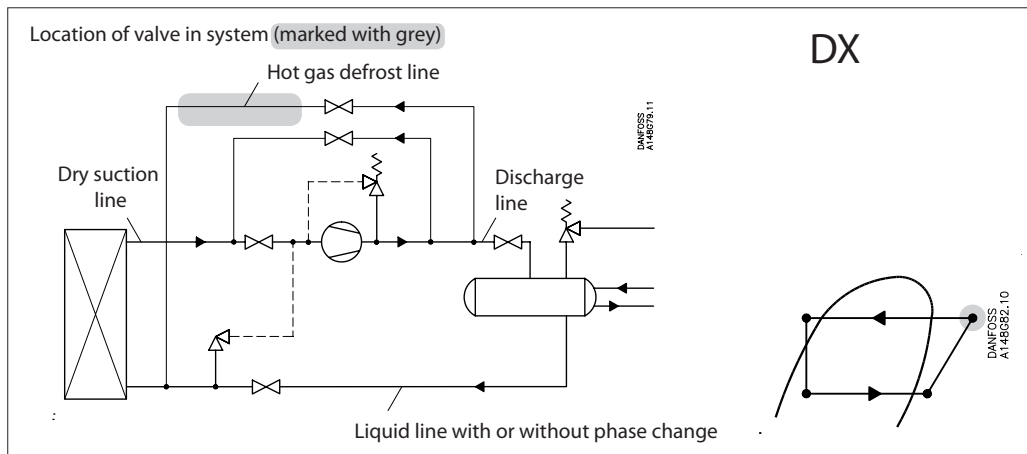
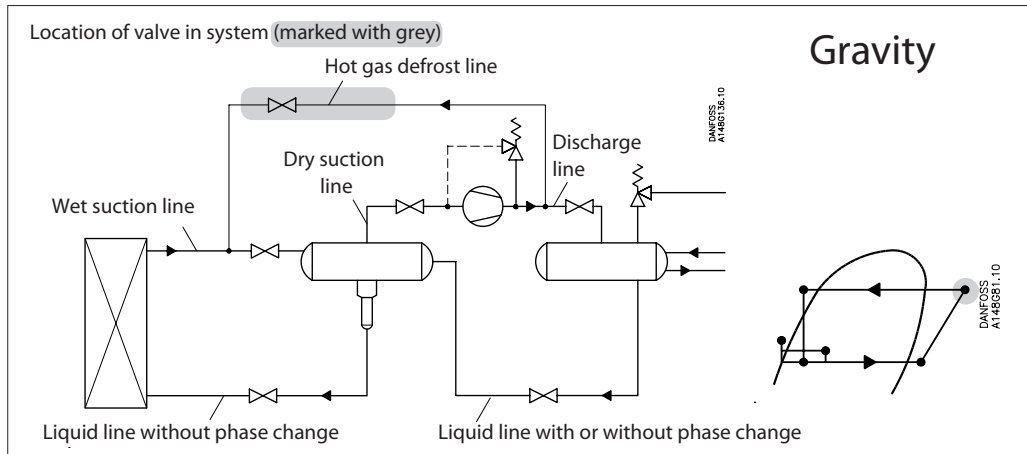
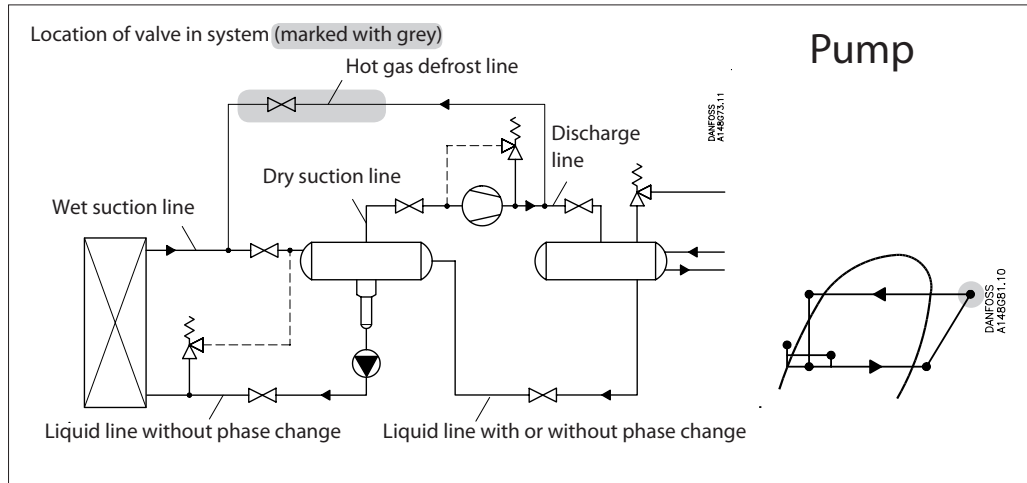

Nominal capacities
Hotgas line
SI units

Calculation example (R 717 capacities):

An application has following running conditions:

$$\begin{aligned} T_e &= -20\text{ }^\circ\text{C} \\ Q_o &= 90\text{ kW} \\ T_{liq} &= 10\text{ }^\circ\text{C} \\ \text{Max. } \Delta p &= 0.4\text{ bar} \\ T_{disch.} &= 60\text{ }^\circ\text{C} \end{aligned}$$

The capacity table is based on nominal condition ($\Delta p = 0.2\text{ bar}$, $T_{liq} = 30\text{ }^\circ\text{C}$, $P_{disch.} = 12\text{ bar}$, $T_{disch.} = 80\text{ }^\circ\text{C}$)

Therefore the actual capacity must be corrected to nominal condition by means of correction factors.

Correction factor for Δp 0.4 bar $f_{\Delta p} = 0.71$
 Correction factor for liquid temperature $f_{T_{liq}} = 0.92$
 Correction factor for $T_{disch.}$ 60°C, $f_{T_{disch.}} = 0.97$

$$\begin{aligned} Q_n &= Q_o \times f_{\Delta p} \times f_{T_{liq}} \times f_{T_{disch.}} = \\ 90 \times 0.71 \times 0.92 \times 0.97 &= 57\text{ kW} \end{aligned}$$

From the capacity table an ICS 25-15 function module with Q_n capacity 73 kW is selected.

US units

Calculation example (R 717 capacities):

An application has following running conditions:

$$\begin{aligned} T_e &= 0\text{ }^\circ\text{F} \\ Q_o &= 18\text{ TR} \\ T_{liq} &= 50\text{ }^\circ\text{F} \\ \text{Max. } \Delta p &= 5.8\text{ psi} \\ T_{disch.} &= 120\text{ }^\circ\text{F} \end{aligned}$$

The capacity table is based on nominal conditions ($\Delta p = 3\text{ psi}$, $T_{liq} = 90\text{ }^\circ\text{F}$, $P_{disch.} = 185\text{ psi}$, $T_{disch.} = 180\text{ }^\circ\text{F}$)

Therefore the actual capacity must be corrected to nominal condition by means of correction factors.

Correction factor for Δp 5.8 psi, $f_{\Delta p} = 0.72$
 Correction factor for liquid temperature $f_{T_{liq}} = 0.92$
 Correction factor for $T_{disch.}$ 120°C, $f_{T_{disch.}} = 0.95$

$$\begin{aligned} Q_n &= Q_o \times f_{\Delta p} \times f_{T_{liq}} \times f_{T_{disch.}} = \\ 18 \times 0.72 \times 0.92 \times 0.95 &= 11.3\text{ TR} \end{aligned}$$

From the capacity table an ICS 25-10 function module with Q_n capacity 12.0 TR is selected.

Dual position solenoid valve, type ICSH 25-80

Nominal capacities

Hotgas line

SI units

Capacity table for nominal conditions, Q_N [kW],
 $T_{liq} = 30^\circ\text{C}$,
 $P_{disch.} = 12 \text{ bar}$,
 $\Delta P = 0.2 \text{ bar}$,
 $T_{disch.} = 80^\circ\text{C}$
 Superheat = 8°C

R 717

Function module	Valve body size	K_v [m ³ /h]	Evaporating temperature [°C]							
			-50	-40	-30	-20	-10	0	10	20
ICS25-5	25	1.7	19.8	20.2	20.5	20.7	20.9	21.1	21.3	21.5
ICS25-10		3.5	40.8	41.5	42.0	42.5	43.0	43.5	44.0	44.2
ICS25-15		6	70.0	71.0	72.0	73.0	74.0	74.8	75.4	76.0
ICS25-20		8	93.0	95.0	96.0	97.5	99.0	99.7	101	101
ICS25-25		11.5	134	136	138	140	142	143	144	145
ICS32	32	17	199	201	205	207	209	211	213	215
ICS40	40	27	315	320	325	329	333	336	339	341
ICS50	50	44	514	521	529	536	542	548	553	556
ICS65	65	70	817	829	843	854	864	872	879	885
ICS80	80	85	991	1007	1022	1035	1048	1058	1067	1074

Correction factor for ΔP ($f_{\Delta P}$)

ΔP [bar]	Correction factor
0.2	1.00
0.25	0.89
0.3	0.82
0.4	0.71
0.5	0.63
0.6	0.58

Correction factor for discharge temperature ($T_{disch.}$)

Discharge temperature	Correction factor
50°C	0.96
60°C	0.97
80°C	1.00
90°C	1.01
100°C	1.03
110°C	1.04
120°C	1.06

Correction factor for liquid temperature (T_{liq})

Liquid temperature	Correction factor
-20°C	0.82
-10°C	0.86
0°C	0.88
10°C	0.92
20°C	0.96
30°C	1.00
40°C	1.04
50°C	1.09

R 717

US units

Capacity table for nominal conditions, Q_N [Tons of Refrigeration],
 $T_{liq} = 90^\circ\text{F}$,
 $\Delta P = 2.9 \text{ psi}$,
 $P_{disch.} = 185 \text{ psi}$,
 $T_{disch.} = 180^\circ\text{F}$
 Superheat = 12°F

Function module	Valve body size	C_v [USgal/min]	Evaporating temperature [°F]							
			-60°F	-40°F	-20°F	0°F	20°F	40°F	60°F	80°F
ICS25-5	25	2	5.6	5.7	5.8	5.8	5.9	6.0	6.0	6.0
ICS25-10		4.1	11.4	11.6	11.8	12.0	12.1	12.3	12.3	12.4
ICS25-15		7	19.6	20.0	20.3	20.6	20.8	21.0	21.2	21.3
ICS25-20		9.3	26.2	26.6	27.0	27.4	27.8	28.0	28.2	28.3
ICS25-25		13.3	37.6	38.3	39.0	39.4	39.9	40.3	40.5	40.8
ICS32	32	20	55.5	56.5	57.5	58.3	59.0	59.5	60.0	60.3
ICS40	40	31	88.0	90.0	91.0	92.5	94.0	94.5	95.0	95.7
ICS50	50	51	144	146	149	151	153	154	155	156
ICS65	65	81	229	233	237	240	243	245	247	248
ICS80	80	98	275	280	285	289	292	295	297	298

Correction factor for ΔP ($f_{\Delta P}$)

ΔP [psi]	Correction factor
3	1.00
4	0.87
5	0.79
6	0.72
7	0.66
8	0.62

Correction factor for discharge temperature ($T_{disch.}$)

Discharge temperature	Correction factor
120°F	0.95
140°F	0.97
180°F	1.00
200°F	1.02
210°F	1.02
230°F	1.04
250°F	1.06

Correction factor for liquid temperature (T_{liq})

Liquid temperature	Correction factor
-10°F	0.82
10°F	0.85
30°F	0.88
50°F	0.92
70°F	0.96
90°F	1.00
110°F	1.04
130°F	1.09

Dual position solenoid valve, type ICSH 25-80

Nominal capacities

Hotgas line

SI units

Capacity table for nominal conditions, Q_N [kW],

$T_{liq} = 10^\circ\text{C}$,

$P_{disch} = 10$ bar,

$\Delta P = 0.2$ bar

$T_{disch} = 80^\circ\text{C}$

Superheat = 8°C

R 744

Function module	Valve body size	K_v [m ³ /h]	Evaporating temperature [°C]							
			-50	-40	-30	-20	-10	0	10	20
ICS25-5	25	1.7	12.5	12.7	12.8	12.9	12.9	12.9	12.5	12.8
ICS25-10		3.5	25.7	26.2	26.5	26.6	26.6	26.3	25.8	26.4
ICS25-15		6	44.0	45.0	45.3	45.6	45.5	45.1	44.2	45.0
ICS25-20		8	59.0	60.0	60.2	60.7	60.7	60.1	59.0	60.0
ICS25-25		11.5	85.0	86.0	87.0	87.4	87.3	86.5	85.0	87.0
ICS32	32	17	125	127	128	129	129	128	125	128
ICS40	40	27	199	202	204	205	205	203	199	203
ICS50	50	44	324	329	332	334	334	331	324	331
ICS65	65	70	515	523	529	532	531	526	516	527
ICS80	80	85	626	636	642	646	645	640	626	640

Correction factor for discharge temperature (T_{disch}).

Correction factor for ΔP ($f_{\Delta P}$)

ΔP [bar]	Correction factor
0.2	1.00
0.25	0.89
0.3	0.82
0.4	0.71
0.5	0.63
0.6	0.58

Discharge temperature	Correction factor
50°C	0.96
60°C	0.97
80°C	1.00
90°C	1.01
100°C	1.03
110°C	1.04
120°C	1.06

Correction factor for liquid temperature (T_{liq}).

Liquid temperature	Correction factor
-20°C	0.52
-10°C	0.67
0°C	0.91
10°C	1.00
15°C	1.09

US units

Capacity table for nominal conditions, Q_N [Tons of Refrigeration],

$T_{liq} = 90^\circ\text{F}$,

$\Delta P = 3$ psi

$P_{disch} = 120$ psi,

$T_{disch} = 180^\circ\text{F}$

Superheat = 12°F

R 744

Function module	Valve body size	C_v [USgal/min]	Evaporating temperature [°F]							
			-60°F	-40°F	-20°F	0°F	20°F	40°F	60°F	80°F
ICS25-5	25	2	3.4	3.4	3.5	3.5	3.4	3.3	3.2	3.1
ICS25-10		4.1	6.9	7.0	7.1	7.1	7.0	6.8	6.6	6.4
ICS25-15		7	11.9	12.1	12.2	12.2	12.0	11.7	11.3	11.0
ICS25-20		9.3	15.8	16.1	16.2	16.2	16.0	15.6	15.1	14.7
ICS25-25		13.3	22.8	23.1	23.3	23.3	23.0	22.4	21.8	21.1
ICS32	32	20	33.7	34.1	34.5	34.5	34.0	33.1	32.2	31.2
ICS40	40	31	53.4	54.3	54.7	54.7	54.0	52.5	51.0	49.6
ICS50	50	51	87.0	88.4	89.0	89.0	88.0	85.5	83.3	80.8
ICS65	65	81	138	141	142	142	140	136	132	129
ICS80	80	98	167	169	171	171	168	164	159	154

Correction factor for discharge temperature (T_{disch}).

Correction factor for ΔP ($f_{\Delta P}$)

ΔP [psi]	Correction factor
3	1.00
4	0.87
5	0.79
6	0.72
7	0.66
8	0.62

Discharge temperature	Correction factor
120°F	0.95
140°F	0.97
180°F	1.00
200°F	1.02
210°F	1.02
230°F	1.04
250°F	1.05

Correction factor for liquid temperature (T_{liq}).

Liquid temperature	Correction factor
-10°F	0.48
10°F	0.64
30°F	0.88
50°F	1.00

Dual position solenoid valve, type ICSH 25-80

Nominal capacities

Hotgas line

SI units

Capacity table for nominal conditions, Q_N [kW],

$T_{liq} = 30^\circ\text{C}$,

$P_{disch} = 8 \text{ bar}$,

$\Delta P = 0.2 \text{ bar}$

$T_{disch} = 80^\circ\text{C}$

Superheat = 8°C

R 134a

Function module	Valve body size	K_v [m ³ /h]	Evaporating temperature [°C]						
			-40	-30	-20	-10	0	10	20
ICS25-5	25	1.7	5.1	5.4	5.6	5.9	6.1	6.3	6.5
ICS25-10		3.5	10.6	11.0	11.6	12.0	12.5	13.0	13.4
ICS25-15		6	18.1	19.0	19.8	20.6	21.5	22.3	23.0
ICS25-20		8	24.1	25.3	26.4	27.5	28.6	29.7	30.7
ICS25-25		11.5	34.7	36.0	38.0	39.6	41.0	42.7	44.0
ICS32	32	17	51.0	54.0	56.0	58.5	61.0	63.0	65.0
ICS40	40	27	82.0	85.0	89.0	93.0	97.0	100	104
ICS50	50	44	133	139	145	151	157	163	169
ICS65	65	70	211	221	231	241	251	260	269
ICS80	80	85	256	268	280	293	304	315	326

Correction factor for ΔP ($f_{\Delta P}$)

ΔP [bar]	Correction factor
0.2	1.00
0.25	0.89
0.3	0.82
0.4	0.71
0.5	0.63
0.6	0.58

Correction factor for discharge temperature (T_{disch}).

Discharge temperature	Correction factor
50°C	0.96
60°C	0.97
80°C	1.00
90°C	1.01
100°C	1.03
110°C	1.04
120°C	1.06

Correction factor for liquid temperature (T_{liq}).

Liquid temperature	Correction factor
-20°C	0.66
-10°C	0.70
0°C	0.76
10°C	0.82
20°C	0.90
30°C	1.00
40°C	1.13
50°C	1.29

R 134a

US units

Capacity table for nominal conditions, Q_N [Tons of Refrigeration],

$T_{liq} = 90^\circ\text{F}$,

$\Delta P = 3 \text{ psi}$

$P_{disch} = 120 \text{ psi}$,

$T_{disch} = 180^\circ\text{F}$

Superheat = 12°F

Function module	Valve body size	C_v [USgal/min]	Evaporating temperature [°F]						
			-40°F	-20°F	0°F	20°F	40°F	60°F	80°F
ICS25-5	25	2	1.4	1.5	1.5	1.6	1.7	1.7	1.8
ICS25-10		4.1	2.3	3.0	3.1	3.3	3.4	3.6	3.7
ICS25-15		7	4.9	5.1	5.4	5.6	5.9	6.1	6.3
ICS25-20		9.3	6.5	6.8	7.2	7.5	7.8	8.1	8.4
ICS25-25		13.3	9.3	9.8	10.3	10.8	11.3	11.7	12.1
ICS32	32	20	13.8	14.5	15.2	16.0	16.6	17.3	18.0
ICS40	40	31	21.9	23.0	24.2	25.3	26.5	27.5	28.5
ICS50	50	51	35.6	37.5	39.4	41.3	43.0	44.8	46.5
ICS65	65	81	56.7	59.7	62.9	65.7	68.5	71.3	74.0
ICS80	80	98	67	72	75	79	83	86	89

Correction factor for ΔP ($f_{\Delta P}$)

ΔP [psi]	Correction factor
3	1.00
4	0.87
5	0.79
6	0.72
7	0.66
8	0.62

Correction factor for discharge temperature (T_{disch}).

Discharge temperature	Correction factor
120°F	0.95
140°F	0.97
180°F	1.00
200°F	1.02
210°F	1.02
230°F	1.04
250°F	1.05

Correction factor for liquid temperature (T_{liq}).

Liquid temperature	Correction factor
-10°F	0.64
10°F	0.68
30°F	0.74
50°F	0.81
70°F	0.89
90°F	1.00
110°F	1.15
130°F	1.35

Dual position solenoid valve, type ICSH 25-80

Nominal capacities

Hotgas line

SI units

Capacity table for nominal conditions, Q_N [kW],

$T_{liq} = 30^\circ\text{C}$,

$P_{disch} = 12$ bar

$\Delta P = 0.2$ bar,

$T_{disch} = 80^\circ\text{C}$

Superheat = 8°C

R 404A

Function module	Valve body size	K_v [m ³ /h]	Evaporating temperature [°C]							
			-50	-40	-30	-20	-10	0	10	20
ICS25-5	25	1.7	4.8	5.1	5.4	5.7	6.0	6.3	6.6	6.8
ICS25-10		3.5	9.8	10.4	11.1	11.8	12.4	13.0	13.6	14.1
ICS25-15		6	16.7	18.0	19.0	20.2	21.3	22.3	23.3	24.2
ICS25-20		8	22.3	24.0	25.4	27.0	28.3	29.7	31.0	32.0
ICS25-25		11.5	32.0	34.0	36.5	38.5	40.7	42.7	44.6	46.0
ICS32	32	17	48.0	51.0	54.0	57.0	60.0	63.0	66.0	69.0
ICS40	40	27	75.0	81.0	86.0	91.0	96.0	100	105	109
ICS50	50	44	123	131	140	148	156	163	171	177
ICS65	65	70	195	208	222	235	248	260	271	282
ICS80	80	85	238	254	270	286	301	315	330	342

Correction factor for ΔP ($f_{\Delta P}$)

ΔP [bar]	Correction factor
0.2	1.00
0.25	0.89
0.3	0.82
0.4	0.71
0.5	0.63
0.6	0.58

Correction factor for discharge temperature (T_{disch}).

Discharge temperature	Correction factor
50°C	0.96
60°C	0.97
80°C	1.00
90°C	1.01
100°C	1.03
110°C	1.04
120°C	1.06

Correction factor for liquid temperature (T_{liq}).

Liquid temperature	Correction factor
-20°C	0.55
-10°C	0.60
0°C	0.66
10°C	0.74
20°C	0.85
30°C	1.00
40°C	1.23
50°C	1.68

R 404A

US units

Capacity table for nominal conditions, Q_N [Tons of Refrigeration],

$T_{liq} = 90^\circ\text{F}$,

$\Delta P = 3$ psi,

$P_{disch} = 120$ psi,

$T_{disch} = 180^\circ\text{F}$

Superheat = 12°F

Function module	Valve body size	C_v [USgal/min]	Evaporating temperature [°F]							
			-60°F	-40°F	-20°F	0°F	20°F	40°F	60°F	80°F
ICS25-5	25	2	1.2	1.3	1.4	1.5	1.6	1.7	1.8	1.8
ICS25-10		4.1	2.5	2.7	2.9	3.1	3.3	3.5	3.7	3.8
ICS25-15		7	4.4	4.7	5.0	5.4	5.7	6.0	6.3	6.5
ICS25-20		9.3	5.8	6.2	6.7	7.2	7.6	8.0	8.4	8.7
ICS25-25		13.3	8.4	8.9	9.6	10.3	10.9	11.5	12.0	12.5
ICS32	32	20	12.4	13.2	14.2	15.2	16.1	17.0	17.8	18.4
ICS40	40	31	19.6	21.0	22.6	24.1	25.6	27.0	28.2	29.3
ICS50	50	51	32.0	34.2	36.8	39.3	41.7	44.0	46.0	47.7
ICS65	65	81	51.0	54.3	58.5	62.5	66.3	70.0	73.0	76.0
ICS80	80	98	61	65	70	75	80	84	88	91

Correction factor for ΔP ($f_{\Delta P}$)

ΔP [psi]	Correction factor
3	1.00
4	0.87
5	0.79
6	0.72
7	0.66
8	0.62

Correction factor for discharge temperature (T_{disch}).

Discharge temperature	Correction factor
120°F	0.95
140°F	0.97
180°F	1.00
200°F	1.02
210°F	1.02
230°F	1.04
250°F	1.05

Correction factor for liquid temperature (T_{liq}).

Liquid temperature	Correction factor
-10°F	0.52
10°F	0.57
30°F	0.63
50°F	0.72
70°F	0.83
90°F	1.00
110°F	1.29
130°F	1.92

Dual position solenoid valve, type ICSH 25-80

ICSH 25

Ordering from the parts programme

Example (select from table I, II and III)

Valve body 25 D (1 in.)
027H2120
Table I

Function module ICS 25-25
027H2200
Table II

Top cover ICSH
027H0159
Table III

ICV 25 valve body w/different connections Table I

20 D (¾ in.)	25 D (1 in.)	32 D (1¼ in.)	40 D (1½ in.)
027H2128	027H2120	027H2129	027H2135
35 SD (1⅜ in. SA)	28 SA (1⅜ in.)	22 SA (¾ in.)	28 SD (1⅜ in.)
027H2134	027H2126	027H2125	027H2124
22 SD (¾ in.)	20 A (¾ in.)	25 A (1 in.)	32 A (1¼ in.)
027H2123	027H2131	027H2121	027H2130
20 SOC (¾ in.)	25 SOC (1 in.)	20 FPT (½ in.)	25 FPT (1 in.)
027H2132	027H2122	027H2133	027H2127

ICS 25 function module Table II

Description	Code Number
ICS 25-5	027H2201 *
ICS 25-10	027H2202 *
ICS 25-15	027H2203 *
ICS 25-20	027H2204 *
ICS 25-25	027H2200 *

ICSH 25 top cover Table III

Description	Code Number
Top cover ICSH	027H0159 *

*) Including bolts, one blanking plug (A+B) and 2 EVM NC

*) Including gasket and O-rings

D = Butt-weld DIN ; A = Butt-weld ANSI ; J = Butt-weld JIS ; SOC = Socket weld ANSI ; SD = Solder DIN ; SA = Solder ANSI ; FPT = Female Pipe Thread

Ordering complete factory assembled valve (body, function module and top cover)

Table A

Available connections								
	20 D (¾ in.)	25 D (1 in.)	32 D (1¼ in.)	40 D (1½ in.)	35 SD (1⅜ in. SA)	28 SA (1⅜ in.)	22 SA (¾ in.)	28 SD (1⅜ in.)
ICSH 25-25 *)		027H2309						
	22 SD (¾ in.)	20 A (¾ in.)	25 A (1 in.)	32 A (1¼ in.)	20 SOC (¾ in.)	25 SOC (1 in.)	20 FPT (½ in.)	25 FPT (1 in.)
ICSH 25-25 *)			027H2308			027H2307		

Select from parts programme

*) Including one blanking plug (A+B) and 2 EVM NC

Dual position solenoid valve, type ICSH 25-80

ICSH 32

Ordering from the parts programme

Example (select from table I, II and III)

Valve body 32 D (1 1/4 in.)
027H3120
Table I

Function module ICS 32
027H3200
Table II

Top cover ICSH
027H0164
Table III

ICV 32 valve body w/different connections *Table I*

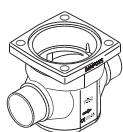

32 D (1 1/4 in.)	40 D (1 1/2 in.)	42 SA (1 1/8 in.)	42 SD (1 1/8 in.)
027H3120	027H3125	027H3127	027H3128
35 SD (1 1/8 in.SA)	32 A (1 1/4 in.)	32 SOC (1 1/4 in.)	40 A (1 1/2 in.)
027H3123	027H3121	027H3122	027H3126

D = Butt-weld DIN ; A = Butt-weld ANSI ; J = Butt-weld JIS ; SOC = Socket weld ANSI ; SD = Solder DIN ; SA = Solder ANSI ; FPT = Female Pipe Thread

ICS 32 function module *Table II*



Description	Code Number
ICS 32	027H3200 *

*) Including gasket and O-rings

ICSH 32 top cover *Table III*

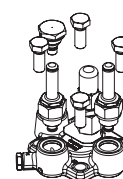

Description	Code Number
Top cover ICSH	027H0164 *

*) Including bolts, one blanking plug (A+B) and 2 EVM NC

Ordering complete factory assembled valve

(body, function module and top cover)

Table A

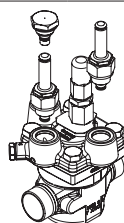

ICSH 32 *)	Available connections							
	32 D (1 1/4 in.)	40 D (1 1/2 in.)	42 SA (1 1/8 in.)	42 SD (1 1/8 in.)	35 SD (1 1/8 in.SA)	32 A (1 1/4 in.)	32 SOC (1 1/4 in.)	40 A (1 1/2 in.)
	027H3309					027H3378	027H3377	

Select from parts programme

*) Including one blanking plug (A+B) and 2 EVM NC

Dual position solenoid valve, type ICSH 25-80

ICSH 40

Ordering from the parts programme

Example (select from table I, II and III)

Valve body 50 D (2 in.)
027H4126
Table I

Function module ICS 40
027H4200
Table II

Top cover ICSH
027H0169
Table III

ICV 40 valve body w/different connections *Table I*

40 D (1½ in.)	50 D (2 in.)	42 SA (1¼ in.)	42 SD (1¼ in.)
027H4120	027H4126	027H4124	027H4123
40 A (1½ in.)	40 SOC (1½ in.)	50 A (2 in.)	
027H4121	027H4122	027H4127	

ICS 40 function module *Table II*

Description	Code Number
ICS 40	027H4200 *

*) Including gasket and O-rings

ICSH 40 top cover *Table III*

Description	Code Number
Top cover ICSH	027H0169 *

*) Including bolts, one blanking plug (A+B) and 2 EVM NC

D = Butt-weld DIN ; A = Butt-weld ANSI ; J = Butt-weld JIS ; SOC = Socket weld ANSI ; SD = Solder DIN ; SA = Solder ANSI ; FPT = Female Pipe Thread

Ordering complete factory assembled valve

(body, function module and top cover)

Table A

ICSH 40 *)	Available connections						
	40 D (1½ in.)	50 D (2 in.)	42 SA (1¼ in.)	42 SD (1¼ in.)	40 A (1½ in.)	40 SOC (1½ in.)	50 A (2 in.)
	027H4309				027H4308	027H4307	

Select from parts programme

*) Including one blanking plug (A+B) and 2 EVM NC

Dual position solenoid valve, type ICSH 25-80

ICSH 50

Ordering from the parts programme

Example (select from table I, II and III)

Valve body 65 D (2 1/2 in.)
027H5124
Table I

Function module ICS 40
027H5200
Table II

Top cover ICSH
027H0174
Table III

ICV 50 valve body w/different connections *Table I*

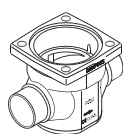

50 D (2 in.)	65 D (2 1/2 in.)	54 SD (2 1/4 in. SA)	50 A (2 in.)
027H5120	027H5124	027H5123	027H5121
50 SOC (2 in.)	65 A (2 1/2 in.)		
027H5122	027H5125		

ICS 50 function module *Table II*

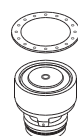

Description	Code Number
ICS 50	027H5200 *)

*) Including gasket and O-rings

ICSH 50 top cover *Table III*

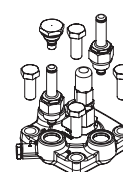

Description	Code Number
Top cover ICSH	027H0174 *)

*) Including bolts, one blanking plug (A+B) and 2 EVM NC

D = Butt-weld DIN ; A = Butt-weld ANSI ; J = Butt-weld JIS ; SOC = Socket weld ANSI ; SD = Solder DIN ; SA = Solder ANSI ; FPT = Female Pipe Thread

Ordering complete factory assembled valve

(body, function module and top cover)

Table A

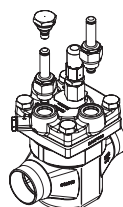

	Available connections					
	50 D (2 in.)	65 D (2 1/2 in.)	54 SD (2 1/4 in. SA)	65 A (2 1/2 in.)	50 A (2 in.)	50 SOC (2 in.)
ICSH 50 *)	027H5309				027H5308	027H5307

Select from parts programme

*) Including one blanking plug (A+B) and 2 EVM NC

Dual position solenoid valve, type ICSH 25-80

ICSH 65 and ICSH 80

Ordering from the parts programme

Example (select from table I, II and III)

Valve body 76 SD (2½ in.)
027H6124
Table I

Function module
ICS 65 **027H6200**
ICS 80 **027H8200**
Table II

Top cover ICSH
027H0179
027H0227
Table III

ICV 65 valve body w/different connections **Table I**

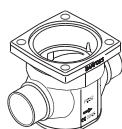

65 D (2½ in.)	65 A (2½ in.)	65 J (2½ in.)	80 D (3 in.)
027H6120	027H6121	027H6122	027H6126
80 A (3 in.)	67 SA (2 5/8 in.)	76 SD (3 in.)	65 SOC (2½ in.)
027H6127	027H6125	027H6124	027H6123

ICS 65/80 function module **Table II**



Description	Code Number
ICS 65	027H6200 *
ICS 80	027H8200 *

*) Including gasket and O-rings

ICSH 65/80 top cover **Table III**

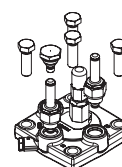

Description	Code Number
Top cover ICSH (65)	027H0179 *
Top cover ICSH (80)	027H0227 *

*) Including bolts, one blanking plug (A+B) and 2 EVM NC

D = Butt-weld DIN ; A = Butt-weld ANSI ; J = Butt-weld JIS ; SOC = Socket weld ANSI ; SD = Solder DIN ; SA = Solder ANSI ; FPT = Female Pipe Thread

Ordering complete factory assembled valve

(body, function module and top cover)

Table A

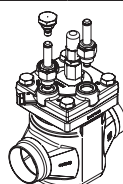

	Available connections							
	65 D (2½ in.)	65 A (2½ in.)	65 SOC (2½ in.)	80 D (3 in.)	80 A (3 in.)	67 SA (2 5/8 in.)	76 SD (3 in.)	65 J (2½ in.)
ICSH 65 *)	027H6309	027H6311	027H6308					
ICSH 80 *)				027H7302	027H7303			

Select from parts programme

*) Including one blanking plug (A+B) and 2 EVM NC



Note:

The capacity of the ICS 80 module can only be achieved when using the valve body with 80 D or A (3 in) connections. If any other ICV 65 valve body is used the capacity of the complete valve will be reduced by up to 6%.

Dual position solenoid valve, type ICSH 25-80

Accessories

ICV PM flanged valve housings

ICV PM flanged valve housings can replace the PM valves on already installed refrigeration systems.

Pressure range

The ICV PM valve housing is designed for a max. working pressure of 28 bar g / 406 psig and therefore a suitable replacement for PM valves in the service market. They also offer the same drop-in dimensions as the PM valves.

Description	Code no.
ICV 25 PM Valve housing	027H2119 *)
ICV 32 PM Valve housing	027H3129 *)
ICV 40 PM Valve housing	027H4128 *)
ICV 50 PM Valve housing	027H5127 **)
ICV 65 PM Valve housing	027H6128 **)

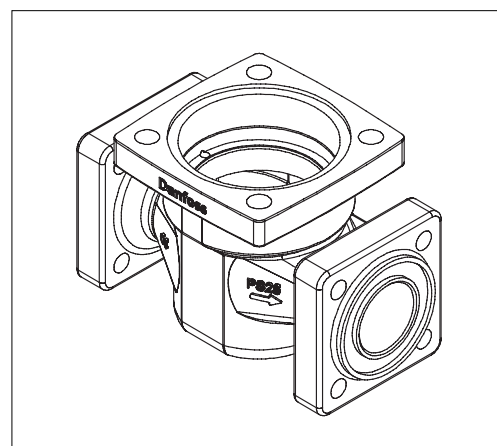

*) Includes ICV PM valve housing, flange gaskets and flange bolts.

***) Includes ICV PM valve housing, flange gaskets, flange bolts and flange nuts.

Function modules and top covers must be ordered separately (see the section "Ordering").

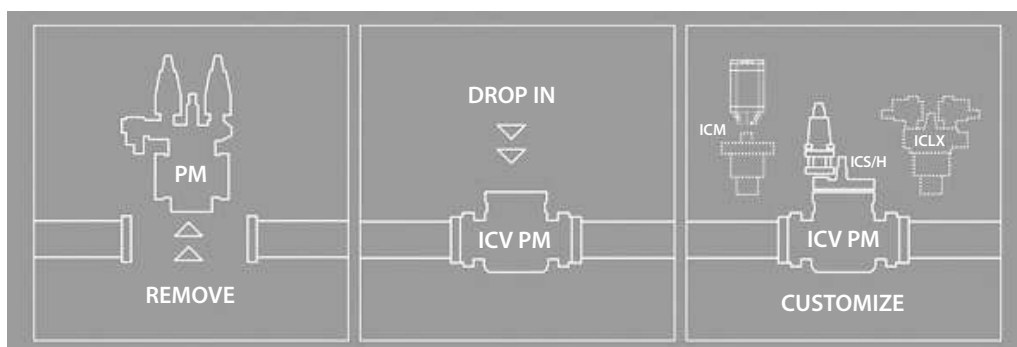

Dual position solenoid valve, type ICSH 25-80

Accessories

ICV (H)A4A flanged valve housings

ICV (H)A4A flanged valve housings can replace the (H)A4A valves on already installed refrigeration systems.

Pressure range

The ICV (H)A4A valve housing is designed for a max. working pressure of 28 bar g / 406 psig and therefore a suitable replacement for (H)A4A valves in the service market. They also offer the same drop-in dimensions as the (H)A4A valves.

Description	Code no.
ICV 25 (H)A4A Valve housing	027H2304 *)
ICV 32 A4A Valve housing	027H3130 *)
ICV 32 HA4A Valve housing	027H3131 *)
ICV 40 (H)A4A Valve housing	027H4129 *)
ICV 50 (H)A4A Valve housing	027H5128 *
ICV 65 (H)A4A Valve housing	027H6129 *

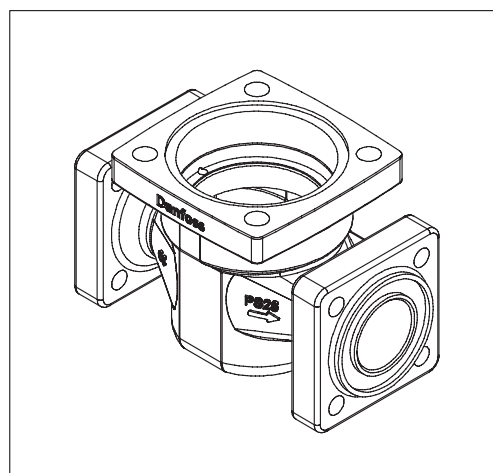

*) Includes ICV (H)A4A valve housing, flange gaskets, flange bolts and flange nuts.

Function modules and top covers must be ordered separately (see the section "Ordering").

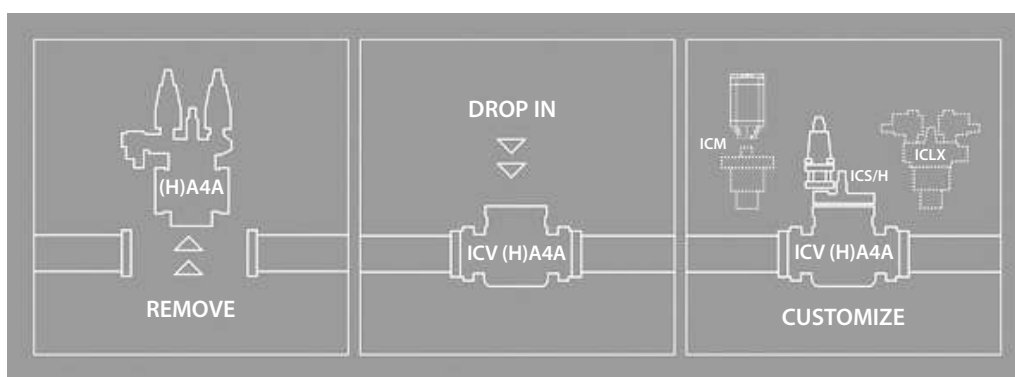

Blanking plug A + B for pilot valves

Description	Code number
Blanking plug incl. flat gasket	027F1046

Dual position solenoid valve, type ICSH 25-80

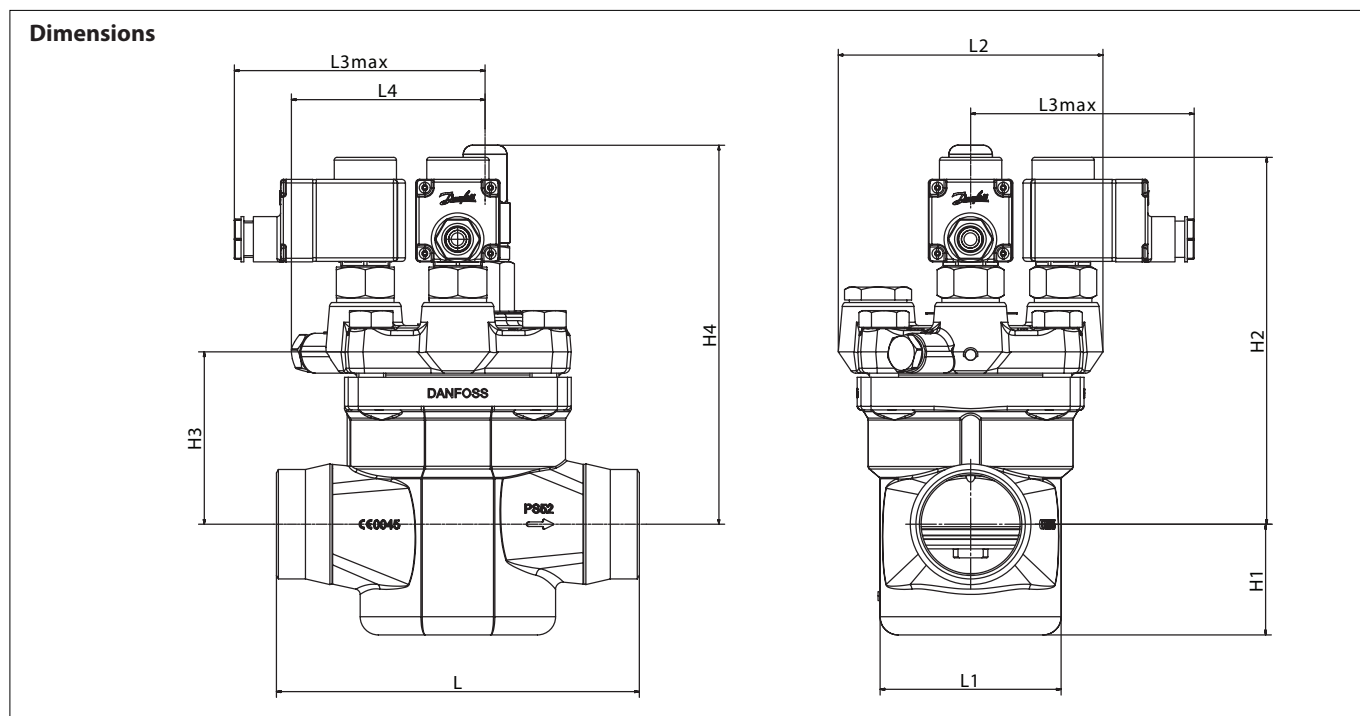

ICSH 25-25	L		
	DIN	A	SOC
mm	135	135	147
in	5.31	5.31	5.79

ICSH 25-25	L1	L2	L3max(s1)	L3max(S-2)	L4	H1	H2	H3	H4	Weight
mm	65	146.5	138	123	100.5	39.5	168.5	61	174	3.8 Kg
in	2.56	5.77	5.43	4.84	3.96	1.56	6.63	2.40	6.85	7.93lb

ICSH 32	L		
	DIN	A	SOC
mm	145	145	148
in	5.71	5.71	5.83

ICSH 32	L1	L2	L3max(s1)	L3max(S-2)	L4	H1	H2	H3	H4	Weight
mm	75	146.5	138	123	102	42.5	182	72	187.6	5.1
in	2.95	5.77	5.43	4.84	4.02	1.67	7.17	2.83	7.39	11.1lb

ICSH 40	L		
	DIN	A	SOC
mm	160	160	180
in	6.30	6.30	7.09

ICSH 40	L1	L2	L3max(s1)	L3max(S-2)	L4	H1	H2	H3	H4	Weight
mm	86	146	138	123	102	51.5	186.5	78	193	6.5 Kg
in	3.39	5.75	5.43	4.84	4.02	2.03	7.34	3.07	7.60	14lb

Dual position solenoid valve, type ICSH 25-80

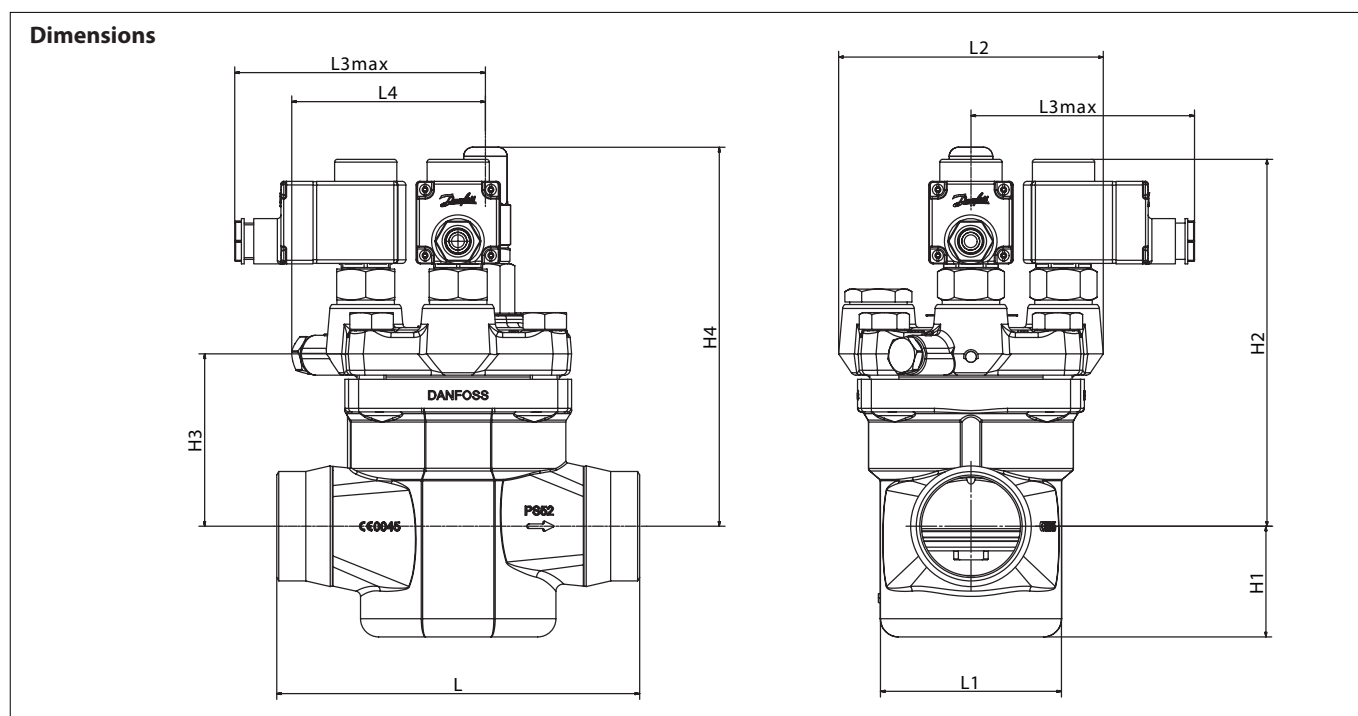

ICSH 50	L		
	DIN	A	SOC
mm	200	200	216
in	7.87	7.87	8.50

ICSH 50	L1	L2	L3max(s1)	L3max(S-2)	L4	H1	H2	H3	H4	Weight
mm	100	146	138	123	107	61	202	95	209	9.4 Kg
in	3.94	5.75	5.43	4.84	4.21	2.40	7.95	3.74	8.23	20.3lb

ICSH 65	L		
	DIN	A	SOC
mm	230	230	230
in	9.06	9.06	9.06

ICSH 65	L1	L2	L3max(s1)	L3max(S-2)	L4	H1	H2	H3	H4	Weight
mm	130	145.6	138	123	106.7	69	222.5	114.5	232	13.7 Kg
in	5.12	5.73	5.43	4.84	4.20	2.72	8.76	4.51	9.13	29.8lb

ICSH 80	L		
	DIN	A	
mm	245	245	
in	9.65	9.65	

ICSH 80	L1	L2	L3max(s1)	L3max(S-2)	L4	H1	H2	H3	H4	Weight
mm	130	145.6	138	123	106.7	69	222.5	112.5	232	13.7 Kg
in	5.12	5.73	5.43	4.84	4.20	2.72	8.76	4.43	9.13	29.8lb

Dual position solenoid valve, type ICSH 25-80

Connections

D: Butt-weld (EN 10220)

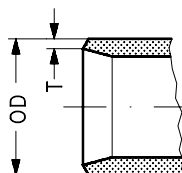

Size mm	Size in.	OD mm	T mm	OD in.	T in.
20	(3/4)	26.9	2.3	1.059	0.091
25	(1)	33.7	2.6	1.327	0.103
32	(1 1/4)	42.4	2.6	1.669	0.102
40	(1 1/2)	48.3	2.6	1.902	0.103
50	(2)	60.3	2.9	2.37	0.11
65	(2 1/2)	76.1	2.9	3	0.11
80	(3)	88.9	3.2	3.50	0.13

A: Butt-weld ANSI (B 36.10)

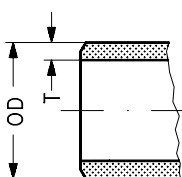

Size mm	Size in.	OD mm	T mm	OD in.	T in.	Schedule
(20)	3/4	26.9	4.0	1.059	0.158	80
(25)	1	33.7	4.6	1.327	0.181	80
(32)	1 1/4	42.4	4.9	1.669	0.193	80
(40)	1 1/2	48.3	5.1	1.902	0.201	80
(50)	2	60.3	3.9	2.37	0.15	40
(65)	2 1/2	73.0	5.2	2.87	0.20	40
(80)	3	88.9	5.5	3.50	0.22	40

SOC:

Socket welding ANSI (B 16.11)

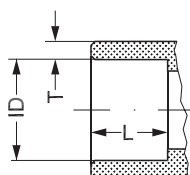

Size mm	Size in.	ID mm	T mm	ID in.	T in.	L mm	L in.
(20)	3/4	27.2	4.6	1.071	0.181	13	0.51
(25)	1	33.9	7.2	1.335	0.284	13	0.51
(32)	1 1/4	42.7	6.1	1.743	0.240	13	0.51
(40)	1 1/2	48.8	6.6	1.921	0.260	13	0.51
(50)	2	61.2	6.2	2.41	0.24	16	0.63
(65)	2 1/2	74	8.8	2.91	0.344	16	0.63

SD: Soldering (EN 1254-1)

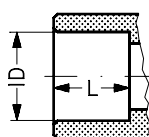

Size mm	Size in.	ID mm	ID in.	L mm	L in.
22		22.08		16.5	
28		28.08		26	
35		35.07		25	
42		42.07		28	
54		54.09		33	
76		76.1		33	

SA: Soldering (ANSI B 16.22)

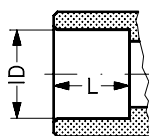

Size in.	ID in.	L in.
7/8	0.875	0.650
1 1/8	1.125	1.024
1 3/8	1.375	0.984
1 1/2	1.625	1.102
2 1/8	2.125	1.300
2 1/2	2.625	1.300

Solenoid valves

EVRA and EVRAT

Contents

	Page
Technical data	57
Ordering valve with coil	58
Ordering valve without coil	58
Rated capacity	59
Material specification	69
Dimensions and weight	70

Solenoid valves

EVRA and EVRAT



EVRA is a direct or servo operated solenoid valve for liquid, suction and hot gas lines with ammonia or fluorinated refrigerants.

EVRA valves are supplied complete or as separate components, i.e. valve body, coil and flanges can be ordered separately.

EVRAT is an assisted lift, servo operated solenoid valve for liquid, suction and hot gas lines with ammonia and fluorinated refrigerants.

EVRAT is specially designed to open - and stay open - at a pressure drop of 0 bar. The EVRAT solenoid valve is thus suitable for use in all plant where the required opening differential pressure is 0 bar.

EVRAT is available as components, i.e. valve body, flanges and coil must be ordered separately.

EVRAT 10, 15 and 20 all have spindle for manual operation.

Technical data

- Refrigerants: Applicable to HCFC, HFC and R717 (Ammonia)
- Temperature of medium: -40 – 105 °C
Max. 130 °C during defrosting.
- Ambient temperature and enclosure for coil see "Coils for solenoid valves", AI237186440089
- Classification: DNV, CRN, BV, EAC etc.
To get an updated list of certification on the products please contact your local Danfoss Sales Company

Type	Opening differential pressure with standard coil (Δp bar)				Temperature of medium [°C]	Max. working pressure PB [bar]	k _v -value ¹⁾ [m ³ /h]
	Max. (= MOPD) liquid ²⁾						
	Min.	10 W AC	12 W AC	20 W DC			
EVRA 3	0.00	21	25	14	-40 – 105	42	0.23
EVRA 10	0.05	21	25	18	-40 – 105	42	1.5
EVRAT 10	0.00	14	21	16	-40 – 105	42	1.5
EVRA 15	0.05	21	25	18	-40 – 105	42	2.7
EVRAT 15	0.00	14	21	16	-40 – 105	42	2.7
EVRA 20 with AC coil	0.05	21	25	13	-40 – 105	42	4.5
EVRA 20 with DC coil	0.05	19	21	16	-40 – 105	42	4.5
EVRAT 20	0.00	14	21	13	-40 – 105	42	4.5
EVRA 25	0.20	21	25	14	-40 – 105	42	10.0
EVRA 32	0.20	21	25	14	-40 – 105	42	16.0
EVRA 40	0.20	21	25	14	-40 – 105	42	25.0

¹⁾ The k_v value is the water flow in m³/h at a pressure drop across valve of 1 bar, ρ = 1000 kg/m³.

²⁾ MOPD for media in gas form is approx. 1 bar greater.

Solenoid valves type EVRA and EVRAT



Ordering valve with coil

Type	Manual Stem	Inlet connection type	Orifice size [mm]	Max OPD 10W AC [bar]	Max OPD 20W DC [bar]	Coil type	Coil connection	Supply voltage [V] AC	Frequency [Hz]	Power consumption [W]	Singlepack/ Multipack (12 pcs.)	Code number
EVRA 3	No	Flange*	3	21	14	BF230AS	Cable (1 m/3.3 ft)	220 - 230	50	10	Multipack	032F310231
EVRA 3	No	Flange*	3	21	14	BE230AS	Connection Box	220 - 230	50	10	Multipack	032F310331
EVRA 3	No	Flange*	3	21	14	BE230CS	Connection Box	220 - 230	50/60	10	Multipack	032F310332
EVRA 10	No	Flange*	10	21	18	BF230AS	Connection Box	220 - 230	50	10	Multipack	032F620831
EVRA 10	Yes	Flange*	10	21	18	BE230AS	Cable (1 m/3.3 ft)	220 - 230	50	10	Singlepack	032F621231
EVRA 10	Yes	Flange*	10	21	18	BE230AS	Connection Box	220 - 230	50	10	Singlepack	032F621331
EVRA 10	Yes	Flange*	10	21	18	BE230CS	Connection Box	220 - 230	50/60	10	Singlepack	032F621332
EVRA 15	No	Flange*	15	21	18	BF230AS	Cable (1 m/3.3 ft)	220 - 230	50	10	Singlepack	032F621731
EVRA 15	No	Flange*	15	21	18	BF230CS	Cable (1 m/3.3 ft)	220 - 230	50/60	10	Singlepack	032F621732
EVRA 15	No	Flange*	15	21	18	BE230AS	Connection Box	220 - 230	50	10	Singlepack	032F621831
EVRA 15	No	Flange*	15	21	18	BE230CS	Connection Box	220 - 230	50/60	10	Singlepack	032F621832
EVRA 20	No	Flange*	20	21	13	BF230AS	Cable (1 m/3.3 ft)	220 - 230	50	10	Singlepack	032F622231
EVRA 20	No	Flange*	20	21	13	BE230AS	Connection Box	220 - 230	50	10	Singlepack	032F622331
EVRA 20	No	Flange*	20	21	13	BE230CS	Connection Box	220 - 230	50/60	10	Singlepack	032F622332
EVRA 25	Yes	Flange*	25	21	14	BE230CS	Connection Box	220 - 230	50/60	10	Singlepack	032F803432



Ordering valve without coil

Type	Manual Stem	Inlet connection type	Inlet size [in]	Orifice size [mm]	Max OPD 10W AC [bar]	Max OPD 12W AC [bar]	Max OPD 20W DC [bar]	Required coil type**	Singlepack/ Multipack (12 pcs.)	Code number
EVRA 3	No	Flange*		3	21	25	14	AC / DC	Multipack	032F3050
EVRA 10	Yes	Flange*		10	21	25	18	AC / DC	Singlepack	032F6210
EVRA 10	No	Flange*		10	21	25	18	AC / DC	Singlepack	032F6211
EVRAT 10	Yes	Flange*		10	14	21	16	AC / DC	Singlepack	032F6214
EVRA 15	Yes	Flange*		15	21	25	18	AC / DC	Singlepack	032F6215
EVRAT 15	Yes	Flange*		15	14	21	16	AC / DC	Singlepack	032F6216
EVRAT 20	Yes	Flange*		20	14	21	13	AC / DC	Singlepack	032F6219
EVRA 20	Yes	Flange*		20	21	25	13	AC	Singlepack	032F6220
EVRA 20	Yes	Flange*		20	19	21	16	AC / DC	Singlepack	032F6221
EVRA 25	Yes	Flange*		25	21	25	14	AC / DC	Singlepack	032F6225
EVRA 25	No	Flange*		25	21	25	14	AC / DC	Singlepack	032F6226
EVRA 32	Yes	Butt weld DIN	1 1/4	22.2	21	25	14	AC / DC	Singlepack	042H1126
EVRA 32	No	Butt weld DIN	1 1/4	22.2	21	25	14	AC / DC	Singlepack	042H1127
EVRA 40	Yes	Butt weld DIN	1 1/2	25.4	21	25	14	AC / DC	Singlepack	042H1128
EVRA 40	No	Butt weld DIN	1 1/2	25.4	21	25	14	AC / DC	Singlepack	042H1129
EVRA 32	Yes	Butt weld DIN	1 1/2	22.2	21	25	14	AC / DC	Singlepack	042H1131
EVRA 40	Yes	Butt weld DIN	2	25.4	21	25	14	AC / DC	Singlepack	042H1132
EVRA 32	Yes	Butt weld ANSI 36.10	1 1/4	22.2	21	25	14	AC / DC	Singlepack	042H1140
EVRA 32	Yes	Butt weld ANSI 36.10	1 1/2	22.2	21	25	14	AC / DC	Singlepack	042H1141
EVRA 40	Yes	Butt weld ANSI 36.10	1 1/2	25.4	21	25	14	AC / DC	Singlepack	042H1142
EVRA 40	Yes	Butt weld ANSI 36.10	2	25.4	21	25	14	AC / DC	Singlepack	042H1143

* Includes flange gaskets and bolts. For ordering flanges; please download the data sheet AI249786497379 from www.danfoss.com

** For ordering coils; please download the data sheet AI237186440089 from www.danfoss.com

Solenoid valves type EVRA and EVRAT

Rated capacity

Type	Rated capacity ¹⁾ [kW]											
	Liquid				Suction vapour				Hot gas			
	R717	R22	R134a	R404A	R717	R22	R134a	R404A	R717	R22	R134a	R404A
EVRA 3	21.8	4.6	4.3	3.2				6.5	2.1	1.7	1.7	
EVRA/T 10	142.0	30.2	27.8	21.1	9.0	3.4	2.5	3.1	42.6	13.9	11.0	11.3
EVRA/T 15	256.0	54.4	50.1	38.0	16.1	6.2	4.4	5.5	76.7	24.9	19.8	20.3
EVRA/T 20	426.0	90.6	83.5	63.3	26.9	10.3	7.3	9.2	128.0	41.5	32.9	33.9
EVRA 25	947.0	201.0	186.0	141.0	59.7	22.8	16.3	20.4	284.0	92.3	73.2	75.3
EVRA 32	1515.0	322.0	297.0	225.0	95.5	36.5	26.1	32.6	454.0	148.0	117.0	120.0
EVRA 40	2368.0	503.0	464.0	351.0	149.0	57.0	40.8	51.0	710.0	231.0	183.0	188.0

¹⁾ Rated liquid and suction vapour capacity is based on evaporating temperature $t_e = -10\text{ °C}$, liquid temperature ahead of valve $t_l = +25\text{ °C}$, and pressure drop across valve $\Delta p = 0.15\text{ bar}$.

Rated hot gas capacity is based on condensing temperature $t_c = +40\text{ °C}$, pressure drop across valve $\Delta p = 0.8\text{ bar}$, hot gas temperature $t_h = +65\text{ °C}$, and subcooling of refrigerant $\Delta t_{sub} = 4\text{ K}$.

Capacity

Liquid capacity Q_l kW

Type	Liquid capacity Q_e kW at pressure drop across valve Δp bar				
	0.1	0.2	0.3	0.4	0.5

R 717 (NH₃)

EVRA 3	17.8	25.1	30.8	35.6	39.8
EVRA/T 10	116.0	164.0	201.0	232.0	259.0
EVRA/T 15	209.0	295.0	362.0	418.0	467.0
EVRA/T 20	348.0	492.0	603.0	696.0	778.0
EVRA 25	773.0	1093.0	1340.0	1547.0	1729.0
EVRA 32	1237.0	1749.0	2144.0	2475.0	2766.0
EVRA 40	1933.0	2734.0	3349.0	3867.0	4322.0

R 22

EVRA 3	3.8	5.3	6.6	7.6	8.5
EVRA/T 10	24.7	34.9	42.7	49.3	55.1
EVRA/T 15	44.4	62.8	76.9	88.8	99.2
EVRA/T 20	73.9	105.0	128.0	148.0	165.0
EVRA 25	165.0	232.0	285.0	329.0	368.0
EVRA 32	263.0	372.0	455.0	526.0	588.0
EVRA 40	411.0	581.0	712.0	822.0	919.0

R 134a

EVRA 3	3.5	4.9	6.0	7.0	7.8
EVRA/T 10	22.7	32.2	39.4	45.5	50.8
EVRA/T 15	40.9	57.9	70.9	81.8	91.5
EVRA/T 20	68.2	96.5	118.0	136.0	153.0
EVRA 25	152.0	214.0	263.0	303.0	339.0
EVRA 32	243.0	343.0	420.0	485.0	542.0
EVRA 40	379.0	536.0	656.0	758.0	847.0

R 404A

EVRA 3	2.6	3.7	4.6	5.3	5.9
EVRA/T 10	17.2	24.3	29.8	34.4	38.5
EVRA/T 15	31.0	43.8	53.7	62.0	69.3
EVRA/T 20	51.7	73.0	89.5	103.0	116.0
EVRA 25	115.0	162.0	199.0	230.0	257.0
EVRA 32	184.0	260.0	318.0	367.0	411.0
EVRA 40	287.0	406.0	497.0	574.0	642.0

Capacities are based on liquid temperature $t_l = 25\text{ °C}$ ahead of valve, evaporating temperature $t_e = -10\text{ °C}$, and superheat 0 K.

Correction factors

When sizing valves, the plant capacity must be multiplied by a correction factor depending on liquid temperature t_l ahead of valve/evaporator. When the corrected capacity is known, the selection can be made from the table.

t_v °C	-10	0	+10	+20	+25	+30	+40	+50
R 717 (NH ₃)	0.84	0.88	0.92	0.97	1.0	1.03	1.09	1.16
R 22, R 134a	0.76	0.81	0.88	0.96	1.0	1.05	1.16	1.31
R 404A	0.70	0.76	0.84	0.94	1.0	1.07	1.24	1.47

Solenoid valves type EVRA and EVRAT

Capacity (continued)

Suction vapour capacity Q_e kW

Type	Pressure drop across valve Δp bar	Suction vapour capacity Q_e kW at evaporating temperature t_e °C					
		-40	-30	-20	-10	0	10

R 717 (NH₃)

EVRA/T 10	0.1	3.4	4.5	5.9	7.3	8.9	10.6
	0.15	4.0	5.4	7.0	9.0	10.9	13.0
	0.2	4.5	6.1	7.9	10.0	12.6	15.0
EVRA/T 15	0.1	6.1	8.1	10.7	13.2	16.0	19.1
	0.15	7.2	9.7	12.5	16.1	19.6	23.4
	0.2	8.0	11.0	14.2	18.0	22.6	27.0
EVRA/T 20	0.1	10.2	13.5	17.8	21.9	26.6	31.9
	0.15	12.1	16.1	20.9	26.9	32.6	39.0
	0.2	13.4	18.3	23.7	29.9	37.7	45.1
EVRA 25	0.1	22.6	30.0	39.5	48.7	59.2	70.8
	0.15	26.7	35.9	46.3	59.7	72.5	86.7
	0.2	29.8	40.5	52.7	66.4	83.7	100.0
EVRA 32	0.1	36.2	47.8	63.2	77.9	94.7	113.0
	0.15	42.7	57.4	74.1	95.5	116.0	139.0
	0.2	47.7	64.8	84.3	106.0	134.0	160.0
EVRA 40	0.1	56.5	74.8	98.8	122.0	148.0	177.0
	0.15	66.8	89.8	116.0	149.0	181.0	217.0
	0.2	74.5	101.0	132.0	166.0	209.0	251.0

R 22

EVRA/T 10	0.1	1.4	1.8	2.3	2.8	3.4	4.0
	0.15	1.6	2.1	2.7	3.4	4.1	4.9
	0.2	1.8	2.4	3.1	3.8	4.8	5.6
EVRA/T 15	0.1	2.5	3.2	4.1	5.0	6.1	7.2
	0.15	2.9	3.8	4.8	6.2	7.4	8.8
	0.2	3.3	4.3	5.5	6.8	8.6	10.2
EVRA/T 20	0.1	4.1	5.3	6.8	8.4	10.1	12.0
	0.15	4.9	6.4	8.1	10.3	12.3	14.7
	0.2	5.5	7.2	9.2	11.4	14.3	16.9
EVRA 25	0.1	9.1	11.8	15.2	18.6	22.4	26.6
	0.15	10.9	14.2	17.9	22.8	27.4	32.6
	0.2	12.2	16.1	20.4	25.3	31.7	37.6
EVRA 32	0.1	14.6	18.9	24.3	29.8	35.8	42.6
	0.15	17.4	22.7	28.8	36.5	43.8	52.2
	0.2	19.6	25.7	32.6	40.5	50.7	60.2
EVRA 40	0.1	22.8	29.5	38.1	46.5	56.0	66.5
	0.15	27.2	35.4	45.0	57.0	68.6	81.5
	0.2	30.5	40.2	51.0	63.3	79.2	94.0

Capacities are based on liquid temperature $t_l = 25$ °C ahead of evaporator.
The table values refer to the evaporator capacity and are given as a function of evaporating temperature t_e and pressure drop Δp across valve.
Capacities are based on dry, saturated vapour ahead of valve.
During operation with superheated vapour ahead of valve, the capacities are reduced by 4% for each 10 K superheat.

Correction factors

When sizing valves, the evaporator capacity must be multiplied by a correction factor depending on liquid temperature t_l ahead of expansion valve.
When the corrected capacity is known, the selection can be made from the table.

t_v °C	-10	0	10	20	25	30	40	50
R 717 (NH ₃)	0.84	0.88	0.92	0.97	1.0	1.03	1.09	1.16
R 22	0.76	0.81	0.88	0.96	1.0	1.05	1.16	1.31

Solenoid valves type EVRA and EVRAT

Capacity (continued)

Suction vapour capacity Q_e kW

Type	Pressure drop across valve Δp bar	Suction vapour capacity Q_e kW at evaporating temperature t_e °C					
		-40	-30	-20	-10	0	10

R 134a

EVRA/T 10	0.1	0.87	1.2	1.6	2.1	2.6	3.2
	0.15	0.99	1.4	1.9	2.4	3.2	3.9
	0.2	1.1	1.6	2.1	2.8	3.5	4.5
EVRA/T 15	0.1	1.6	2.1	2.8	3.8	4.7	5.7
	0.15	1.8	2.5	3.4	4.4	5.7	7.0
	0.2	2.0	2.8	3.8	5.0	6.3	8.1
EVRA/T 20	0.1	2.6	3.6	4.7	6.3	7.8	9.5
	0.15	3.0	4.2	5.6	7.3	9.5	11.7
	0.2	3.3	4.7	6.4	8.3	10.5	13.5
EVRA 25	0.1	5.8	7.9	10.5	13.9	17.2	21.1
	0.15	6.6	9.3	12.5	16.3	21.1	25.9
	0.2	7.3	10.4	14.1	18.5	23.4	29.9
EVRA 32	0.1	9.3	12.6	16.8	22.2	27.7	33.8
	0.15	10.6	14.9	20.0	26.1	33.8	41.4
	0.2	11.7	16.6	22.6	29.6	37.4	47.8
EVRA 40	0.1	14.5	19.8	26.3	34.8	43.3	52.8
	0.15	16.5	23.3	31.3	40.8	52.8	64.8
	0.2	18.3	26.0	35.3	46.3	58.5	74.8

R 404A

EVRA/T 10	0.1	1.2	1.5	2.0	2.5	3.1	3.7
	0.15	1.4	1.8	2.4	3.1	3.8	4.6
	0.2	1.6	2.1	2.7	3.4	4.3	5.3
EVRA/T 15	0.1	2.1	2.7	3.6	4.5	5.5	6.6
	0.15	2.5	3.3	4.3	5.5	6.8	8.2
	0.2	2.8	3.7	4.9	6.1	7.8	9.5
EVRA/T 20	0.1	3.5	4.6	6.0	7.5	9.2	11.1
	0.15	4.1	5.5	7.1	9.2	11.3	13.6
	0.2	4.6	6.2	8.1	10.2	13.0	15.8
EVRA 25	0.1	7.7	10.1	13.3	16.6	20.4	24.6
	0.15	9.1	12.1	15.8	20.4	25.0	30.3
	0.2	10.3	13.8	18.0	22.7	28.8	35.0
EVRA 32	0.1	12.3	16.2	21.3	26.6	32.6	39.4
	0.15	14.6	19.4	25.3	32.6	40.0	48.5
	0.2	16.5	22.0	28.8	36.3	46.1	56.0
EVRA 40	0.1	19.3	25.3	33.3	41.5	51.0	61.5
	0.15	22.9	30.3	39.5	51.0	62.5	75.6
	0.2	25.8	34.5	45.0	56.8	72.1	87.5

Capacities are based on liquid temperature $t_l = 25$ °C ahead of evaporator.
The table values refer to the evaporator capacity and are given as a function of evaporating temperature t_e and pressure drop Δp across valve.
Capacities are based on dry, saturated vapour ahead of valve.
During operation with superheated vapour ahead of valve, the capacities are reduced by 4% for each 10 K superheat.

Correction factors

When sizing valves, the evaporator capacity must be multiplied by a correction factor depending on liquid temperature t_l ahead of expansion valve. When the corrected capacity is known, the selection can be made from the table.

t_l °C	-10	0	10	20	25	30	40	50
R 134a	0.76	0.81	0.88	0.96	1.0	1.05	1.16	1.31
R 404A	0.70	0.76	0.84	0.94	1.0	1.07	1.24	1.47

Solenoid valves type EVRA and EVRAT

Capacity (continued)

R 717 (NH₃)

Hot gas capacity Q_h kW

Type	Pressure drop across valve Δp bar	Hot gas capacity Q_e kW				
		Evaporating temp. $t_e = -10$ °C. Hot gas temp. $t_h = t_c$ 25 °C. Subcooling $\Delta t_{sub} = 4$ K				
		Condensing temperature t_c °C				
		20	30	40	50	60
EVRA 3	0.1	1.8	2.1	2.3	2.5	2.6
	0.2	2.6	2.9	3.2	3.5	3.7
	0.4	3.8	4.2	4.6	4.9	5.3
	0.8	5.1	6.0	6.5	7.1	7.6
	1.6	7.4	8.3	9.1	9.9	10.9
EVRA/T 10	0.1	12.0	13.4	14.7	16.0	17.2
	0.2	17.1	19.0	20.9	22.7	24.4
	0.4	24.5	27.1	29.7	32.2	34.7
	0.8	34.0	39.0	42.6	46.1	49.5
	1.6	48.5	53.8	59.1	64.3	71.3
EVRA/T 15	0.1	21.7	24.1	26.4	28.8	31.0
	0.2	30.8	34.2	37.5	40.8	44.0
	0.4	44.1	48.8	53.5	58.0	62.4
	0.8	61.2	70.3	76.7	83.0	89.1
	1.6	87.4	96.9	106.0	116.0	128.0
EVRA/T 20	0.1	36.1	40.1	44.0	48.0	51.7
	0.2	51.4	57.0	62.6	68.0	73.2
	0.4	73.5	81.3	89.1	96.7	104.0
	0.8	102.0	117.0	128.0	138.0	148.0
	1.6	146.0	161.0	177.0	193.0	214.0
EVRA 25	0.1	80.2	89.1	98.0	107.0	115.0
	0.2	114.0	127.0	139.0	151.0	163.0
	0.4	163.0	181.0	198.0	215.0	231.0
	0.8	227.0	260.0	284.0	307.0	330.0
	1.6	324.0	358.0	394.0	429.0	475.0
EVRA 32	0.1	128.0	143.0	157.0	171.0	184.0
	0.2	183.0	203.0	223.0	242.0	260.0
	0.4	261.0	289.0	317.0	344.0	370.0
	0.8	362.0	416.0	455.0	492.0	528.0
	1.6	518.0	574.0	631.0	688.0	761.0
EVRA 40	0.1	201.0	223.0	244.0	267.0	287.0
	0.2	286.0	317.0	348.0	378.0	407.0
	0.4	408.0	452.0	495.0	537.0	578.0
	0.8	566.0	650.0	710.0	769.0	825.0
	1.6	809.0	897.0	986.0	1074.0	1188.0

An increase in hot gas temperature t_h of 10 K, based on $t_h = t_c$ 25 °C, reduces valve capacity approx. 2% and vice versa.

A change in evaporating temperature t_e changes valve capacity; see correction factor table below.

Correction factor

When sizing valves, the table value must be multiplied by a correction factor depending on evaporating temperature t_e .

t_e °C	-40	-30	-20	-10	0	10
R 717 (NH ₃)	0.89	0.91	0.96	1.0	1.06	1.10

Solenoid valves type EVRA and EVRAT

Capacity
(continued)

Hot gas capacity Q_h kW

R 22

Type	Pressure drop across valve Δp bar	Hot gas capacity Q_e kW				
		Evaporating temp. $t_e = -10$ °C. Hot gas temp. $t_h = t_c = 25$ °C. Subcooling $\Delta t_{sub} = 4$ K				
		Condensing temperature t_c °C				
		20	30	40	50	60
EVRA 3	0.1	0.68	0.72	0.76	0.78	0.79
	0.2	0.97	1.0	1.1	1.1	1.1
	0.4	1.4	1.5	1.5	1.6	1.6
	0.8	1.9	2.0	2.1	2.3	2.3
	1.6	2.7	2.9	3.0	3.1	3.2
EVRA/T 10	0.1	4.4	4.7	4.9	5.1	5.2
	0.2	6.3	6.7	7.0	7.2	7.3
	0.4	9.0	9.6	10.0	10.3	10.4
	0.8	12.4	13.2	13.9	14.7	14.9
	1.6	17.5	18.6	19.6	20.2	20.5
EVRA/T 15	0.1	8.0	8.5	8.9	9.2	9.3
	0.2	11.4	12.1	12.6	13.0	13.2
	0.4	16.3	17.2	18.0	18.5	18.7
	0.8	22.3	23.1	24.9	26.5	26.8
	1.6	31.5	33.5	35.2	36.4	36.9
EVRA/T 20	0.1	13.3	14.1	14.8	15.3	15.5
	0.2	19.0	20.1	21.0	21.7	22.0
	0.4	27.1	28.7	30.0	30.9	31.2
	0.8	37.1	38.4	41.5	44.2	44.6
	1.6	52.5	55.9	58.6	60.6	61.5
EVRA 25	0.1	29.6	31.4	32.9	34.0	34.4
	0.2	42.1	44.6	46.7	48.2	48.8
	0.4	60.2	63.8	66.6	68.6	69.4
	0.8	82.5	87.9	92.3	98.2	99.2
	1.6	117.0	124.0	130.0	135.0	137.0
EVRA 32	0.1	47.4	50.2	52.6	54.4	55.0
	0.2	67.4	71.4	74.7	77.1	78.1
	0.4	96.3	102.0	107.0	110.0	111.0
	0.8	132.0	140.0	148.0	157.0	159.0
	1.6	187.0	199.0	209.0	216.0	219.0
EVRA 40	0.1	74.0	78.5	82.3	85.0	86.0
	0.2	105.0	112.0	117.0	121.0	122.0
	0.4	151.0	159.0	167.0	172.0	174.0
	0.8	206.0	222.0	231.0	246.0	248.0
	1.6	291.0	310.0	326.0	337.0	342.0

An increase in hot gas temperature t_h of 10 K, based on $t_h = t_c = 25$ °C, reduces valve capacity approx. 2% and vice versa.

A change in evaporating temperature t_e changes valve capacity; see correction factor table below.

Correction factor

When sizing valves, the table value must be multiplied by a correction factor depending on evaporating temperature t_e .

t_e °C	-40	-30	-20	-10	0	+10
R 22	0.90	0.94	0.97	1.0	1.03	1.05

Solenoid valves type EVRA and EVRAT

Capacity (continued)

R 134a

Hot gas capacity Q_h kW

Type	Pressure drop across valve Δp bar	Hot gas capacity Q_e kW				
		Evaporating temp. $t_e = -10$ °C. Hot gas temp. $t_h = t_c$ 25 °C. Subcooling $\Delta t_{sub} = 4$ K				
		Condensing temperature t_c °C				
		20	30	40	50	60
EVRA 3	0.1	0.54	0.57	0.6	0.61	0.6
	0.2	0.77	0.82	0.85	0.86	0.85
	0.4	1.1	1.2	1.2	1.2	1.2
	0.8	1.5	1.6	1.7	1.8	1.8
	1.6	2.2	2.3	2.4	2.5	2.4
EVRA/T 10	0.1	3.5	3.7	3.9	4.0	3.9
	0.2	5.0	5.3	5.5	5.6	5.6
	0.4	7.0	7.7	7.9	8.0	7.9
	0.8	9.9	10.5	11.0	11.6	11.4
	1.6	14.3	15.1	15.7	16.0	15.9
EVRA/T 15	0.1	6.4	6.7	7.0	7.1	7.1
	0.2	9.1	9.6	10.0	10.1	10.0
	0.4	12.6	13.8	14.2	14.4	14.3
	0.8	17.9	19.0	19.8	20.8	20.5
	1.6	25.7	27.2	28.2	28.8	28.6
EVRA/T 20	0.1	10.6	11.2	11.7	11.8	11.8
	0.2	15.1	16.0	16.6	16.8	16.7
	0.4	21.0	22.9	23.7	24.0	23.8
	0.8	29.8	31.6	33.0	34.7	34.2
	1.6	42.8	45.3	47.1	47.9	47.6
EVRA 25	0.1	23.6	24.9	25.9	26.4	26.2
	0.2	33.6	35.5	36.8	37.4	37.1
	0.4	46.6	51.0	52.7	53.4	52.9
	0.8	66.2	70.2	73.2	77.0	76.0
	1.6	95.2	101.0	105.0	107.0	106.0
EVRA 32	0.1	37.6	39.8	41.4	42.1	41.8
	0.2	53.8	56.8	58.9	59.8	59.4
	0.4	74.7	81.6	84.3	85.4	84.6
	0.8	106.0	112.0	117.0	123.0	122.0
	1.6	152.0	161.0	167.0	170.0	169.0
EVRA 40	0.1	58.8	62.3	64.7	65.8	65.3
	0.2	84.1	88.8	92.1	93.5	92.8
	0.4	117.0	127.0	132.0	134.0	132.0
	0.8	166.0	176.0	183.0	192.0	190.0
	1.6	238.0	252.0	262.0	266.0	265.0

An increase in hot gas temperature t_h of 10 K, based on $t_h = t_c + 25$ °C, reduces valve capacity approx. 2% and vice versa.

A change in evaporating temperature t_e changes valve capacity; see correction factor table below.

Correction factor

When sizing valves, the table value must be multiplied by a correction factor depending on evaporating temperature t_e .

t_e °C	-40	-30	-20	-10	0	10
R 134a	0.88	0.92	0.98	1.0	1.04	1.08

Solenoid valves type EVRA and EVRAT

R 404A

Capacity
(continued)

Hot gas capacity Q_h kW

Type	Pressure drop across valve Δp bar	Hot gas capacity Q_e kW				
		Evaporating temp. $t_e = -10$ °C. Hot gas temp. $t_h = t_c + 25$ °C. Subcooling $\Delta t_{sub} = 4$ K				
		Condensing temperature t_c °C				
		+20	+30	+40	+50	+60
EVRA 3	0.1	0.62	0.63	0.62	0.59	0.54
	0.2	0.87	0.89	0.88	0.83	0.76
	0.4	1.2	1.3	1.3	1.2	1.1
	0.8	1.7	1.7	1.7	1.7	1.5
	1.6	2.4	2.5	2.4	2.3	2.1
EVRA/T 10	0.1	4.0	4.1	4.0	3.8	3.5
	0.2	5.7	5.8	5.7	5.5	5.0
	0.4	8.1	8.2	8.2	7.8	7.0
	0.8	11.1	11.4	11.3	11.1	10.1
	1.6	15.7	16.0	15.8	15.2	13.9
EVRA/T 15	0.1	7.3	7.4	7.3	6.9	6.3
	0.2	10.2	10.4	10.3	9.8	8.9
	0.4	14.6	14.8	14.7	14.0	12.7
	0.8	20.1	20.4	20.3	20.0	18.1
	1.6	28.3	28.8	28.4	27.4	25.0
EVRA/T 20	0.1	12.1	12.3	12.1	11.5	10.5
	0.2	17.1	17.3	17.2	16.3	14.9
	0.4	24.4	24.7	24.5	23.3	21.1
	0.8	33.4	34.0	33.9	33.3	30.2
	1.6	47.1	48.0	47.4	45.6	41.6
EVRA 25	0.1	26.8	27.4	26.9	25.6	23.3
	0.2	37.9	38.4	38.2	36.3	33.0
	0.4	54.2	54.9	54.5	51.7	47.0
	0.8	74.2	75.6	75.3	74.0	67.2
	1.6	105.0	107.0	105.0	101.0	92.5
EVRA 32	0.1	43.0	43.8	43.0	40.9	37.3
	0.2	60.6	61.4	61.1	58.1	52.8
	0.4	86.7	87.8	87.2	82.7	75.2
	0.8	119.0	121.0	120.0	118.0	107.0
	1.6	167.0	171.0	168.0	162.0	148.0
EVRA 40	0.1	67.0	68.5	67.3	64.0	58.3
	0.2	94.8	96.0	95.5	90.8	82.5
	0.4	136.0	137.0	136.0	129.0	117.0
	0.8	186.0	189.0	188.0	185.0	168.0
	1.6	262.0	266.0	263.0	253.0	231.0

An increase in hot gas temperature t_h of 10 K, based on $t_h = t_c + 25$ °C, reduces valve capacity approx. 2% and vice versa.

A change in evaporating temperature t_e changes valve capacity; see correction factor table below.

Correction factor

When sizing valves, the table value must be multiplied by a correction factor depending on evaporating temperature t_e .

t_e °C	-40	-30	-20	-10	0	10
R 404A	0.86	0.88	0.93	1.0	1.03	1.07

Solenoid valves type EVRA and EVRAT

Capacity (continued)

Hot gas capacity G_h kg/s

Type	Hot gas temperature t_h °C	Condensing temperature t_k °C	Hot gas capacity G_h kg/s at pressure drop across valve Δp bar								
			0.5	1	2	3	4	5	6	7	8

R 717 (NH₃)

EVRA 3	90	25	0.003	0.005	0.006	0.007	0.007	0.007	0.007	0.007	0.007
		35	0.004	0.005	0.007	0.009	0.009	0.01	0.01	0.01	0.01
		45	0.005	0.006	0.009	0.01	0.011	0.012	0.013	0.013	0.013
EVRA/T 10	90	25	0.022	0.03	0.04	0.045	0.048	0.048	0.048	0.048	0.048
		35	0.026	0.036	0.048	0.056	0.061	0.064	0.065	0.065	0.065
		45	0.030	0.041	0.056	0.066	0.074	0.079	0.083	0.085	0.086
EVRA/T 15	90	25	0.040	0.054	0.072	0.081	0.086	0.087	0.087	0.087	0.087
		35	0.046	0.064	0.086	0.1	0.109	0.115	0.117	0.117	0.117
		45	0.053	0.074	0.101	0.12	0.133	0.142	0.149	0.153	0.155
EVRA/T 20	90	25	0.066	0.09	0.12	0.12	0.144	0.145	0.145	0.145	0.145
		35	0.077	0.107	0.144	0.167	0.182	0.191	0.195	0.195	0.195
		45	0.089	0.124	0.169	0.199	0.211	0.237	0.248	0.255	0.258
EVRA 25	90	25	0.143	0.197	0.26	0.296	0.313	0.316	0.316	0.316	0.316
		35	0.168	0.232	0.313	0.364	0.397	0.417	0.425	0.425	0.425
		45	0.194	0.269	0.368	0.434	0.482	0.516	1.54	0.555	0.561
EVRA 32	90	25	0.233	0.322	0.424	0.483	0.511	0.516			
		35	0.274	0.379	0.511	0.594	0.648	0.681	0.694		
		45	0.316	0.439	0.601	0.709	0.787	0.842	0.882	0.906	0.916
EVRA 40	90	25	0.362	0.503	0.663	0.755	0.798	0.806			
		35	0.429	0.592	0.798	0.929	1.013	1.064	1.084		
		45	0.495	0.686	0.939	1.107	1.23	1.316	1.378	1.416	1.431

R 22

EVRA 3	90	25	0.008	0.011	0.014	0.016	0.017	0.017	0.017	0.017	0.017
		35	0.009	0.012	0.017	0.019	0.021	0.022	0.022	0.022	0.022
		45	0.010	0.014	0.019	0.022	0.025	0.026	0.027	0.028	0.028
EVRA/T 10	90	25	0.051	0.069	0.092	0.104	0.109	0.111	0.111	0.111	0.111
		35	0.058	0.08	0.108	0.125	0.136	0.142	0.144	0.144	0.144
		45	0.066	0.092	0.125	0.146	0.162	0.172	0.179	0.183	0.183
EVRA/T 15	90	25	0.091	0.125	0.165	0.187	0.197	0.199	0.199	0.199	0.199
		35	0.105	0.144	0.194	0.225	0.244	0.256	0.258	0.258	0.258
		45	0.119	0.165	0.224	0.263	0.291	0.31	0.322	0.329	0.330
EVRA/T 20	90	25	0.152	0.208	0.275	0.311	0.328	0.332	0.332	0.332	0.332
		35	0.174	0.241	0.323	0.375	0.407	0.425	0.431	0.431	0.431
		45	0.193	0.275	0.374	0.439	0.485	0.516	0.537	0.548	0.55
EVRA 25	90	25	0.331	0.453	0.599	0.677	0.715	0.722	0.722	0.722	0.722
		35	0.38	0.524	0.704	0.816	0.886	0.925	0.938	0.938	0.938
		45	0.431	0.598	0.814	0.956	1.056	1.125	1.169	1.192	1.197
EVRA 32	90	25	0.539	0.739	0.976	1.106	1.168	1.179			
		35	0.619	0.856	1.15	1.331	1.446	1.509	1.531		
		45	0.704	0.978	1.329	1.562	1.723	1.837	1.909	1.947	1.955
EVRA 40	90	25	0.843	1.155	1.525	1.728	1.825	1.843			
		35	0.968	1.338	1.798	2.08	2.26	2.358	2.393		
		45	1.1	1.528	2.078	2.44	2.693	2.87	2.383	3.043	3.055

An increase in hot gas temperature t_h of 10 K reduces valve capacity approx. 2% and vice versa.

Solenoid valves type EVRA and EVRAT

Capacity (continued)

Hot gas capacity G_h kg/s

Type	Varmgas-temperatur t_h °C	Kondense-ringstemp. t_k °C	Varmgaskapacitet G_h kg/s ved trykfaldet i ventilen Δp bar								
			0.5	1	2	3	4	5	6	7	8

R 134a

EVRA 3	60	25	0.007	0.009	0.011	0.012	0.012					
		35	0.009	0.011	0.014	0.016	0.016	0.016	0.016			
		45	0.01	0.012	0.018	0.02	0.021	0.021	0.021	0.021	0.021	0.021
EVRA/T 10		25	0.048	0.06	0.074	0.077	0.077					
		35	0.055	0.071	0.092	0.103	0.104	0.104				
		45	0.06	0.084	0.111	0.127	0.134	0.135	0.135	0.135	0.135	0.135
EVRA/T 15		25	0.081	0.108	0.134	0.14	0.14					
		35	0.094	0.129	0.166	0.192	0.187	0.187	0.187			
		45	0.108	0.151	0.2	0.228	0.241	0.244	0.244	0.244	0.244	0.244
EVRA/T 20		25	0.134	0.18	0.223	0.233	0.233					
		35	0.157	0.215	0.276	0.307	0.312	0.312	0.312			
		45	0.181	0.252	0.333	0.381	0.403	0.407	0.407	0.407	0.407	0.407
EVRA 25	25	0.292	0.391	0.486	0.506	0.506						
	35	0.341	0.467	0.602	0.668	0.679	0.679	0.679				
	45	0.393	0.549	0.725	0.83	0.876	0.885	0.885	0.885	0.885	0.885	
EVRA 32	25	0.478	0.638	0.793	1.826	0.826						
	35	0.556	0.763	0.994	1.091	1.108	1.108	1.108				
	45	0.641	0.897	1.197	1.354	1.432	1.446	1.446	1.446	1.446	1.446	
EVRA 40	25	0.747	0.998	1.24	1.291	1.291						
	35	0.87	1.192	1.553	1.704	1.731	1.731	1.731				
	45	1.002	1.402	1.87	2.117	2.237	2.259	2.259	2.259	2.259		

R 404A

EVRA 3	60	25	0.01	0.013	0.018	0.021	0.022	0.023	0.023	0.023	0.023
		35	0.011	0.015	0.02	0.024	0.027	0.028	0.029	0.029	0.03
		45	0.012	0.017	0.023	0.028	0.032	0.034	0.035	0.036	0.037
EVRA/T 10		25	0.063	0.087	0.116	0.134	0.145	0.148	0.149	0.149	0.149
		35	0.072	0.1	0.134	0.158	0.174	0.184	0.19	0.19	0.192
		45	0.081	0.112	0.153	0.182	0.203	0.228	0.228	0.237	0.239
EVRA/T 15		25	0.113	0.157	0.21	0.242	0.26	0.267	0.269	0.269	0.269
		35	0.129	0.18	0.242	0.285	0.313	0.332	0.341	0.342	0.346
		45	0.146	0.202	0.275	0.327	0.365	0.393	0.411	0.424	0.431
EVRA/T 20		25	0.189	0.262	0.35	0.403	0.433	0.445	0.449	0.449	0.449
		35	0.215	0.3	0.404	0.474	0.521	0.552	0.569	0.57	0.576
		45	0.243	0.337	0.459	0.545	0.609	0.656	0.684	0.707	0.719
EVRA 25	25	0.411	0.57	0.763	0.878	0.942	0.969	0.978	0.978	0.978	
	35	0.468	0.653	0.881	1.032	1.136	1.203	1.239	1.241	1.253	
	45	0.529	0.734	1.0	1.188	1.326	1.43	1.49	1.539	1.566	
EVRA 32	25	0.672	0.931	1.245	1.432	1.539	1.581	1.581	1.581	1.581	
	35	0.765	1.069	1.436	1.686	1.854	1.964	2.022	2.025	2.025	
	45	0.862	1.198	1.632	1.939	1.836	2.34	2.433	2.513	2.557	
EVRA 40	25	1.05	1.454	1.946	2.238	2.406	2.471	2.471	2.471	2.471	
	35	1.195	1.657	2.245	2.635	2.897	3.068	3.161	3.166	3.166	
	45	1.348	1.873	2.55	3.03	3.384	3.65	3.801	3.926	3.995	

An increase in hot gas temperature t_h of 10 K reduces valve capacity approx. 2% and vice versa.

Solenoid valves type EVRA and EVRAT

Design Function

- 4. Coil
- 16. Armature
- 18. Valve plate / Pilot valve plate
- 20. Earth terminal
- 24. Connection for flexible steel hose
- 28. Gasket
- 29. Pilot orifice
- 30. O-ring
- 31. Piston ring
- 36. DIN plug
- 40. Terminal box
- 43. Valve cover
- 44. O-ring
- 45. Valve cover gasket
- 48. Flange gasket
- 49. Valve body
- 51. Cover / Threaded plug
- 53. Manual operation spindle
- 59. Strainer
- 73. Equalization hole
- 74. Main channel
- 75. Pilot channel
- 76. Compression spring
- 80. Diaphragm/Servo piston
- 82. Support washer
- 83. Valve seat
- 84. Main valve plate

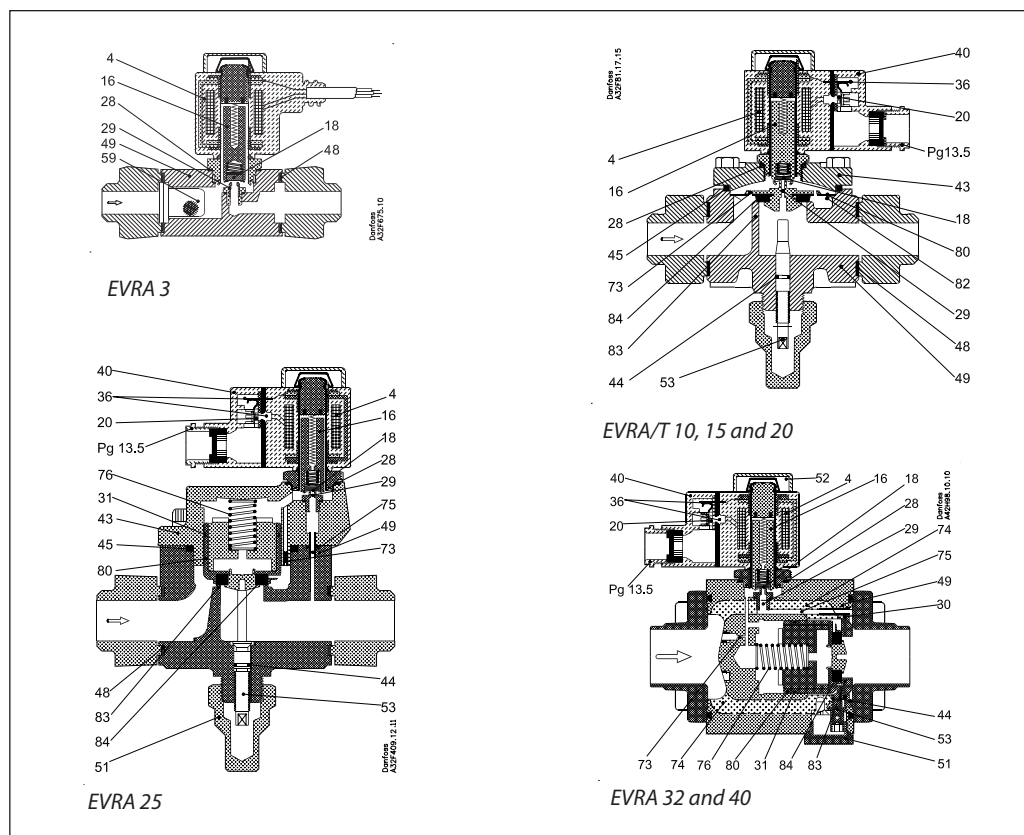

EVRA solenoid valves are designed on two different principles:

1. Direct operation
2. Servo operation

1. Direct operation

EVRA 3 is direct operated. The valve opens direct for full flow when the armature (16) moves up into the magnetic field of the coil. This means that the valve operates with a min. differential pressure of 0 bar. The teflon valve plate (18) is fitted direct on the armature (16).

Inlet pressure acts from above on the armature and the valve plate. Thus, inlet pressure, spring force and the weight of the armature act to close the valve when the coil is currentless.

2. Servo operation

EVRA/T 10 → 20 are servo operated with a "floating" diaphragm (80). The pilot orifice (29) of stainless steel is placed in the centre of the diaphragm. The teflon pilot valve plate (18) is fitted direct to the armature (16).

When the coil is currentless, the main orifice and pilot orifice are closed. The pilot orifice and main orifice are held closed by the weight of the armature, the armature spring force and the differential pressure between inlet and outlet sides.

When current is applied to the coil the armature is drawn up into the magnetic field and opens the pilot orifice. This relieves the pressure above the diaphragm, i.e. the space above the diaphragm becomes connected to the outlet side of the valve. The differential pressure between inlet and outlet sides then presses the diaphragm away from the main orifice and opens it for full flow. Therefore a certain minimum differential pressure is necessary

to open the EVRA valve and keep it open. For differential pressure 0 bar use EVRAT valves.

For EVRA 10 → 20 valves this differential pressure is 0.05 bar.

When current is switched off, the pilot orifice closes. Via the equalization holes (73) in the diaphragm, the pressure above the diaphragm then rises to the same value as the inlet pressure and the diaphragm closes the main orifice.

EVRA 25, 32 and 40 are servo operated piston valves. The valves are closed with currentless coil.

The servo piston (80) with main valve plate (84) closes against the valve seat (83) by means of the differential pressure between inlet and outlet side of the valve, the force of the compression spring (76) and possibly the piston weight.

When current to the coil is switched on, the pilot orifice (29) opens. This relieves the pressure on the piston spring side of the valve. The differential pressure will then open the valve.

The minimum differential pressure needed for full opening of the valves is 0.2 bar.



The manual opener of EVRA/EVRAT 10, 15, 20 and 25 is intended to be activated only during initial pressure testing of the refrigeration system.

After pressure testing or service-related manual forced opening of the manual opener the spindle **must** be turned fully back to back-seated position to avoid any packing gland leakage.

Furthermore it is essential that the sealing cap is properly reinstalled. This will eliminate any risk of leakage from the manual opener.

Solenoid valves type EVRA and EVRAT

Material specification

EVRA 3

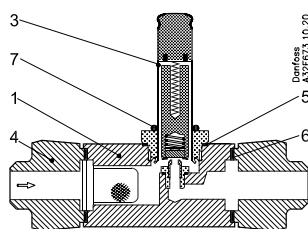

EVRA/T
10/15/20

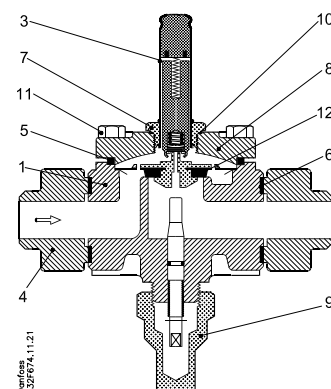

No.	Description	Solenoid valves	Material	Analysis	Mat.no.	W.no.	ISO	EN
1	Valve body	EVRA 3	Free-cutting steel	11MnPb30				10277-3
	Valve body	EVRA/T 10/15/20	Cast-iron	GJS-400-18-LT				1563
3	Armature tube	EVRA 3/10/15/20	Stainless steel	X2CrNi19-11				10088
4	Flange	EVRA/T 3/10/15/20	Steel	S235JRG2				10025
5	Gasket	EVRA 3	Aluminium	Al 99.5				10210
	Gasket	EVRA/T 10/15/20	Rubber	Cr				
6	Gasket	EVRA/T 3/10/15/20	asbestos-free					
7	Armature tube nut	EVRA/T 3/10/15/20	Stainless steel	X8CrNiS18-9				10088
8	Cover	EVRA/T 10/15/20	Cast-iron	GJS-400-18-LT				1563
9	Cover/ thread plug	EVRA/T 10/15/20	Free-cutting steel	115MnPb30				10277-3
10	Gasket	EVRA/T 10/15/20	Aluminium	Al 99.5				10210
11	Bolts	EVRA/T 10/15/20	Stainless steel	A2-70			3506	
12	Valve seat	EVRA/T 10/15/20	Teflon (PTFE)					

EVRA 25

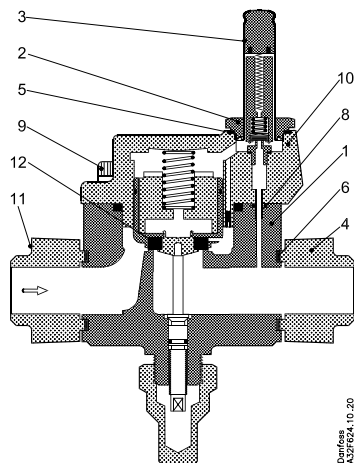

EVRA 32/40

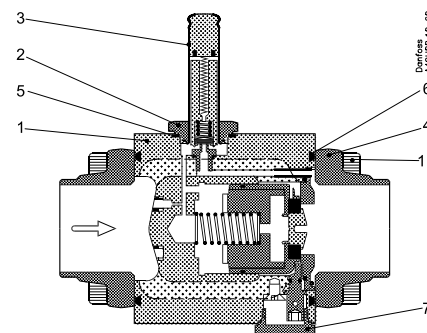

No.	Description	Solenoid valves	Material	Analysis	Mat.no.	W.no.	ISO	EN
1	Valve body	EVRA 25/32/40	Cast-iron	GJS-400-18-LT				1563
2	Armature tube nut	EVRA 25/32/40	Stainless steel	X8CrNiS 18-9				10088
3	Armature tube	EVRA 25/32/40	Stainless steel	X2CrNi19-11				10088
4	Flange	EVRA 25	Steel	S235JRG2				10025
4	Flange	EVRA 32/40	Steel	P285QH				10222-4
5	Gasket	EVRA 25/32/40	Stainless steel/NBR	X10CrNi18-8				1.4310
6	Gasket	EVRA 25	asbestos-free					
	Gasket	EVRA 32/40	Rubber	Cr				
7	Cover/thread plug	EVRA 25	Free-cutting steel	115MnPb30				10277-3
	Cover/thread plug	EVRA 32/40	Stainless steel	X5CrNi17-10				10088
8	Gasket	EVRA 25	Rubber	CR				
9	Bolts	EVRA 25	Stainless steel	A2-70			3506	
10	Cover	EVRA 25	Cast-iron	GJS-400-18-LT				1563
11	Bolts	EVRA 25/32/40	Stainless steel	A2-70			3506	
12	Valve seat	EVRA 25	Teflon (PTFE)					

Solenoid valves type EVRA and EVRAT

Dimensions and weight

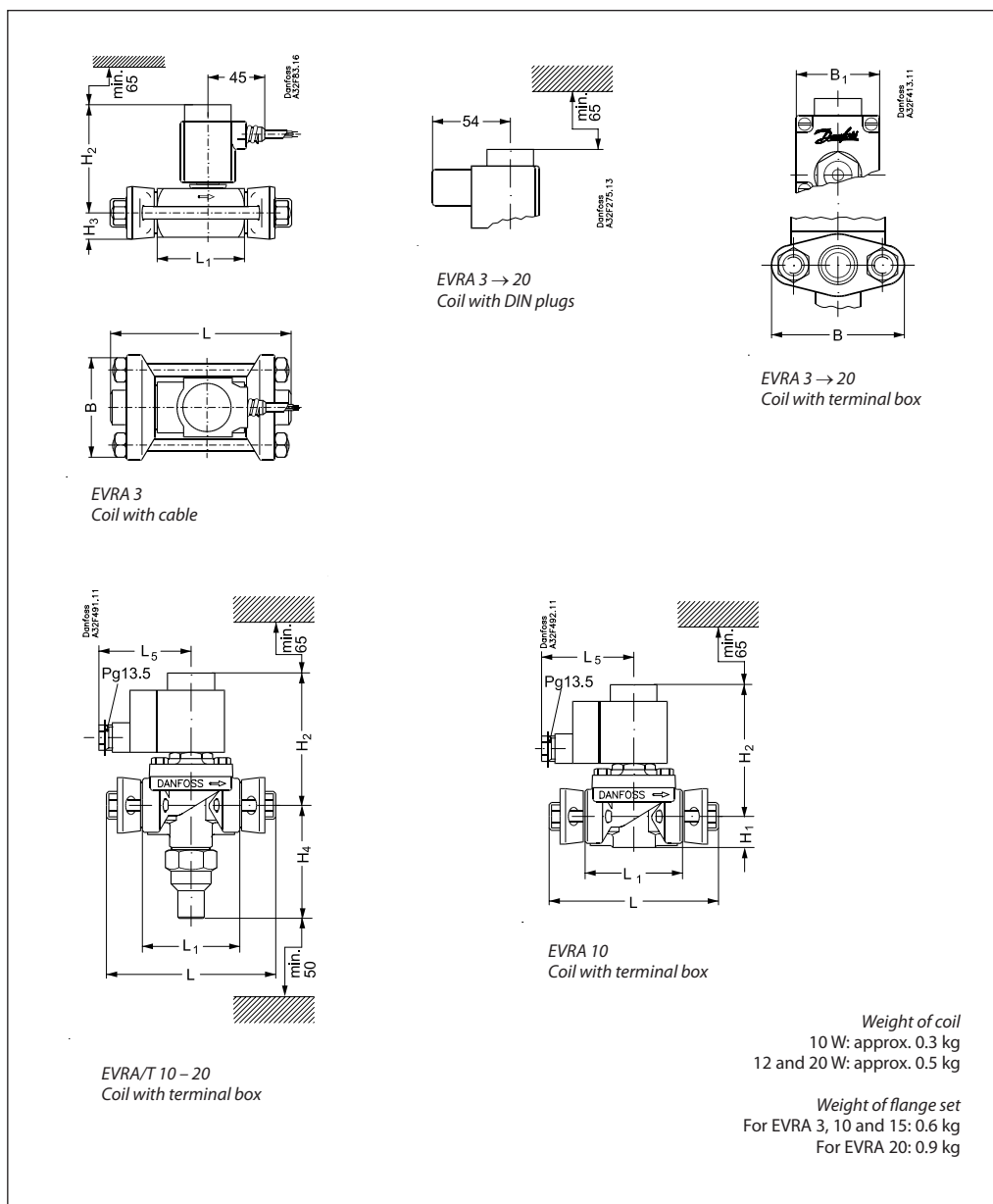

Type	H ₁	H ₂	H ₃	H ₄	L	L ₁	L ₅ max.		B	B ₁ max.	Weight ¹⁾
							10 W	12 W 20 W			
							[mm]	[mm]			
EVRA 3		84	19		124	65	75	85	80	68	1.2
EVRA/T 10	22	100		81	130	68			80	68	1.7
EVRA/T 15		100		81	130	68			80	68	1.8
EVRA/T 20		110		77	155	85			96	68	2.7

¹⁾ With coil, without flanges

Solenoid valves type EVRA and EVRAT

Dimensions and weight (continued)

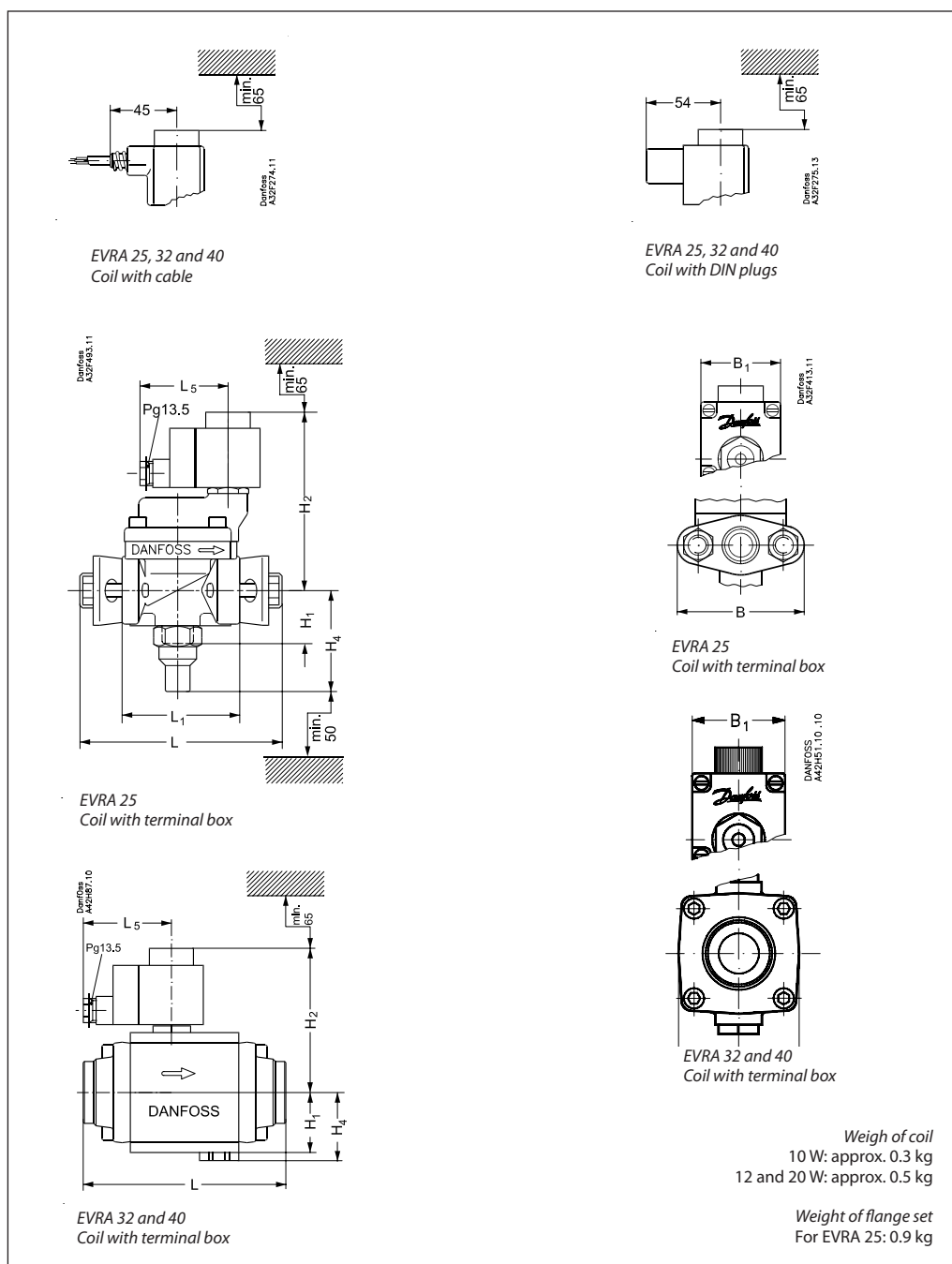

Type	H ₁	H ₂	H ₃	H ₄	L	L ₁	L ₃ max.		B	B ₁ max.	Weight ¹⁾
							10 W	12 W 20 W			
							[mm]	[mm]			
EVRA 25	46	141		78	162	92	75	85	95	68	3.0
EVRA 32	47	115		53	175				80	68	4.0
EVRA 40	47	115		53	175				80	68	4.0

¹⁾ With coil, without flanges

Stainless steel solenoid valves

Type EVRS 3-20 and EVRST 10-20

Contents

	Page
Features	75
Technical data	75
Ordering	76
Capacity	77
Design / function	83
Material specification	84
Dimensions and weights	85

Stainless steel solenoid valves

Type EVRS 3-20 and EVRST 10-20



EVRS and EVRST are valves made of stainless steel.

- EVRS 3 is direct operated.
- EVRS 10, 15 and 20 are servo operated.
- EVRST 10,15 and 20 are forced servo operated.

The valves are used in liquid, suction, hot gas and oil return lines with ammonia or fluorinated refrigerants.

EVRS 3 and EVRST are designed for keeping open at a pressure drop of 0 bar.

EVRS / EVRST 10, 15 and 20 are equipped with spindle for manual opening.

EVRS and EVRST are supplied as components, i.e. valve body and coil must be separately ordered.

Features

- Stainless steel valve body and connections
- Max. working pressure 50 barg
- Applicable to HCFC, HFC, R717 (Ammonia) and R744 (CO₂).
- MOPD up to 38 bar with 20 watt AC coil
- Wide choice of AC and DC coils
- Designed for temperatures of media up to 105 °C
- Manual stem on EVRS and EVRST 10, EVRST 15 and EVRST 20
- Classification: DNV, CRN, BV, EAC etc.
To get an updated list of certification on the products please contact your local Danfoss Sales Company.

Approvals

The Low Voltage Directive (LVD) 73/23/EC with amendments EN 60730-2-8

Technical data

Refrigerants

Applicable to HCFC, HFC, R717 (Ammonia) and R744 (CO₂).

Temperature of medium

-40 – 105 °C for 10 or 12 watt coil. Max. 130 °C during defrosting.

-40 – 80 °C for 20 watt coil.

Stainless steel solenoid valves, type EVRS 3-20 and EVRST 10-20

Technical data (Continued)

Ambient temperature and enclosure for coil: See "Coils for solenoid valves", lit.no. AI237186440089

Type	Opening differential pressure Δp bar					k_v value ²⁾ [m ³ /h]	Max. working pressure Ps
	Max. (MOPD) liquid ¹⁾						
	Min.	10 W AC	12 W AC	20 W AC	20 W DC		
EVRS 3	0.0	21	25	38	14	0.23	50 barg
EVRS 10	0.05	21	25	38	18	1.5	
EVRST 10	0.0	14	21	38	16	1.5	
EVRS 15	0.05	21	25	38	18	2.7	
EVRST 15	0.0	14	21	38	18	2.7	
EVRS 20	0.05	21	25	38	13	4.5	
EVRST 20	0.0	14	21	38	13	4.5	

¹⁾ MOPD for media in gas form is approx. 1 bar greater.

²⁾ The k_v value is the water flow in m³/h at a pressure drop in the valve of 1 bar, $\rho = 1000$ kg/m³.

Type	Rated capacity ¹⁾ kW														
	Liquid					Suction vapour					Hot gas				
	R717	R22	R134a	R404A	R410A	R717	R22	R134a	R404A	R410A	R717	R22	R134a	R404A	R410A
EVRS 3	21.8	4.6	4.3	3.2	4.5						6.5	2.1	1.7	1.7	2.3
EVRS / EVRST 10	142.0	30.2	27.8	21.1	29.7	9.0	3.4	2.5	3.1	4.3	42.6	13.9	11.0	11.3	14.9
EVRS / EVRST 15	256.0	54.4	50.1	38.0	53.5	16.1	6.2	4.4	5.5	7.7	76.7	24.9	19.8	20.3	26.7
EVRS / EVRST 20	426.0	90.6	83.5	63.3	89.1	26.9	10.3	7.3	9.2	12.0	128.0	41.5	32.9	33.9	44.5

¹⁾ Rated liquid and suction vapour capacity is based on evaporating temperature $t_e = -10$ °C, liquid temperature ahead of valve $t_l = 25$ °C, and pressure drop across valve $\Delta p = 0.15$ bar.

Rated hot gas capacity is based on condensing temperature $t_c = 40$ °C, pressure drop across valve $\Delta p = 0.8$ bar, hot gas temperature $t_h = 60$ °C, and subcooling of refrigerant $\Delta t_{sub} = 4$ K.

Type	R 744 Rated capacity kW ²⁾	
	Liquid	Suction
EVRS 3	6.65	-
EVRS / EVRST 10	43.3	6.9
EVRS / EVRST 15	78.0	12.4
EVRS / EVRST 20	130.0	20.7

²⁾ Rated liquid and suction vapour capacity is based on evaporating temperature $t_e = -40$ °C, liquid temperature ahead of the valve $t_l = -8$ °C and pressure drop across the valve $\Delta p = 0.15$ bar
For other condition please refer to DIR-Calc or contact your local Danfoss office.

Ordering

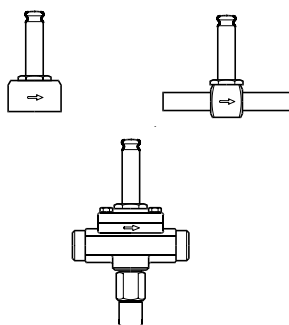

Separate valve bodies

Type	Max. working pressure Ps [barg]	Connection		Code no.	
		Weld [in]	Pipe thread ISO 228/1	With manual stem	Without manual stem
EVRS 3	50	$\frac{3}{8}$			032F3080
EVRS 3	50		G $\frac{1}{4}$		032F3081
EVRS 10	50	$\frac{1}{2}$		032F3082	
EVRST 10	50	$\frac{1}{2}$		032F3083	
EVRS 15	50	$\frac{3}{4}$		032F3084	
EVRST 15	50	$\frac{3}{4}$		032F3085	
EVRS 20	50	1		032F5437	
EVRST 20	50	1		032F5438	

Coils See "Coils for solenoid valves", lit.no. AI237186440089

Stainless steel solenoid valves, type EVRS 3-20 and EVRST 10-20

Capacity

Liquid capacity Q_l kW

Type	Liquid capacity Q_l kW at pressure drop across valve Δp bar				
	0.1	0.2	0.3	0.4	0.5

R717 (NH₃)

EVRS 3	17.8	25.1	30.8	35.6	39.8
EVRS / EVRST 10	116.0	164.0	201.0	232.0	259.0
EVRS / EVRST 15	209.0	295.0	362.0	418.0	467.0
EVRS / EVRST 20	348.0	492.0	603.0	696.0	778.0

R22

EVRS 3	3.8	5.3	6.6	7.6	8.5
EVRS / EVRST 10	24.7	34.9	42.7	49.3	55.1
EVRS / EVRST 15	44.4	62.8	76.9	88.8	99.2
EVRS / EVRST 20	73.9	105.0	128.0	148.0	165.0

R134a

EVRS 3	3.5	4.9	6.0	7.0	7.8
EVRS / EVRST 10	22.7	32.2	39.4	45.5	50.8
EVRS / EVRST 15	40.9	57.9	70.9	81.8	91.5
EVRS / EVRST 20	68.2	96.5	118.0	136.0	153.0

R404A

EVRS 3	2.6	3.7	4.6	5.3	5.9
EVRS / EVRST 10	17.2	24.3	29.8	34.4	38.5
EVRS / EVRST 15	31.0	43.8	53.7	62.0	69.3
EVRS / EVRST 20	51.7	73.0	89.5	103.0	116.0

R410A

EVRS 3	3.7	5.3	6.4	7.5	8.3
EVRS / EVRST 10	24.3	34.4	42.0	48.6	54.3
EVRS / EVRST 15	43.7	61.8	75.6	87.5	97.7
EVRS / EVRST 20	72.9	103.0	126.0	146.0	163.0

Capacities are based on liquid temperature $t_l = 5$ °C ahead of valve, evaporating temperature $t_e = -10$ °C, and superheat 0 K.

Correction factors

When sizing valves, the plant capacity must be multiplied by a correction factor depending on liquid temperature t_l ahead of valve / evaporator.

When the corrected capacity is known, the selection can be made from the table.

t_v °C	-10	0	10	20	25	30	40	50
R717 (NH ₃)	0.84	0.88	0.92	0.97	1.0	1.03	1.09	1.16
R22, R134a	0.76	0.81	0.88	0.96	1.0	1.05	1.16	1.31
R404A	0.70	0.76	0.84	0.94	1.0	1.07	1.24	1.47
R410A	0.73	0.79	0.86	0.95	1.0	1.06	1.23	1.47

Stainless steel solenoid valves, type EVRS 3-20 and EVRST 10-20

Capacity (continued)

Suction vapour capacity Q_e kW

Type	Pressure drop across valve Δp bar	Suction vapour capacity Q_e kW at evaporating temperature t_e °C					
		-40	-30	-20	-10	0	10

R717 (NH₃)

EVRS / EVRST 10	0.1	3.4	4.5	5.9	7.3	8.9	10.6
	0.15	4.0	5.4	7.0	9.0	10.9	13.0
	0.2	4.5	6.1	7.9	10.0	12.6	15.0
EVRS / EVRST 15	0.1	6.1	8.1	10.7	13.2	16.0	19.1
	0.15	7.2	9.7	12.5	16.1	19.6	23.4
	0.2	8.0	11.0	14.2	18.0	22.6	27.0
EVRS / EVRST 20	0.1	10.2	13.5	17.8	21.9	26.6	31.9
	0.15	12.1	16.1	20.9	26.9	32.6	39.0
	0.2	13.4	18.3	23.7	29.9	37.7	45.1

R22

EVRS / EVRST 10	0.1	1.4	1.8	2.3	2.8	3.4	4.0
	0.15	1.6	2.1	2.7	3.4	4.1	4.9
	0.2	1.8	2.4	3.1	3.8	4.8	5.6
EVRS / EVRST 15	0.1	2.5	3.2	4.1	5.0	6.1	7.2
	0.15	2.9	3.8	4.8	6.2	7.4	8.8
	0.2	3.3	4.3	5.5	6.8	8.6	10.2
EVRS / EVRST 20	0.1	4.1	5.3	6.8	8.4	10.1	12.0
	0.15	4.9	6.4	8.1	10.3	12.3	14.7
	0.2	5.5	7.2	9.2	11.4	14.3	16.9

R134a

EVRS / EVRST 10	0.1	0.87	1.2	1.6	2.1	2.6	3.2
	0.15	0.99	1.4	1.9	2.4	3.2	3.9
	0.2	1.1	1.6	2.1	2.8	3.5	4.5
EVRS / EVRST 15	0.1	1.6	2.1	2.8	3.8	4.7	5.7
	0.15	1.8	2.5	3.4	4.4	5.7	7.0
	0.2	2.0	2.8	3.8	5.0	6.3	8.1
EVRS / EVRST 20	0.1	2.6	3.6	4.7	6.3	7.8	9.6
	0.15	3.0	4.2	5.6	7.3	9.5	11.7
	0.2	3.3	4.7	6.4	8.3	10.5	13.5

R404A

EVRS / EVRST 10	0.1	1.2	1.5	2.0	2.5	3.1	3.7
	0.15	1.4	1.8	2.4	3.1	3.8	4.6
	0.2	1.6	2.1	2.7	3.4	4.3	5.3
EVRS / EVRST 15	0.1	2.1	2.7	3.6	4.5	5.5	6.6
	0.15	2.5	3.3	4.3	5.5	6.8	8.2
	0.2	2.8	3.7	4.9	6.1	7.8	9.5
EVRS / EVRST 20	0.1	3.5	4.6	6.0	7.5	9.2	11.1
	0.15	4.1	5.5	7.1	9.2	11.3	13.6
	0.2	4.6	6.2	8.1	10.2	13.0	15.8

R410A

EVRS / EVRST 10	0.1	1.9	2.3	2.9	3.5	4.2	5.0
	0.15	2.2	2.9	3.5	4.3	5.1	6.1
	0.2	2.6	3.3	4.0	5.0	5.9	7.0
EVRS / EVRST 15	0.1	3.3	4.2	5.2	6.3	7.6	9.0
	0.15	4.0	5.1	6.3	7.7	9.2	11.0
	0.2	4.7	5.9	7.3	8.9	10.7	12.7
EVRS / EVRST 20	0.1	5.6	7.0	8.6	10.5	12.6	15.0
	0.15	6.7	8.6	10.5	12.9	15.4	18.4
	0.2	7.8	9.9	12.2	14.9	17.8	21.2

Capacities are based on liquid temperature $t_l = 25$ °C ahead of evaporator.
The table values refer to the evaporator capacity and are given as a function of evaporating temperature t_e and pressure drop Δp in valve.
Capacities are based on dry, saturated vapour ahead of valve.
During operation with superheated vapour ahead of valve, the capacities are reduced by 4% for each 10 K superheat.

Correction factors

When sizing valves, the evaporator capacity must be multiplied by a correction factor depending on liquid temperature t_l ahead of expansion valve.

When the corrected capacity is known, the selection can be made from the table.

t_l °C	-10	0	10	20	25	30	40	50
R717 (NH ₃)	0.84	0.88	0.92	0.97	1.0	1.03	1.09	1.16
R22, R134a	0.76	0.81	0.88	0.96	1.0	1.05	1.16	1.31
R404A	0.70	0.76	0.84	0.94	1.0	1.07	1.24	1.47
R410A	0.76	0.80	0.89	0.96	1.0	1.05	1.18	1.37

Stainless steel solenoid valves, type EVRS 3-20 and EVRST 10-20

Capacity (continued)

Hot gas capacity Q_g kW

Type	Pressure drop across valve Δp bar	Hot gas capacity Q_g kW				
		Evaporating temp. $t_e = -10$ °C. Hot gas temp. $t_h = t_c$ 25 °C. Subcooling $\Delta t_{sub} = 4$ K				
		Condensing temperature t_c °C				
		20	30	40	50	60

R717 (NH₃)

EVRS 3	0.1	1.8	2.1	2.3	2.5	2.6
	0.2	2.6	2.9	3.2	3.5	3.7
	0.4	3.8	4.2	4.6	4.9	5.3
	0.8	5.1	6.0	6.5	7.1	7.6
	1.6	7.4	8.3	9.1	9.9	10.9
EVRS / EVRST 10	0.1	12.0	3.4	14.7	16.0	17.2
	0.2	17.1	19.0	20.9	22.7	24.4
	0.4	24.5	27.1	29.7	32.2	34.7
	0.8	34.0	39.0	42.6	46.1	49.5
	1.6	48.5	53.8	59.1	64.3	1.3
EVRS / EVRST 15	0.1	21.7	24.1	26.4	28.8	31.0
	0.2	30.8	34.2	37.5	40.8	44.0
	0.4	44.1	48.8	53.5	58.0	62.4
	0.8	61.2	70.3	76.7	83.0	89.1
	1.6	87.4	96.9	106.0	116.0	128.0
EVRS / EVRST 20	0.1	36.1	40.1	44.0	48.0	51.7
	0.2	51.4	57.0	62.6	68.0	73.2
	0.4	73.5	81.3	89.1	96.7	104.0
	0.8	102.0	117.0	128.0	138.0	148.0
	1.6	146.0	161.0	177.0	193.0	214.0

R22

EVRS 3	0.1	0.68	0.72	0.76	0.78	0.79
	0.2		1.0	1.1	1.1	1.1
	0.4	0.97	1.5	1.5	1.6	1.6
	0.8	1.4	2.0	2.1	2.3	2.3
	1.6	1.9	2.9	3.0	3.1	3.2
EVRS / EVRST 10	0.1	4.4	4.7	4.9	5.1	5.2
	0.2	6.3	6.7	7.0	7.2	7.3
	0.4	9.0	9.6	10.0	10.3	10.4
	0.8	12.4	13.2	13.9	14.7	14.9
	1.6	17.5	18.6	19.6	20.2	20.5
EVRS / EVRST 15	0.1	8.0	8.5	8.9	9.2	9.3
	0.2	11.4	12.1	12.6	13.0	13.2
	0.4	16.3	17.2	18.0	18.5	18.7
	0.8	22.3	23.1	24.9	26.5	26.8
	1.6	31.5	33.5	35.2	36.4	36.9
EVRS / EVRST 20	0.1	13.3	14.1	14.8	15.3	15.5
	0.2	19.0	20.1	21.0	21.7	22.0
	0.4	27.1	28.7	30.0	30.9	31.2
	0.8	37.1	38.4	44.5	44.2	44.6
	1.6	52.5	55.9	58.6	60.6	61.5

An increase in hot gas temperature t_h of 10 K reduces valve capacity approx. 2% and vice versa.

A change in evaporating temperature t_e changes valve capacity; see correction factor table below.

Correction factors

When sizing valves, the table value must be multiplied by a correction factor depending on evaporating temperature t_e .

t_e °C	-40	-30	-20	-10	0	10
R717 (NH ₃)	0.89	0.91	0.96	1.0	1.06	1.10
R22	0.90	0.94	0.97	1.0	1.03	1.05

Stainless steel solenoid valves, type EVRS 3-20 and EVRST 10-20

Capacity (continued)

Hot gas capacity Q_h kW

Type	Pressure drop across valve Δp bar	Hot gas capacity Q_h kW				
		Evaporating temp. $t_e = -10$ °C. Hot gas temp. $t_h = t_c + 25$ °C. Subcooling $\Delta t_{sub} = 4$ K				
		Condensing temperature t_c °C				
		20	30	40	50	60

R134a

EVRS 3	0.1	0.54	0.57	0.6	0.61	0.6
	0.2	0.77	0.82	0.85	0.86	0.85
	0.4	1.1	1.2	1.2	1.2	1.2
	0.8	1.5	1.6	1.7	1.8	1.8
	1.6	2.2	2.3	2.4	2.5	2.4
EVRS / EVRST 10	0.1	3.5	3.7	3.9	4.0	3.9
	0.2	5.0	5.3	5.5	5.6	5.6
	0.4	7.0	7.7	7.9	8.0	7.9
	0.8	9.9	10.5	11.0	11.6	11.4
	1.6	14.3	15.1	15.7	16.0	15.9
EVRS / EVRST 15	0.1	6.4	6.7	7.0	7.1	7.1
	0.2	9.1	9.6	10.0	10.1	10.0
	0.4	12.6	13.8	14.2	14.4	14.3
	0.8	17.9	19.0	19.8	20.8	20.5
	1.6	25.7	27.2	28.2	28.8	28.6
EVRS / EVRST 20	0.1	10.6	11.2	11.7	11.8	11.8
	0.2	15.1	16.0	16.6	16.8	16.7
	0.4	21.0	22.9	23.7	24.0	23.8
	0.8	29.8	31.6	33.0	34.7	34.2
	1.6	42.8	45.3	47.1	47.9	47.6

R404A

EVRS 3	0.1	0.62	0.63	0.62	0.59	0.54
	0.2	0.87	0.89	0.88	0.83	0.76
	0.4	1.2	1.3	1.3	1.2	1.1
	0.8	1.7	1.7	1.7	1.7	1.5
	1.6	2.4	2.5	2.4	2.3	2.1
EVRS / EVRST 10	0.1	4.0	4.1	4.0	3.8	3.5
	0.2	5.7	5.8	5.7	5.5	5.0
	0.4	8.1	8.2	8.2	7.8	7.0
	0.8	11.1	11.4	11.3	11.1	10.1
	1.6	15.7	16.0	15.8	15.2	13.9
EVRS / EVRST 15	0.1	7.3	7.4	7.3	6.9	6.3
	0.2	10.2	10.4	10.3	9.8	8.9
	0.4	14.6	14.8	14.7	14.0	12.7
	0.8	20.1	20.4	20.3	20.0	18.1
	1.6	28.3	28.8	28.4	27.4	25.0
EVRS / EVRST 20	0.1	12.1	12.3	12.1	11.5	10.5
	0.2	17.1	17.3	17.2	16.3	14.9
	0.4	24.4	24.7	24.5	23.3	21.1
	0.8	33.4	34.0	33.9	33.3	30.2
	1.6	47.1	48.0	47.4	45.6	41.6

An increase in hot gas temperature t_h of 10 K reduces valve capacity approx. 2% and vice versa.

A change in evaporating temperature t_e changes valve capacity; see correction factor table below.

Correction factors

When sizing valves, the table value must be multiplied by a correction factor depending on evaporating temperature t_e .

t_e °C	-40	-30	-20	-10	0	10
R404A	0.86	0.88	0.93	1.0	1.03	1.07
R134a	0.88	0.92	0.98	1.0	1.04	1.08

Stainless steel solenoid valves, type EVRS 3-20 and EVRST 10-20

Capacity (continued)

Hot gas capacity Q_h kW

Type	Pressure drop across valve Δp bar	Hot gas capacity Q_h kW				
		Evaporating temp. $t_e = -10$ °C. Hot gas temp. $t_h = t_c = 25$ °C. Subcooling $\Delta t_{sub} = 4$ K				
		Condensing temperature t_c °C				
		20	30	40	50	60

R410A

EVRS 3	0.1	0.8	0.8	0.8	0.8	0.7
	0.2	1.1	1.1	1.1	1.1	1.0
	0.4	1.6	1.6	1.6	1.6	1.5
	0.8	2.2	2.7	2.2	2.2	2.1
	1.6	3.1	3.2	3.2	3.2	2.9
EVRS / EVRST 10	0.1	5.1	5.2	5.3	5.2	4.8
	0.2	7.2	7.4	7.4	7.3	6.8
	0.4	10.2	10.4	10.5	10.3	9.6
	0.8	14.4	14.8	14.9	14.5	13.7
	1.6	20.3	20.8	21.0	20.5	19.1
EVRS / EVRST 15	0.1	9.2	9.4	9.4	9.3	8.6
	0.2	13.0	13.3	13.3	13.1	12.2
	0.4	18.4	18.8	18.9	18.5	17.2
	0.8	25.9	26.6	26.7	26.1	24.6
	1.6	36.6	37.5	37.8	36.9	34.5
EVRS / EVRST 20	0.1	15.3	15.7	15.8	15.5	14.4
	0.2	21.6	22.1	22.2	21.8	20.3
	0.4	30.6	31.3	31.5	30.8	28.7
	0.8	43.2	44.3	44.6	43.5	41.0
	1.6	61.0	62.6	63.0	61.6	57.4

An increase in hot gas temperature t_h of 10 K reduces valve capacity approx. 2% and vice versa.

A change in evaporating temperature t_e changes valve capacity; see correction factor table below.

Correction factors

When sizing valves, the table value must be multiplied by a correction factor depending on evaporating temperature t_e .

t_e °C	-40	-30	-20	-10	0	10
R410A	0.92	0.95	0.98	1.0	1.02	1.03

Stainless steel solenoid valves, type EVRS 3-20 and EVRST 10-20
**Capacity
(continued)**
Hot gas capacity G_h kg/s

Type	Hot gas temperature t_h °C	Condensing temperature t_c °C	Hot gas capacity G_h kg/s at pressure drop across valve Δp bar							
			0.5	1	2	3	4	5	6	7

R717 (NH₃)

EVRS 3	90	25	0.003	0.005	0.006	0.007	0.007	0.007	0.007	0.007	0.007	0.007
		35	0.004	0.005	0.007	0.009	0.009	0.01	0.01	0.01	0.01	0.01
		45	0.005	0.006	0.009	0.01	0.011	0.012	0.013	0.013	0.013	0.013
EVRS / EVRST 10		25	0.022	0.03	0.04	0.045	0.048	0.048	0.048	0.048	0.048	0.048
		35	0.026	0.036	0.048	0.056	0.061	0.064	0.065	0.065	0.065	0.065
		45	0.030	0.041	0.056	0.066	0.074	0.079	0.083	0.085	0.086	0.086
EVRS / EVRST 15		25	0.040	0.054	0.072	0.081	0.086	0.087	0.087	0.087	0.087	0.087
		35	0.046	0.064	0.086	0.100	0.109	0.115	0.117	0.117	0.117	0.117
		45	0.053	0.074	0.101	0.120	0.133	0.142	0.149	0.153	0.155	0.155
EVRS / EVRST 20	25	0.066	0.090	0.120	0.120	0.144	0.145	0.145	0.145	0.145	0.145	
	35	0.077	0.107	0.144	0.167	0.182	0.191	0.195	0.195	0.195	0.195	
	45	0.089	0.124	0.169	0.199	0.211	0.237	0.248	0.255	0.258	0.258	

R22

EVRS 3	90	25	0.008	0.011	0.014	0.016	0.017	0.017	0.017	0.017	0.017	0.017
		35	0.009	0.012	0.017	0.019	0.021	0.022	0.022	0.022	0.022	0.022
		45	0.010	0.014	0.019	0.022	0.025	0.026	0.027	0.028	0.028	0.028
EVRS / EVRST 10		25	0.051	0.069	0.092	0.104	0.109	0.111	0.111	0.111	0.111	0.111
		35	0.058	0.08	0.108	0.125	0.136	0.142	0.144	0.144	0.144	0.144
		45	0.066	0.092	0.125	0.146	0.162	0.172	0.179	0.183	0.183	0.183
EVRS / EVRST 15		25	0.091	0.125	0.165	0.187	0.197	0.199	0.199	0.199	0.199	0.199
		35	0.105	0.144	0.194	0.225	0.244	0.256	0.258	0.258	0.258	0.258
		45	0.119	0.165	0.224	0.263	0.291	0.31	0.322	0.329	0.330	0.330
EVRS / EVRST 20	25	0.152	0.208	0.275	0.311	0.328	0.332	0.332	0.332	0.332	0.332	
	35	0.174	0.241	0.323	0.375	0.407	0.425	0.431	0.431	0.431	0.431	
	45	0.193	0.275	0.374	0.439	0.485	0.516	0.537	0.548	0.550	0.550	

R134a

EVRS 3	60	25	0.007	0.009	0.011	0.012	0.012					
		35	0.009	0.011	0.014	0.016	0.016	0.016	0.016			
		45	0.01	0.012	0.018	0.02	0.021	0.021	0.021	0.021	0.021	0.021
EVRS / EVRST 10		25	0.048	0.06	0.074	0.077	0.077					
		35	0.055	0.071	0.092	0.103	0.104	0.104				
		45	0.06	0.084	0.111	0.127	0.134	0.135	0.135	0.135	0.135	0.135
EVRS / EVRST 15		25	0.081	0.108	0.134	0.14	0.14					
		35	0.094	0.129	0.166	0.192	0.187	0.187	0.187			
		45	0.108	0.151	0.2	0.228	0.241	0.244	0.244	0.244	0.244	0.244
EVRS / EVRST 20	25	0.134	0.180	0.223	0.233	0.233						
	35	0.157	0.215	0.276	0.307	0.312	0.312	0.312				
	45	0.181	0.252	0.333	0.381	0.403	0.407	0.407	0.407	0.407	0.407	

R404A

EVRS 3	60	25	0.01	0.013	0.018	0.021	0.022	0.023	0.023	0.023	0.023	0.023
		35	0.011	0.015	0.02	0.024	0.027	0.028	0.029	0.029	0.029	0.03
		45	0.012	0.017	0.023	0.028	0.032	0.034	0.035	0.036	0.037	0.037
EVRS / EVRST 10		25	0.063	0.087	0.116	0.134	0.145	0.148	0.149	0.149	0.149	0.149
		35	0.072	0.1	0.134	0.158	0.174	0.184	0.19	0.19	0.192	0.192
		45	0.081	0.112	0.153	0.182	0.203	0.228	0.228	0.237	0.239	0.239
EVRS / EVRST 15		25	0.113	0.157	0.21	0.242	0.26	0.267	0.269	0.269	0.269	0.269
		35	0.129	0.18	0.242	0.285	0.313	0.332	0.341	0.342	0.342	0.346
		45	0.146	0.202	0.275	0.327	0.365	0.393	0.411	0.424	0.431	0.431
EVRS / EVRST 20	25	0.189	0.262	0.350	0.403	0.433	0.445	0.449	0.449	0.449	0.449	
	35	0.215	0.300	0.404	0.474	0.521	0.552	0.569	0.570	0.576	0.576	
	45	0.243	0.337	0.459	0.545	0.609	0.656	0.684	0.707	0.719	0.719	

R410A

EVRS 3	90	25	0.009	0.013	0.018	0.022	0.025	0.028	0.031	0.031	0.031	0.031
		35	0.010	0.014	0.020	0.025	0.029	0.032	0.035	0.038	0.038	0.038
		45	0.012	0.016	0.023	0.029	0.033	0.037	0.040	0.044	0.044	0.047
EVRS / EVRST 10		25	0.059	0.083	0.117	0.144	0.166	0.185	0.201	0.201	0.201	0.201
		35	0.067	0.094	0.133	0.163	0.189	0.211	0.231	0.249	0.249	0.249
		45	0.076	0.108	0.152	0.186	0.215	0.241	0.263	0.285	0.304	0.304
EVRS / EVRST 15		25	0.106	0.150	0.211	0.259	0.300	0.334	0.361	0.361	0.361	0.361
		35	0.120	0.170	0.240	0.294	0.340	0.380	0.416	0.449	0.449	0.449
		45	0.137	0.194	0.274	0.335	0.387	0.433	0.474	0.513	0.548	0.548
EVRS / EVRST 20	25	0.177	0.149	0.352	0.431	0.498	0.556	0.602	0.602	0.602	0.602	
	35	0.200	0.283	0.400	0.490	0.566	0.633	0.693	0.748	0.748	0.748	
	45	0.228	0.323	0.456	0.558	0.645	0.722	0.790	0.854	0.913	0.913	

An increase in hot gas temperature t_h of 10 K reduces valve capacity approx. 2% and vice versa.

Design / function

- 4. Coil
- 16. Armature
- 18. Pilot valve plate
- 20. Earth terminal
- 24. Connection for flexible steel hose
- 28. Gasket
- 29. Pilot orifice
- 36. DIN plug
- 40. Terminal box
- 43. Valve cover
- 44. O-ring
- 45. Valve cover gasket
- 49. Valve body
- 51. Cover
- 53. Manual operating spindle
- 73. Equalization hole
- 80. Diaphragm
- 82. Support washer
- 83. Valve seat
- 84. Main valve plate

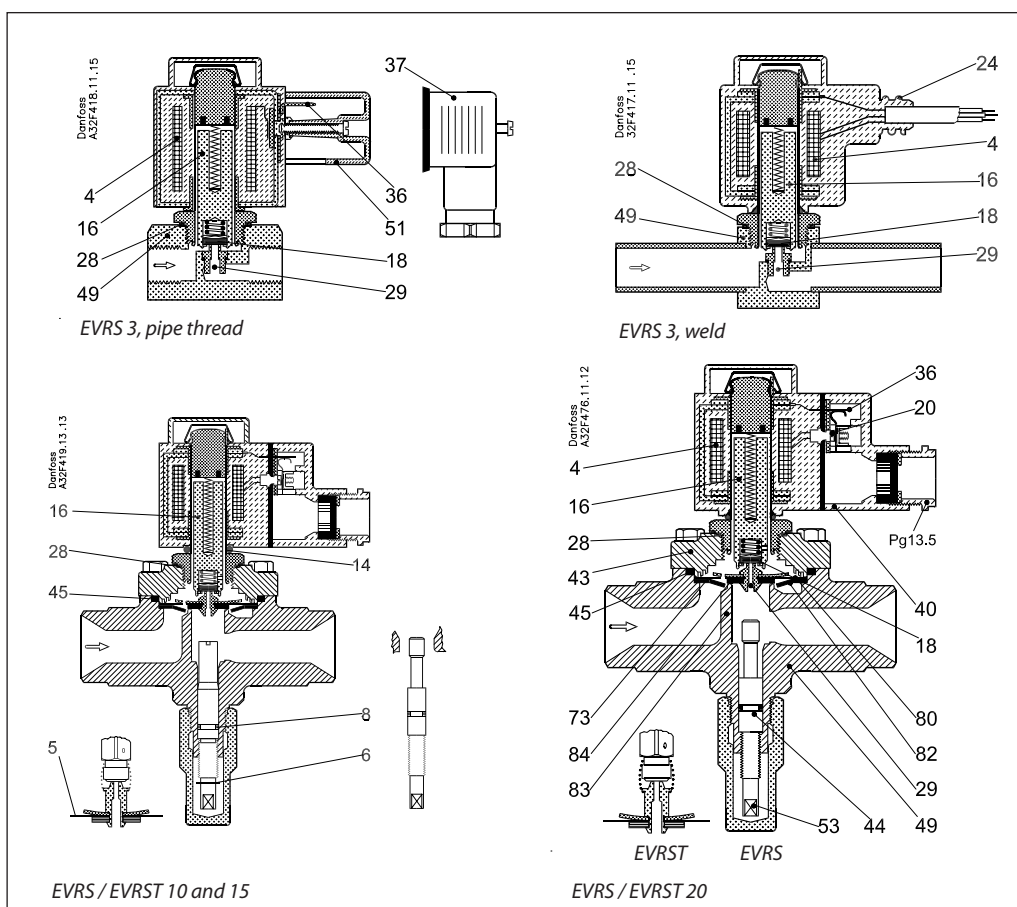

The solenoid valve design is based on three different principles:

1. Direct operation
2. Servo operation
3. Forced servo operation

1. Direct operation

EVRS 3 is directly operated. The valve opens direct for full flow when the armature (16) moves up into the magnetic field of the coil. This means that the valve operates with a min. differential pressure of 0 bar. The valve plate (18) made of teflon and is fitted direct to the armature (16).

Inlet pressure acts from above on the armature and with it the valve plate. Thus, inlet pressure, spring force and the weight of the armature act to close the valve when the coil is currentless.

2. Servo operation

EVRS 10, 15 and 20 are servo operated with a "floating" diaphragm (80). The pilot orifice (29), which is of stainless steel, is placed in the centre of the diaphragm.

The teflon pilot valve plate (18) is fitted direct to the armature (16).

With the coil currentless, the main orifice and pilot orifice are closed.

The pilot orifice and main orifice are held closed by the weight of the armature, the armature spring force and the differential pressure between inlet and outlet sides.

When current is applied to the coil the armature

is drawn up into the magnetic field and opens the pilot orifice. This relieves the pressure above the diaphragm because the space above the diaphragm becomes connected to the outlet side of the valve. The differential pressure between inlet and outlet sides then presses the diaphragm away from the main orifice which opens to full flow.

Thus a certain minimum differential pressure is necessary to open the valve and keep it open. For EVRS 10, 15 and 20 valves this differential pressure is 0.05 bar.

When current is switched off, the pilot orifice closes. Then the pressure above the diaphragm rises, via the equalization holes (73) in the diaphragm, to the inlet pressure and causes the diaphragm to close the main orifice.

3. Forced servo operation

EVRST 10, 15 and 20 are forced servo operated solenoid valves.

Forced servo operation differs from servo operation in that in a forced servo operated valve the armature and the diaphragm are connected by a spring. Thus the armature helps to lift the diaphragm (80) and keep it lifted so that the pressure drop in the open valve is the least possible. These types of valves therefore require no differential pressure to keep them open.

Stainless steel solenoid valves, type EVRS 3-20 and EVRST 10-20

Material specification

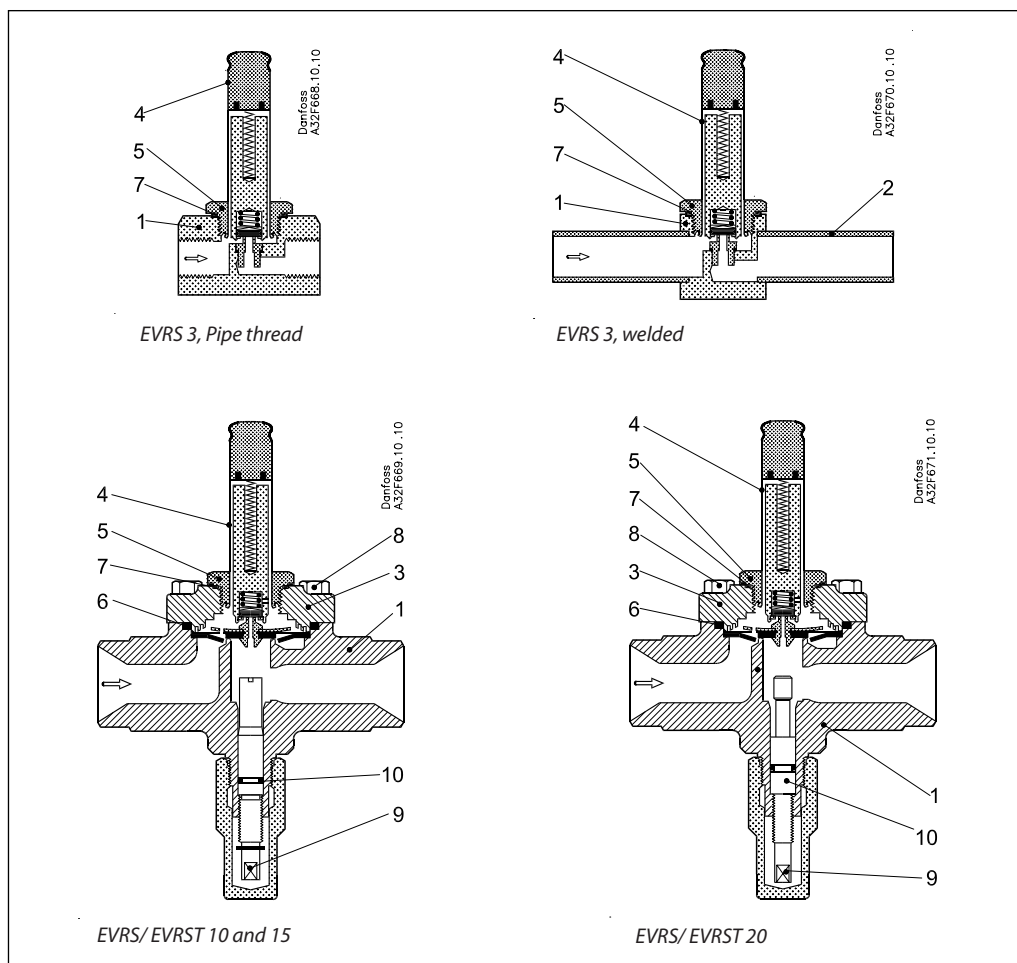

		Solenoid valves				Standard		
No.	Description	Type	Material	Analysis	Mat.no.	W.no.	DIN	EN
1	Valve housing	EVRS 3	Stainless steel	X8 CrNiS 18-9		1.4305		10088
		EVRS (T) 10/15/20	Stainless steel	X6 CrNi 18-9		1.4308	17455	
2	Welding tube	EVRS 3	Stainless steel	X2 CrNiMo 17-12-2		1.4404	17455	
3	Cover	EVRS (T) 10/15/20	Stainless steel	X6 CrNi 18-9		1.4308	17455	
4	Armature tube	EVRS(T) 3/10/15/20	Stainless steel	X2 CrNi 19-11		1.4306		10088
5	Armature tube nut	EVRS(T) 3/10/15/20	Stainless steel	X8 CrNi 19-11		1.4305		10088
6	Gasket	EVRS(T) 3/10/15/20	Rubber	Cr				
7	Gasket armature tube	EVRS(T) 10/15/20	Al gasket	Al 99.5		3.0255		10210
8	Screws	EVRS(T) 10/15/20	Stainless steel	A2-70			3506	
9	Spindle for man. oper.	EVRS(T) 10/15/20	Stainless steel	X8 CrNiS 18-9		1.4305		10088
10	Gasket	EVRS(T) 10/15/20	Rubber	Cr				

Stainless steel solenoid valves, type EVRS 3-20 and EVRST 10-20

Dimensions and weights

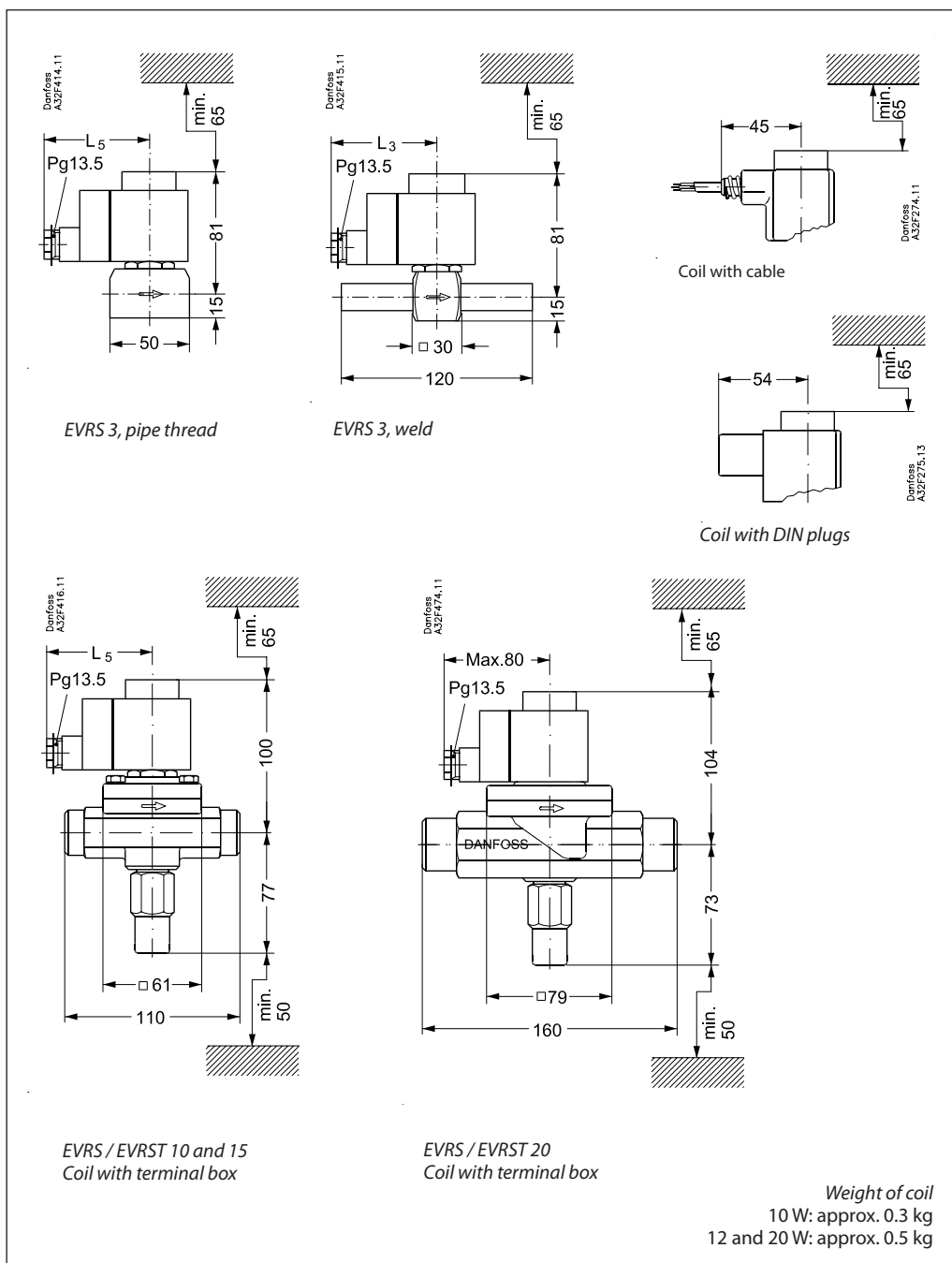

Type	L ₅ max.		Weight with coil [kg]
	10 W	12 W 20 W	
	[mm]	[mm]	
EVRS 3, pipe thread	75	85	0.7
EVRS 3, weld	75	85	0.6
EVRS / EVRST 10	75	85	1.2
EVRS / EVRST 15	75	85	1.3
EVRS / EVRST 20	75	85	2.0

Solenoid coil

Types BB, BE, BF, BG, and BN

Contents

	Page
Features	89
Technical data	90
Approvals	90
Connection	90
Ordering	91
Dimension and weight	94

Solenoid coil

Types BB, BE, BF, BG, and BN

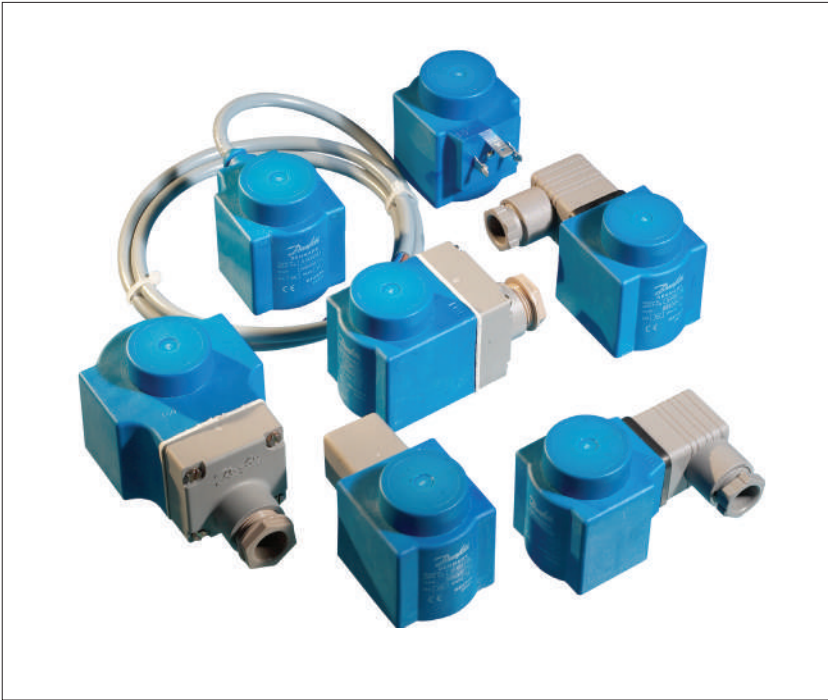

The coils are specially designed to operate in the aggressive environment of high humidity and temperature fluctuations that you find in most refrigeration systems.

The Clip-on fastening system ensures a faultless installation and makes the coils easy to mount and dismount. A Danfoss Clip-on coil can be mounted without any tools at all, and it is simple to dismount the coil by means of a screwdriver.

The Clip-on coils are available for the entire range of Danfoss solenoid valves for refrigeration, freezing and air conditioning purposes.

Features











- Encapsulated coils with long operating life, even under extreme conditions.
- Standard coils for AC or DC
- Standard coils available with 3-core cable, terminal box or DIN plugs.
- Standard coils from 12 V to 420 V, 50, 60 or 50/60 Hz.
- Standard coils dimensioned for max. opening differential pressure (MOPD) of up to 38 bar.
- Coils can be fitted without the use of tools.

Approvals

- RoHS Directive 2011/65/EU
- Low Voltage Directive (LVD) 2014/35/EU
- EMC Directive 2014/30/EU

Solenoid coil, Types BB, BE, BF, BG, and BN

Technical data

Data	Solenoid coil type											
	1m 3-core cable		Terminal box		DIN spade and protection cap		DIN spade		1m 3-core cable		Terminal box	
												
Enclosure	IP67	IP67	IP67	IP67	IP20	IP00	IP67	IP67	IP20	IP00	IP67	
Pollution degree	4	4	4	4	3	3	4	4	3	3	3	
Conductor area [mm ²]	0.75	0.75 - 1.5	0.75 - 1.5	0.75 - 1.5	0.75 - 1.5	0.75 - 1.5	0.75	0.75 - 1.5	0.75 - 1.5	0.75 - 1.5	0.75 - 1.5	
Cable size [mm]	Ø6.6	Ø6.0 - Ø11	Ø6.0 - Ø11	Ø6.0 - Ø11	Ø6.0 - Ø11	Ø6.0 - Ø11	Ø6.6	Ø6.0 - Ø11	Ø6.0 - Ø11	Ø6.0 - Ø11	Ø6.0 - Ø11	
Rated impulse voltage [kV], if altitude < 4000 m	4	4	4	4	4	4	4	4	4	4	4	
Humidity [R.H.]	0 - 100%	0 - 100%	0 - 100%	0 - 100%	0 - 97% non-condensation condition	0 - 97% non-condensation condition	0 - 100%	0 - 100%	0 - 97% non-condensation condition	0 - 97% non-condensation condition	0 - 100%	
Type of control	1	1	1	1	1	1	1	1	1	1	1	
Safety classification	Class I	Class I	Class I	Class I	Class I	Class I	Class I	Class I	Class I	Class I	Class I	
Max. altitude above sea level [m]	4000	4000	4000	4000	4000	4000	4000	4000	4000	4000	4000	

Note:

For DIN plug, impulse withstand voltage is 3.1 kV for 2000 m < Altitude < 4000 m

 Safety notes for flammable refrigerants (R290, R600, R600A, R32, R1234ze, and R1234yf):

1. The products (only refer to IP65/67 coils) are validated in accordance to ISO 5149, IEC 60335 (ref. IEC/EN 60079-15). Ignition risk is evaluated in accordance to ISO 5149 and IEC 60335 (ref. IEC/EN 60079-15). See safety note below.
2. Please make sure that there is no spark, arc during the application, especially the connection of coils.
3. Follow the instruction to mount the coil correctly and apply the o-ring for sealing, to prevent the moisture penetrate inside the coils.
4. Always install a fuse ahead of the coil to avoid short circuit (fuse size should be around 2 times of rated current, and time lag: medium);
5. The coil used in an area of not more than pollution degree 2.

 Safety notes:

1. The product (only refer to IP65/67 coils) can be applied on systems with R290, R600, R600A, R32, R1234ze, and R1234yf as the working fluid.
2. For countries where safety standards are not an indispensable part of the safety system Danfoss recommend the installer to get a third party approval of the system containing flammable refrigerant.
3. Note, please follow specific selection criteria stated in the datasheet for these particular refrigerants.
4. Note that the product (only refer to IP65/67 coils) has NOT been verified ATEX or IECEx or IEC 60079 series zone 2 compliant. This product is only validated for systems in compliance with ISO5149, IEC 60335 (ref. IEC/EN 60079-15). It is the responsibility of the user to verify such compliance. Improper use can cause explosion, fire, leakage potentially causing death, personal injury, or damage to property.

Approvals

See under the required solenoid valve.

Connection

3-core cable

The external thread in the screwed cable entry suits flexible steel hose or corresponding cable protection (3 x 0.75 mm²).

Terminal box

Leads are connected to terminal screws in the terminal box. The box is fitted with a Pg 13.5 screwed entry for 6 - 14 mm cable.
Max. lead cross section: 2.5 mm².

DIN plugs

The three pins on the coil can be fitted with spade tabs, 6.3 mm wide (to EN175301-803A).
The two current carrying pins can also be fitted with spade tabs, 4.8 mm wide.
Max. lead cross section: 1.5 mm².
Use of the protective cap supplied will prevent inadvertent contact with live parts.

DIN socket

(to EN175301-803A)

Leads are connected in the socket. The socket is fitted with a Pg 11 screwed entry for 6 - 12 mm.

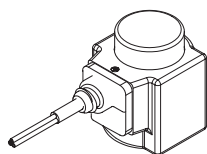
Solenoid coil, Types BB, BE, BF, BG, and BN
Ordering
BF solenoid coil with 1m 3-core cable IP67

Type	Valve type	Tambient [°C]	Supply voltage [V]	Voltage variation	Frequency [Hz]	Power consumption		Code no.
						[W]	[VA]	
BF024AS	EVR 2 – EVR 40 (NC) EVR 6 – EVR 22 (NO) EVRH 10 – EVR 40 EVRC EVRA EVRAT EVRS / EVRST EVM (NC)	-40T80	24	-15%, +10%	50	12	20	018F6257
BF230AS		-40T80	230	-15%, +10%	50	12	22	018F6251
BF240AS		-40T80	220	-15%, +10%	50	11	20	
BF400AS		-40T80	240	-15%, +10%	50	11	19	018F6252
BF024BS		-40T80	380 / 400	±10%	50	10	21	018F6253
BF024BS		-40T80	24	-15%, +10%	60	14	25	018F6265
BF115CS		-40T80	115	-15%, +10%	60	13	22	018F6260
		-40T80	100	-15%, +10%	50	11	19	
BF220BS		-40T80	220	-15%, +10%	60	14	23	018F6264
BF110CS		-40T50	110	±10%	50	15	29	018F6280
		-40T50	110	±10%	60	13	23	
BF230CS		-40T50	220 – 230	±10%	50	16	31	018F6282
		-40T50	220 – 230	±10%	60	14	24	

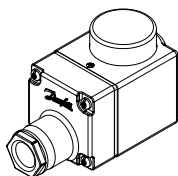
BE solenoid coil with terminal box IP67

Type	Valve type	Tambient [°C]	Supply voltage [V]	Voltage variation	Frequency [Hz]	Power consumption		Code no.
						[W]	[VA]	
BE012AS	EVR 2 – EVR 40 (NC) EVR 6 – EVR 22 (NO) EVRH 10 – EVR 40 EVRC EVRA EVRAT EVRS / EVRST EVM (NC)	-40T80	12	-15%, +10%	50	10	18	018F6706
BE024AS		-40T80	24	-15%, +10%	50	12	21	018F6707
BE042AS		-40T80	42	-15%, +10%	50	10	21	018F6708
BE048AS		-40T80	48	-15%, +10%	50	10	21	018F6709
BE115AS		-40T80	115	-15%, +10%	50	11	19	018F6711
BE230AS		-40T80	230	-15%, +10%	50	12	22	018F6701
		-40T80	220	-15%, +10%	50	11	19	
BE240AS		-40T80	240	-15%, +10%	50	11	19	018F6702
BE440CS		-40T80	380 – 400	-15%, +10%	50	13	23	018F6703
		-40T80	440	-15%, +10%	60	14	24	
BE440AS		-40T80	420	-15%, +10%	50	11	21	018F6704
BE024BS		-40T80	24	-15%, +10%	60	14	25	018F6715
BE115CS		-40T80	100	-15%, +10%	50	11	19	018F6710
		-40T80	115	-15%, +10%	60	13	22	
BE220BS		-40T80	220	-15%, +10%	60	13	23	018F6714
BE240CS		-40T80	200	-15%, +10%	50	11	20	018F6713
		-40T80	240	-15%, +10%	60	15	25	
BE110CS		-40T50	110	±10%	50	15	28	018F6730
		-40T50	110	±10%	60	13	22	
BE230CS		-40T50	220 – 230	±10%	50	17	31	018F6732
		-40T50	220 – 230	±10%	60	14	24	

See „Opening differential pressure“ under „Technical data“ for the valve concerned.
When replacing a coil with terminal box, it is sufficient to change the coil unit itself. Therefore, order coil with DIN plugs and protective cap.

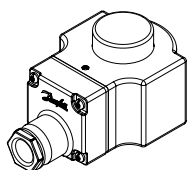
Solenoid coil, Types BB, BE, BF, BG, and BN
**Ordering
BG solenoid coil with
terminal box IP67**

Type	Valve type	Tambient [°C]	Supply voltage [V]	Voltage variation	Frequency [Hz]	Power consumption		Code no.	
						[W]	[VA]		
BG024AS	EVR 3 – EVR 40 EVRC EVRA EVRAT EVRST EVM (NC/ NO)	-40T80	24	-15%, +10%	50	11	21	018F6807	
BG048AS		-40T80	48	-15%, +10%	50	12	26	018F6809	
BG110AS		-40T80	110	-15%, +10%	50	13	25	018F6811	
BG230AS		-40T80	230	-15%, +10%	50	15	28	018F6801	
		-40T80	220	-15%, +10%	50	13	25		
BG240AS		-40T80	240	-15%, +10%	50	13	25	018F6802	
BG400AS		-40T80	380 / 400	-15%, +10%	50	12	26	018F6803	
BG024BS		-40T80	24	-15%, +10%	60	12	26	018F6815	
BG110BS		-40T80	110	-15%, +10%	60	16	29	018F6813	
BG220BS		-40T80	220	-15%, +10%	60	16	29	018F6814	
BG012DS	EVR 2 – 8 EVR 25 – 40 EVRA 3 – EVRA 15 (NC) EVRA 25 – EVRA 40 (NC) EVRAT 10 – EVRAT 15 (NC) EVRST/ EVRST 3 – EVRS/ EVRST 15 EVM (NC/ NO)	-40T50	12	±10%	DC	20	–	018F6856	
BG024DS		-40T50	24	±10%	DC	16	–	018F6857	
BG048DS		-40T50	48	±10%	DC	20	–	018F6859	
BG110DS		-40T50	110	±10%	DC	16	–	018F6860	
BG115DS		-40T50	115	±10%	DC	19	–	018F6861	
BG220DS		-40T50	220	±10%	DC	20	–	018F6851	
BG012DS		EVR 10 – 22	-40T50	12	±10%	DC	20	–	018F6886
BG024DS		EVRC 15 – 20	-40T50	24	±10%	DC	20	–	018F6887
BG048DS	EVRC 20	-40T50	48	±10%	DC	20	–	018F6889	
BG110DS	EVRA 20 EVRAT 20	-40T50	110	±10%	DC	20	–	018F6890	
BG220DS	EVRST 20	-40T50	220	±10%	DC	20	–	018F6881	

See „Opening differential pressure“ under „Technical data“ for the valve concerned.

When replacing a coil with terminal box, it is sufficient to change the coil unit itself. Therefore, order coil with DIN plugs and protective cap.

Solenoid coil, Types BB, BE, BF, BG, and BN

Ordering BE solenoid coil with DIN spade and protection cap IP20

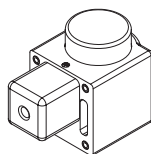

Type	Valve type	Tambient [°C]	Supply voltage [V]	Voltage variation	Frequency [Hz]	Power consumption		Code no.
						[W]	[VA]	
BE024AS	EVR 2 – EVR 40 (NC) EVR 6 – EVR 22 (NO) EVRH 10 – EVRH 40 EVRC EVRA EVRAT EVRST EVRST EVM (NC)	-40T80	24	-15%, +10%	50	12	21	018F6182
BE230AS		-40T80	230	-15%, +10%	50	12	22	018F6176
BE240AS		-40T80	220	-15%, +10%	50	11	19	018F6177
BE420AS		-40T80	240	-15%, +10%	50	11	19	018F6179
BE115CS		-40T80	420	-15%, +10%	50	10	21	018F6179
		-40T80	100	-15%, +10%	50	11	19	018F6185
BE220BS		-40T80	115	-15%, +10%	60	13	22	018F6185
		-40T80	220	-15%, +10%	50	13	23	018F6189
BE110CS		-40T50	110	±10%	50	15	28	018F6192
		-40T50	110	±10%	60	13	22	018F6192
BE230CS	-40T50	220-230	±10%	50	17	31	018F6193	
	-40T50	220-230	±10%	60	14	24	018F6193	

BB solenoid coil with DIN spade*)

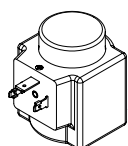

Type	Valve type	Tambient [°C]	Supply voltage [V]	Voltage variation	Frequency [Hz]	Power consumption		Code no.
						[W]	[VA]	
BB024AS	EVR 2 – EVR 40 (NC) EVR 6 – EVR 22 (NO) EVRH 10 – EVRH 40 EVRC EVRA EVRAT EVRST EVRST EVM (NC)	-40T80	24	-15%, +10%	50	11	19	018F7358
BB115AS		-40T80	115	-15%, +10%	50	11	19	018F7361
BB230AS		-40T80	220 - 230	-15%, +10%	50	11	19	018F7351
BB240AS		-40T80	240	-15%, +10%	50	11	19	018F7352
BB024BS		-40T80	24	-15%, +10%	60	14	23	018F7365
		-40T50	110	±10%	50	15	28	018F7360
BB110CS		-40T50	110	±10%	60	13	22	018F7360
		-40T50	220 - 230	±10%	50	16	31	018F7363
BB230CS		-40T50	220 - 230	±10%	50	16	31	018F7363
		-40T50	220 - 230	±10%	60	13	24	018F7363

See „Opening differential pressure“ under „Technical data“ for the valve concerned.
When replacing a coil with terminal box, it is sufficient to change the coil unit itself. Therefore, order coil with DIN plugs and protective cap.
*) Can only be used with DIN plug.

BN special solenoid coil with terminal box IP67

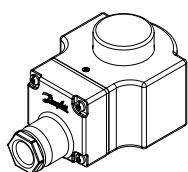

Type	Valve type	Tambient [°C]	Supply voltage [V]	Voltage variation	Frequency [Hz]	Power consumption		Code no. 1)
						[W]	[VA]	
BN024AS	EVR 2 – EVR 40 (NC) EVR 6 – EVR 22 (NO)	-40T50	24	-15%, +10%	50	24	49	018F6904
BN024BS	EVRH 4 – EVRH 40 EVRC/ EVRA/ EVRAT/ EVRST/ EVRST/ EVM (NC)	-40T50	24	-15%, +10%	60	22	42	018F6906
BN230AS	EVRH 4 – EVRH 40 EVRC/ EVRA/ EVRAT/ EVRST/ EVRST/ EVM (NC)	-40T50	230	-15%, +10%	50	19	43	018F6905

1) Recommended use for EVRH with high MOPD (38 bar).

Coil with DIN plug

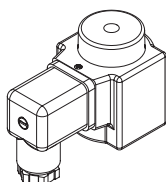

Terminal box	With built-in light emitting indicator diode for solenoid valves	018Z0089
DIN plug	Enclosure IP65, EN 175301-803A	042N0156

Dimension and weight

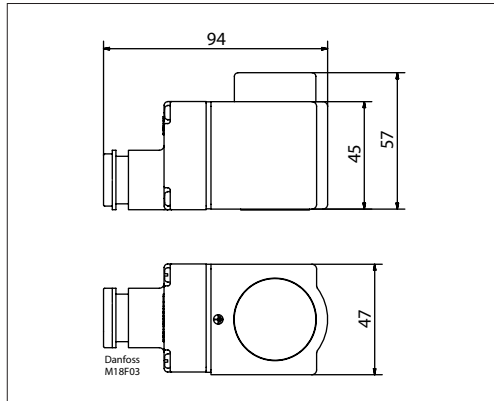

Terminal box 10 W
Weight 0.29 Kg

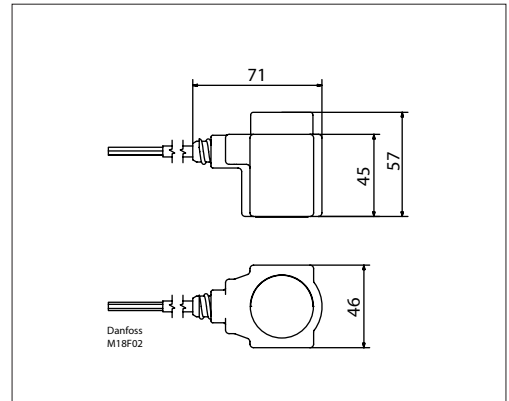

Cable 10 W
Weight 0.29 Kg

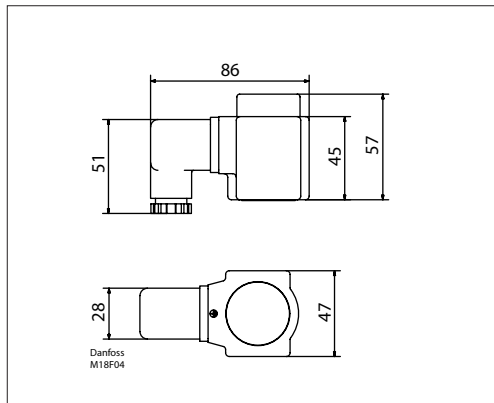

DIN socket 10 W
Weight 0.24 Kg

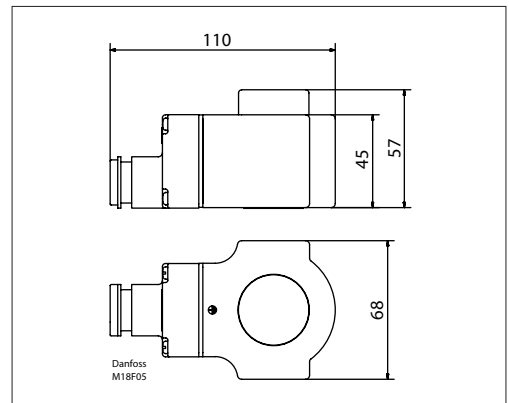

Terminal box 12 - 20 W
Weight 0.55 Kg