

---

# DataSheet

---

<b>System Configuration .....</b>	<b>2</b>
<b>G5 Series AC Servomotor/Servo Drives with built-in EtherCAT Communications .</b>	<b>2</b>
<b>G5 Series Linear Motor/Servo Drives with built-in EtherCAT Communications</b>	
<b>Linear Motor Type .....</b>	<b>4</b>
<b>G5-series AC Servomotors/Servo Drives with General-purpose Pulse Train or Analog Inputs .....</b>	<b>6</b>
<b>G5-series AC Servomotors/Servo Drives with Built-in MECHATROLINK-II Communications .....</b>	<b>8</b>
<b>G5-series AC Servo Drives with Built-in EtherCAT Communications .....</b>	<b>10</b>
<b>Contents</b>	
<b>Ordering Information</b>	
<b>Specifications</b>	
<b>Components and Functions</b>	
<b>Dimensions</b>	
<b>G5-series AC Servo Drives with Built-in EtherCAT Communications Linear Motor Type .....</b>	<b>22</b>
<b>Contents</b>	
<b>Ordering Information</b>	
<b>Specifications</b>	
<b>Components and Functions</b>	
<b>Dimensions</b>	
<b>G5-Series AC Servo Drives with General-purpose Pulse Train or Analog Inputs .....</b>	<b>27</b>
<b>Contents</b>	
<b>Ordering Information</b>	
<b>Specifications</b>	
<b>Components and Functions</b>	
<b>Dimensions</b>	
<b>G5-series AC Servo Drives with Built-in MECHATROLINK-II Communications.....</b>	<b>38</b>
<b>Contents</b>	
<b>Ordering Information</b>	
<b>Specifications</b>	
<b>Components and Functions</b>	
<b>Dimensions</b>	
<b>G5-series AC Servomotors .....</b>	<b>47</b>
<b>Contents</b>	
<b>Ordering Information</b>	
<b>Specifications</b>	
<b>Dimensions</b>	
<b>G5-series Linear Motor .....</b>	<b>74</b>
<b>Contents</b>	
<b>Ordering Information</b>	
<b>Specifications</b>	
<b>Components and Functions</b>	
<b>Dimensions</b>	
<b>G5-series Decelerator (Backlash: 3 Arcminutes Max./ 15 Arcminutes Max.)..</b>	<b>89</b>
<b>Related Manuals .....</b>	<b>104</b>

Sysmac is a trademark or registered trademark of OMRON Corporation in Japan and other countries for OMRON factory automation products.

Windows is either registered trademarks or trademarks of Microsoft Corporation in the United States and/or other countries.

EtherCAT® is registered trademark and patented technology, licensed by Beckhoff Automation GmbH, Germany. Other company names and product names in this document are the trademarks or registered trademarks of their respective companies.

When connecting a Servo Drive to the NJ5 series Machine Automation Controller, it is recommended that you use the Servo Drive with Built-in EtherCAT Communications, R88D-KN□□□-ECT, with unit version 2.1 or later.

# G5 Series AC Servomotor/Servo Drives with built-in EtherCAT Communications

# R88M-K/R88D-KN□-ECT

## System Configuration

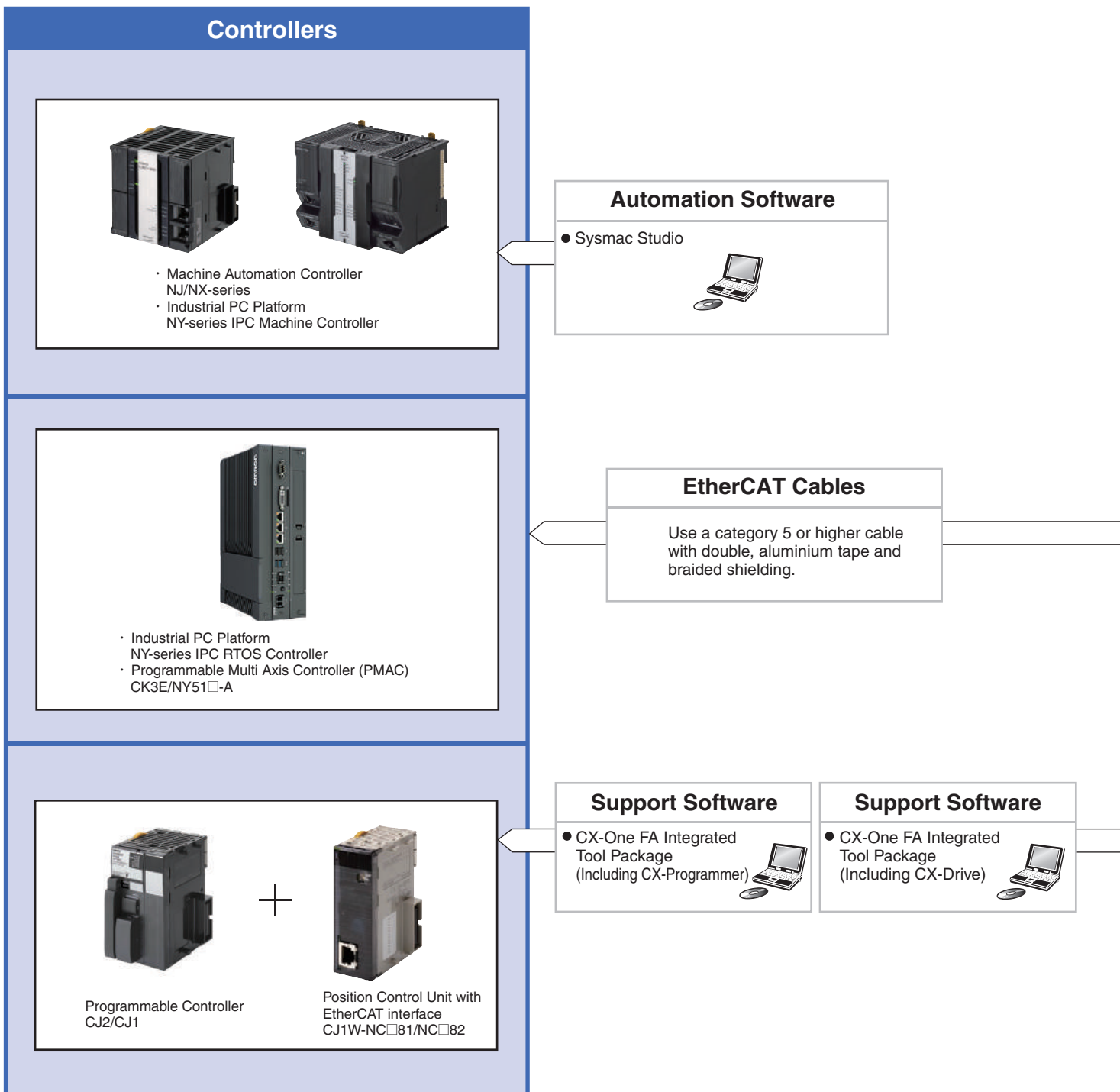

Note: PMAC is an abbreviation for Programmable Multi Axis Controller.

# High-Speed and High-Precision G5 Series EtherCAT Communications with the Controller



- High-accuracy positioning with fully-closed control.
- Servo Drives for 400VAC globally widens applicable systems and environment, including large-scale equipment.
- Safe design and Safe Torque Off (STO) function.
- Vibration can be suppressed in acceleration/deceleration even in low-rigidity mechanical systems.



G5-Series  
System Configuration

EtherCAT Communications  
AC Servo Drive

EtherCAT Communications  
Linear Motor Type  
AC Servo Drive

General-purpose Inputs  
AC Servo Drive

ML-II Type  
AC Servo Drive

AC Servomotors

Linear Motor

Decelerator

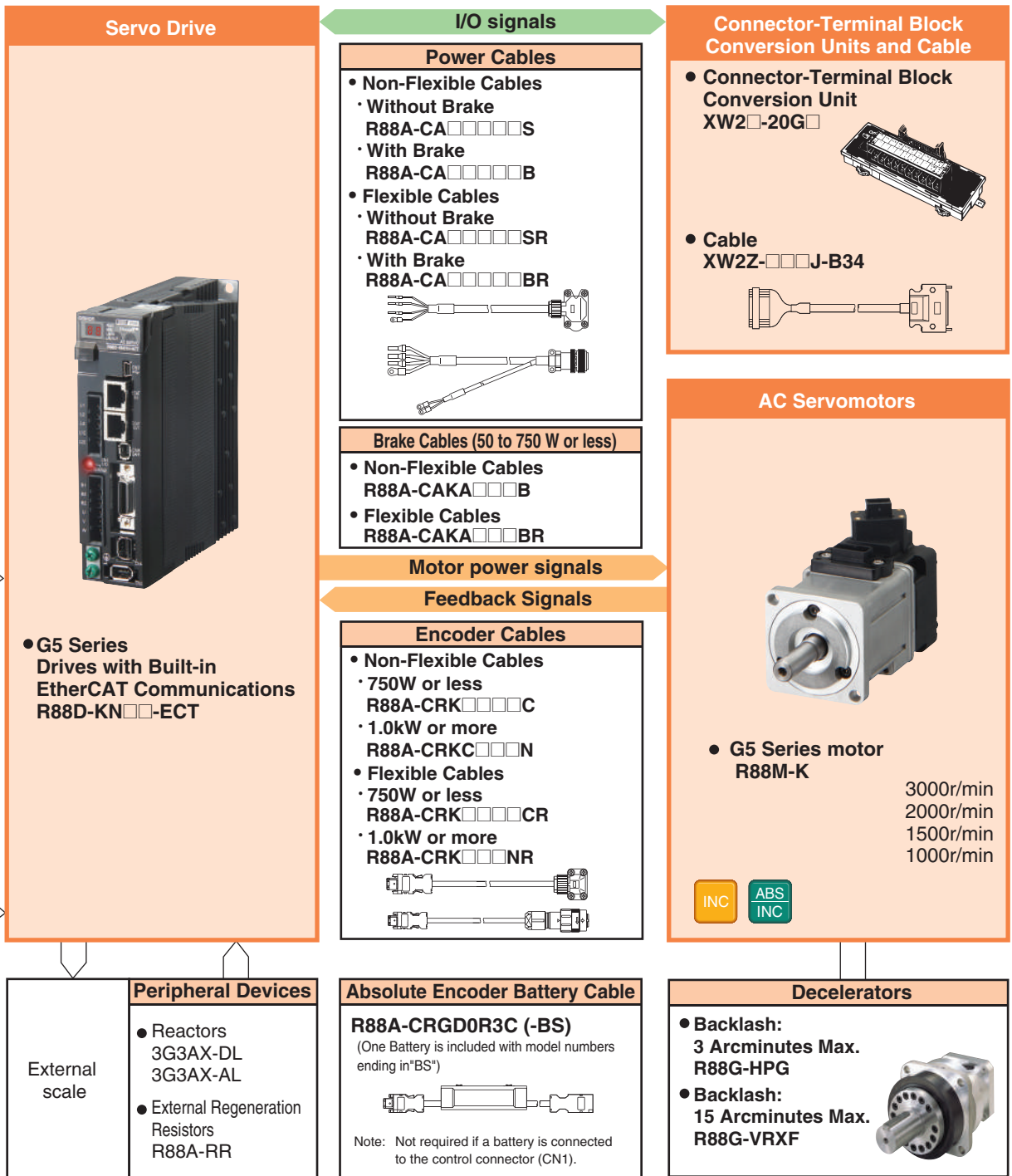

# G5 Series Linear Motor/Servo Drives with built-in EtherCAT Communications Linear Motor Type R88L-EC/R88D-KN□-ECT-L

## System Configuration

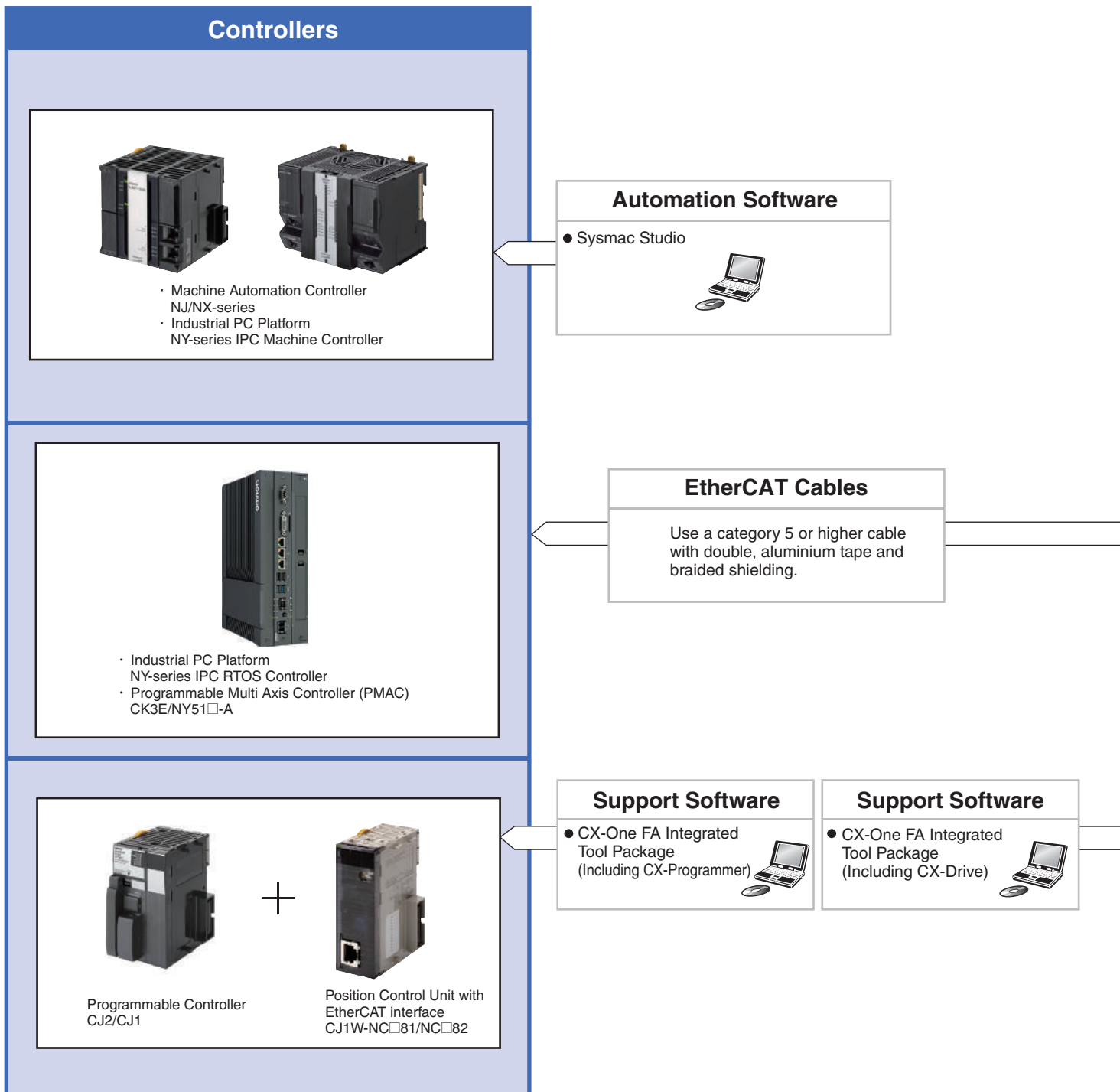

Note: PMAC is an abbreviation for Programmable Multi Axis Controller.

## Linear Motor for Higher-speed and Higher-precision

- Inherited functions and performance of G5 series and EtherCAT communications achieve high-speed and high-precision positioning.
- Lineup of compact and high-thrust iron-core motor type and cogging-free ironless motor type with excellent speed stability.
- Same Iron-core motor type for 200V AC and 400V AC.
- Quick setup by automatic setup function.

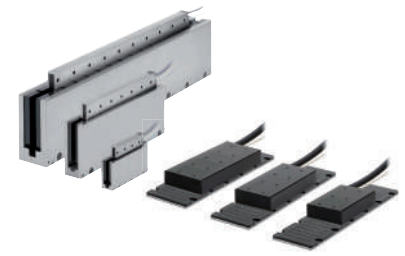

G5-Series  
System Configuration

EtherCAT Communications  
AC Servo Drive

EtherCAT Communications  
Linear Motor Type  
AC Servo Drive

General-purpose Inputs  
AC Servo Drive

ML-II Type  
AC Servo Drive

AC Servomotors

Linear Motor

Decelerator

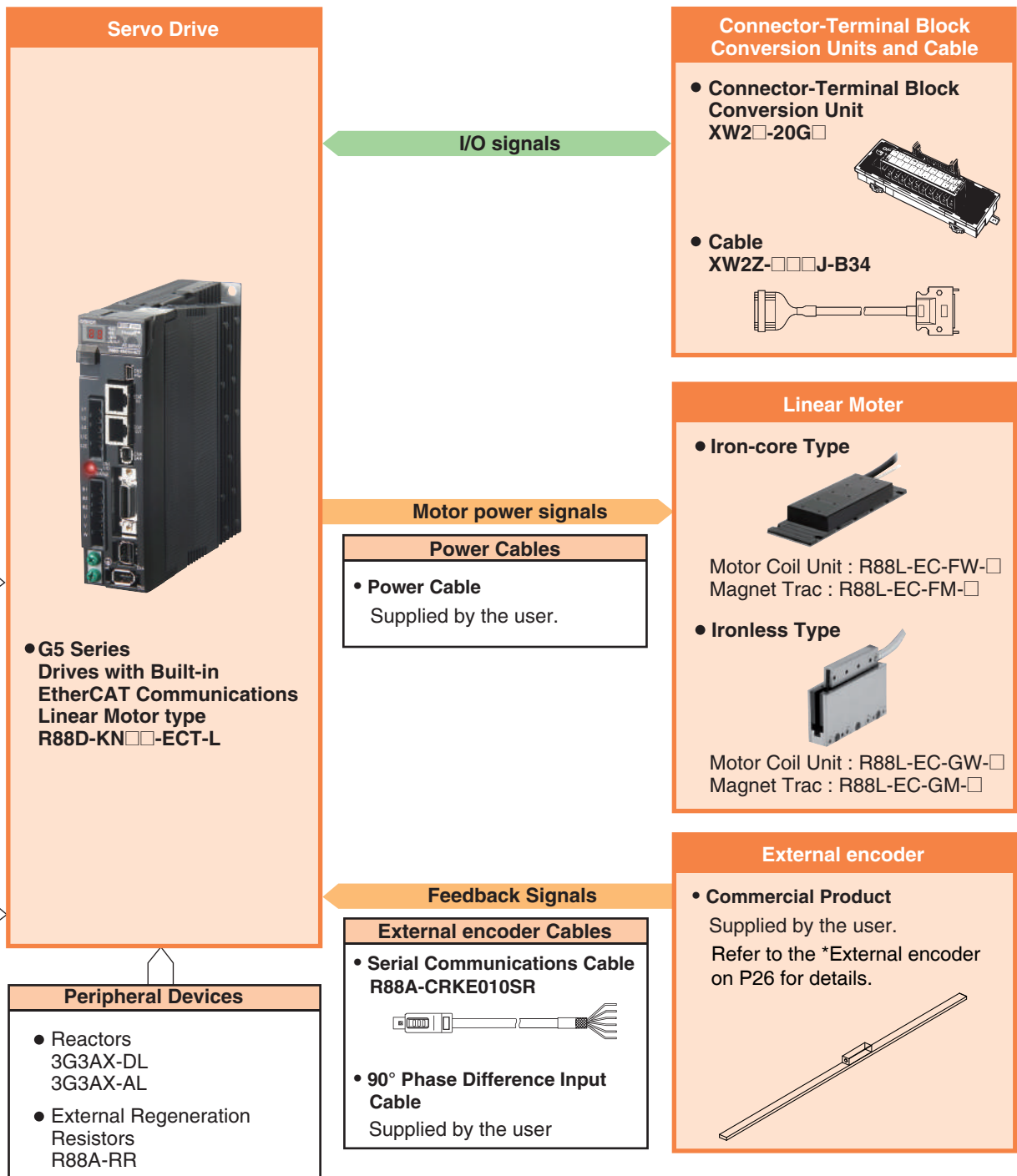

# G5-series AC Servomotors/Servo Drives with General-purpose Pulse Train or Analog Inputs

# R88M-K/R88D-KT

## System Configuration

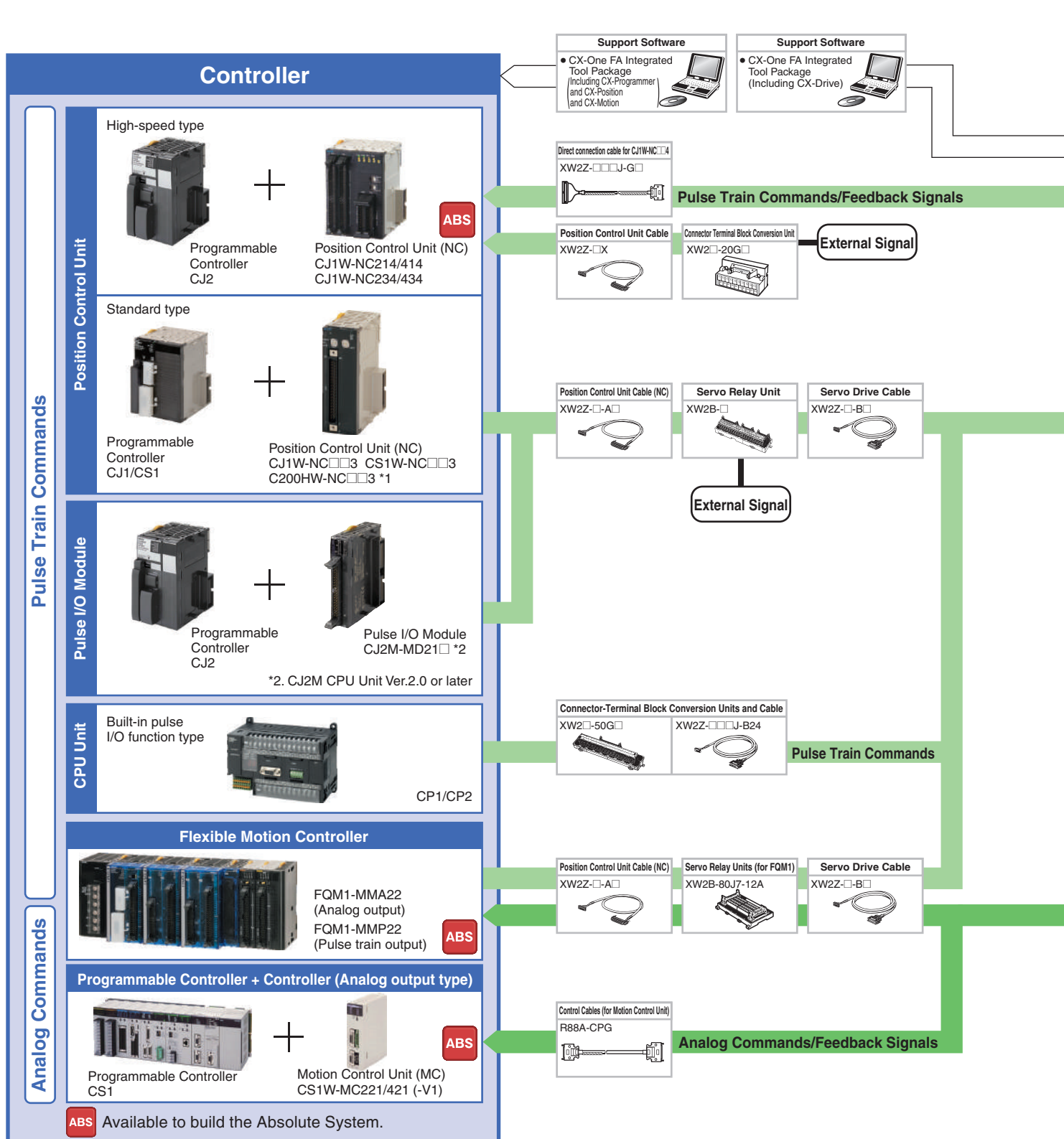

\*1. C200HW-NC was discontinued.

# The Preeminent Servo That Revolutionizes Motion Control



(Ro)

- Industry Top-class Tracking Performance.  
Speed Response Frequency of 2 kHz.
- Best Positioning Accuracy\*.  
Featuring a 20-bit high-resolution incremental encoder.  
\* 8 times the resolution of previous OMRON models
- High-precision Positioning.  
Fully Closed Loop Control Is a Standard Feature.
- Conforms to the Latest International Standards.  
Safety and Productivity.
- Globalization. Lineup of 400 VAC Servomotors.

G5-Series  
System Configuration

EtherCAT Communications  
AC Servo Drive

EtherCAT Communications  
Linear Motor Type  
AC Servo Drive

General-purpose Inputs  
AC Servo Drive

ML-II Type  
AC Servo Drive

AC Servomotors

Linear Motor

Decelerator

USB communications

## Servo Drive



• G5 Series driver  
R88D-KT

100 VAC  
200 VAC  
400 VAC

## Motor power signals

### Power Cables

- Non-flexible Cables
  - Without Brake  
R88A-CA@@@@S
  - With Brake  
R88A-CA@@@@B
- Flexible Cables
  - Without Brake  
R88A-CA@@@@SR
  - With Brake  
R88A-CA@@@@BR

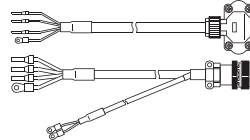

### Brake Cables (50 to 750 W or less)

- Non-flexible Cables  
R88A-CAKA@@@B
- Flexible Cables  
R88A-CAKA@@@@BR

## Feedback Signals

### Encoder Cables

- Non-Flexible Cables
  - 750W or less  
R88A-CRK@@@@C
  - 1.0kW or more  
R88A-CRKC@@@@N
- Flexible Cables
  - 750W or less  
R88A-CRK@@@@CR
  - 1.0kW or more  
R88A-CRK@@@@NR

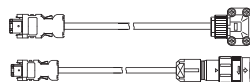

## AC Servomotors



• G5 Series motor  
R88M-K

3,000 r/min  
2,000 r/min  
1,500 r/min  
1,000 r/min



## Peripheral Devices

External scale

- Reactors  
3G3AX-DL  
3G3AX-AL
- External Regeneration Resistors  
R88A-RR

## Absolute Encoder Battery Cable

R88A-CRGD0R3C (-BS)  
(One Battery is included with Servo Drivers with model numbers ending in "BS.")

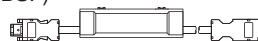

\* Not required if a battery is connected to the control connector (CN1).

## Decelerators

- Backlash:  
3 Arcminutes Max.  
R88G-HPG
- Backlash:  
15 Arcminutes Max.  
R88G-VRXF



# R88M-K/R88D-KN□-ML2

## System Configuration

### Controllers (MECHATROLINK-II type)

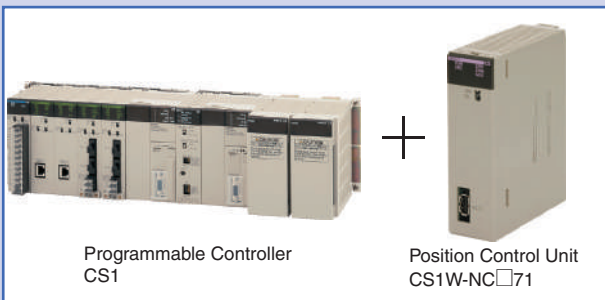
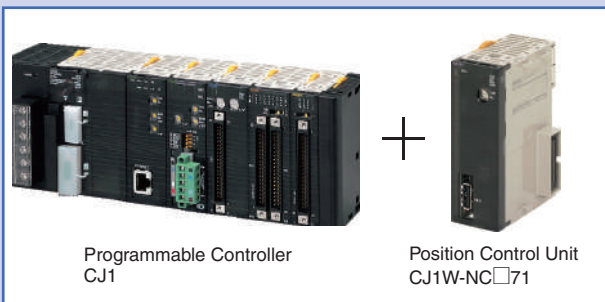

**Support Software**

- CX-One FA Integrated Tool Package (Including CX-Programmer and CX-Position and CX-Motion)

**Support Software**

- CX-One FA Integrated Tool Package (Including CX-Drive)

### MECHATROLINK-II

**MECHATROLINK-II Cables**

(With ring core and USB connector on both ends)  
**FNY-W6003-□□ (OMRON model number)**

(Without ring core USB connector on both ends)  
**FNY-W6002-□□ (OMRON model number)**

**MECHATROLINK-II Repeater**

		Maximum transmission distance	
		0 to 30 m	30 to 50 m
Number of connected devices	1 to 15	Repeater not required.	Repeater not required.
	16	Repeater not required.	Repeater required.



# High-Speed and High-Precision G5 Series MECHATROLINK-II Communications with the Controller

- Data transfer using MECHATROLINK-II Communications:  
All control data that can be interfaced between the Servo Driver and the Controller is transmitted using data communications. This enables maximizing the Servomotor performance without restricting the transmission performance of the control signals.
- Having a communications module built into the Servo Driver significantly saves space in the control panel.

G5-Series System Configuration  
EtherCAT Communications AC Servo Drive  
EtherCAT Communications Linear Motor Type AC Servo Drive  
General-purpose Inputs AC Servo Drive  
ML-II Type AC Servo Drive  
AC Servomotors  
Linear Motor  
Decelerator

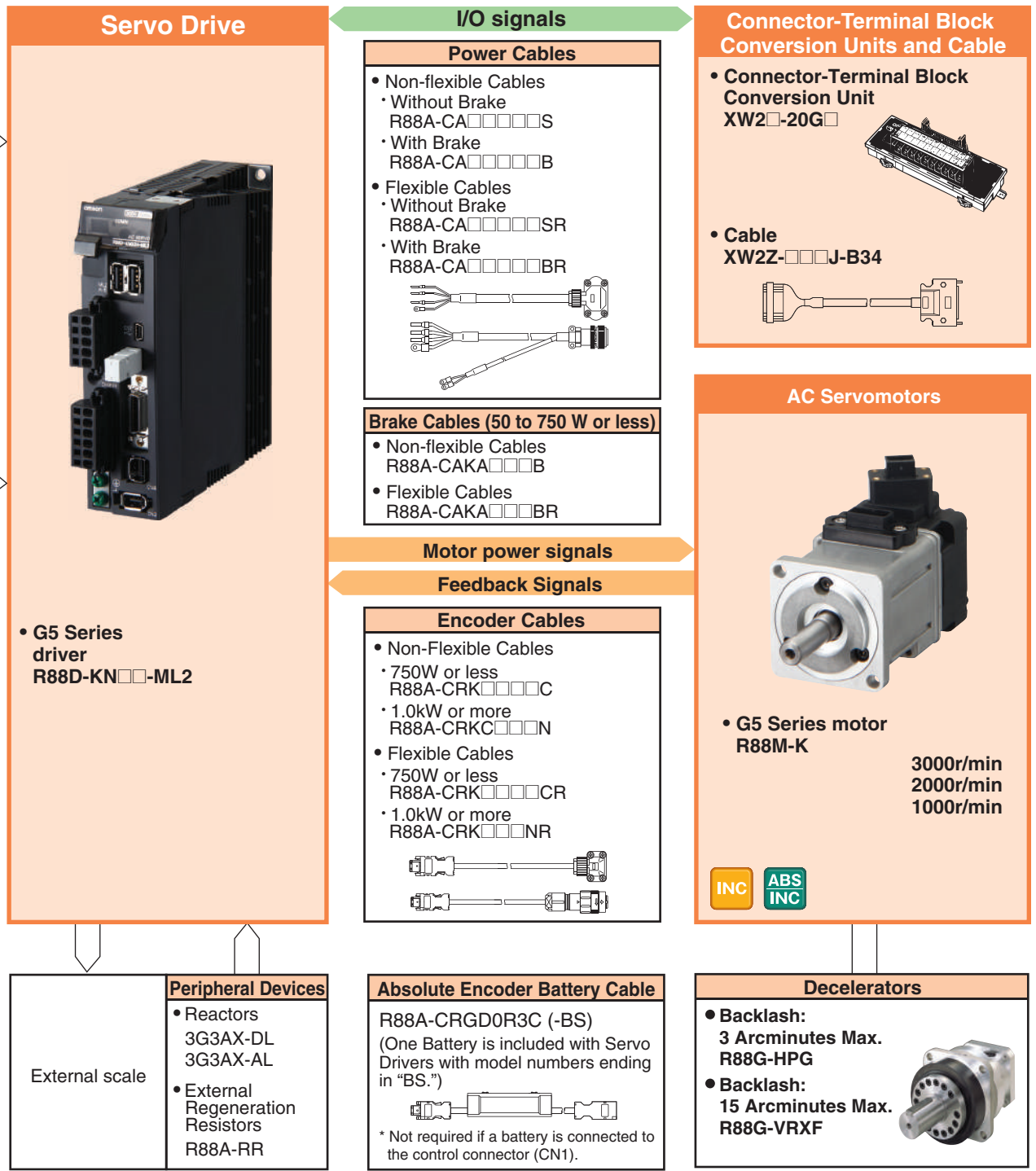

USB communications

USB communications

# G5-series AC Servo Drives with Built-in EtherCAT Communications

# R88D-KN□-ECT

## Contents



- Ordering Information
- Specifications
  - General Specifications
  - Characteristics
    - Servo Drives with Single-phase 100 VAC Input Power
    - Servo Drives with Single-phase or Three-phase 200 VAC Input Power
    - Servo Drives with Three-phase 400 VAC Input Power
  - EtherCAT Communication Specifications
- Version Information
- Names and Functions
  - Servo Drive Part Names
  - Functions
- Dimensions

## Ordering Information

Refer to the Ordering Information.

## Specifications

### General Specifications

Item		Specifications	
Ambient operating temperature and operating humidity		0 to 55°C, 85% max. (with no condensation)	
Storage ambient temperature and humidity		-20 to 65°C, 85% max. (with no condensation)	
Operating and storage atmosphere		No corrosive gases	
Vibration resistance		10 to 60 Hz and at an acceleration of 5.88 m/s <sup>2</sup> or less (Not to be run continuously at a resonance point)	
Insulation resistance		Between power supply terminals/power terminals and FG terminal: 0.5 MΩ min. (at 500 VDC)	
Dielectric strength		Between power supply/power line terminals and FG terminal: 1,500 VAC for 1 min at 50/60 Hz	
Protective structure		Built into panel	
International standard	EC Directives	EMC Directive	EN 55011, EN 61000-6-2, IEC 61800-3
		Low Voltage Directive	EN 61800-5-1
		Machinery Directives	EN954-1 (Cat.3), EN ISO 13849-1: 2008 (Category 3) (PLc,d), ISO 13849-1: 2006 (Category 3) (PLc,d), EN61508 (SIL2), EN62061 (SIL2), EN61800-5-2 (STO), IEC61326-3-1 (SIL2)
	UL standards		UL 508C
	CSA standards		CSA C22.2 No. 14
Korean Radio Regulations (KC)		Certified	

**Note: 1.** The above items reflect individual evaluation testing. The results may differ under compound conditions.

**Note: 2.** Always disconnect all connections to the Servo Drive before you perform insulation resistance tests on it. If you perform an insulation resistance test while the Servo Drive is connected, the Servo Drive may be damaged. Never perform dielectric strength tests on the Servo Drive. Failure to follow this precaution may result in damaging internal elements.

**Note: 3.** Some Servo Drive parts will require maintenance. For details, refer to the G5 series USER'S MANUAL. Confirm the Manual No. that is listed in Related Manuals.

## Characteristics

### ● Servo Drives with 100 VAC Input Power for Single-phase input type

Item			R88D-KNA5L-ECT	R88D-KN01L-ECT	R88D-KN02L-ECT	R88D-KN04L-ECT
Continuous output current (rms)			1.2A	1.7A	2.5A	4.6A
Input power supply	Main circuit	Power supply capacity	0.4KVA	0.4KVA	0.5KVA	0.9KVA
		Power supply voltage	Single-phase 100 to 120 VAC (85 to 132 V) 50/60 Hz			
		Rated current	1.7A	2.6A	4.3A	7.6A
		Heat value*1	11W	16.6W	21W	25W
	Control circuit	Power supply voltage	Single-phase 100 to 120 VAC (85 to 132 V) 50/60 Hz			
		Heat value*1	4W	4W	4W	4W
Weight			Approx. 0.8kg	Approx. 0.8kg	Approx. 1.0kg	Approx. 1.6kg
Maximum applicable motor capacity			50W	100W	200W	400 W
Applicable Servomotor (R88M-)	3,000 r/min Servomotors	<b>INC</b>	K05030H	K10030L	K20030L	K40030L
		<b>ABS</b>	K05030T	K10030S	K20030S	K40030S
	2,000 r/min Servomotors	<b>ABS</b>	-	-	-	-
		<b>ABS</b>	-	-	-	-

\*1. The heat value is given for rated operation.

### ● Servo Drives with 200 VAC Input Power for Single-phase/Three-phase input type

Item			R88D-KN01H-ECT	R88D-KN02H-ECT	R88D-KN04H-ECT	R88D-KN08H-ECT	R88D-KN10H-ECT	R88D-KN15H-ECT
Continuous output current (rms)			1.2A	1.6A	2.6A	4.1A	5.9A	9.4A
Input power supply	Main circuit	Power supply capacity	0.5KVA	0.5KVA *1	0.9KVA	1.3KVA	1.8KVA	2.3KVA
		Power supply voltage	Single-phase or 3-phase 200 to 240 VAC (170 to 264 V) 50/60 Hz					
		Rated current	1.6/0.9A *1	2.4/1.3A *1	4.1/2.4A *1	6.6/3.6A *1	9.1/5.2A *1	14.2/8.1A *1
		Heat value*2	14.3/13.7W*1	23/19W *1	33/24W *1	30/35.5W *1	57/49W *1	104/93W*1
	Control circuit	Power supply voltage	Single-phase 200 to 240 VAC (170 to 264 V) 50/60 Hz					
		Heat value*2	4W	4W	4W	4W	7W	7W
Weight			Approx. 0.8kg	Approx. 0.8kg	Approx. 1.0kg	Approx. 1.6kg	Approx. 1.8kg	Approx. 1.8kg
Maximum applicable motor capacity			100W	200W	400W	750W	1kW	1.5kW
Applicable Servomotor (R88M-)	3,000 r/min Servomotors	<b>INC</b>	K05030H K10030H	K20030H	K40030H	K75030H	-	K1K030H K1K530H
		<b>ABS</b>	K05030T K10030T	K20030T	K40030T	K75030T	-	K1K030T K1K530T
	2,000 r/min Servomotors	<b>INC</b>	-	-	-	-	K1K020H	K1K520H
		<b>ABS</b>	-	-	-	-	K1K020T	K1K520T
	1,000 r/min Servomotors	<b>INC</b>	-	-	-	-	-	K90010H
		<b>ABS</b>	-	-	-	-	-	K90010T

\*1. The first value is for single-phase input power and the second value is for 3-phase input power.

\*2. The heat value is given for rated operation.

# AC Servomotor/Drive G5-series

## ● Servo Drives with 200 VAC Input Power for Three-phase input type

Item			R88D-KN20H-ECT	R88D-KN30H-ECT	R88D-KN50H-ECT	R88D-KN75H-ECT	R88D-KN150H-ECT	
Continuous output current (rms)			13.4A	18.7A	33.0A	44.0A	66.1A	
Input power supply	Main circuit	Power supply capacity	3.3KVA	4.5KVA	7.5KVA	11.0KVA	22.0KVA	
		Power supply voltage	3-phase 200 to 230 VAC (170 to 253 V) 50/60 Hz				3-phase 200 to 230 VAC (170 to 253V) 50/60Hz 280 to 325 VDC (238 to 357V)	
		Rated current	11.8A	15.1A	21.6A	32.0A	58.0A	
		Heat value *1	139W	108W	328W	381W	720W	
	Control circuit	Power supply voltage	Single-phase 200 to 230 VAC (170 to 253 V) 50/60 Hz				Single-phase 200 to 230 VAC (170 to 253V) 50/60Hz 280 to 325 VDC (238 to 357V)	
		Heat value *1	10W	13W	13W	15W	17W	
Weight			Approx. 2.7kg	Approx. 4.8kg	Approx. 4.8kg	Approx. 13.5kg	Approx. 21.0kg	
Maximum applicable motor capacity			2kW	3kW	5kW	7.5kW	15kW	
Applicable Servomotor (R88M-)	3,000 r/min Servomotors	<b>INC</b>	K2K030H	K3K030H	K4K030H K5K030H	-	-	
		<b>ABS</b>	K2K030T	K3K030T	K4K030T K5K030T	-	-	
	2,000 r/min, 1,500 r/min Servomotors	<b>INC</b>	K2K020H	K3K020H	K4K020H K5K020H	-	-	
		<b>ABS</b>	K2K020T	K3K020T	K4K020T K5K020T	K7K515T	K11K015T K15K015T	
	1,000 r/min Servomotors	<b>INC</b>	-	K2K010H	K3K010H	-	-	
		<b>ABS</b>	-	K2K010T	K3K010T K4K510T	K6K010T	-	

\*1. The heat value is given for rated operation.

## ● Servo Drives with 400 VAC Input Power for Three-phase input type

Item			R88D-KN06F-ECT	R88D-KN10F-ECT	R88D-KN15F-ECT	R88D-KN20F-ECT	R88D-KN30F-ECT	R88D-KN50F-ECT	R88D-KN75F-ECT	R88D-KN150F-ECT	
Continuous output current (rms)			1.5A	2.9A	4.7A	6.7A	9.4A	16.5A	22.0A	33.1A	
Input power supply	Main circuit	Power supply capacity	1.2KVA	1.8KVA	2.3KVA	3.8KVA	4.5KVA	6.0KVA	11.0KVA	22.0KVA	
		Power supply voltage	3-phase 380 to 480 VAC (323 to 528 V) 50/60 Hz								
		Rated current	2.1A	2.8A	4.7A	5.9A	7.6A	12.1A	16.0A	29.0A	
		Heat value*1	32.2W	48W	49W	65W	108W	200W	300W	590W	
	Control circuit	Power supply voltage	24 VDC (20.4 to 27.6 V)								
		Heat value*1	7W	7W	7W	10W	13W	13W	15W	22W	
Weight			Approx. 1.9kg	Approx. 1.9kg	Approx. 1.9kg	Approx. 2.7kg	Approx. 4.7kg	Approx. 4.7kg	Approx. 13.5kg	Approx. 21.0kg	
Maximum applicable motor capacity			600W	1kW	1.5kW	2kW	3kW	5kW	7.5kW	15kW	
Applicable Servomotor (R88M-)	3,000 r/min Servomotors	<b>INC</b>	-	K75030F	K1K030F K1K530F	K2K030F	K3K030F	K4K030F K5K030F	-	-	
		<b>ABS</b>	-	K75030C	K1K030C K1K530C	K2K030C	K3K030C	K4K030C K5K030C	-	-	
	2,000 r/min, 1,500 r/min Servomotors	<b>INC</b>	K40020F K60020F	K1K020F	K1K520F	K2K020F	K3K020F	K4K020F K5K020F	-	-	
		<b>ABS</b>	K40020C K60020C	K1K020C	K1K520C	K2K020C	K3K020C	K4K020C K5K020C	K7K515C	K11K015C K15K015C	
	1,000 r/min Servomotors	<b>INC</b>	-	-	K90010F	-	K2K010F	K3K010F	-	-	
		<b>ABS</b>	-	-	K90010C	-	K2K010C	K3K010C K4K510C	K6K010C	-	

\*1. The heat value is given for rated operation.

## EtherCAT Communications Specifications

Item	Specification
<b>Communications standard</b>	IEC 61158 Type 12, IEC 61800-7 CiA 402 Drive Profile
<b>Physical layer</b>	100BASE-TX (IEEE802.3)
<b>Connectors</b>	RJ45 × 2 (shielded) ECAT IN: EtherCAT input ECAT OUT: EtherCAT output
<b>Communications media</b>	Ethernet Category 5 (100BASE-TX) or higher (twisted-pair cable with double, aluminum tape and braided shielding) is recommended.
<b>Communications distance</b>	Distance between nodes: 100 m max.
<b>Process data</b>	Fixed PDO mapping
<b>Mailbox (CoE)</b>	Emergency messages, SDO requests, SDO responses, and SDO information
<b>Distributed clock (DC)</b>	Synchronization in DC mode. DC cycle: 250 μs, 500 μs, 1 ms, 2 ms, 4 ms
<b>LED indicators</b>	L/A IN (Link/Activity IN) × 1 L/A OUT (Link/Activity OUT) × 1 RUN × 1 ERR × 1
<b>CiA402 Drive Profile</b>	<ul style="list-style-type: none"> <li>• Cyclic synchronous position mode</li> <li>• Cyclic synchronous velocity mode</li> <li>• Cyclic synchronous torque mode</li> <li>• Profile position mode</li> <li>• Homing mode</li> <li>• Touch probe function (Latch function)</li> <li>• Torque limit function</li> </ul>

## Version Information

### Unit Versions

Unit	Model	Unit version		
		Unit version 1.0	Unit version 2.0	Unit version 2.1
AC Servo Drives G5-Series built-in EtherCAT Communications	R88D-KN□-ECT-R *1	Supported		
	R88D-KN□-ECT		Supported	Supported
Sysmac Studio version (At the time of the controller NJ series and connection)		Version 1.00 or higher *2	Version 1.00 or higher *3	Version 1.00 or higher
Sysmac Studio support version (At the time of the controller NX series and connection)		Ver. 1.13 or higher *2	Ver. 1.13 or higher *3	Ver. 1.13 or higher
Compatible CX-Drive version		Version 2.2 or higher	Version 2.3 or higher	Version 2.4 or higher

\*1. Production was discontinued.

\*2. The function that was enhanced by the upgrade for Unit version 2.0 can not be used. For detail, refer to "Function Support by Unit Version".

\*3. The function that was enhanced by the upgrade for Unit version 2.1 can not be used. For detail, refer to "Function Support by Unit Version".

### Function Support by Unit Version

Unit		AC Servo Drives G5-Series built-in EtherCAT Communications		
Model		R88D-KN□-ECT-R *1	R88D-KN□-ECT	
Unit version		Unit version 1.0	Unit version 2.0	Unit version 2.1
<b>Sysmac Products Features</b>	<b>Sysmac Error Status</b>	No supported		Supported
	<b>Saving the Node Address Setting</b>	No supported		Supported
	<b>Serial Number Display *2</b>	No supported		Supported
	<b>ESI Specification (Version 1.0)</b>	No supported		Supported
	<b>SII Data Check</b>	No supported		Supported
<b>Fixed PDO mapping</b>		No supported	Supported	
<b>Variable PDO mapping (1600 hex, 1A00 hex)</b>		No supported		Supported
<b>Available operation modes</b>	<b>csp: Cyclic synchronous position mode</b>	Supported		
	<b>csv: Cyclic synchronous velocity mode</b>	No supported	Supported	
	<b>cst: Cyclic synchronous torque mode</b>	No supported	Supported	
	<b>pp: Profile position mode</b>	No supported		Supported
	<b>hm: Homing mode</b>	No supported	Supported	
<b>FIR filter function</b>		No supported	Supported *3 (Available when the communications cycle is 1 ms or above)	
<b>Error detection function</b>	<b>Excessive Speed Deviation Error</b>	No supported	Supported	
	<b>Interruptions Error</b>	No supported	Supported	
<b>Electronic gear function</b>		Supported	No supported *4 (only to 1:1)	Supported

# AC Servomotor/Drive G5-series

Unit		AC Servo Drives G5-Series built-in EtherCAT Communications		
Model		R88D-KN□-ECT-R *1	R88D-KN□-ECT	
Unit version		Unit version 1.0	Unit version 2.0	Unit version 2.1
Item				
Fully-closed Control *5		Supported	Available when the communications cycle is 500 μs or above in csp and 1 ms or above in hm.	Available when the communications cycle is 1 ms or above at an electronic gear ratio of 1:1 and 2 ms or above at a gear ratio other than 1:1. *6
Torque limit objects		PDO mapping to 60E0/60E1 hex is not possible.	PDO mapping to 60E0/60E1 hex is possible. *7	
Positioning Completion Range		No supported		Supported
Reference Position for CSP (4020 hex)		No supported		Supported
Data Setting Warning Detection Setting (3781)		No supported		Supported *8
Version indication on the unit label		No supported	Supported	

\*1. Production was discontinued.

\*2. The function to show the serial number controlled by OMRON in 1018h-04 hex.

\*3. Setting the communications cycle to 500 μs or less does not enable the FIR filter function, although doing so does not cause any error.

\*4. Setting this to an electronic gear ratio other than 1:1 simply causes the G5-series AC Servo Drive to operate at 1:1 without any errors.

\*5. If Fully-closed Control is not available, a Function Setting Error (Error No. 93.4) will occur.

\*6. This is applicable only when the total size of the objects mapped to RxPDO is 12 bytes or less. For details, refer to the USER'S MANUAL.

\*7. There are objects added (3013 hex/3522 hex) to or renamed (3525 hex/3526 hex) from unit version 1.0.

For details of these objects, refer to Torque Limit Selection (3521 hex) in Extended Objects of each manual.

\*8. Only the following Servo Drive models support DC power input:

- R88D-KN75H-ECT • R88D-KN150H-ECT

## Components and Functions

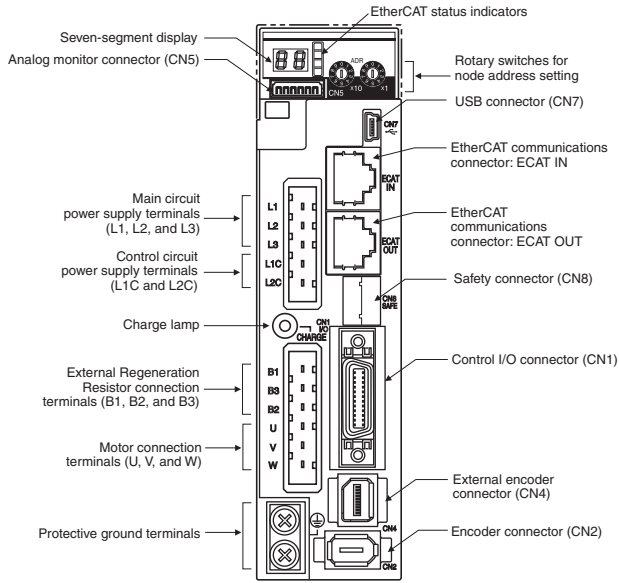

### Display

A 2-digit 7-segment display shows the node address, error codes, and other Servo Drive status.

### Charge Lamp

Lights when the main circuit power supply is turned ON.

### EtherCAT Status Indicators

These indicators show the status of EtherCAT communications. For details, refer to the G5 series USER'S MANUAL (Cat.No.I576).

### Control I/O Connector (CN1)

Used for command input signals and I/O signals.

### Encoder Connector (CN2)

Connector for the encoder installed in the Servomotor.

### External Encoder Connector (CN4)\*

Connector for an encoder signal used during fully-closed control.

### EtherCAT Communications Connectors (ECAT IN and ECAT OUT)

These connectors are for EtherCAT communications.

### Analog Monitor Connector (CN5)

You can use a special cable to monitor values, such as the motor rotation speed, torque command value, etc.

### USB Connector (CN7)

Communications connector for the computer.

### Safety Connector (CN8)

Connector for safety devices.

If no safety devices are used, keep the factory-set safety bypass connector installed.

# AC Servomotor/Drive G5-series

## \*External Encoder

Contact the encoder manufacturer to find out the detailed specifications such as operating environment before use.

External encoder type	Maker	Example of External encoder	Supported speed *1	Resolution *4 [μm]	Maximum speed *4 [m/s]
90° phase difference output type *2 *3	–	Phase A/B type	0 to 4 Mpps (Multiplication × 4)	–	–
Serial communications type (Incremental type) *3	Magnescale Co., Ltd	SL700+PL101RP/RHP SL710+PL101RP/RHP	0 to 400 Mpps	0.1	10
		SR75/SR85		0.01 to 1	3.3
		BF1		0.001/0.01	0.4/1.8
		SQ10+PQ11 SQ10+PQ10+MQ10		0.05/0.1/0.5/1	3
	NIDEC SANKYO CORPORATION	PSLH041+PSLG		0.1	6
Serial communications type (Absolute type) *3	HEIDENHAIN CORPORATION	LIC2197P/LIC2199P	0 to 400 Mpps	0.05/0.1	10
		LIC4193P/LIC4195P LIC4197P/LIC4199P		0.001/0.005/ 0.01	0.4/2/4
		LC195P/LC495P		0.001/0.01	3
	FAGOR AUTOMATION	SAP/SVAP/GAP		0.05	2.5
		S2AP/SV2AP/G2AP		0.01/0.05	3
		LAP		0.05/0.1	2
	Magnescale Co., Ltd	SR77/SR87		0.01 to 1	3.3
	Mitutoyo Corporation	AT573□		0.05	2.5
		ST77□□		0.1	5
		ST137□□		0.001/0.01	8
	Renishaw Co.	RESOLUTE		0.001	0.4
				0.05	20
					0.1

\*1. The supported speed is the internal feedback pulse speed [external encoder pulse/s] of the external encoder that can be processed by the Servo Drive.

Check the instruction manual of the external encoder for the speed range supported by your external encoder.

\*2. These are the directions that the Drive counts a 90° phase difference output.

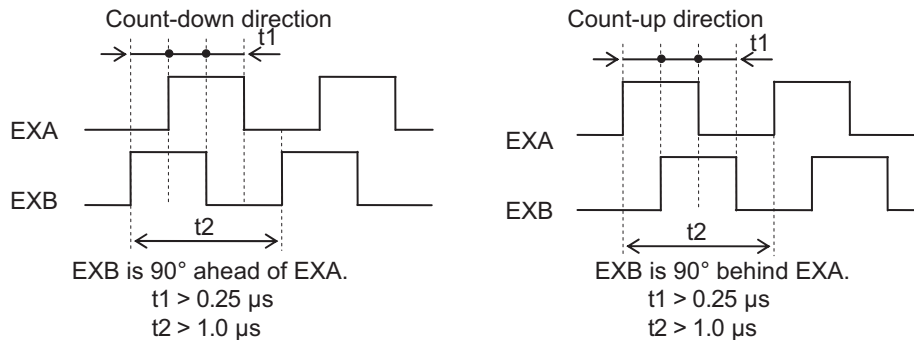

\*3. For the external encoder connection direction, set the direction so that count-up occurs when the motor shaft is rotating counterclockwise, and count-down occurs when the motor shaft is rotating clockwise. If the connection direction cannot be selected due to installation conditions or any other reason, the count direction can be reversed using External Feedback Pulse Direction Switching (3326 hex).

\*4. The resolution and maximum speed are the values for the G5-series Servo Drive. The resolution and maximum speed may be different from the specifications of the feedback encoder due to restriction on the maximum pulse frequency of the Servo Drive.

## Dimensions

### <Wall Mounting>

Single-phase 100 VAC R88D-KNA5L-ECT/-KN01L-ECT (50 to 100 W)  
R88D-KN01L-ECT-L (100 W)

Single-phase/Three-phase 200 VAC R88D-KN01H-ECT/-KN02H-ECT (100 to 200 W)  
R88D-KN01H-ECT-L/-KN02H-ECT-L (100 to 200 W)

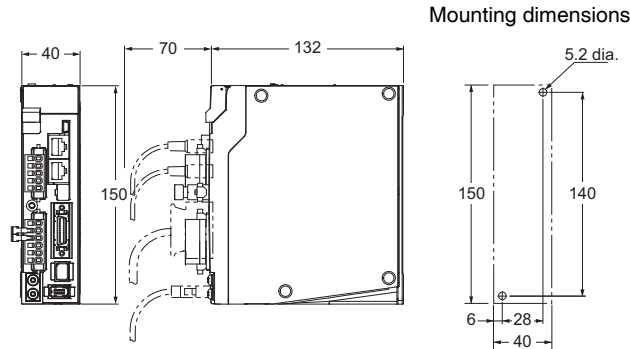

Single-phase 100 VAC R88D-KN02L-ECT (200 W)  
R88D-KN02L-ECT-L (200 W)

Single-phase/Three-phase 200 VAC R88D-KN04H-ECT (400 W)  
R88D-KN04H-ECT-L (400 W)

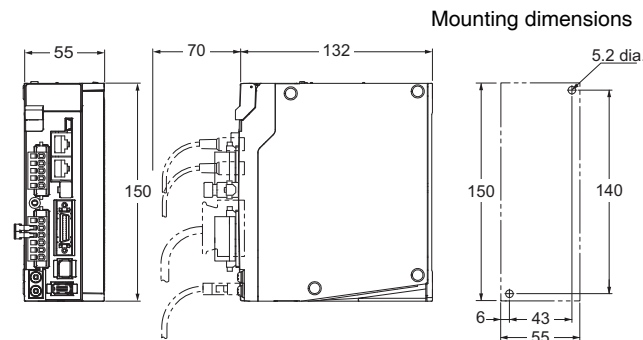

Single-phase 100 VAC R88D-KN04L-ECT (400 W)  
R88D-KN04L-ECT-L (400 W)

Single-phase/Three-phase 200 VAC R88D-KN08H-ECT (750 W)  
R88D-KN08H-ECT-L (750 W)

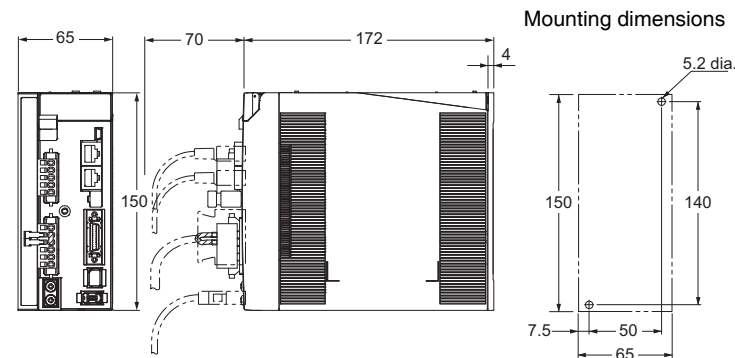

**Note:** R88D-KN□-ECT-L is the AC Servo Drives with Built-in EtherCAT Communications type.

Single-phase/Three-phase 200 VAC R88D-KN10H-ECT/-KN15H-ECT (900 W to 1.5 kW)  
R88D-KN10H-ECT-L/-KN15H-ECT-L (1 kW to 1.5 kW)

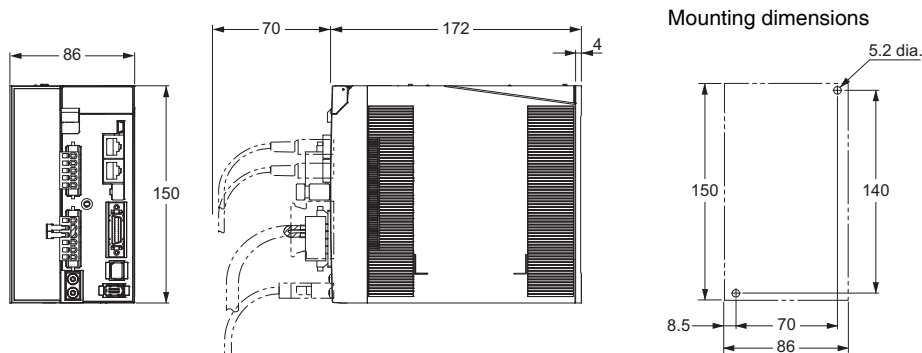

Three-phase 200 VAC R88D-KN20H-ECT (2 kW)

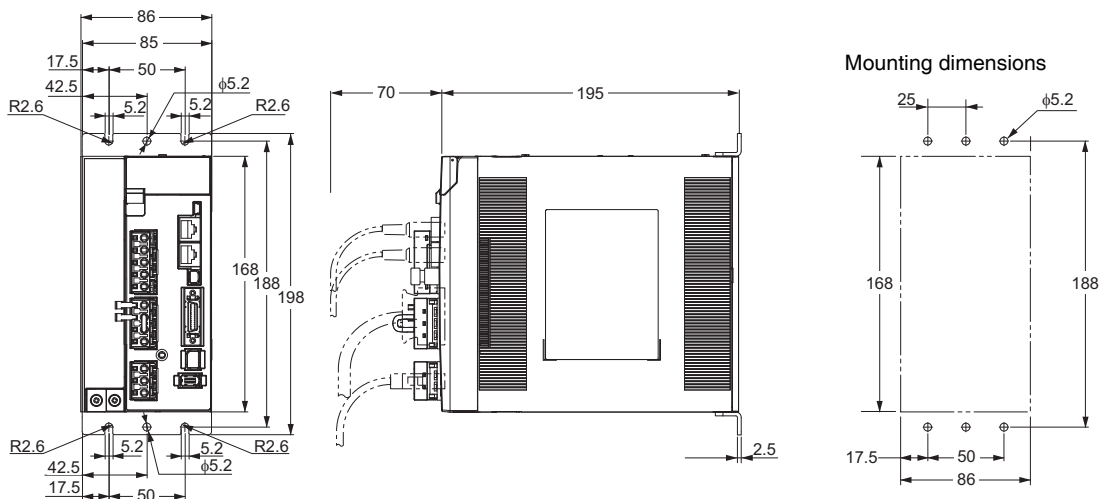

Three-phase 200 VAC R88D-KN30H-ECT/-KN50H-ECT (3 to 5 kW)

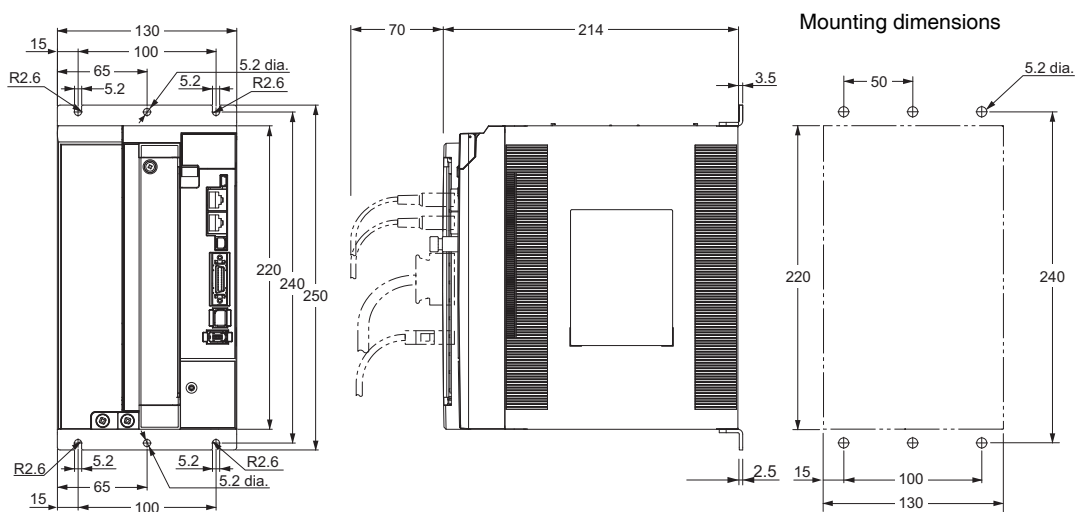





Three-phase 200 VAC R88D-KN75H-ECT (7.5 kW)

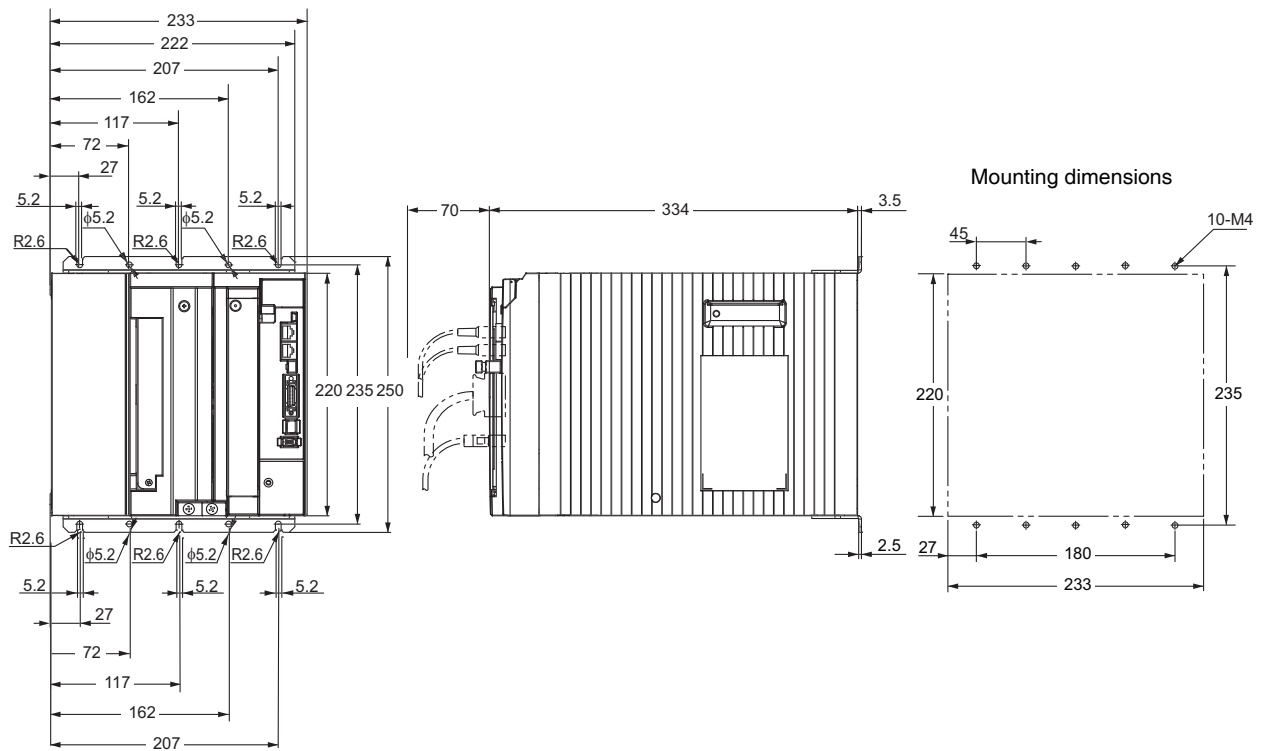

Three-phase 400 VAC R88D-KN150F-ECT (15kW)

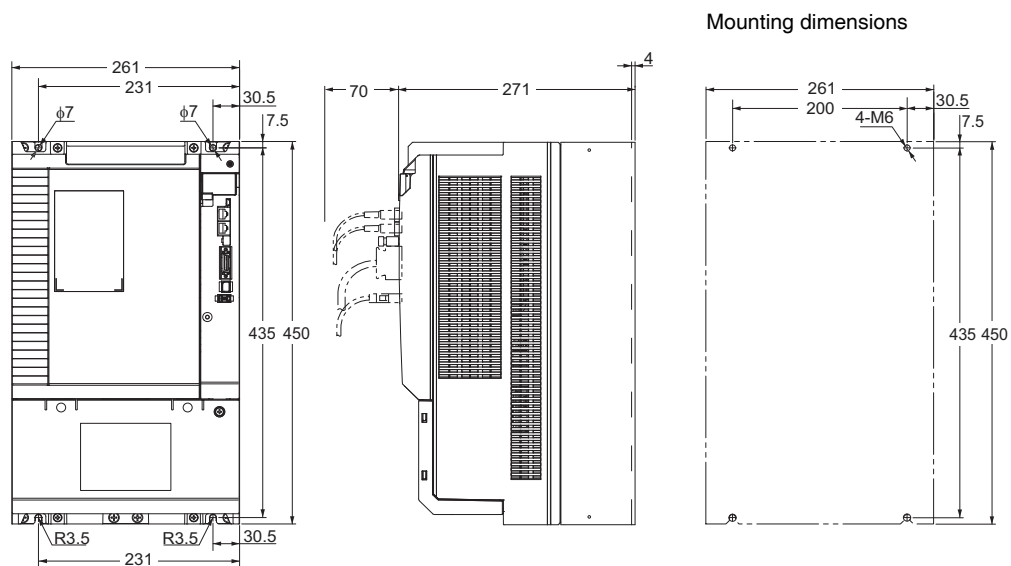

G5-Series  
System Configuration

EtherCAT Communications  
AC Servo Drive

EtherCAT Communications  
Linear Motor Type  
AC Servo Drive

General-purpose Inputs  
AC Servo Drive

ML-II Type  
AC Servo Drive

AC Servomotors

Linear Motor

Decelerator

# G5-series AC Servo Drives with Built-in EtherCAT Communications Linear Motor Type

# R88D-KN□-ECT-L

## Contents



- Ordering Information
- Specifications
  - General Specifications
  - Characteristics
    - Servo Drives with 100 VAC Input Power
    - Servo Drives with 200 VAC Input Power
    - Servo Drives with 400 VAC Input Power
  - EtherCAT Communication Specifications
- Version Information
- Names and Functions
  - Servo Drive Part Names
  - Functions
- Dimensions

## Ordering Information

Refer to the Ordering Information.

## Specifications

### General Specifications

Item	Specifications	
Ambient operating temperature and humidity	0 to 55°C, 20% to 85% max. (with no condensation)	
Storage ambient temperature and humidity	-20 to 65°C, 20% to 85% max. (with no condensation)	
Operating and storage atmosphere	No corrosive gases	
Vibration resistance	10 to 60 Hz and at an acceleration of 5.88 m/s <sup>2</sup> or less (Not to be run continuously at the resonance point)	
Insulation resistance	Between power supply terminals/power terminals and FG terminal: 0.5 MΩ min. (at 500 VDC)	
Dielectric strength	Between power supply/power terminals and FG terminal: 1,500 VAC for 1 min at 50/60 Hz	
Protective structure	Built into panel	
EC Directives*	EMC Directive	EN 55011, EN 61000-6-2, EN 61800-3
	Low Voltage Directive	EN 61800-5-1
	Machinery Directives	EN954-1(Cat.3), EN ISO13849-1 (Cat.3)(PLc, d), ISO13849-1(Cat.3)(PLc, d), EN61508(SIL2), EN62061(SIL2), EN61800-5-2 (STO), IEC61326-3-1 (SIL 2)
UL standards	UL 508C	
CSA standards	CSA C22.2 No.14	
Korean Radio Regulations (KC)	Certified	

\* The certification from third party is issued in combination with the revolution type motor. The conformance as the whole system should be checked by machine builder.

- Note: 1.** The above items reflect individual evaluation testing. The results may differ under compound conditions.
- Note: 2.** Always disconnect all connections to the Servo Drive before you perform insulation resistance tests on it. If you perform an insulation resistance test while the Servo Drive is connected, the Servo Drive may be damaged. Never perform dielectric strength tests on the Servo Drive. Failure to follow this precaution may result in damaging internal elements.
- Note: 3.** Some Servo Drive parts will require maintenance. For details, refer to the G5 series USER'S MANUAL. Confirm the Manual No. that is listed in Related Manuals.
- Note: 4.** Vibration, unstable movement, or acoustic noise may occur by an exogenous noise. In such case, please reduce incoming noise as referred in G5 series user's manuals.

## Characteristics

### ● 100-VAC Input Models for Single-phase input type

Item			R88D-KN01L-ECT-L	R88D-KN02L-ECT-L	R88D-KN04L-ECT-L
Input power supply	Main circuit	Power supply capacity	0.4 KVA	0.5 KVA	0.9 KVA
		Power supply voltage	Single-phase 100 to 120 VAC (85 to 132 VAC) 50/60 Hz		
		Rated current	2.6 A	4.3 A	7.6 A
		Heat value*1	16.6 W	21 W	25 W
	Control circuit	Power supply voltage	Single-phase 100 to 120 VAC (85 to 132 VAC) 50/60 Hz		
		Heat value*1	4 W	4 W	4 W
Mass			Approx. 0.8 kg	Approx. 1.0 kg	Approx. 1.6 kg
Maximum motor capacity	Motor Rated Rms Current		1.7 Arms	2.5 Arms	4.6 Arms
	Maximum current of motor		5.1 Arms	7.5 Arms	13.8 Arms

\*1. The heat value is given for rated operation.

### ● 200-VAC Input Models for Single-phase/Three-phase input type

Item			R88D-KN01H-ECT-L	R88D-KN02H-ECT-L	R88D-KN04H-ECT-L	R88D-KN08H-ECT-L	R88D-KN10H-ECT-L	R88D-KN15H-ECT-L
Input power supply	Main circuit	Power supply capacity	0.5 KVA	0.5 KVA	0.9 KVA	1.3 KVA	1.8 KVA	2.3 KVA
		Power supply voltage	Single-phase or 3-phase 200 to 240 VAC (170 to 264 VAC) 50/60 Hz					
		Rated current	1.6/0.9 A*1	2.4/1.3 A*1	4.1/2.4 A*1	6.6/3.6 A*1	9.1/5.2 A*1	14.2/8.1 A*1
		Heat value*2	14.3/13.7 W*1	23/19 W*1	33/24 W*1	30/35.5 W*1	57/49 W*1	104/93 W*1
	Control circuit	Power supply voltage	Single-phase 200 to 240 VAC (170 to 264 VAC) 50/60 Hz					
		Heat value*2	4 W	4 W	4 W	4 W	7 W	7 W
Mass			Approx. 0.8 kg	Approx. 0.8 kg	Approx. 1.0 kg	Approx. 1.6 kg	Approx. 1.8 kg	Approx. 1.8 kg
Maximum motor capacity	Rated effective current of motor		1.2 Arms	1.6 Arms	2.6 Arms	4.1 Arms	5.9 Arms	9.4 Arms
	Maximum current of motor		3.6 Arms	4.8 Arms	7.8 Arms	12.3 Arms	16.9 Arms	28.2 Arms

\*1. The first value is for single-phase input power and the second value is for 3-phase input power.

\*2. The heat value is given for rated operation.

### ● 400-VAC Input Models for Three-phase input type

Item			R88D-KN06F-ECT-L	R88D-KN10F-ECT-L	R88D-KN15F-ECT-L	R88D-KN20F-ECT-L	R88D-KN30F-ECT-L
Input power supply	Main circuit	Power supply capacity	1.2 KVA	1.8 KVA	2.3 KVA	3.8 KVA	4.5 KVA
		Power supply voltage	3-phase 380 to 480 VAC (323 to 528 VAC) 50/60 Hz				
		Rated current	2.1 A	2.8 A	3.9 A	5.9 A	7.6 A
		Heat value*1	32.2 W	48 W	49 W	65 W	108 W
	Control circuit	Power supply voltage	24 VDC (20.4 to 27.6 VAC)				
		Heat value*1	7 W	7 W	7W	10 W	13 W
Mass			Approx. 1.9 kg	Approx. 1.9 kg	Approx. 1.9 kg	Approx. 2.7 kg	Approx. 4.7 kg
Maximum motor capacity	Rated effective current of motor		1.5 Arms	2.9 Arms	4.7 Arms	6.7 Arms	9.4 Arms
	Maximum current of motor		4.5 Arms	8.7 Arms	14.1 Arms	19.7 Arms	28.2 Arms

\*1. The heat value is given for rated operation.

## EtherCAT Communications Specifications

Item	Specification
<b>Communications standard</b>	IEC 61158 Type 12, IEC 61800-7 CiA 402 Drive Profile
<b>Physical layer</b>	100BASE-TX (IEEE802.3)
<b>Connectors</b>	RJ45 × 2 (shielded) ECAT IN: EtherCAT input ECAT OUT: EtherCAT output
<b>Communications media</b>	Ethernet Category 5 (100BASE-TX) or higher (twisted-pair cable with double, aluminum tape and braided shielding) is recommended.
<b>Communications distance</b>	Distance between nodes: 100 m max.
<b>Process data</b>	Fixed PDO mapping
<b>Mailbox (CoE)</b>	Emergency messages, SDO requests, SDO responses, and SDO information
<b>Distributed clock (DC)</b>	Synchronization in DC mode. DC cycle: 250 μs, 500 μs, 1 ms, 2 ms, 4 ms
<b>LED indicators</b>	L/A IN (Link/Activity IN) × 1 L/A OUT (Link/Activity OUT) × 1 RUN × 1 ERR × 1
<b>CiA402 Drive Profile</b>	<ul style="list-style-type: none"> <li>• Cyclic synchronous position mode</li> <li>• Cyclic synchronous velocity mode</li> <li>• Cyclic synchronous torque mode</li> <li>• Profile position mode</li> <li>• Homing mode</li> <li>• Touch probe function (Latch function)</li> <li>• Torque limit function</li> </ul>

## Version Information

### Unit Versions

#### ● AC Servo Drives with built-in EtherCAT communications Linear motor type and Software

Unit	Model	Unit version
		Unit version 1.1
AC Servo Drives G5-Series built-in EtherCAT Communications Linear Motor Type	<b>R88D-KN□□□-ECT-L</b>	Supported
Compatible Sysmac Studio version (At the time of the controller NJ series and connection)		Version 1.04 or higher
Sysmac Studio support version (At the time of the controller NJ series and At the time of the controller NJ series and connection )		Ver.1.13

# Components and Functions

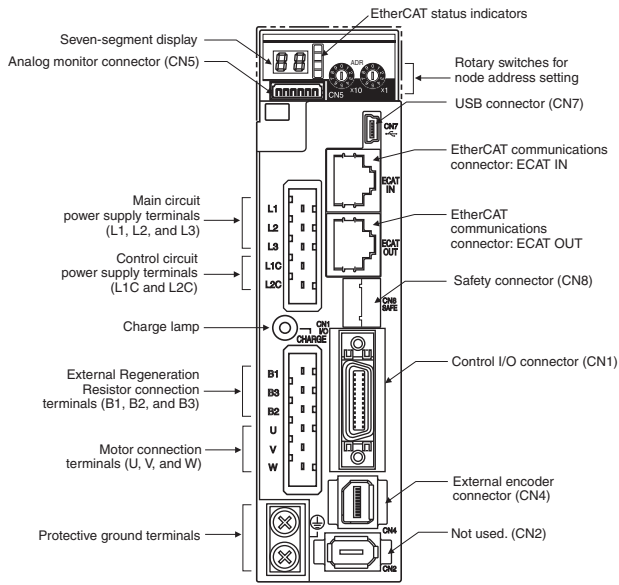

### Display

A 2-digit 7-segment display shows the node address, error codes, and other Servo Drive status.

### Charge Lamp

Lights when the main circuit power supply is turned ON.

### EtherCAT Status Indicators

These indicators show the status of EtherCAT communications. For details, refer to the G5 series USER'S MANUAL (Cat.No.I576).

### Control I/O Connector (CN1)

Used for command input signals and I/O signals.

### External Encoder Connector (CN4)\*

Connector for an encoder signal used during fully-closed control.

### EtherCAT Communications Connectors (ECAT IN and ECAT OUT)

These connectors are for EtherCAT communications.

### Analog Monitor Connector (CN5)

You can use a special cable to monitor values, such as the motor rotation speed, torque command value, etc.

### USB Connector (CN7)

Communications connector for the computer.

### Safety Connector (CN8)

Connector for safety devices.

If no safety devices are used, keep the factory-set safety bypass connector installed.

G5-Series  
System Configuration

EtherCAT Communications  
AC Servo Drive

EtherCAT Communications  
Linear Motor Type  
AC Servo Drive

General-purpose Inputs  
AC Servo Drive

ML-II Type  
AC Servo Drive

AC Servomotors

Linear Motor

Decelerator

# AC Servomotor/Drive G5-series

## \*External Encoder

Contact the encoder manufacturer to find out the detailed specifications such as operating environment before use.

External encoder type	Maker	Example of External encoder	Supported speed *1	Resolution *4 [μm]	Maximum speed *4 [m/s]
90° phase difference output type *2 *3	–	Phase A/B type	0 to 4 Mpps (Multiplication × 4)	–	–
Serial communications type (Incremental type) *3	Magnescale Co., Ltd	SL700+PL101RP/RHP SL710+PL101RP/RHP	0 to 400 Mpps	0.1	10
		SR75/SR85		0.01 to 1	3.3
		BF1		0.001/0.01	0.4/1.8
		SQ10+PQ11 SQ10+PQ10+MQ10		0.05/0.1/0.5/ 1	3
	NIDEC SANKYO CORPORATION	PSLH041+PSLG		0.1	6
Serial communications type (Absolute type) *3	HEIDENHAIN CORPORATION	LIC2197P/LIC2199P	0 to 400 Mpps	0.05/0.1	10
		LIC4193P/LIC4195P LIC4197P/LIC4199P		0.001/0.005/ 0.01	0.4/2/4
		LC195P/LC495P		0.001/0.01	3
	FAGOR AUTOMATION	SAP/SVAP/GAP		0.05	2.5
		S2AP/SV2AP/G2AP		0.01/0.05	3
	Magnescale Co., Ltd	LAP		0.05/0.1	2
		SR77/SR87		0.01 to 1	3.3
	Mitutoyo Corporation	AT573□		0.05	2.5
		ST77□□		0.1	5
		ST137□□		0.001/0.01	8
	Renishaw Co.	RESOLUTE		0.001	0.4
				0.05	20
				0.1	40

\*1. The supported speed is the internal feedback pulse speed [external encoder pulse/s] of the external encoder that can be processed by the Servo Drive.

Check the instruction manual of the external encoder for the speed range supported by your external encoder.

\*2. These are the directions that the Drive counts a 90° phase difference output.

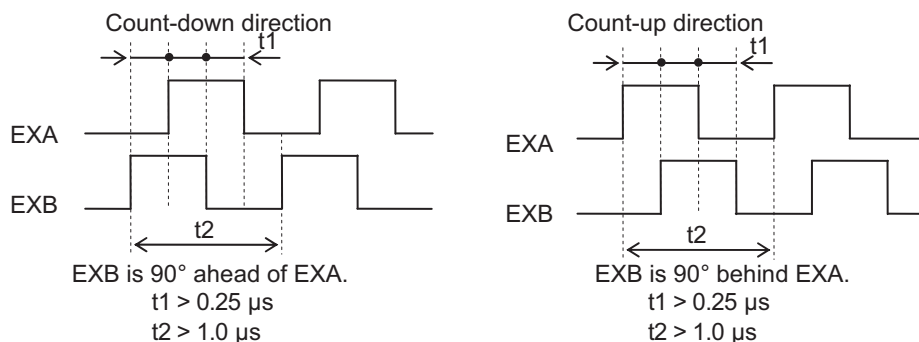

\*3. For the external encoder connection direction, set the direction so that count-up occurs when the Motor Coil Unit moves in the direction of the connected cable, and count-down occurs when the Motor Coil Unit moves in the opposite direction. If the connection direction cannot be selected due to installation conditions or any other reason, the count direction can be reversed using External Feedback Pulse Direction Switching (3326 hex).

\*4. The resolution and maximum speed are the values for the G5-series Servo Drive. The resolution and maximum speed may be different from the specifications of the feedback encoder due to restriction on the maximum pulse frequency of the Servo Drive.

## Dimensions

Refer to the page of Dimensions of the built-in EtherCAT communication type.

# G5-Series AC Servo Drives with General-purpose Pulse Train or Analog Inputs

# R88D-KT

## Contents

- Ordering Information
- Specifications
  - General Specifications
  - Characteristics
    - Servo Drives with Single-phase 100 VAC Input Power
    - Servo Drives with Single-phase or three-phase 200 VAC Input Power
    - Servo Drives with Three-phase 200 VAC Input Power
    - Servo Drives with 400 VAC Input Power
- Names and Functions
  - Servo Drive Part Names
  - Functions
- Dimensions



## Ordering Information

Refer to the Ordering Information.

## Specifications

### General Specifications

Item		Specifications	
Ambient operating temperature and humidity		0 to 55°C, 85% max. (with no condensation)	
Storage ambient temperature and humidity		-20 to 65°C, 85% max. (with no condensation)	
Operating and storage atmosphere		No corrosive gases	
Vibration resistance		10 to 60 Hz and at an acceleration of 5.88 m/s <sup>2</sup> or less (Not to be run continuously at the resonance point)	
Insulation resistance		Between power supply terminal/power terminal and FG terminal: 0.5 MΩ min. (at 500 VDC Megger)	
Dielectric strength		Between power supply/power line terminals and FG terminal: 1,500 VAC for 1 min at 50/60 Hz	
Protective structure		Built into panel	
International standard	EC directives	EMC directive	EN55011, EN61000-6-2, IEC61800-3
		Low voltage command	EN61800-5-1
		Machinery directives	EN954-1 (Cat.3), EN ISO 13849-1: 2008 (PLC,d), ISO 13849-1: 2006 (PLC,d), EN61508 (SIL2), EN62061 (SIL2), EN61800-5-2 (STO), IEC61326-3-1 (SIL2)
	UL standards	UL508C *	
	CSA standards	CSA C22.2 No.14	
Korean Radio Regulations (KC)		Certified	

\* The Servo drive of R88D-KT20□ and smaller capacity the one are UL-Listed.

The Servo drive of R88D-KT30□ and bigger capacity the one are UL-Recognized.

**Note: 1.** The above items reflect individual evaluation testing. The results may differ under compound conditions.

**Note: 2.** Always disconnect all connections to the Servo Drive before you perform insulation resistance tests on it. If you perform an insulation resistance test while the Servo Drive is connected, the Servo Drive may be damaged. Never perform dielectric strength tests on the Servo Drive. Failure to follow this precaution may result in damaging internal elements.

**Note: 3.** Some Servo Drive parts will require maintenance. For details, refer to the G5 series USER'S MANUAL. Confirm the Manual No. that is listed in Related Manuals.

**Note: 4.** To conform EMC directive, the tips on wiring and installation written in the G5 series user's manual must be followed. Confirm the Manual No. that is listed in Related Manuals.

## Characteristics

### ● Servo Drives with 100 VAC Input Power for Single-phase input type

Item			R88D-KTA5L	R88D-KT01L	R88D-KT02L	R88D-KT04L
Continuous output current (rms)			1.2A	1.7A	2.5A	4.6A
Input power supply	Main circuit	Power supply capacity	0.4KVA	0.4KVA	0.5KVA	0.9KVA
		Power supply voltage	Single-phase 100 to 115 VAC (85 to 127 V), 50/60 Hz			
		Rated current	1.7A	2.6A	4.3A	7.6A
		Heat value*1	11W	16.6W	21W	25W
	Control circuit	Power supply voltage	Single-phase 100 to 120 VAC (85 to 132 V), 50/60 Hz			
		Heat value*1	4W	4W	4W	4W
Weight			Approx. 0.8 kg	Approx. 0.8kg	Approx. 1.0kg	Approx. 1.6kg
Maximum applicable motor capacity			50W	100W	200W	400W
Applicable Servomotors (R88M-)	3,000 r/min Servomotors	<b>INC</b>	K05030H	K10030L	K20030L	K40030L
		<b>ABS</b>	K05030T	K10030S	K20030S	K40030S
	2,000 r/min Servomotors	<b>ABS</b>	-	-	-	-
		<b>ABS</b>	-	-	-	-

\*1. The heat value is given for rated operation.

### ● Servo Drives with 200 VAC Input Power for Single-phase/Three-phase input type

Item			R88D-KT01H	R88D-KT02H	R88D-KT04H	R88D-KT08H	R88D-KT10H	R88D-KT15H
Continuous output current (rms)			1.2A	1.6A	2.6A	4.1A	5.9A	9.4A
Input power supply	Main circuit	Power supply capacity	0.5KVA	0.5KVA	0.9KVA	1.3KVA	1.8KVA	2.3KVA
		Power supply voltage	Single-phase or Three-phase 200 to 240 VAC (170 to 264 V), 50/60 Hz					
		Rated current	1.6/0.9A*1	2.4/1.3A *1	4.1/2.4A *1	6.6/3.6A *1	9.1/5.2A *1	14.2/8.1A *1
		Heat value*2	14.3/13.7W*1	23/19W*1	33/24W*1	30/35.5W*1	57/49W*1	104/93W*1
	Control circuit	Power supply voltage	Single-phase 200 to 240VAC (170 to 264V), 50/60Hz					
		Heat value*2	4W	4W	4W	4W	7W	7W
Weight			Approx. 0.8kg	Approx. 0.8kg	Approx. 1.1kg	Approx. 1.6kg	Approx. 1.8kg	Approx. 1.8kg
Maximum applicable motor capacity			100W	200W	400W	750W	1kW	1.5kW
Applicable Servomotors (R88M-)	3,000 r/min Servomotors	<b>INC</b>	K05030H K10030H	K20030H	K40030H	K75030H	-	K1K030H K1K530H
		<b>ABS</b>	K05030T K10030T	K20030T	K40030T	K75030T	-	K1K030T K1K530T
	2,000 r/min Servomotors	<b>INC</b>	-	-	-	-	K1K020H	K1K520H
		<b>ABS</b>	-	-	-	-	K1K020T	K1K520T
	1,000 r/min Servomotors	<b>INC</b>	-	-	-	-	-	K90010H
		<b>ABS</b>	-	-	-	-	-	K90010T

\*1. The left value is for single-phase input power and the right value is for three-phase input power.

\*2. The heat value is given for rated operation.

● Servo Drives with 200 VAC Input Power  
for Three-phase input type

Item			R88D-KT20H	R88D-KT30H	R88D-KT50H	R88D-KT75H	R88D-KT150H	
Continuous output current (rms)			13.4A	18.7A	33.0A	44.0A	66.1A	
Input power supply	Main circuit	Power supply capacity	3.3KVA	4.5KVA	7.5KVA	11.0KVA	22.0KVA	
		Power supply voltage	3-phase 200 to 230 VAC (170 to 253 V), 50/60 Hz				3-phase 200 to 230 VAC (170 to 253V) 50/60Hz 280 to 325 VDC (238 to 357V)	
		Rated current	11.8A	15.1A	21.6A	32.0A	58.0A	
		Heat value*1	139W	108W	328W	381W	720W	
	Control circuit	Power supply voltage	Single-phase 200 to 230 VAC (170 to 253 V), 50/60 Hz				Single-phase 200 to 230 VAC (170 to 253V) 50/60Hz 280 to 325 VDC (238 to 357V)	
		Heat value*1	10W	13W	13W	15W	17W	
Weight			Approx. 2.7kg	Approx. 4.8kg	Approx. 4.8kg	Approx. 13.5kg	Approx. 21.0kg	
Maximum applicable motor capacity			2kW	3kW	5kW	7.5kW	15kW	
Applicable Servomotors (R88M-)	3,000 r/min Servomotors	INC	K2K030H	K3K030H	K4K030H K5K030H	-	-	
		ABS	K2K030T	K3K030T	K4K030T K5K030T	-	-	
	2,000 r/min, 1,500 r/min Servomotors	INC	K2K020H	K3K020H	K4K020H K5K020H	-	-	
		ABS	K2K020T	K3K020T	K4K020T K5K020T	K7K515T	K11K015T K15K015T	
	1,000 r/min Servomotors	INC	-	K2K010H	K3K010H	-	-	
		INC	-	K2K010T	K3K010T K4K510T	K6K010T	-	

\*1. The heat value is given for rated operation.

● Servo Drives with 400 VAC Input Power  
for Three-phase input type

Item			R88D-KT06F	R88D-KT10F	R88D-KT15F	R88D-KT20F	R88D-KT30F	R88D-KT50F	R88D-KT75F	R88D-KT150F
Continuous output current (rms)			1.5A	2.9A	4.7A	6.7A	9.4A	16.5A	22.0A	33.4A
Input power supply	Main circuit	Power supply capacity	1.2KVA	1.8KVA	2.3KVA	3.8KVA	4.5KVA	6.0KVA	11.0KVA	22.0KVA
		Power supply voltage	3-phase 380 to 480 VAC (323 to 528 V), 50/60 Hz							
		Rated current	2.1A	2.8A	3.9A	5.9A	7.6A	12.1A	16.0A	29.0A
		Heat value*1	32.2W	48W	49W	65W	108W	200W	300W	590W
	Control circuit	Power supply voltage	24 VDC (20.4 to 27.6)							
		Heat value*1	7W	7W	7W	10W	13W	13W	15W	22W
Weight			Approx. 1.9kg	Approx. 1.9kg	Approx. 1.9kg	Approx. 2.7kg	Approx. 4.7kg	Approx. 4.7kg	Approx. 13.5kg	Approx. 21.0kg
Maximum applicable motor capacity			600W	1kW	1.5kW	2kW	3kW	5kW	7.5kW	15kW
Applicable Servomotors (R88M-)	3,000 r/min Servomotors	INC	-	K75030F	K1K030F K1K530F	K2K030F	K3K030F	K4K030F K5K030F	-	-
		ABS	-	K75030C	K1K030C K1K530C	K2K030C	K3K030C	K4K030C K5K030C	-	-
	2,000 r/min, 1,500 r/min Servomotors	INC	K40020F K60020F	K1K020F	K1K520F	K2K020F	K3K020F	K4K020F K5K020F	-	-
		ABS	K40020C K60020C	K1K020C	K1K520C	K2K020C	K3K020C	K4K020C K5K020C	K7K515C	K11K015C K15K015C
	1,000 r/min Servomotors	INC	-	-	K90010F	-	K2K010F	K3K010F	-	-
		ABS	-	-	K90010C	-	K2K010C	K3K010C K4K510C	K6K010C	-

\*1. The heat value is given for rated operation.

## Components and Functions

### Servo Drive Part Names

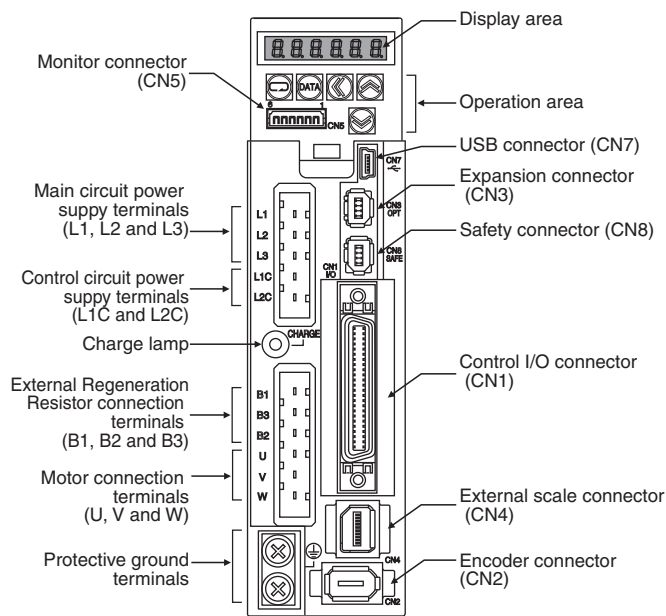

#### Display area

A 6-digit 7-segment LED display shows the Servo Drive status, alarm codes, parameters, and other information.

#### Operation area

Monitors the parameter setting and driver condition.

#### Charge Lamp

Lits when the main circuit power supply is turned ON.

#### Control I/O Connector (CN1)

Used for command input signals and I/O signals.

#### Encoder connector (CN2)

Connector for the encoder installed in the Servomotor.

#### Expansion Connector (CN3)

A spare connector for expansion. Do not connect anything.

#### External Scale Connector (CN4)

Connector for an encoder signal used during full closing control.

#### Monitor Connector (CN5)

Uses a specified cable to monitor the motor rotation speed, torque command value, etc.

#### USB connector (CN7)

Communications connector for the computer.

#### Safety Connector (CN8)

Connector for the safety devices.

If no safety device is used, keep the factory-set safety bypass connector installed.

#### Main Circuit Terminal (CNA)

Main-circuit power terminals (L1, L2, L3)

Control-circuit power terminals (CNA)

#### Motor connection terminals (CNB)

External Regeneration Resistor connection terminals (B1,B2,B3)

Servomotor connection terminals (U, V, W)

## \*External Encoder

Contact the encoder manufacturer to find out the detailed specifications such as operating environment before use.

External encoder type	Maker	Example of External encoder	Supported speed *1	Resolution *4 [μm]	Maximum speed *4 [m/s]
90° phase difference output type *2 *3	–	Phase A/B type	0 to 4 Mpps (Multiplication × 4)	–	–
Serial communications type (Incremental type) *3	Magnescale Co., Ltd	SL700+PL101RP/RHP SL710+PL101RP/RHP	0 to 400 Mpps	0.1	10
		SR75/SR85		0.01 to 1	3.3
		BF1		0.001/0.01	0.4/1.8
		SQ10+PQ11 SQ10+PQ10+MQ10		0.05/0.1/ 0.5/1	3
	NIDEC SANKYO CORPORATION	PSLH041+PSLG		0.1	6

\*1. The supported speed is the internal feedback pulse speed [external encoder pulse/s] of the external encoder that can be processed by the Servo Drive.

Check the instruction manual of the external encoder for the speed range supported by your external encoder.

\*2. These are the directions that the Drive counts a 90° phase difference output.

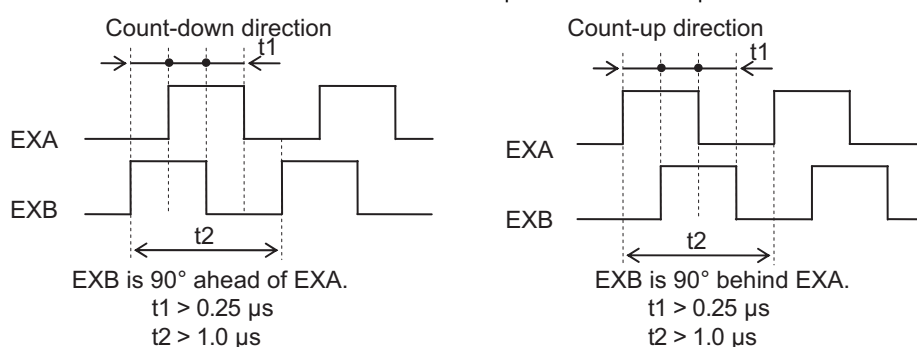

\*3. For the external encoder connection direction, set the direction so that count-up occurs when the motor shaft is rotating counterclockwise, and count-down occurs when the motor shaft is rotating clockwise. If the connection direction cannot be selected due to installation conditions or any other reason, the count direction can be reversed using External Feedback Pulse Direction Switching (Pn326).

\*4. The resolution and maximum speed are the values for the G5-series Servo Drive. The resolution and maximum speed may be different from the specifications of the feedback encoder due to restriction on the maximum pulse frequency of the Servo Drive.

## Functions

### Basic control

Position control	Internally set speed control
Speed control	Switching control
Torque control	Full closing control*

\* Absolute type external encoder can not connected.

### Advanced control

Vibration control	Gain switching	Friction torque compensation function
Adaptive filter	Torque limit	Inertia ratio switching function
Notch filter	Sequence I/O signal	Hybrid Vibration Suppression Function
Electronic gear function	Forward and reverse drive prohibition functions	Feed-forward function
Encoder dividing function	Disturbance observer function	Instantaneous speed observer function
Brake interlock	Gain switching 3 function	

## Other functions

### Safe Torque OFF (STO) Function

Realtime autotuning

Manual tuning

### Various parameters

Basic Parameters	Interface Monitor Setting Parameters
Gain Parameters	Extended Parameters
Vibration Suppression Parameters	Special Parameters
Analog Control Parameters	

## Dimensions

### <Wall Mounting>

Single-phase 100 VAC R88D-KTA5L/-KT01L (50 to 100W)

Single-phase/Three-phase 200 VAC R88D-KT01H/-KT02H (100 to 200W)

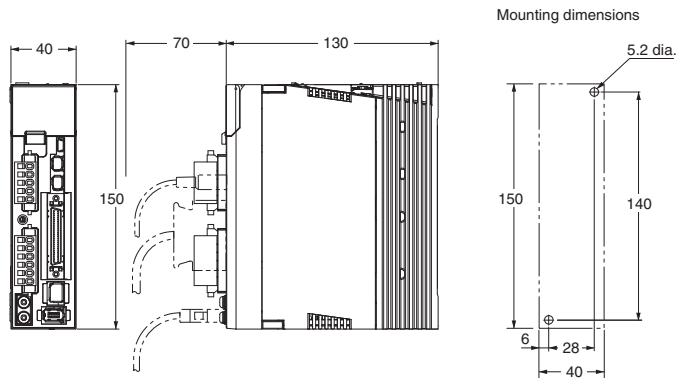

Single-phase/Three-phase 100 VAC R88D-KT02L (200W)

Single-phase/Three-phase 200 VAC R88D-KT04H (400W)

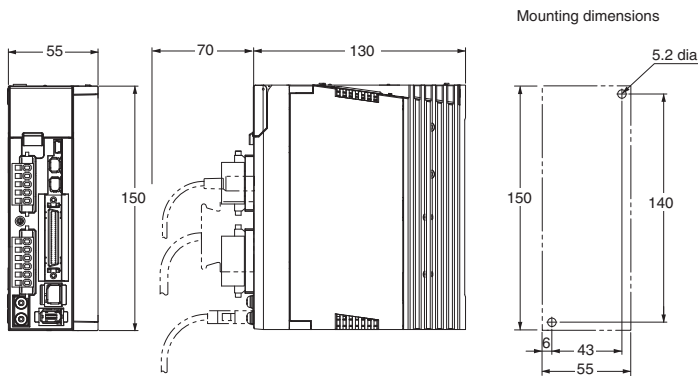

Single-phase 100 VAC R88D-KT04L (400W)

Single-phase/Three-phase 200 VAC R88D-KT08H (750W)

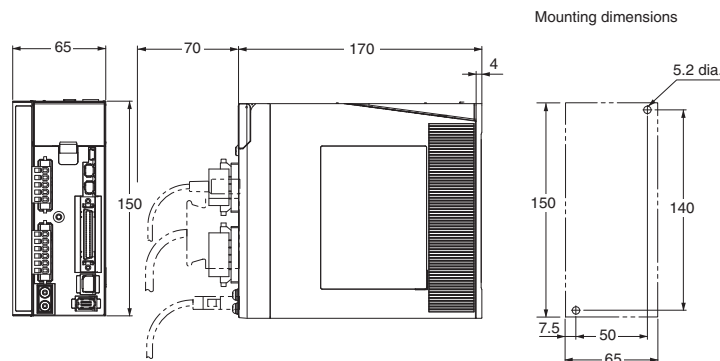

Single-phase/Three-phase 200 VAC R88D-KT10H/-KT15H (900W to 1.5kW)

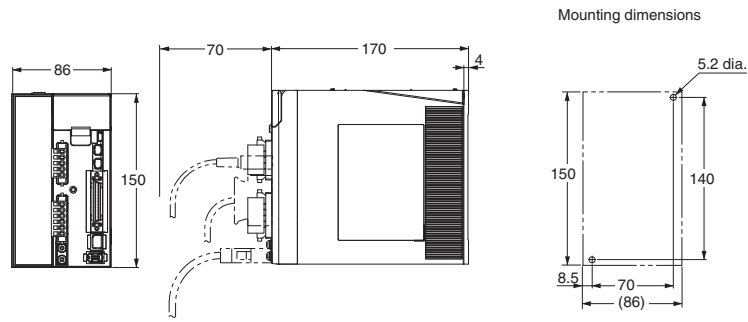

Three-phase 200 VAC R88D-KT20H (2kW)

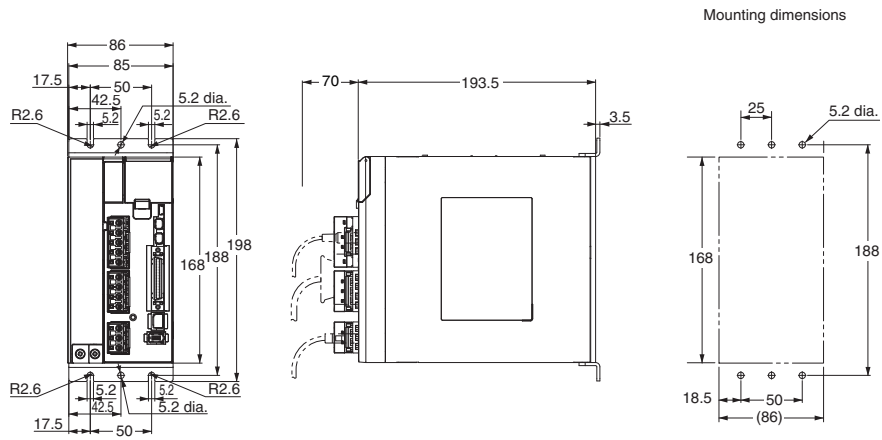

Three-phase 200 VAC R88D-KT30H/-KT50H (3 to 5kW)

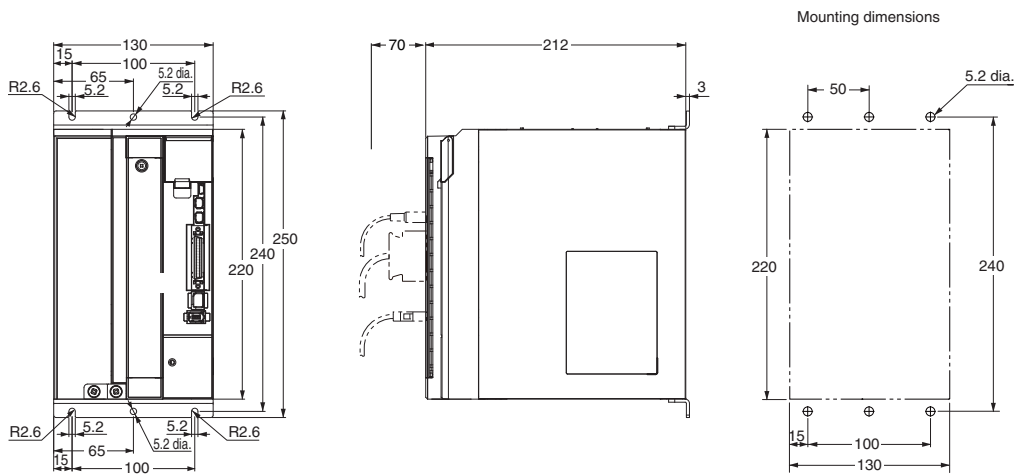

Three-phase 200 VAC R88D-KT75H (7.5kW)

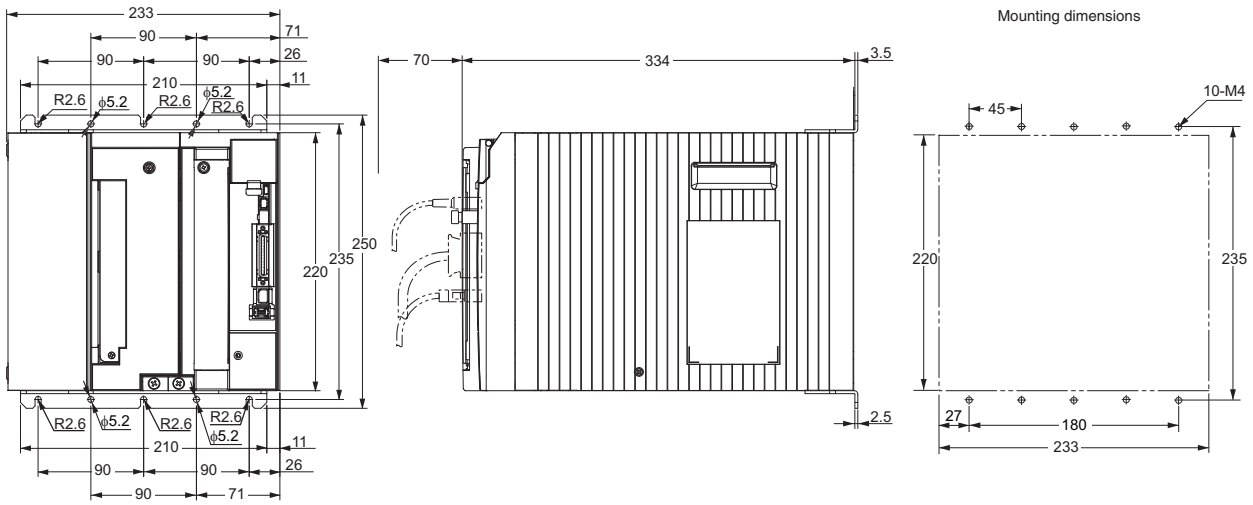

Three-phase 200 VAC R88D-KT150H (15kW)

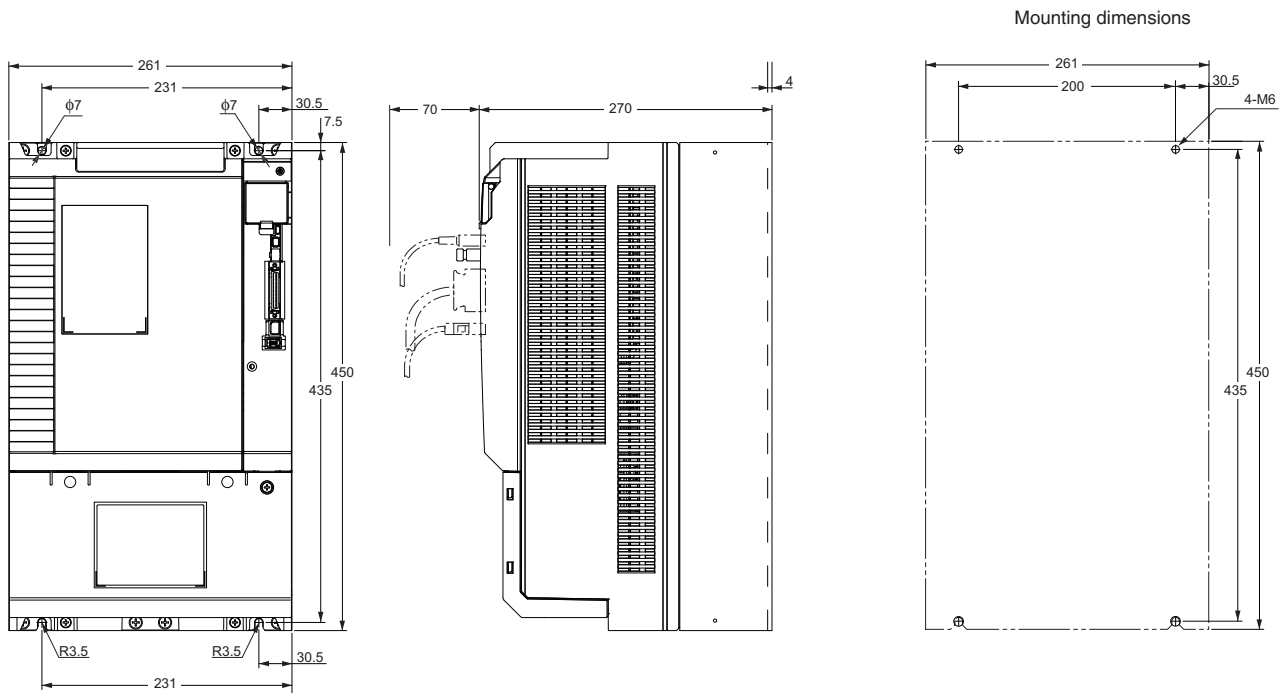

G5-Series  
System Configuration

EtherCAT Communications  
AC Servo Drive

EtherCAT Communications  
Linear Motor Type  
AC Servo Drive

General-purpose Inputs  
AC Servo Drive

ML-II Type  
AC Servo Drive

AC Servomotors

Linear Motor

Decelerator

Three-phase 400 VAC R88D-KT06F/-KT10F/-KT15F (600W to 1.5kW)

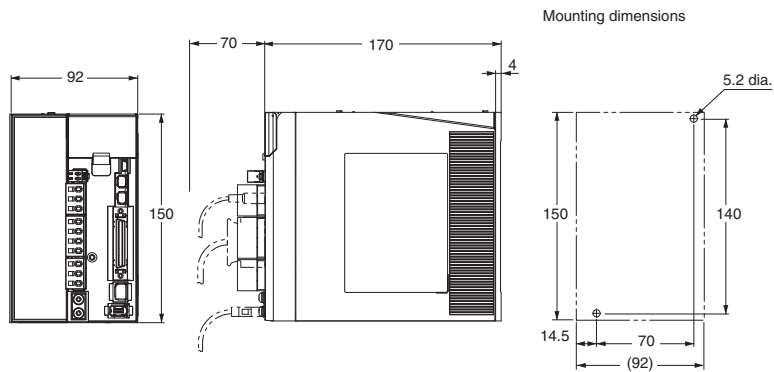

Three-phase 400 VAC R88D-KT20F (2kW)

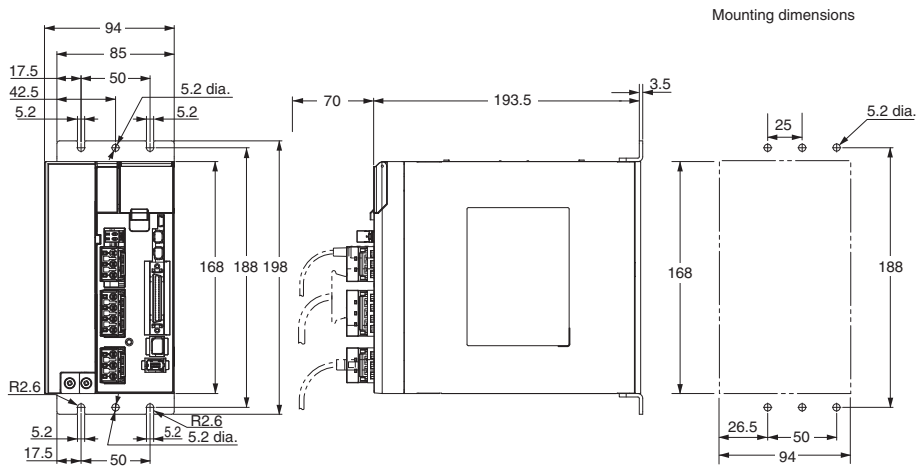

Three-phase 400 VAC R88D-KT30F/-KT50F (3 to 5kW)

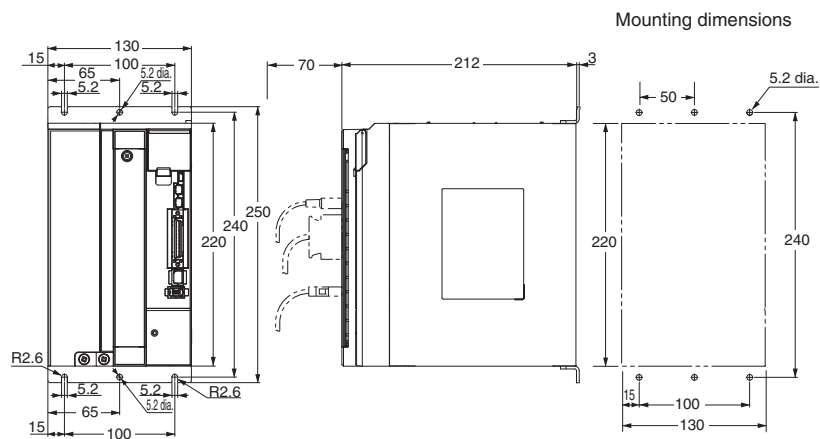



# R88D-KN□-ML2

## Contents



- Ordering Information
- Specifications
  - General Specifications
  - Characteristics
    - Servo Drives with Single-phase 100 VAC Input Power
    - Servo Drives with Single-phase or three-phase 200 VAC Input Power
    - Servo Drives with Three-phase 200 VAC Input Power
    - Servo Drives with 400 VAC Input Power
- Names and Functions
  - Servo Drive Part Names
  - Functions
- Dimensions

## Ordering Information

Refer to the Ordering Information.

## Specifications

### General Specifications

Item		Specifications	
Ambient operating temperature and operating humidity		0 to +55C, 85% max. (with no condensation)	
Storage ambient temperature and humidity		-20 to +65C, 85% max. (with no condensation)	
Operating and storage atmosphere		No corrosive gases	
Vibration resistance		10 to 60 Hz and at an acceleration of 5.88 m/s <sup>2</sup> or less (Not to be run continuously at the resonance point)	
Insulation resistance		Between power supply terminal/power terminal and FG terminal: 0.5 MΩ min. (at 500 VDC Megger)	
Dielectric strength		Between power supply/power line terminals and FG terminal: 1,500 VAC for 1 min at 50/60 Hz	
Protective structure		Built into panel	
International standard	EC directives	EMC directive	EN55011, EN61000-6-2, IEC61800-3
		Low voltage directive	EN61800-5-1
		Machinery directives	EN954-1 (Cat.3), EN ISO 13849-1: 2008 (PLC,d), ISO 13849-1: 2006 (PLC,d), EN61508 (SIL2), EN62061 (SIL2), EN61800-5-2 (STO), IEC61326-3-1 (SIL2)
	UL standards	UL508C	
	CSA standards	CSA C22.2 No.14	
Korean Radio Regulations (KC)		Certified	

**Note: 1.** The above items reflect individual evaluation testing. The results may differ under compound conditions.

**Note: 2.** Always disconnect all connections to the Servo Drive before you perform insulation resistance tests on it. If you perform an insulation resistance test while the Servo Drive is connected, the Servo Drive may be damaged. Never perform dielectric strength tests on the Servo Drive. Failure to follow this precaution may result in damaging internal elements.

**Note: 3.** Some Servo Drive parts will require maintenance. For details, refer to the G5 series USER'S MANUAL. Confirm the Manual No. that is listed in Related Manuals.

## Characteristics

### ● Servo Driver with 100 VAC Input Power for Single-phase input type

Item			R88D-KNA5L-ML2	R88D-KN01L-ML2	R88D-KN02L-ML2	R88D-KN04L-ML2
Continuous output current (rms)			1.2A	1.7A	2.5A	4.6A
Input power supply	Main circuit	Power supply capacity	0.4KVA	0.4KVA	0.5KVA	0.9KVA
		Power supply voltage	Single-phase 100 to 120 VAC (85 to 132 V), 50/60 Hz			
		Rated current	1.7A	2.6A	4.3A	7.6A
		Heat value*1	11W	16.6W	21W	25W
	Control circuit	Power supply voltage	Single-phase 100 to 120 VAC (85 to 132 V), 50/60 Hz			
		Heat value*1	4W	4W	4W	4W
Weight			Approx. 0.8 kg	Approx. 0.8kg	Approx. 1.0kg	Approx. 1.6kg
Maximum applicable motor capacity			50W	100W	200W	400W
Applicable Servomotors (R88M-)	3,000 r/min Servomotors	<b>INC</b>	K05030H	K10030L	K20030L	K40030L
		<b>ABS</b>	K05030T	K10030S	K20030S	K40030S
	2,000 r/min Servomotors	<b>ABS</b>	-	-	-	-
		<b>ABS</b>	-	-	-	-
	1,000 r/min Servomotors	<b>ABS</b>	-	-	-	-
		<b>ABS</b>	-	-	-	-

\*1. The heat value is given for rated operation.

### ● Servo Driver with 200 VAC Input Power for Single-phase/Three-phase input type

Item			R88D-KN01H-ML2	R88D-KN02H-ML2	R88D-KN04H-ML2	R88D-KN08H-ML2	R88D-KN10H-ML2	R88D-KN15H-ML2
Continuous output current (rms)			1.2A	1.6A	2.6A	4.1A	5.9A	9.4A
Input power supply	Main circuit	Power supply capacity	0.5KVA	0.5KVA	0.9KVA	1.3KVA	1.8KVA	2.3KVA
		Power supply voltage	Single-phase or Three-phase 200 to 240 VAC (170 to 264 V), 50/60 Hz					
		Rated current	1.6/0.9A *1	2.4/1.3A *1	4.1/2.4A *1	6.6/3.6A *1	9.1/5.2A *1	14.2/8.1A *1
		Heat value*2	14.3/13.7W *1	23/19 W *1	33/24 W *1	30/35.5 W *1	57/49 W *1	104/93 W *1
	Control circuit	Power supply voltage	Single-phase 200 to 240 VAC (170 to 264 V), 50/60 Hz					
		Heat value*2	4W	4W	4W	4W	7W	7W
Weight			Approx. 0.8kg	Approx. 0.8kg	Approx. 1.1kg	Approx. 1.6kg	Approx. 1.8kg	Approx. 1.8kg
Maximum applicable motor capacity			100W	200W	400W	750W	1kW	1.5kW
Applicable Servomotors (R88M-)	3,000 r/min Servomotors	<b>INC</b>	K05030H K10030H	K20030H	K40030H	K75030H	-	K1K030H K1K530H
		<b>ABS</b>	K05030T K10030T	K20030T	K40030T	K75030T	-	K1K030T K1K530T
	2,000 r/min Servomotors	<b>INC</b>	-	-	-	-	K1K020H	K1K520H
		<b>ABS</b>	-	-	-	-	K1K020T	K1K520T
	1,000 r/min Servomotors	<b>INC</b>	-	-	-	-	-	K90010H
		<b>ABS</b>	-	-	-	-	-	K90010T

\*1. The left value is for single-phase input power and the right value is for three-phase input power.

\*2. The heat value is given for rated operation.

# AC Servomotor/Drive G5-series

## ● Servo Driver with 200 VAC Input Power for Three-phase input type

Item			R88D-KN20H-ML2	R88D-KN30H-ML2	R88D-KN50H-ML2
Continuous output current (rms)			13.4A	18.7A	33.0A
Input power supply	Main circuit	Power supply capacity	3.3KVA	4.5KVA	7.5KVA
		Power supply voltage	Three-phase 200 to 230 VAC (170 to 253 V), 50/60 Hz		
		Rated current	11.8A	15.1A	21.6A
		Heat value*1	139W	108W	328W
	Control circuit	Power supply voltage	Single-phase 200 to 230 VAC (170 to 253 V), 50/60 Hz		
		Heat value*1	10W	13W	13W
Weight			Approx. 2.7kg	Approx. 4.8kg	Approx. 4.8kg
Maximum applicable motor capacity			2kW	3kW	5kW
Applicable Servomotors (R88M-)	3,000 r/min Servomotors	<b>INC</b>	K2K030H	K3K030H	K4K030H K5K030H
		<b>ABS</b>	K2K030T	K3K030T	K4K030T K5K030T
	2,000 r/min Servomotors	<b>INC</b>	K2K020H	K3K020H	K4K020H K5K020H
		<b>ABS</b>	K2K020T	K3K020T	K4K020T K5K020T
	1,000 r/min Servomotors	<b>INC</b>	–	K2K010H	K3K010H
		<b>INC</b>	–	K2K010T	K3K010T

\*1. The heat value is given for rated operation.

## ● Servo Driver with 400 VAC Input Power for Three-phase input type

Item			R88D-KN06F-ML2	R88D-KN10F-ML2	R88D-KN15F-ML2	R88D-KN20F-ML2	R88D-KN30F-ML2	R88D-KN50F-ML2
Continuous output current (rms)			1.5A	2.9A	4.7A	6.7A	9.4A	16.5A
Input power supply	Main circuit	Power supply capacity	1.2KVA	1.8KVA	2.3KVA	3.8KVA	4.5KVA	6.0KVA
		Power supply voltage	Single-phase 380 to 480 VAC (323 to 528 V), 50/60 Hz					
		Rated current	2.1A	2.8A	3.9A	5.9A	7.6A	12.1A
		Heat value*1	32.2W	48W	49W	65W	108W	200W
	Control circuit	Power supply voltage	24 VDC (20.4 to 27.6)					
		Heat value*1	7W	7W	7W	10W	13W	13W
Weight			Approx. 1.9kg	Approx. 1.9kg	Approx. 1.9kg	Approx. 2.7kg	Approx. 4.7kg	Approx. 4.7kg
Maximum applicable motor capacity			600W	1kW	1.5kW	2kW	3kW	5kW
Applicable Servomotors (R88M-)	3,000 r/min Servomotors	<b>INC</b>	–	K75030F	K1K030F K1K530F	K2K030F	K3K030F	K4K030F K5K030F
		<b>ABS</b>	–	K75030C	K1K030C K1K530C	K2K030C	K3K030C	K4K030C K5K030C
	2,000 r/min Servomotors	<b>INC</b>	K40020F K60020F	K1K020F	K1K520F	K2K020F	K3K020F	K4K020F K5K020F
		<b>ABS</b>	K40020C K60020C	K1K020C	K1K520C	K2K020C	K3K020C	K4K020C K5K020C
	1,000 r/min Servomotors	<b>INC</b>	–	–	K90010F	–	K2K010F	K3K010F
		<b>ABS</b>	–	–	K90010C	–	K2K010C	K3K010C

\*1. The heat value is given for rated operation.

# Components and Functions

## Servo Drive Part Names

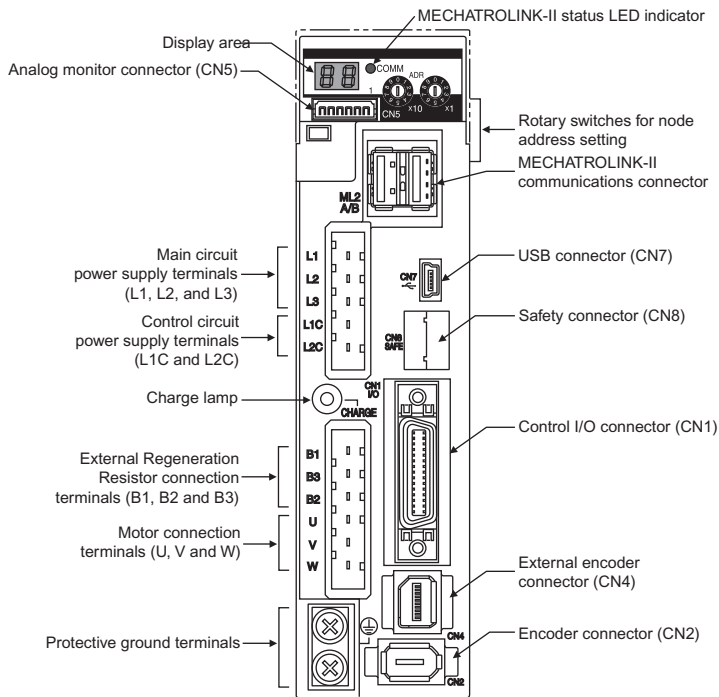

### Display area

A 2-digit 7-segment LED indicator shows the node address, alarm codes, and other driver status.

### Charge Lamp

Lits when the main circuit power supply is turned ON.

### MECHATROLINK-II Status LED Indicator

Indicates the communications status of the MECHATROLINK-II.

### Control I/O Connector (CN1)

Used for command input signals and I/O signals.

### Encoder connector (CN2)

Connector for the encoder installed in the Servomotor.

### External Encoder Connector (CN4)

Connector for an encoder signal used during full closing control.

### Analog Monitor Connector (CN5)

2 analog outputs to monitor values like motor rotation speed, torque command value, etc.

### MECHATROLINK-II Communications Connectors (ML2A and ML2B)

Connectors for MECHATROLINK-II communications.

### USB Connector (CN7)

Communications Connector for the computer.

### Safety Connector (CN8)

Connector for the safety devices.

If no safety device is used, keep the factory-set safety bypass connector installed.

# AC Servomotor/Drive G5-series

## \*External Encoder

Contact the encoder manufacturer to find out the detailed specifications such as operating environment before use.

External encoder type	Maker	Example of External encoder	Supported speed *1	Resolution *4 [μm]	Maximum speed *4 [m/s]
90° phase difference output type *2 *3	–	Phase A/B type	0 to 4 Mpps (Multiplication × 4)	–	–
Serial communications type (Incremental type) *3	Magnescale Co., Ltd	SL700+PL101RP/RHP SL710+PL101RP/RHP	0 to 400 Mpps	0.1	10
		SR75/SR85		0.01 to 1	3.3
		BF1		0.001/0.01	0.4/1.8
		SQ10+PQ11 SQ10+PQ10+MQ10		0.05/0.1/0.5/ 1	3
	NIDEC SANKYO CORPORATION	PSLH041+PSLG		0.1	6
Serial communications type (Absolute type) *3	HEIDENHAIN CORPORATION	LIC2197P/LIC2199P	0 to 400 Mpps	0.05/0.1	10
		LIC4193P/LIC4195P LIC4197P/LIC4199P		0.001/0.005/ 0.01	0.4/2/4
		LC195P/LC495P		0.001/0.01	3
	FAGOR AUTOMATION	SAP/SVAP/GAP		0.05	2.5
		S2AP/SV2AP/G2AP		0.01/0.05	3
	Magnescale Co., Ltd	LAP		0.05/0.1	2
		SR77/SR87		0.01 to 1	3.3
	Mitutoyo Corporation	AT573□		0.05	2.5
		ST77□□ ST137□□		0.1	5
	Renishaw Co.	RESOLUTE		0.001/0.01	8
				0.001	0.4
				0.05	20
		0.1	40		

\*1. The supported speed is the internal feedback pulse speed [external encoder pulse/s] of the external encoder that can be processed by the Servo Drive.

Check the instruction manual of the external encoder for the speed range supported by your external encoder.

\*2. These are the directions that the Drive counts a 90° phase difference output.

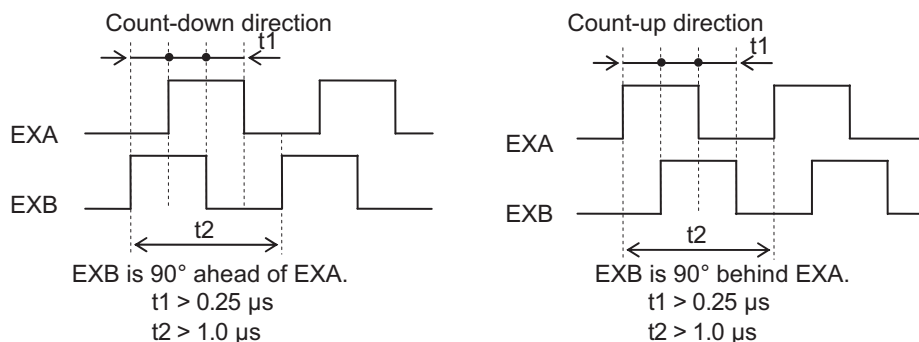

\*3. For the external encoder connection direction, set the direction so that count-up occurs when the motor shaft is rotating counterclockwise, and count-down occurs when the motor shaft is rotating clockwise. If the connection direction cannot be selected due to installation conditions or any other reason, the count direction can be reversed using External Feedback Pulse Direction Switching (Pn326).

\*4. The resolution and maximum speed are the values for the G5-series Servo Drive. The resolution and maximum speed may be different from the specifications of the feedback encoder due to restriction on the maximum pulse frequency of the Servo Drive.

## Functions

### Basic control

Position control	Internally set speed control
Speed control	Switching control
Torque control	Full closing control

### Advanced control

Vibration control	Gain switching	Friction torque compensation function
Adaptive filter	Torque limit	Inertia ratio switching function
Notch filter	Sequence I/O signal	Hybrid Vibration Suppression Function
Electronic gear function	Forward and reverse drive prohibition functions	Feed-forward function
Encoder dividing function	Disturbance observer function	Instantaneous speed observer function
Brake interlock	Gain switching 3 function	

### Other functions

#### Safe Torque OFF (STO) Function

Realtime autotuning

Manual tuning

#### Various parameters

Basic Parameters	Interface Monitor Setting Parameters
Gain Parameters	Extended Parameters
Vibration Suppression Parameters	Special Parameters
Analog Control Parameters	

Dimensions

<Wall Mounting>

Single-phase 100VAC R88D-KNA5L-ML2/-KN01L-ML2 (50 to 100W)

Single-phase/Three-phase 200VAC R88D-KN01H-ML2/-KN02H-ML2 (100 to 200W)

External dimensions

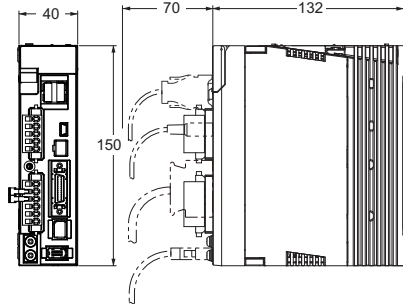

Mounting dimensions

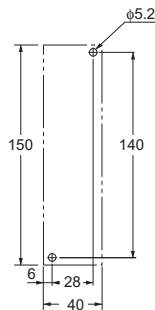

Single-phase/Three-phase 100VAC R88D-KN02L-ML2 (200W)

Single-phase/Three-phase 200VAC R88D-KN04H-ML2 (400W)

External dimensions

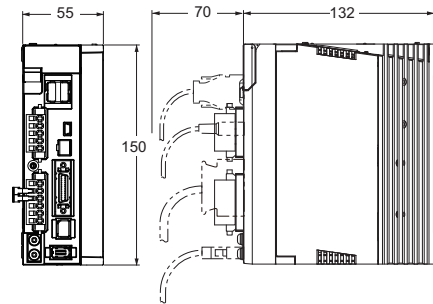

Mounting dimensions

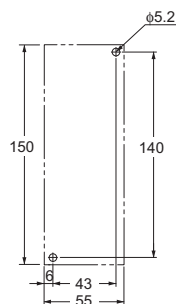

Single-phase/Three-phase 100VAC R88D-KN04L-ML2 (400W)

Single-phase/Three-phase 200VAC R88D-KN08H-ML2 (750W)

External dimensions

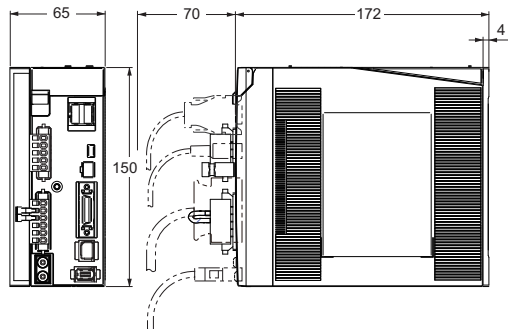

Mounting dimensions

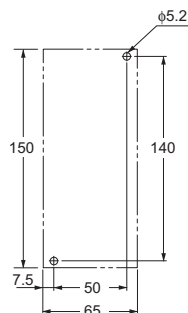



**Three-phase 400VAC R88D-KN06F-ML2/-KN10F-ML2 (600 to 1.0kW)  
Three-phase 400VAC R88D-KN15F-ML2 (1.5kW)**

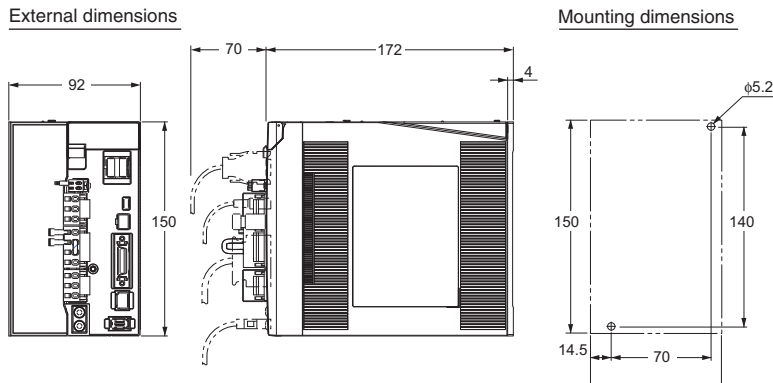

**Three-phase 400VAC R88D-KN20F-ML2 (2kW)**

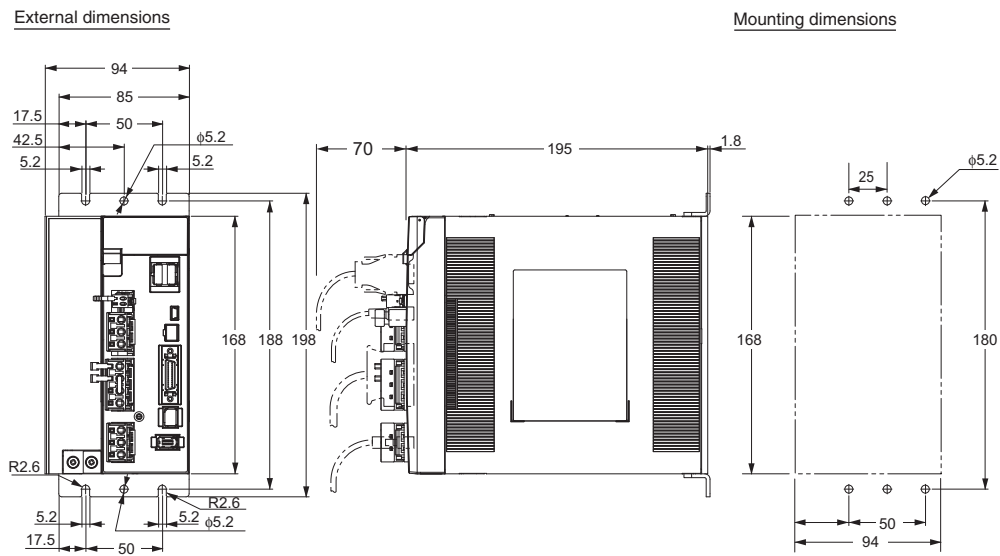

**Three-phase 400VAC R88D-KN30F-ML2/-KN50F-ML2 (3 to 5kW)**

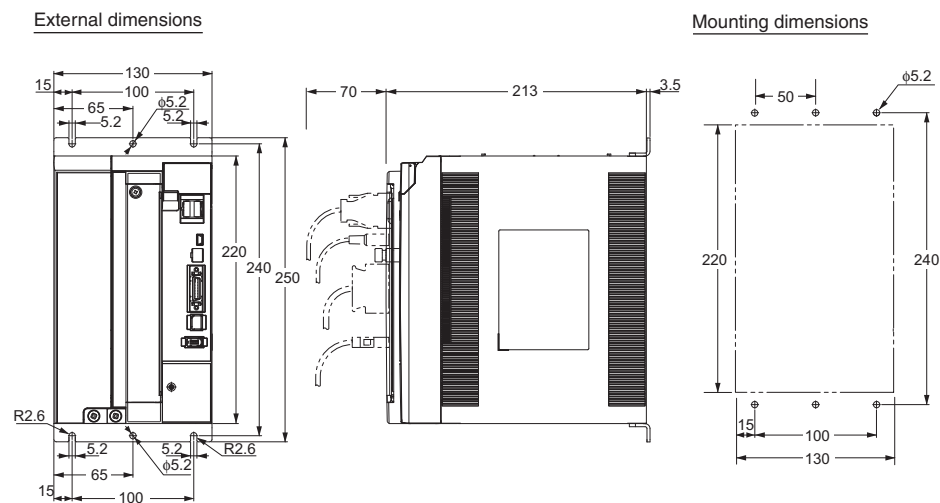

# G5-series AC Servomotors

# R88M-K INC ABS/INC

## Contents

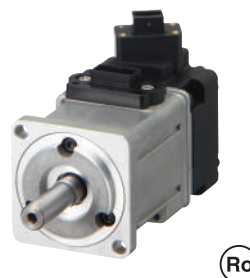

- Ordering Information
- Specifications
  - General Specifications
  - Characteristics/Torque and Rotation Speed Characteristics
  - <Cylinder type>
    - 3,000 r/min servomotors (100V, 200V, 400V)
    - 2,000 r/min servomotors (200V, 400V)
    - 1,500 r/min servomotors (200V/400V)
    - 1,000 r/min servomotors (200V/400V)
  - Encoder Specifications
- Dimensions

## Ordering Information

Refer to the Ordering Information.

## Specifications

### General Specifications

Item	3,000-r/min motors		1,000-r/min motors 1,500-r/min motors 2,000-r/min motors
	50 to 750W	1 to 5kW	900 W to 15kW
<b>Ambient operating temperature and operating humidity</b>	0 to 40°C 20 to 85% RH (with no condensation)		
<b>Storage ambient temperature and humidity</b>	-20 to +65°C, 20% to 85% RH (with no condensation) Guaranteed maximum temperature: 72 hours at 80°C		
<b>Operating and storage atmosphere</b>	No corrosive gases		
<b>Vibration resistance *1</b>	Acceleration of 49 m/s <sup>2</sup> *2 24.5 m/s <sup>2</sup> max. in X, Y, and Z directions when the motor is stopped		
<b>Impact resistance</b>	Acceleration of 98 m/s <sup>2</sup> max. 3 times each in X, Y, and Z directions		
<b>Insulation resistance</b>	Between power terminal and FG terminal: 20 MΩ min. (at 500 VDC Megger)		
<b>Dielectric strength</b>	1,500 VAC between power terminal and FG terminal (sensed current 10 mA) for 1 min (voltage 100 V, 200 V) 1,800 VAC between power terminal and FG terminal (sensed current 10 mA) for 1 min (voltage 400 V) 1,000 VAC between brake terminal and FG terminal (sensed current 10 mA) for 1 min		
<b>Insulation class</b>	Class B	Class F	
<b>Protective structure</b>	IP67 (except for through-shaft parts and motor and encoder connector pins)		
<b>International standard</b>	<b>EC directive</b>	<b>Low voltage directive</b>	EN60034-1/-5
	<b>UL standards</b>		UL1004-1
	<b>CSA standards</b>		CSA C22.2 No.100
			UL1004-1, UL1004-6 *3

\*1. The amplitude may be amplified by machine resonance. Do not exceed 80% of the specified value for extended periods of time.

\*2. 24.5m/s<sup>2</sup> is specified for 1,500-r/min Servomotors of 7.5 to 15 kW and 1,000-r/min Servomotors of 4.5 to 6 kW.

\*3. UL 1004-6 applies only to 1,500-r/min Servomotors of 7.5 to 15 kW and 1,000-r/min Servomotors of 4.5 to 6 kW.

**Note: 1.** Do not use the cable when it is laying in oil or water.

**Note: 2.** Do not expose the cable outlet or connections to stress due to bending or the weight of the cable itself.

**Note: 3.** Always disconnect all connections to the Servo Motor before you perform insulation resistance tests on it. If you perform an insulation resistance test while the Servo Motor is connected, the Servo Motor may be damaged. Never perform dielectric strength tests on the Servo Motor. Failure to follow this precaution may result in damaging internal elements.

**Note: 4.** To conform EMC directive, the tips on wiring and installation written in the G5 series user's manual must be followed. Confirm the Manual No. that is listed in Related Manuals.

## Characteristics/Torque and Rotation Speed Characteristics

### Characteristics

<Cylinder type>

3,000 r/min Servomotors (100 VAC Input Power)

Model (R88M-)		K05030H	K10030L	K20030L	K40030L	
Item	Unit	K05030T	K10030S	K20030S	K40030S	
Rated output *1	W	50	100	200	400	
Rated torque *1	N • m	0.16	0.32	0.64	1.3	
Rated rotation speed	r/min	3,000				
Momentary maximum rotation speed	r/min	6,000				
Momentary maximum torque*1	N • m	0.48	0.95	1.91	3.8	
Rated current *1	A (rms)	1.1	1.6	2.5	4.6	
Momentary maximum current*1	A (0-p)	4.7	6.9	10.6	19.5	
Rotor inertia	Without brake	kg • m <sup>2</sup>	0.025×10 <sup>-4</sup>	0.051×10 <sup>-4</sup>	0.14×10 <sup>-4</sup>	0.26×10 <sup>-4</sup>
	With brake	kg • m <sup>2</sup>	0.027×10 <sup>-4</sup>	0.054×10 <sup>-4</sup>	0.16×10 <sup>-4</sup>	0.28×10 <sup>-4</sup>
Applicable load inertia	–	30 times the rotor inertia max. *2				
Torque constant *1	N • m/A	0.11±10%	0.14±10%	0.20±10%	0.21±10%	
Power rate *1	Without brake	kW/s	10.1	19.8	28.9	62.4
	With brake	kW/s	9.4	18.7	25.3	37.8
Mechanical time constant	Without brake	ms	1.43	1.03	0.61	0.48
	With brake	ms	1.54	1.09	0.70	0.52
Electrical time constant	ms	0.82	0.91	3.0	3.4	
Allowable radial load *3	N	68	68	245	245	
Allowable thrust load *3	N	58	58	98	98	
Weight	Without brake	kg	Approx. 0.31	Approx. 0.45	Approx. 0.78	Approx. 1.2
	With brake	kg	Approx. 0.51	Approx. 0.65	Approx. 1.2	Approx. 1.6
Radiator plate dimensions (material)		100×80×t10 (Al)		130×120×t12 (Al)		
Applicable drivers (R88D-)		KTA5L/KNA5L-ML2/ KNA5L-ECT	KT01L/KN01L-ML2/ KN01L-ECT	KT02L/KN02L-ML2/ KN02L-ECT	KT04L/KN04L-ML2/ KN04L-ECT	
Brake specifications	Brake inertia	kg • m <sup>2</sup>	2×10 <sup>-7</sup>	2×10 <sup>-7</sup>	1.8×10 <sup>-6</sup>	1.8×10 <sup>-6</sup>
	Excitation voltage *4	V	24 VDC±5%			
	Power consumption (at 20°C)	W	7	7	9	9
	Current consumption (at 20°C)	A	0.3	0.3	0.36	0.36
	Static friction torque	N • m	0.29 min.	0.29 min.	1.27 min.	1.27 min.
	Attraction time	ms	35 max.	35 max.	50 max.	50 max.
	Release time	ms	20 max. *5	20 max. *5	15 max. *5	15 max. *5
	Backlash		±1°			
	Allowable work per braking	J	39.2	39.2	137	137
	Allowable total work	J	4.9×10 <sup>3</sup>	4.9×10 <sup>3</sup>	44.1×10 <sup>3</sup>	44.1×10 <sup>3</sup>
	Allowable angular acceleration	rad/s <sup>2</sup>	30,000 max. (Speed of 2,800 r/min or more must not be changed in less than 10 ms)			
	Brake limit	–	10 million times min.			
	Rating	–	Continuous			
Insulation class	–	Type F				

\*1. These are the values when the motor is combined with a driver at normal temperature (20°C, 65%). The momentary maximum torque indicates the standard value.

\*2. Applicable load inertia.

- The operable load inertia ratio (load inertia/rotor inertia) depends on the mechanical configuration and its rigidity. For a machine with high rigidity, operation is possible even with high load inertia. Select an appropriate motor and confirm that operation is possible.
- If the dynamic brake is activated frequently with high load inertia, the Dynamic Brake Resistor may burn. Do not repeatedly turn the servo ON/OFF while the dynamic brake is enabled.
- The dynamic brake is designed only for emergency stops. Design the system so that the Servomotor remains stopped for at least 10 minutes after applying the dynamic brake. Otherwise the dynamic brake circuits may fail.

\*3. The allowable radial and thrust loads are the values determined for a limit of 20,000 hours at normal operating temperatures. The allowable radial loads are applied as shown in the following diagram.

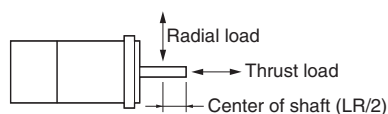

\*4. This is a non-excitation brake. (It is released when excitation voltage is applied.)

\*5. Direct current switching with a varistor (TNR15G271K by Nippon Chemi-Con Corporation or Z15D271 by Ishizuka Electronics Co.).

## Torque and Rotation Speed Characteristics 3,000 r/min Servomotors (100 VAC Input Power)

The following graphs show the characteristics with a 3-m standard cable and a 100 VAC input.

- R88M-K05030H/T (50W)

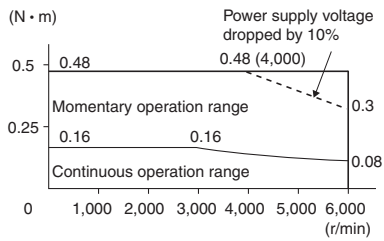

- R88M-K10030L/S (100W)

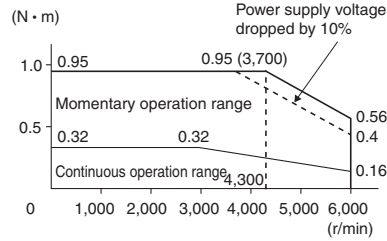

- R88M-K20030L/S (200W)

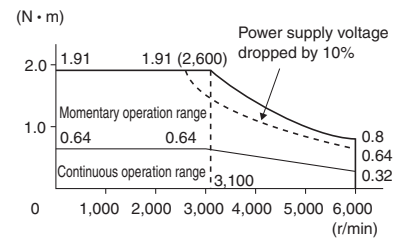

- R88M-K40030L/S (400W)

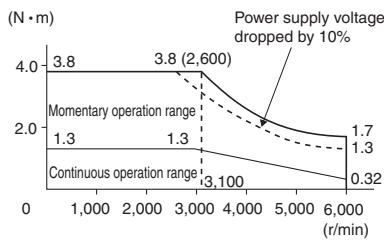

**Note 1:** The continuous operation range is the range in which continuous operation is possible. Continuous operation at the maximum speed is also possible. However, doing so will reduce the output torque.

**Note 2:** If the motor power cable exceeds 20 m, the voltage drop will increase and the momentary operation range will become narrower.

# AC Servomotor/Drive G5-series

## Characteristics

### 3,000 r/min Servomotors (200 VAC Input Power)

Model (R88M-)		K05030H	K10030H	K20030H	K40030H	K75030H	K1K030H	K1K530H	K2K030H	K3K030H	K4K030H	K5K030H		
Unit		K05030T	K10030T	K20030T	K40030T	K75030T	K1K030T	K1K530T	K2K030T	K3K030T	K4K030T	K5K030T		
Rated output *1	W	50	100	200	400	750	1000	1500	2000	3000	4000	5000		
Rated torque *1	N • m	0.16	0.32	0.64	1.3	2.4	3.18	4.77	6.37	9.55	12.7	15.9		
Rated rotation speed	r/min	3,000												
Momentary maximum rotation speed]	r/min	6,000				5,000				4,500				
Momentary maximum torque *1	N • m	0.48	0.95	1.91	3.8	7.1	9.55	14.3	19.1	28.6	38.2	47.7		
Rated current *1	A (rms)	1.1	1.1	1.5	2.4	4.1	6.6	8.2	11.3	18.1	19.6	24.0		
Momentary maximum current *1	A (0-p)	4.7	4.7	6.5	10.2		28	35	48	77	83	102		
Rotor inertia	Without brake	kg • m <sup>2</sup>	0.025×10 <sup>-4</sup>	0.051×10 <sup>-4</sup>	0.14×10 <sup>-4</sup>	0.26×10 <sup>-4</sup>	0.87×10 <sup>-4</sup>	2.03×10 <sup>-4</sup>	2.84×10 <sup>-4</sup>	3.68×10 <sup>-4</sup>	6.50×10 <sup>-4</sup>	12.9×10 <sup>-4</sup>	17.4×10 <sup>-4</sup>	
	With brake	kg • m <sup>2</sup>	0.027×10 <sup>-4</sup>	0.054×10 <sup>-4</sup>	0.16×10 <sup>-4</sup>	0.28×10 <sup>-4</sup>	0.97×10 <sup>-4</sup>	2.35×10 <sup>-4</sup>	3.17×10 <sup>-4</sup>	4.01×10 <sup>-4</sup>	6.85×10 <sup>-4</sup>	14.2×10 <sup>-4</sup>	18.6×10 <sup>-4</sup>	
Applicable load inertia	–	30 times the rotor inertia max. *2					20 times the rotor inertia max. *2	15 times the rotor inertia max. *2		15 times the rotor inertia max. *2				
Torque constant *1	N • m/A	0.11±10%	0.21±10%	0.32±10%	0.40±10%	0.45±10%	0.37	0.45	0.44	0.41	0.49	0.49		
Power rate *1	Without brake	kW/s	10.1	19.8	28.9	62.3	65.4	49.8	80.1	110	140	126	146	
	With brake	kW/s	9.4	18.7	25.3	57.8	58.7	43.0	71.8	101	116	114	136	
Mechanical time constant	Without brake	ms	1.43	1.07	0.58	0.43	0.37	0.61	0.49	0.44	0.41	0.51	0.50	
	With brake	ms	1.54	1.13	0.66	0.46	0.42	0.71	0.55	0.48	0.49	0.56	0.54	
Electrical time constant	ms	0.82	0.90	3.2	3.4	5.3	5.8	6.3	6.7	11	12	13		
Allowable radial load *3	N	68	68	245	245	392	490	490	490	490	784	784		
Allowable thrust load *3	N	58	58	98	98	147	196	196	196	196	343	343		
Weight	Without brake	kg	Approx. 0.31	Approx. 0.46	Approx. 0.79	Approx. 1.2	Approx. 2.3	Approx. 3.5	Approx. 4.4	Approx. 5.3	Approx. 8.3	Approx. 11.0	Approx. 14.0	
	With brake	kg	Approx. 0.51	Approx. 0.66	Approx. 1.2	Approx. 1.6	Approx. 3.1	Approx. 4.5	Approx. 5.4	Approx. 6.3	Approx. 9.4	Approx. 12.6	Approx. 16.0	
Radiator plate dimensions (material)		100×80×t10 (Al)		130×120×t12 (Al)		170×160×t12 (Al)	320×300×t20 (Al)		380×350×t30 (Al)					
Applicable drives (R88D-)		KT01H/ KN01H- ML2/ KN01H- ECT	KT01H/ KN01H- ML2/ KN01H- ECT	KT02H/ KN02H- ML2/ KN02H- ECT	KT04H/ KN04H- ML2/ KN04H- ECT	KT08H/ KN08H- ML2/ KN08H- ECT	KT15H/ KN15H- ML2/ KN15H- ECT	KT15H/ KN15H- ML2/ KN15H- ECT	KT20H/ KN20H- ML2/ KN20H- ECT	KT30H/ KN30H- ML2/ KN30H- ECT	KT50H/ KN50H- ML2/ KN50H- ECT	KT50H/ KN50H- ML2/ KN50H- ECT		
Brake specifications	Brake inertia	kg • m <sup>2</sup>	2×10 <sup>-7</sup>	2×10 <sup>-7</sup>	1.8×10 <sup>-6</sup>	1.8×10 <sup>-6</sup>	0.75×10 <sup>-5</sup>	0.33×10 <sup>-4</sup>	0.33×10 <sup>-4</sup>	0.33×10 <sup>-4</sup>	0.33×10 <sup>-4</sup>	1.35×10 <sup>-4</sup>	1.35×10 <sup>-4</sup>	
	Excitation voltage *4	V	24 VDC±5%					24 VDC±10%						
	Power consumption (at 20°C)	W	7	7	9	9	10	19	19	19	19	22	22	
	Current consumption (at 20°C)	A	0.3	0.3	0.36	0.36	0.42	0.81±10%	0.81±10±	0.81±10%	0.81±10%	0.90±10%	0.90±10%	
	Static friction torque	N • m	0.29 min.	0.29 min.	1.27 min.	1.27 min.	2.45 min.	7.8 min.	7.8 min.	7.8 min.	11.8 min.	16.1 min.	16.1 min.	
	Attraction time	ms	35 max.	35 max.	50 max.	50 max.	70 max.	50 max.	50 max.	50 max.	80 max.	110 max.	110 max.	
	Release time	ms	20 max. *5	20 max. *5	15 max. *5	15 max. *5	20 max. *5	15 max. *6	15 max. *6	15 max. *6	15 max. *6	50 max. *7	50 max. *7	
	Backlash		±1°											
	Allowable work per braking	J	39.2	39.2	137	137	196	392	392	392	392	1470	1470	
	Allowable total work	J	4.9×10 <sup>3</sup>	4.9×10 <sup>3</sup>	44.1×10 <sup>3</sup>	44.1×10 <sup>3</sup>	1.47×10 <sup>5</sup>	4.9×10 <sup>5</sup>	4.9×10 <sup>5</sup>	4.9×10 <sup>5</sup>	4.9×10 <sup>5</sup>	2.2×10 <sup>6</sup>	2.2×10 <sup>6</sup>	
	Allowable angular acceleration	rad/s <sup>2</sup>	30,000 max. (Speed of 2,800 r/min or more must not be changed in less than 10 ms)						10,000					
	Brake limit	–	10 million times min.											
	Rating	–	Continuous											
Insulation class	–	Type F												

\*1. These are the values when the motor is combined with a driver at normal temperature (20°C, 65%). The momentary maximum torque indicates the standard value.

\*2. Applicable load inertia.

- The operable load inertia ratio (load inertia/rotor inertia) depends on the mechanical configuration and its rigidity. For a machine with high rigidity, operation is possible even with high load inertia. Select an appropriate motor and confirm that operation is possible.
- If the dynamic brake is activated frequently with high load inertia, the Dynamic Brake Resistor may burn. Do not repeatedly turn the servo ON/OFF while the dynamic brake is enabled.
- The dynamic brake is designed only for emergency stops. Design the system so that the Servomotor remains stopped for at least 10 minutes after applying the dynamic brake. Otherwise the dynamic brake circuits may fail.

\*3. The allowable radial and thrust loads are the values determined for a limit of 20,000 hours at normal operating temperatures. The allowable radial loads are applied as shown in the following diagram.

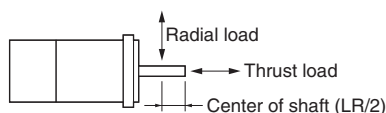

\*4. This is a non-excitation brake. (It is released when excitation voltage is applied.)

\*5. Direct current switching with a varistor (TNR15G271K by Nippon Chemi-Con Corporation or Z15D271 by Ishizuka Electronics Co.).

\*6. Direct current switching with a varistor (Z15D151 by Ishizuka Electronics Co.).

\*7. Direct current switching with a varistor (TNR9G820K by Nippon Chemi-Con Corporation).

## Torque and Rotation Speed Characteristics 3,000 r/min Servomotors (200 VAC Input Power)

The following graphs show the characteristics with a 3 m standard cable and a 200 VAC input.

- R88M-K05030H/T (50W)

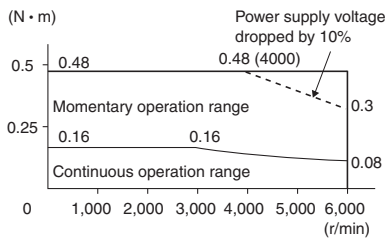

- R88M-K10030H/T (100W)

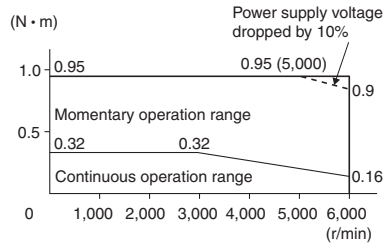

- R88M-K20030H/T (200W)

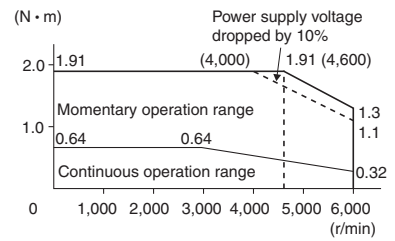

- R88M-K40030H/T (400W)

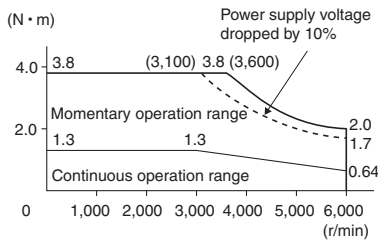

- R88M-K75030H/T (750W)

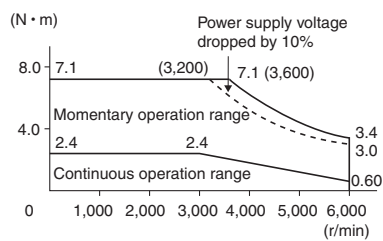

- R88M-K1K030H/T (1kW)

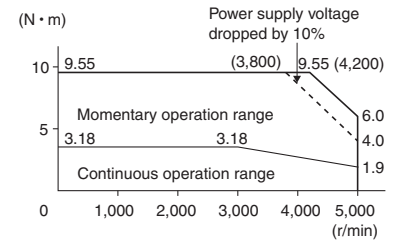

- R88M-K1K530H/T (1.5kW)

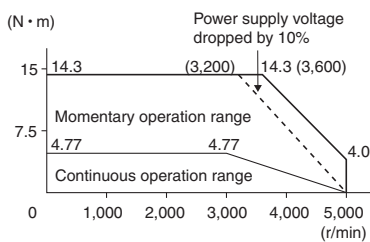

- R88M-K2K030H/T (2kW)

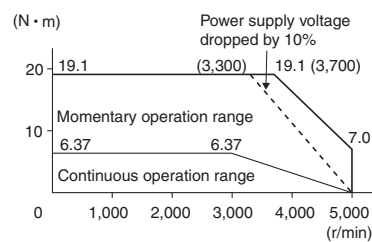

- R88M-K3K030H/T (3kW)

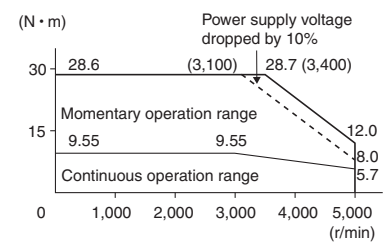

- R88M-K4K030H/T (4kW)

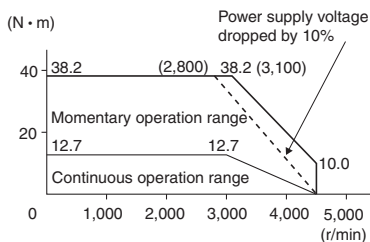

- R88M-K5K030H/T (5kW)

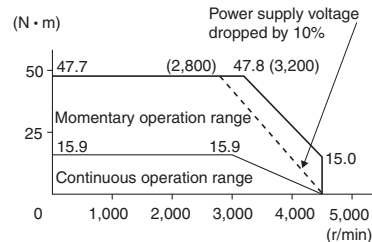

**Note 1:** The continuous operation range is the range in which continuous operation is possible. Continuous operation at the maximum speed is also possible. However, doing so will reduce the output torque.

**Note 2:** If the motor power cable exceeds 20 m, the voltage drop will increase and the momentary operation range will become narrower.

# AC Servomotor/Drive G5-series

## Characteristics

### 3,000 r/min Servomotors (400 VAC Input Power)

Item		Model (R88M-) Unit	K75030F	K1K030F	K1K530F	K2K030F	K3K030F	K4K030F	K5K030F	
			K75030C	K1K030C	K1K530C	K2K030C	K3K030C	K4K030C	K5K030C	
Rated output *1		W	750	1,000	1,500	2,000	3,000	4,000	5,000	
Rated torque *1		N • m	2.39	3.18	4.77	6.37	9.55	12.7	15.9	
Rated rotation speed		r/min	3,000							
Momentary maximum rotation speed		r/min	5,000					4,500		
Momentary maximum torque*1		N • m	7.16	9.55	14.3	19.1	28.6	38.2	47.7	
Rated current *1		A (rms)	2.4	3.3	4.2	5.7	9.2	9.9	12.0	
Momentary maximum current *1		A (0-p)	10	14	18	24	39	42	51	
Rotor inertia	Without brake	kg • m <sup>2</sup>	1.61×10 <sup>-4</sup>	2.03×10 <sup>-4</sup>	2.84×10 <sup>-4</sup>	3.68×10 <sup>-4</sup>	6.50×10 <sup>-4</sup>	12.9×10 <sup>-4</sup>	17.4×10 <sup>-4</sup>	
	With brake	kg • m <sup>2</sup>	1.93×10 <sup>-4</sup>	2.35×10 <sup>-4</sup>	3.17×10 <sup>-4</sup>	4.01×10 <sup>-4</sup>	7.85×10 <sup>-4</sup>	14.2×10 <sup>-4</sup>	18.6×10 <sup>-4</sup>	
Applicable load inertia		–	20 times the rotor inertia max. *2		15 times the rotor inertia max. *2					
Torque constant *1		N • m/A	0.78	0.75	0.89	0.87	0.81	0.98	0.98	
Power rate *1	Without brake	kW/s	35.5	49.8	80.1	110	140	126	146	
	With brake	kW/s	29.6	43	71.8	101	116	114	136	
Mechanical time constant	Without brake	ms	0.67	0.60	0.49	0.45	0.40	0.51	0.50	
	With brake	ms	0.8	0.70	0.55	0.49	0.49	0.56	0.54	
Electrical time constant		ms	5.9	5.8	6.5	6.6	12	13	13	
Allowable radial load *3		N	490	490	490	490	490	784	784	
Allowable thrust load *3		N	196	196	196	196	196	343	343	
Weight	Without brake	kg	Approx. 3.1	Approx. 3.5	Approx. 4.4	Approx. 5.3	Approx. 8.3	Approx. 11.0	Approx. 14.0	
	With brake	kg	Approx. 4.1	Approx. 4.5	Approx. 5.4	Approx. 6.3	Approx. 9.4	Approx. 12.6	Approx. 16.0	
Radiator plate dimensions (material)			320×300×t20 (Al)				380×350×t30 (Al)			
Applicable drives (R88D-)			KT10F/ KN10F-ML2/ KN10F-ECT	KT15F/ KN15F-ML2/ KN15F-ECT	KT15F/ KN15F-ML2/ KN15F-ECT	KT20F/ KN20F-ML2/ KN20F-ECT	KT30F/ KN30F-ML2/ KN30F-ECT	KT50F/ KN50F-ML2/ KN50F-ECT	KT50F/ KN50F-ML2/ KN50F-ECT	
Brake specifications	Brake inertia	kg • m <sup>2</sup>	0.33×10 <sup>-4</sup>	0.33×10 <sup>-4</sup>	0.33×10 <sup>-4</sup>	0.33×10 <sup>-4</sup>	0.33×10 <sup>-4</sup>	1.35×10 <sup>-4</sup>	1.35×10 <sup>-4</sup>	
	Excitation voltage *4	V	24 VDC±10%							
	Power consumption (at 20°C)	W	17	19	19	19	19	22	22	
	Current consumption (at 20°C)	A	0.70±10%	0.81±10%	0.81±10%	0.81±10%	0.81±10%	0.90±10%	0.90±10%	
	Static friction torque	N • m	2.5 min.	7.8 min.	7.8 min.	7.8 min.	11.8 min.	16.1 min.	16.1 min.	
	Attraction time	ms	50 max.	50 max.	50 max.	50 max.	80 max.	110 max.	110 max.	
	Release time	ms	15 max. *5	15 max. *5	15 max. *5	15 max. *5	15 max. *5	50 max. *6	50 max. *6	
	Backlash		±1°							
	Allowable work per braking	J	392	392	392	392	392	1470	1470	
	Allowable total work	J	4.9×10 <sup>5</sup>	4.9×10 <sup>5</sup>	4.9×10 <sup>5</sup>	4.9×10 <sup>5</sup>	4.9×10 <sup>5</sup>	2.2×10 <sup>6</sup>	2.2×10 <sup>6</sup>	
	Allowable angular acceleration	rad/s <sup>2</sup>	10,000							
	Brake limit	–	10 million times min.							
	Rating	–	Continuous							
Insulation class	–	Type F								

\*1. These are the values when the motor is combined with a driver at normal temperature (20°C, 65%). The momentary maximum torque indicates the standard value.

\*2. Applicable load inertia.

- The operable load inertia ratio (load inertia/rotor inertia) depends on the mechanical configuration and its rigidity. For a machine with high rigidity, operation is possible even with high load inertia. Select an appropriate motor and confirm that operation is possible.
- If the dynamic brake is activated frequently with high load inertia, the Dynamic Brake Resistor may burn. Do not repeatedly turn the servo ON/OFF while the dynamic brake is enabled.
- The dynamic brake is designed only for emergency stops. Design the system so that the Servomotor remains stopped for at least 10 minutes after applying the dynamic brake. Otherwise the dynamic brake circuits may fail.

\*3. The allowable radial and thrust loads are the values determined for a limit of 20,000 hours at normal operating temperatures. The allowable radial loads are applied as shown in the following diagram.

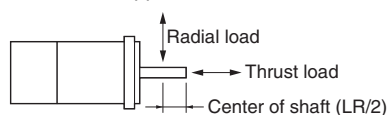

\*4. This is a non-excitation brake. (It is released when excitation voltage is applied.)

\*5. Direct current switching with a varistor (Z15D151 by Ishizuka Electronics Co.).

\*6. Direct current switching with a varistor (TNR9G820K by Nippon Chemi-Con Corporation).

## Torque and Rotation Speed Characteristics 3,000 r/min Servomotors (400 VAC Input Power)

The following graphs show the characteristics with a 3 m standard cable and a 400 VAC input.

- R88M-K75030F/C (750W)

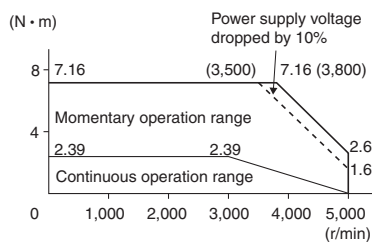

- R88M-K1K030F/C (1kW)

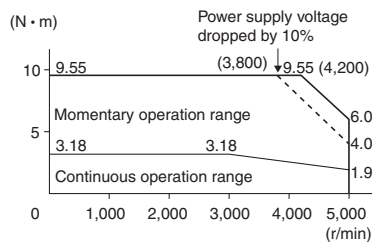

- R88M-K1K530F/C (1.5kW)

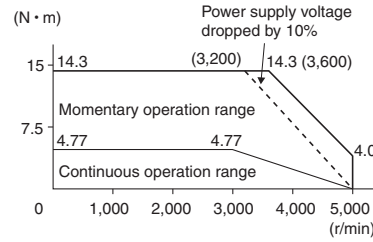

- R88M-K2K030F/C (2kW)

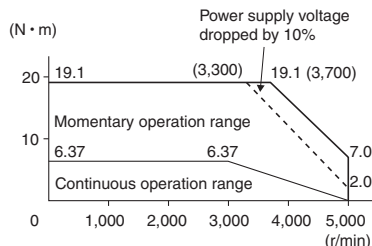

- R88M-K3K030F/C (3kW)

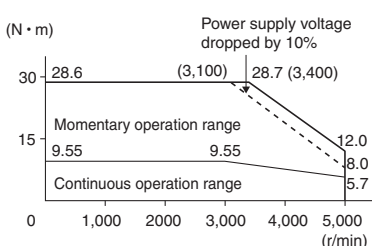

- R88M-K4K030F/C (4kW)

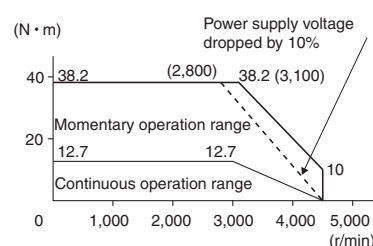

- R88M-K5K030F/C (5kW)

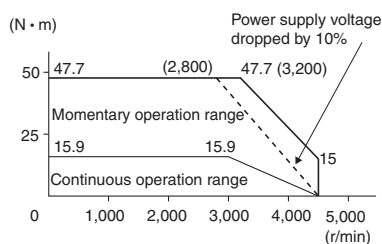

**Note 1:** The continuous operation range is the range in which continuous operation is possible. Continuous operation at the maximum speed is also possible. However, doing so will reduce the output torque.

**Note 2:** If the motor power cable exceeds 20 m, the voltage drop will increase and the momentary operation range will become narrower.

# AC Servomotor/Drive G5-series

## Characteristics

### 1,500 r/min, 2,000 r/min Servomotors (200 VAC Input Power)

Model (R88M-)		K1K020H	K1K520H	K2K020H	K3K020H	K4K020H	K5K020H	—	—	—	
Item	Unit	K1K020T	K1K520T	K2K020T	K3K020T	K4K020T	K5K020T	K7K515T	K11K015T	K15K015T	
Rated output *1	W	1,000	1,500	2,000	3,000	4,000	5,000	7,500	11,000	15,000	
Rated torque *1	N • m	4.77	7.16	9.55	14.3	19.1	23.9	47.8	70.0	95.0	
Rated rotation speed	r/min	2,000						1,500			
Momentary maximum rotation speed	r/min	3,000						3,000	2,000		
Momentary maximum torque *1	N • m	14.3	21.5	28.6	43.0	57.3	71.6	119.0	175.0	224.0	
Rated current *1	A (rms)	5.7	9.4	11.5	17.4	21.0	25.9	44.0	54.2	66.1	
Momentary maximum current *1	A (0-p)	24	40	49	74	89	110	165	203	236	
Rotor inertia	Without brake	kg • m <sup>2</sup>	4.60×10 <sup>-4</sup>	6.70×10 <sup>-4</sup>	8.72×10 <sup>-4</sup>	12.9×10 <sup>-4</sup>	37.6×10 <sup>-4</sup>	48.0×10 <sup>-4</sup>	101×10 <sup>-4</sup>	212×10 <sup>-4</sup>	302×10 <sup>-4</sup>
	With brake	kg • m <sup>2</sup>	5.90×10 <sup>-4</sup>	7.99×10 <sup>-4</sup>	10.0×10 <sup>-4</sup>	14.2×10 <sup>-4</sup>	38.6×10 <sup>-4</sup>	48.8×10 <sup>-4</sup>	107×10 <sup>-4</sup>	220×10 <sup>-4</sup>	311×10 <sup>-4</sup>
Applicable load inertia	—	10 times the rotor inertia max. *2									
Torque constant *1	N • m/A	0.63	0.58	0.64	0.59	0.70	0.70	0.77	0.92	1.05	
Power rate *1	Without brake	kW/s	49.5	76.5	105	159	97.1	119	226	231	302
	With brake	kW/s	38.6	64.2	91.2	144	94.5	117	213	223	293
Mechanical time constant	Without brake	ms	0.80	0.66	0.66	0.57	0.65	0.63	0.58	0.80	0.71
	With brake	ms	1.02	0.80	0.76	0.63	0.66	0.64	0.61	0.83	0.74
Electrical time constant	ms	9.4	10	10	12	20	19	21	31	32	
Allowable radial load *3	N	490	490	490	784	784	784	1,176	2,254	2,254	
Allowable thrust load *3	N	196	196	196	343	343	343	490	686	686	
Weight	Without brake	kg	Approx. 5.2	Approx. 6.7	Approx. 8.0	Approx. 11.0	Approx. 15.5	Approx. 18.6	Approx. 36.4	Approx. 52.7	Approx. 70.2
	With brake	kg	Approx. 6.7	Approx. 8.2	Approx. 9.5	Approx. 12.6	Approx. 18.7	Approx. 21.8	Approx. 40.4	Approx. 58.9	Approx. 76.3
Radiator plate dimensions (material)		275×260×t15 (Al)			380×350×t30 (Al)		470×440×t30 (Al)		550×520×t30 (Al)		670×630×t35 (Al)
Applicable drives (R88D-)		KT10H/ KN10H- ML2/ KN10H- ECT	KT15H/ KN15H- ML2/ KN15H- ECT	KT20H/ KN20H- ML2/ KN20H- ECT	KT30H/ KN30H- ML2/ KN30H- ECT	KT50H/ KN50H- ML2/ KN50H- ECT	KT50H/ KN50H- ML2/ KN50H- ECT	KT75H/ KN75H- ECT	KT150H/ KN150H- ECT	KT150H/ KN150H- ECT	
Brake specifications	Brake inertia	kg • m <sup>2</sup>	1.35×10 <sup>-4</sup>	1.35×10 <sup>-4</sup>	1.35×10 <sup>-4</sup>	1.35×10 <sup>-4</sup>	4.7×10 <sup>-4</sup>	4.7×10 <sup>-4</sup>	4.7×10 <sup>-4</sup>	7.1×10 <sup>-4</sup>	7.1×10 <sup>-4</sup>
	Excitation voltage *4	V	24 VDC±10%								
	Power consumption (at 20°C)	W	14	19	19	22	31	31	34	26	26
	Current consumption (at 20°C)	A	0.59±10%	0.79±10%	0.79±10%	0.90±10%	1.3±10%	1.3±10%	1.4±10%	1.08±10%	1.08±10%
	Static friction torque	N • m	4.9 min.	13.7 min.	13.7 min.	16.2 min.	24.5 min.	24.5 min.	58.8 min.	100 min.	100 min.
	Attraction time	ms	80 max.	100 max.	100 max.	110 max.	80 max.	80 max.	150 max.	300 max.	300 max.
	Release time	ms	70 max. *5	50 max. *5	50 max. *5	50 max. *5	25 max. *6	25 max. *6	50 max. *6	140 max. *7	140 max. *7
	Backlash		±1°								
	Allowable work per braking	J	588	1,176	1,176	1,470	1,372	1,372	1,372	2,000	2,000
	Allowable total work	J	7.8×10 <sup>5</sup>	1.5×10 <sup>6</sup>	1.5×10 <sup>6</sup>	2.2×10 <sup>6</sup>	2.9×10 <sup>6</sup>	2.9×10 <sup>6</sup>	2.9×10 <sup>6</sup>	4.0×10 <sup>6</sup>	4.0×10 <sup>6</sup>
	Allowable angular acceleration	rad/s <sup>2</sup>	10,000						5,000	3,000	
	Brake limit	—	10 million times min.								
	Rating	—	Continuous								
Insulation class	—	Type F									

\*1. These are the values when the motor is combined with a driver at normal temperature (20°C, 65%). The momentary maximum torque indicates the standard value.

\*2. Applicable load inertia.

- The operable load inertia ratio (load inertia/rotor inertia) depends on the mechanical configuration and its rigidity. For a machine with high rigidity, operation is possible even with high load inertia. Select an appropriate motor and confirm that operation is possible.
- If the dynamic brake is activated frequently with high load inertia, the Dynamic Brake Resistor may burn. Do not repeatedly turn the servo ON/OFF while the dynamic brake is enabled.
- The dynamic brake is designed only for emergency stops. Design the system so that the Servomotor remains stopped for at least 10 minutes after applying the dynamic brake. Otherwise the dynamic brake circuits may fail.

\*3. The allowable radial and thrust loads are the values determined for a limit of 20,000 hours at normal operating temperatures. The allowable radial loads are applied as shown in the following diagram.

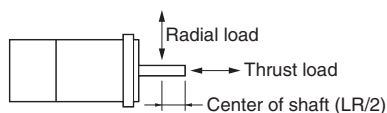

\*4. This is a non-excitation brake. (It is released when excitation voltage is applied.)

\*5. Direct current switching with a varistor (TNR9G820K by Nippon Chemi-Con Corporation).

\*6. Direct current switching with a varistor (Z15D151 by Ishizuka Electronics Co.).

\*7. Direct current switching with a varistor (NVD07SCD082 by KOA SPEER ELECTRONICS, INC.).

## Torque and Rotation Speed Characteristics

### 1,500 r/min, 2,000 r/min Servomotors (200 VAC Input Power)

The following graphs show the characteristics with a 3 m standard cable and a 200 VAC input.

- R88M-K1K020H/T (1kW)

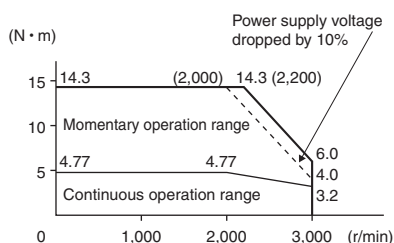

- R88M-K1K520H/T (1.5kW)

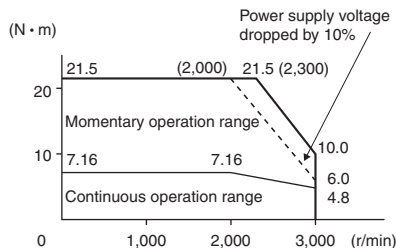

- R88M-K2K020H/T (2kW)

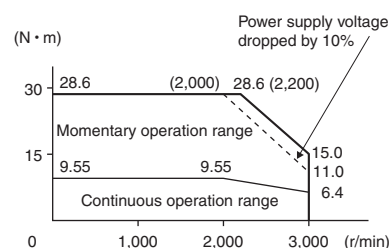

- R88M-K3K020H/T (3kW)

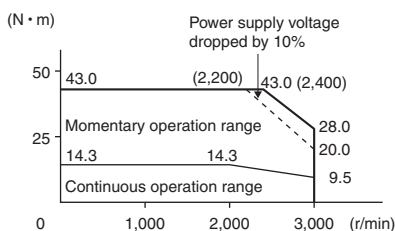

- R88M-K4K020H/T (4kW)

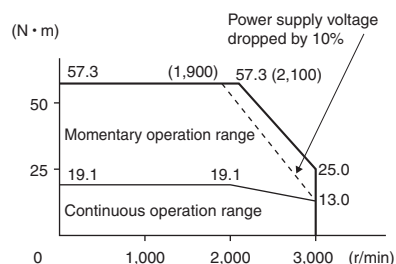

- R88M-K5K020H/T (5kW)

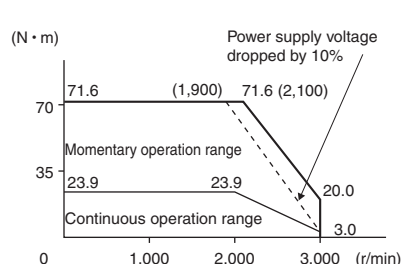

- R88M-K7K515T (7.5kW)

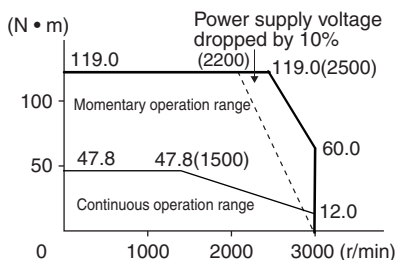

- R88M-K11K015T (11kW)

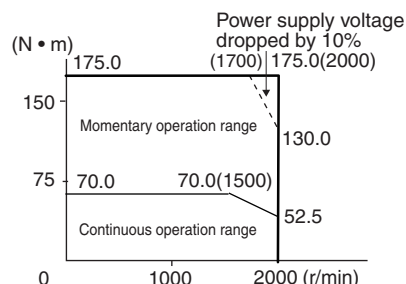

- R88M-K15K015T (15kW)

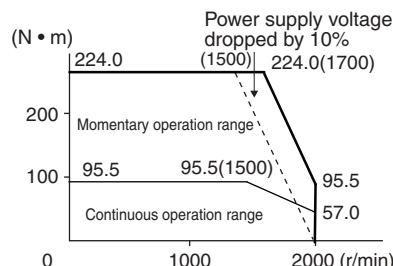

**Note 1:** The continuous operation range is the range in which continuous operation is possible. Continuous operation at the maximum speed is also possible. However, doing so will reduce the output torque.

**Note 2:** If the motor power cable exceeds 20 m, the voltage drop will increase and the momentary operation range will become narrower.

# AC Servomotor/Drive G5-series

## Characteristics

### 1,500 r/min, 2,000 r/min Servomotors (400 VAC Input Power)

Model (R88M-)		K40020F	K60020F	K1K020F	K1K520F	K2K020F	K3K020F	K4K020F	K5K020F	—	—	—		
Item		Unit	K40020C	K60020C	K1K020C	K1K520C	K2K020C	K3K020C	K4K020C	K5K020C	K7K515C	K11K015C	K15K015C	
Rated output *1		W	400	600	1,000	1,500	2,000	3,000	4,000	5,000	7,500	11,000	15,000	
Rated torque *1		N • m	1.91	2.86	4.77	7.16	9.55	14.3	19.1	23.9	47.8	70.0	95.9	
Rated rotation speed		r/min	2,000									1,500		
Momentary maximum rotation speed		r/min	3,000									2,000		
Momentary maximum torque *1		N • m	5.73	8.59	14.3	21.5	28.7	43.0	57.3	71.6	119.0	175.0	224.0	
Rated current *1		A (rms)	1.2	1.5	2.8	4.7	5.9	8.7	10.6	13.0	22.0	27.1	33.1	
Momentary maximum current *1		A (0-p)	4.9	6.5	12	20	25	37	45	55	83	101	118	
Rotor inertia	Without brake	kg • m <sup>2</sup>	1.61×10 <sup>-4</sup>	2.03×10 <sup>-4</sup>	4.60×10 <sup>-4</sup>	6.70×10 <sup>-4</sup>	8.72×10 <sup>-4</sup>	12.9×10 <sup>-4</sup>	37.6×10 <sup>-4</sup>	48.0×10 <sup>-4</sup>	101×10 <sup>-4</sup>	212×10 <sup>-4</sup>	302×10 <sup>-4</sup>	
	With brake	kg • m <sup>2</sup>	1.90×10 <sup>-4</sup>	2.35×10 <sup>-4</sup>	5.90×10 <sup>-4</sup>	7.99×10 <sup>-4</sup>	10.0×10 <sup>-4</sup>	14.2×10 <sup>-4</sup>	38.6×10 <sup>-4</sup>	48.8×10 <sup>-4</sup>	107×10 <sup>-4</sup>	220×10 <sup>-4</sup>	311×10 <sup>-4</sup>	
Applicable load inertia		—	10 times the rotor inertia max. *2											
Torque constant *1		N • m/A	1.27	1.38	1.27	1.16	1.27	1.18	1.40	1.46	1.54	1.84	2.10	
Power rate *1	Without brake	kW/s	22.7	40.3	49.5	76.5	105	159	97.1	119	226	231	302	
	With brake	kW/s	19.2	34.8	38.6	64.2	91.2	144	94.5	117	213	223	293	
Mechanical time constant	Without brake	ms	0.70	0.62	0.79	0.66	0.68	0.56	0.60	0.60	0.58	0.80	0.71	
	With brake	ms	0.83	0.72	1.01	0.79	0.78	0.61	0.61	0.61	0.61	0.83	0.74	
Electrical time constant		ms	5.7	5.9	10	10	10	12	21	19	21	31	32	
Allowable radial load *3		N	490	490	490	490	490	784	784	784	1,176	2,254	2,254	
Allowable thrust load *3		N	196	196	196	196	196	343	343	343	490	686	686	
Weight	Without brake	kg	Approx. 3.1	Approx. 3.5	Approx. 5.2	Approx. 6.7	Approx. 8.0	Approx. 11.0	Approx. 15.5	Approx. 18.6	Approx. 36.4	Approx. 52.7	Approx. 70.2	
	With brake	kg	Approx. 4.1	Approx. 4.5	Approx. 6.7	Approx. 8.2	Approx. 9.5	Approx. 12.6	Approx. 18.7	Approx. 21.8	Approx. 40.4	Approx. 58.9	Approx. 76.3	
Radiator plate dimensions (material)			320×300×t20 (Al)			275×260×t15 (Al)			380×350×t30 (Al)	470×440×t30 (Al)		550×520×t30 (Al)	670×630×t35 (Al)	
Applicable drives (R88D-)			KT06F/ KN06F- ML2/ KN06F- ECT	KT06F/ KN06F- ML2/ KN06F- ECT	KT10F/ KN10F- ML2/ KN10F- ECT	KT15F/ KN15F- ML2/ KN15F- ECT	KT20F/ KN20F- ML2/ KN20F- ECT	KT30F/ KN30F- ML2/ KN30F- ECT	KT50F/ KN50F- ML2/ KN50F- ECT	KT50F/ KN50F- ML2/ KN50F- ECT	KT75F/ KN75F- ECT	KT150F/ KN150F- ECT	KT150F/ KN150F- ECT	
Brake specifications	Brake inertia	kg • m <sup>2</sup>	1.35×10 <sup>-4</sup>	1.35×10 <sup>-4</sup>	1.35×10 <sup>-4</sup>	1.35×10 <sup>-4</sup>	1.35×10 <sup>-4</sup>	1.35×10 <sup>-4</sup>	4.7×10 <sup>-4</sup>	4.7×10 <sup>-4</sup>	4.7×10 <sup>-4</sup>	7.1×10 <sup>-4</sup>	7.1×10 <sup>-4</sup>	
	Excitation voltage *4	V	24 VDC±10%											
	Power consumption (at 20°C)	W	17	17	14	19	19	22	31	31	34	26	26	
	Current consumption (at 20°C)	A	0.70±10%	0.70±10%	0.59±10%	0.79±10%	0.79±10%	0.90±10%	1.3±10%	1.3±10%	1.4±10%	1.08±10%	1.08±10%	
	Static friction torque	N • m	2.5 min.	2.5 min.	4.9 min.	13.7 min.	13.7 min.	16.2 min.	24.5 min.	24.5 min.	58.8 min.	100 min.	100 min.	
	Attraction time	ms	50 max.	50 max.	80 max.	100 max.	100 max.	110 max.	80 max.	80 max.	150 max.	300 max.	300 max.	
	Release time	ms	15 max. *5	15 max. *5	70 max. *6	50 max. *6	50 max. *6	50 max. *6	25 max. *5	25 max. *5	50 max. *5	140 max. *7	140 max. *7	
	Backlash		±1°											
	Allowable work per braking	J	392	392	588	1,176	1,176	1,470	1,372	1,372	1,372	2,000	2,000	
	Allowable total work	J	4.9×10 <sup>5</sup>	4.9×10 <sup>5</sup>	7.8×10 <sup>5</sup>	1.5×10 <sup>6</sup>	1.5×10 <sup>6</sup>	2.2×10 <sup>6</sup>	2.9×10 <sup>6</sup>	2.9×10 <sup>6</sup>	2.9×10 <sup>6</sup>	4.0×10 <sup>6</sup>	4.0×10 <sup>6</sup>	
	Allowable angular acceleration	rad/s <sup>2</sup>	10,000									5,000	3,000	
	Brake limit	—	10 million times min.											
	Rating	—	Continuous											
Insulation class	—	Type F												

\*1. These are the values when the motor is combined with a driver at normal temperature (20°C, 65%). The momentary maximum torque indicates the standard value.

\*2. Applicable load inertia.

- The operable load inertia ratio (load inertia/rotor inertia) depends on the mechanical configuration and its rigidity. For a machine with high rigidity, operation is possible even with high load inertia. Select an appropriate motor and confirm that operation is possible.
- If the dynamic brake is activated frequently with high load inertia, the Dynamic Brake Resistor may burn. Do not repeatedly turn the servo ON/OFF while the dynamic brake is enabled.
- The dynamic brake is designed only for emergency stops. Design the system so that the Servomotor remains stopped for at least 10 minutes after applying the dynamic brake. Otherwise the dynamic brake circuits may fail.

\*3. The allowable radial and thrust loads are the values determined for a limit of 20,000 hours at normal operating temperatures. The allowable radial loads are applied as shown in the following diagram.

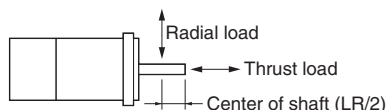

\*4. This is a non-excitation brake. (It is released when excitation voltage is applied.)

\*5. Direct current switching with a varistor (Z15D151 by Ishizuka Electronics Co.).

\*6. Direct current switching with a varistor (TNR9G820K by Nippon Chemi-Con Corporation).

\*7. Direct current switching with a varistor (NVD07SCD082 by KOA SPEER ELECTRONICS, INC.).

## Torque and Rotation Speed Characteristics

### 1,500 r/min, 2,000 r/min Servomotors (400 VAC Input Power)

The following graphs show the characteristics with a 3 m standard cable and a 400 VAC input.

- R88M-K40020F/C (400W)

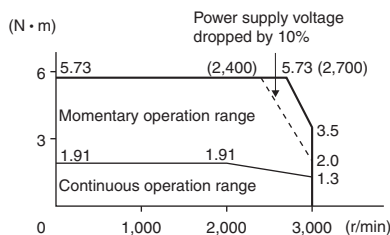

- R88M-K60020F/C (600W)

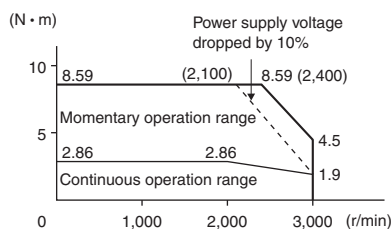

- R88M-K1K020F/C (1kW)

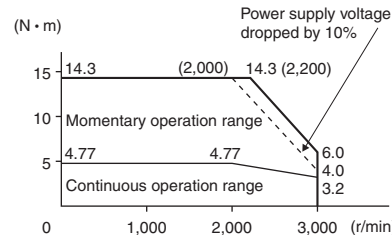

- R88M-K1K520F/C (1.5kW)

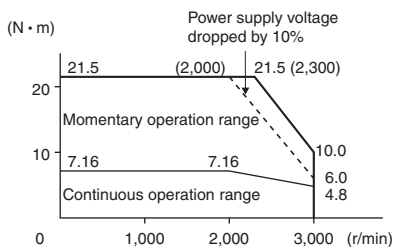

- R88M-K2K020F/C (2kW)

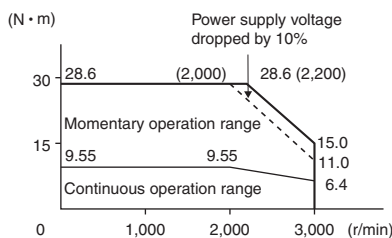

- R88M-K3K020F/C (3kW)

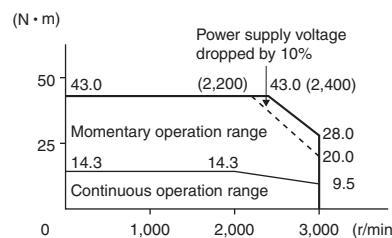

- R88M-K4K020F/C (4kW)

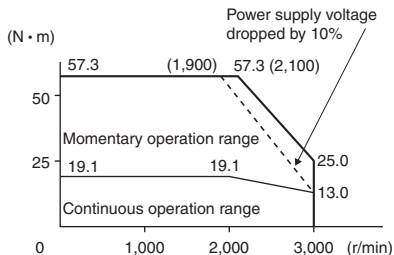

- R88M-K5K020F/C (5kW)

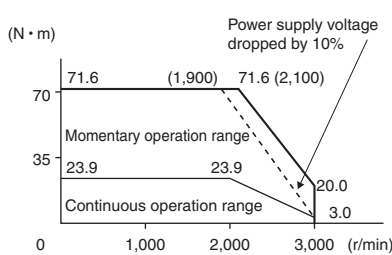

- R88M-K7K515C (7.5kW)

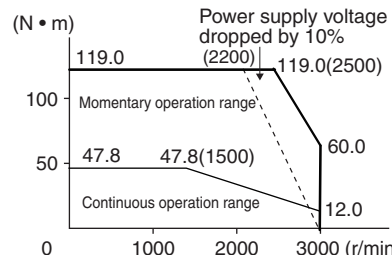

- R88M-K11K015C (11kW)

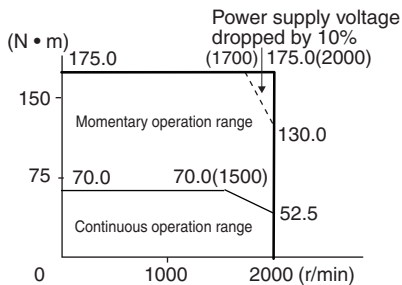

- R88M-K15K015C (15kW)

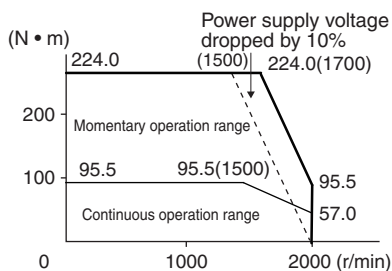

**Note 1:** The continuous operation range is the range in which continuous operation is possible. Continuous operation at the maximum speed is also possible. However, doing so will reduce the output torque.

**Note 2:** If the motor power cable exceeds 20 m, the voltage drop will increase and the momentary operation range will become narrower.

# AC Servomotor/Drive G5-series

## Characteristics

### 1,000 r/min Servomotors (200/400 VAC Input Power)

Model (R88M-)		200 VAC					400 VAC					
		K90010H	K2K010H	K3K010H	–	–	K90010F	K2K010F	K3K010F	–	–	
Item	Unit	K90010T	K2K010T	K3K010T	K4K510T	K6K010T	K90010C	K2K010C	K3K010C	K4K510C	K6K010C	
Rated output *1	W	900	2,000	3,000	4,500	6,000	900	2,000	3,000	4,500	6,000	
Rated torque *1	N • m	8.59	19.1	28.7	43.0	57.0	8.59	19.1	28.7	43.0	57.3	
Rated rotation speed	r/min	1,000										
Momentary maximum rotation speed	r/min	2,000										
Momentary maximum torque *1	N • m	19.3	47.7	71.7	107.0	143.0	19.3	47.7	71.7	107.0	143.0	
Rated current *1	A (rms)	7.6	17.0	22.6	29.7	38.8	3.8	8.5	11.3	14.8	19.4	
Momentary maximum current *1	A (0-p)	24	60	80	110	149	12	30	40	55	74	
Rotor inertia	Without brake	kW/s	6.70×10 <sup>-4</sup>	30.3×10 <sup>-4</sup>	48.4×10 <sup>-4</sup>	79.1×10 <sup>-4</sup>	101×10 <sup>-4</sup>	6.70×10 <sup>-4</sup>	30.3×10 <sup>-4</sup>	48.4×10 <sup>-4</sup>	79.1×10 <sup>-4</sup>	101×10 <sup>-4</sup>
	With brake	kW/s	7.99×10 <sup>-4</sup>	31.4×10 <sup>-4</sup>	49.2×10 <sup>-4</sup>	84.4×10 <sup>-4</sup>	107×10 <sup>-4</sup>	7.99×10 <sup>-4</sup>	31.4×10 <sup>-4</sup>	49.2×10 <sup>-4</sup>	84.4×10 <sup>-4</sup>	107×10 <sup>-4</sup>
Applicable load inertia	–	10 times the rotor inertia max. *2										
Torque constant *1	N • m/A	0.86	0.88	0.96	1.02	1.04	1.72	1.76	1.92	2.05	2.08	
Power rate *1	Without brake	kW/s	110	120	170	233	325	110	120	170	233	325
	With brake	kW/s	92.4	116	167	219	307	92.4	116	167	219	307
Mechanical time constant	Without brake	ms	0.66	0.75	0.63	0.55	0.54	0.66	0.76	0.61	0.55	0.54
	With brake	ms	0.78	0.78	0.64	0.63	0.57	0.79	0.78	0.62	0.63	0.57
Electrical time constant	ms	11	18	21	20	23	11	18	22	20	23	
Allowable radial load *3	N	686	1176	1470	1470	1764	686	1176	1470	1470	1764	
Allowable thrust load *3	N	196	490	490	490	588	196	490	490	490	588	
Weight	Without brake	kg	Approx. 6.7	Approx. 14.0	Approx. 20.0	Approx. 29.4	Approx. 36.4	Approx. 6.7	Approx. 14.0	Approx. 20.0	Approx. 29.4	Approx. 36.4
	With brake	kg	Approx. 8.2	Approx. 17.5	Approx. 23.5	Approx. 33.3	Approx. 40.4	Approx. 8.2	Approx. 17.5	Approx. 23.5	Approx. 33.3	Approx. 40.4
Radiator plate dimensions (material)		270×260×115 (Al)			470×440×t30 (Al)	550×520×t30 (Al)	270×260×t15 (Al)	470×440×t30 (Al)			550×520×t30 (Al)	
Applicable drives (R88D-)		KT15H/ KN15H- ML2/ KN15H- ECT	KT30H/ KN30H- ML2/ KN30HF- ECT	KT50H/ KN50H- ML2/ KN50H- ECT	KT50H/ KN50H- ECT	KT75H/ KN75H- ECT	KT15F/ KN15F- ML2/ KN15F- ECT	KT30F/ KN30F- ML2/ KN30F- ECT	KT50F/ KN50F- ML2/ KN50F- ECT	KT50F/ KN50F- ECT	KT75F/ KN75F- ECT	
Brake specifications	Brake inertia	kg • m <sup>2</sup>	1.35×10 <sup>-4</sup>	4.7×10 <sup>-4</sup>	4.7×10 <sup>-4</sup>	4.7×10 <sup>-4</sup>	4.7×10 <sup>-4</sup>	1.35×10 <sup>-4</sup>	4.7×10 <sup>-4</sup>	4.7×10 <sup>-4</sup>	4.7×10 <sup>-4</sup>	4.7×10 <sup>-4</sup>
	Excitation voltage *4	V	24 VDC±10%									
	Power consumption (at 20°C)	W	19	31	34	34	34	19	31	34	34	34
	Current consumption (at 20°C)	A	0.79±10%	1.3±10%	1.4±10%	1.4±10%	1.4±10%	0.79±10%	1.3±10%	1.4±10%	1.4±10%	1.4±10%
	Static friction torque	N • m	13.7 min.	24.5 min.	58.8 min.	58.8 min.	58.8 min.	13.7 min.	24.5 min.	58.8 min.	58.8 min.	58.8 min.
	Attraction time	ms	100 max.	80 max.	150 max.	150 max.	150 max.	100 max.	80 max.	150 max.	150 max.	150 max.
	Release time	ms	50 max. *5	25 max. *6	50 max. *6	50 max. *6	50 max. *6	50 max. *5	25 max. *6	50 max. *6	50 max. *6	50 max. *6
	Backlash		±1°									
	Allowable work per braking	J	1,176	1,372	1,372	1,372	1,372	1,176	1,372	1,372	1,372	1,372
	Allowable total work	J	1.5×10 <sup>6</sup>	2.9×10 <sup>6</sup>	2.9×10 <sup>6</sup>	2.9×10 <sup>6</sup>	2.9×10 <sup>6</sup>	1.5×10 <sup>6</sup>	2.9×10 <sup>6</sup>	2.9×10 <sup>6</sup>	2.9×10 <sup>6</sup>	2.9×10 <sup>6</sup>
	Allowable angular acceleration	rad/s <sup>2</sup>	10,000			5,000		10,000			5,000	
	Brake limit	–	10 million times min.									
Rating	–	Continuous										
Insulation class	–	Type F										

\*1. These are the values when the motor is combined with a driver at normal temperature (20°C, 65%). The momentary maximum torque indicates the standard value.

\*2. Applicable load inertia.

- The operable load inertia ratio (load inertia/rotor inertia) depends on the mechanical configuration and its rigidity. For a machine with high rigidity, operation is possible even with high load inertia. Select an appropriate motor and confirm that operation is possible.
- If the dynamic brake is activated frequently with high load inertia, the Dynamic Brake Resistor may burn. Do not repeatedly turn the servo ON/OFF while the dynamic brake is enabled.
- The dynamic brake is designed only for emergency stops. Design the system so that the Servomotor remains stopped for at least 10 minutes after applying the dynamic brake. Otherwise the dynamic brake circuits may fail.

\*3. The allowable radial and thrust loads are the values determined for a limit of 20,000 hours at normal operating temperatures. The allowable radial loads are applied as shown in the following diagram.

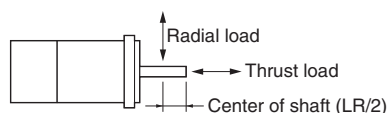

\*4. This is a non-excitation brake. (It is released when excitation voltage is applied.)

\*5. Direct current switching with a varistor (TNR9G820K by Nippon Chemi-Con Corporation).

\*6. Direct current switching with a varistor (Z15D151 by Ishizuka Electronics Co.).

## Torque and Rotation Speed Characteristics 1,000 r/min Servomotors (200/400 VAC Input Power)

The following graphs show the characteristics with a 3 m standard cable and a 200 VAC input.

- R88M-K90010H/T/F/C (900W)

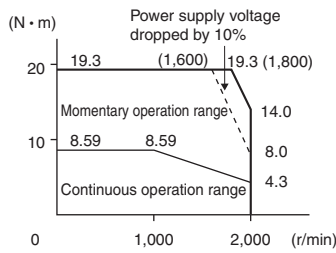

- R88M-K2K010H/T/F/C (2kW)

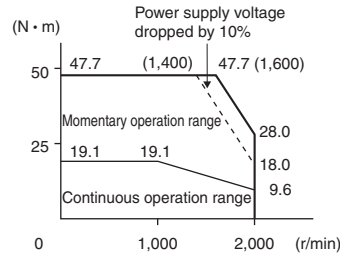

- R88M-K3K010H/T/F/C (3kW)

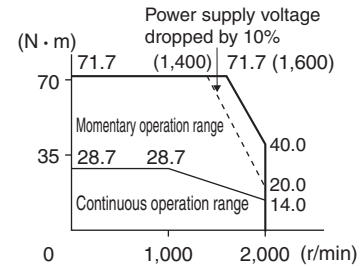

- R88M-K4K510T/C (4.5kW)

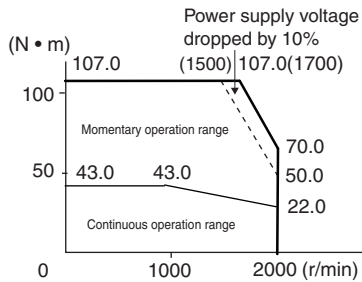

- R88M-K6K010T/C (6kW)

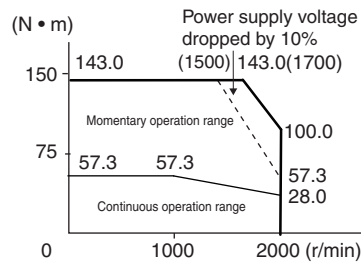

**Note 1:** The continuous operation range is the range in which continuous operation is possible. Continuous operation at the maximum speed is also possible. However, doing so will reduce the output torque.

**Note 2:** If the motor power cable exceeds 20 m, the voltage drop will increase and the momentary operation range will become narrower.

## Encoder Specifications

### Incremental Encoders

Item	Specifications
Encoder system	Optical encoder 20 bits
No. of output pulses	Phases A and B: 262,144 pulses/rotation Phase Z: 1 pulse/rotation
Power supply voltage	5 VDC±5%
Power supply current	180 mA (max.)
Output signals	+S, -S
Output interface	RS-485 compliance

### Absolute Encoders

Item	Specifications
Encoder system	Optical encoder 17 bits
No. of output pulses	Phases A and B: 32,768 pulses/rotation Phase Z: 1 pulse/rotation
Maximum rotations	-32,768 to +32,767 rotations
Power supply voltage	5 VDC±5%
Power supply current	150 mA (max.)
Applicable battery voltage	3.6 VDC
Current consumption of battery	265 μA for a maximum of 5 s right after power interruption 100 μA for operation during power interruption 3.6 μA when power is supplied to Servo Drive
Output signals	+S, -S
Output interface	RS-485 compliance

**Note: Multi-rotation Data Backup**

- The multi-rotation data will be lost if the battery cable connector is disconnected at the motor when connecting the battery cable for the absolute encoder and battery.
- The multi-rotation data will be lost if CN2 is disconnected when connecting the battery to CN1 without the use of a battery cable for the absolute encoder.

G5-Series  
System Configuration

EtherCAT Communications  
AC Servo Drive

EtherCAT Communications  
Linear Motor Type  
AC Servo Drive

General-purpose Inputs  
AC Servo Drive

ML-II Type  
AC Servo Drive

AC Servomotors

Linear Motor

Decelerator

# AC Servomotor/Drive G5-series

## Dimensions

<Cylinder type>

### 3,000 r/min Servomotors (100/200 VAC)

50W/100W

• Without brake

- R88M-K05030H (-S2)/-K10030□ (-S2) **INC**
- R88M-K05030T (-S2)/-K10030□ (-S2) **ABS**

Model	Dimensions (mm)		
	LL	LM	LN
R88M-K05030□	72	48	23
R88M-K10030□	92	68	43

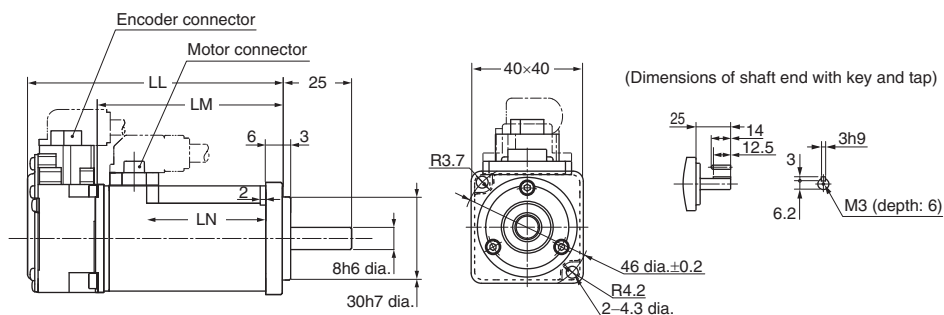

• With brake

- R88M-K05030H-B (S2)/-K10030□-B (S2) **INC**
- R88M-K05030T-B (S2)/-K10030□-B (S2) **ABS**

Model	Dimensions (mm)		
	LL	LM	LN
R88M-K05030□-B□	102	78	23
R88M-K10030□-B□	122	98	43

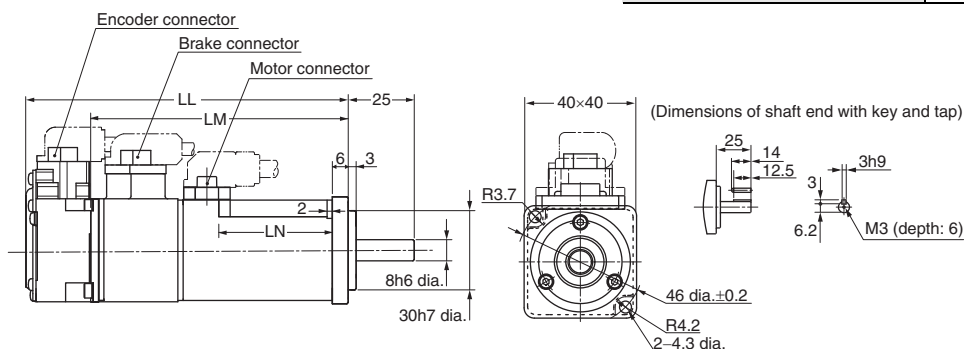

200W/400W

• Without brake

- R88M-K20030□ (-S2)/-K40030□ (-S2) **INC**
- R88M-K20030□ (-S2)/-K40030□ (-S2) **ABS**

Model	Dimensions (mm)		
	LL	LM	LN
R88M-K20030□	79.5	56.5	11
R88M-K40030□	99	76	14

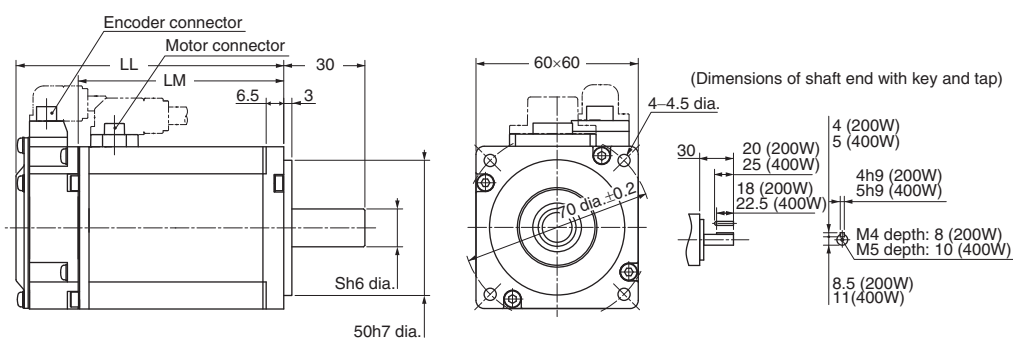

**Note:** The standard models have a straight shaft. A model with a key and tap is indicated by adding "S2" to the end of the model number. Models with an oil seal are indicated with O at the end of the model number. The motor dimensions do not change.

• **With brake**

- R88M-K20030□-B (S2)/-K40030□-B (S2) **INC**
- R88M-K20030□-B (S2)/-K40030□-B (S2) **ABS**

Model	Dimensions (mm)		
	LL	LM	S
R88M-K20030□-B□	116	93	11
R88M-K40030□-B□	135.5	112.5	14

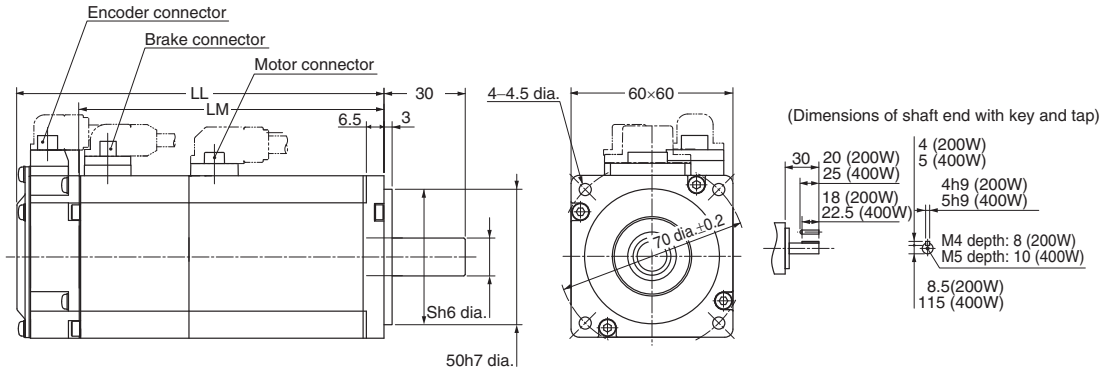

**750W**

• **Without brake**

- R88M-K75030H (-S2) **INC**
- R88M-K75030T (-S2) **ABS**

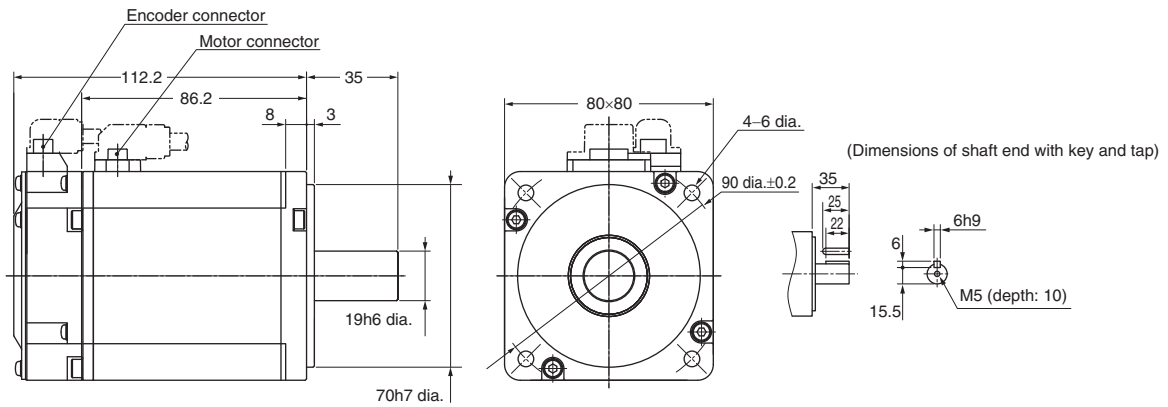

• **With brake**

- R88M-K75030H-B (S2) **INC**
- R88M-K75030T-B (S2) **ABS**

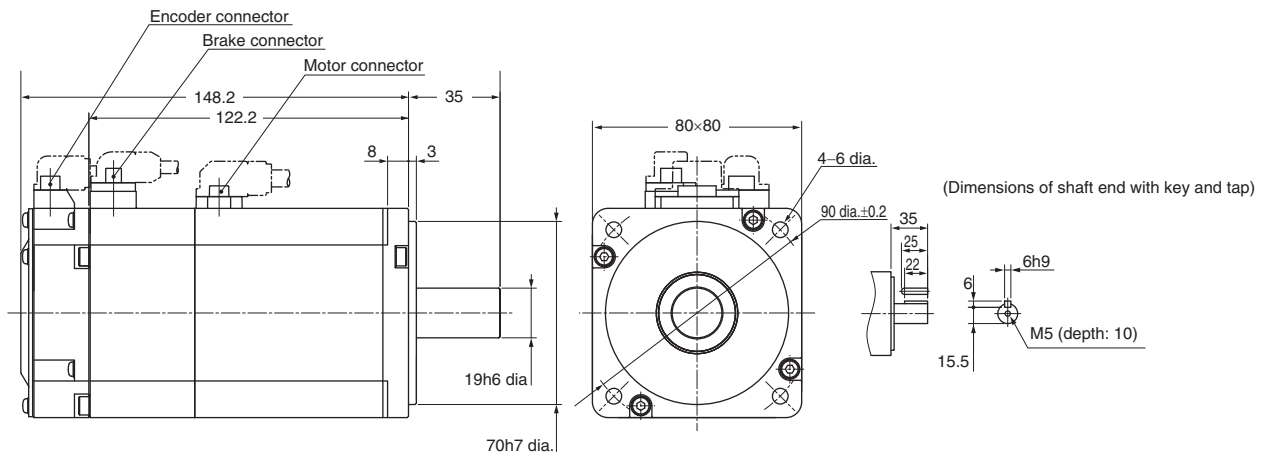

**Note:** The standard models have a straight shaft. A model with a key and tap is indicated by adding "S2" to the end of the model number. Models with an oil seal are indicated with O at the end of the model number. The motor dimensions do not change.

# AC Servomotor/Drive G5-series

## 1kW/1.5kW/2kW

### • Without brake

- R88M-K1K030H (-S2)/-K1K530H (-S2)/-K2K030H (-S2) **INC**
- R88M-K1K030T (-S2)/-K1K530T (-S2)/-K2K030T (-S2) **ABS**

### • With brake

- R88M-K1K030H-B (S2)/-K1K530H-B (S2)/-K2K030H-B (S2) **INC**
- R88M-K1K030T-B (S2)/-K1K530T-B (S2)/-K2K030T-B (S2) **ABS**

Model	Dimensions (mm)			
	LL	LM	KB1	KB2
R88M-K1K030□	141	97	66	119
R88M-K1K530□	159.5	115.5	84.5	137.5
R88M-K2K030□	178.5	134.5	103.5	156.5
R88M-K1K030□-B□	168	124	66	146
R88M-K1K530□-B□	186.5	142.5	84.5	164.5
R88M-K2K030□-B□	205.5	161.5	103.5	183.5

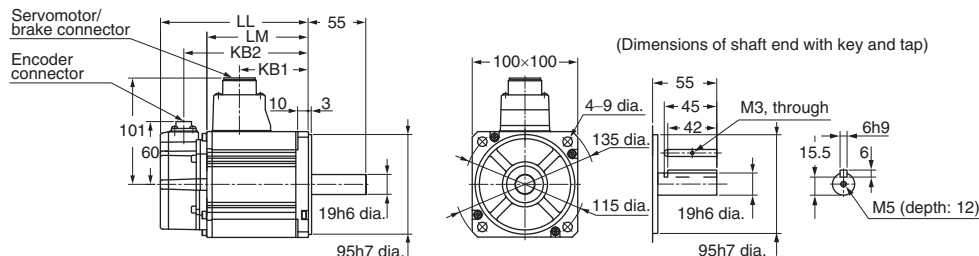

## 3kW

### • Without brake

- R88M-K3K030H (-S2) **INC**
- R88M-K3K030T (-S2) **ABS**

### • With brake

- R88M-K3K030H-B (S2) **INC**
- R88M-K3K030T-B (S2) **ABS**

Model	Dimensions (mm)		
	LL	LM	KB2
R88M-K3K030□	190	146	168
R88M-K3K030□-B□	215	171	193

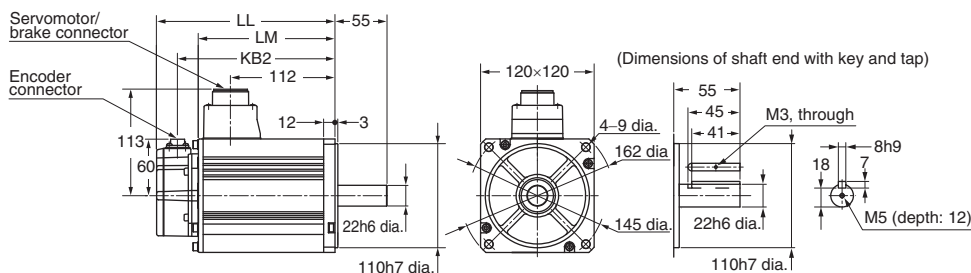

## 4kW/5kW

### • Without brake

- R88M-K4K030H (-S2)/-K5K030H (-S2) **INC**
- R88M-K4K030T (-S2)/-K5K030T (-S2) **ABS**

### • With brake

- R88M-K4K030H-B (S2)/-K5K030H-B (S2) **INC**
- R88M-K4K030T-B (S2)/-K5K030T-B (S2) **ABS**

Model	Dimensions (mm)			
	LL	LM	KB1	KB2
R88M-K4K030□	208	164	127	186
R88M-K5K030□	243	199	162	221
R88M-K4K030□-B□	236	192	127	214
R88M-K5K030□-B□	271	227	162	249

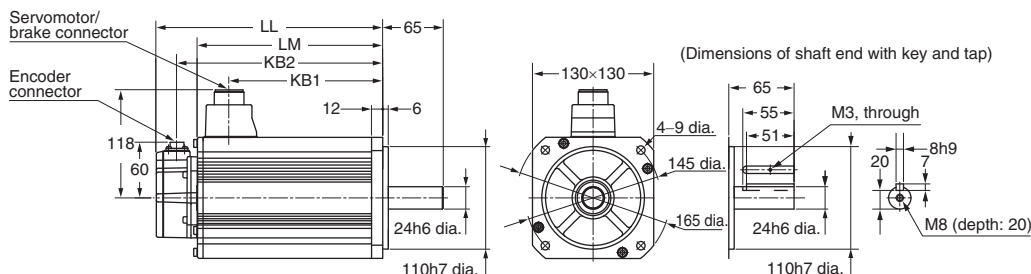

**Note:** The standard models have a straight shaft. A model with a key and tap is indicated by adding "S2" to the end of the model number. Models with an oil seal are indicated with O at the end of the model number. The motor dimensions do not change.

### 3,000 r/min Servomotors (400 VAC)

750W/1kW/1.5kW/2kW

• Without brake

- R88M-K75030F (-S2)/-K1K030F (-S2)/-K1K530F (-S2)/-K2K030F (-S2) **INC**
- R88M-K75030C (-S2)/-K1K030C (-S2)/-K1K530C (-S2)/-K2K030C (-S2) **ABS**

• With brake

- R88M-K75030F-B (S2)/-K1K030F-B (S2)/-K1K530F-B (S2)/-K2K030F-B (S2) **INC**
- R88M-K75030C-B (S2)/-K1K030C-B (S2)/-K1K530C-B (S2)/-K2K030C-B (S2) **ABS**

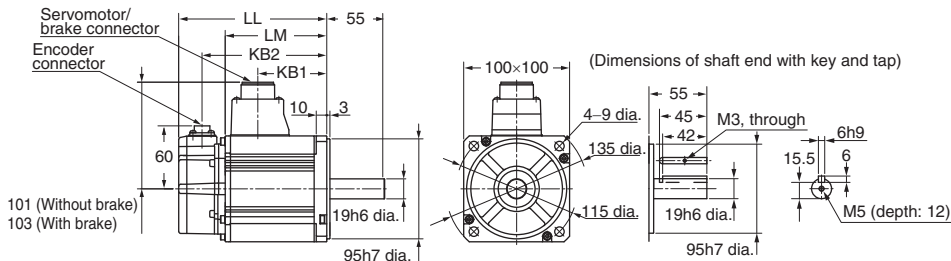

Model	Dimensions (mm)			
	LL	LM	KB1	KB2
R88M-K75030□	131.5	87.5	56.5	109.5
R88M-K1K030□	141	97	66	119
R88M-K1K530□	159.5	115.5	84.5	137.5
R88M-K2K030□	178.5	134.5	103.5	156.5
R88M-K75030□-B□	158.5	114.5	53.5	136.5
R88M-K1K030□-B□	168	124	63	146
R88M-K1K530□-B□	186.5	142.5	81.5	164.5
R88M-K2K030□-B□	205.5	161.5	100.5	183.5

### 3kW

• Without brake

- R88M-K3K030F (-S2) **INC**
- R88M-K3K030C (-S2) **ABS**

• With brake

- R88M-K3K030F-B (S2) **INC**
- R88M-K3K030C-B (S2) **ABS**

Model	Dimensions (mm)		
	LL	LM	KB2
R88M-K3K030□	190	146	168
R88M-K3K030□-B□	215	171	193

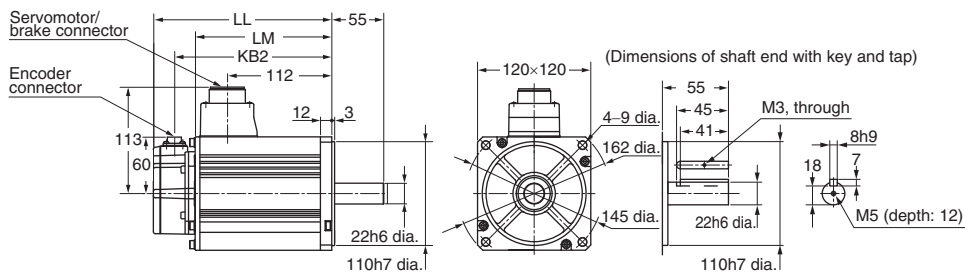

**Note:** The standard models have a straight shaft. A model with a key and tap is indicated by adding "S2" to the end of the model number. Models with an oil seal are indicated with O at the end of the model number. The motor dimensions do not change.

# AC Servomotor/Drive G5-series

## 4kW/5kW

### • Without brake

- R88M-K4K030F (-S2)/-K5K030F (-S2) **INC**
- R88M-K4K030C (-S2)/-K5K030C (-S2) **ABS**

### • With brake

- R88M-K4K030F-B (S2)/-K5K030F-B (S2) **INC**
- R88M-K4K030C-B (S2)/-K5K030C-B (S2) **ABS**

Model	Dimensions (mm)			
	LL	LM	KB1	KB2
R88M-K4K030□	208	164	127	186
R88M-K5K030□	243	199	162	221
R88M-K4K030□-B□	236	192	127	214
R88M-K5K030□-B□	271	227	162	249

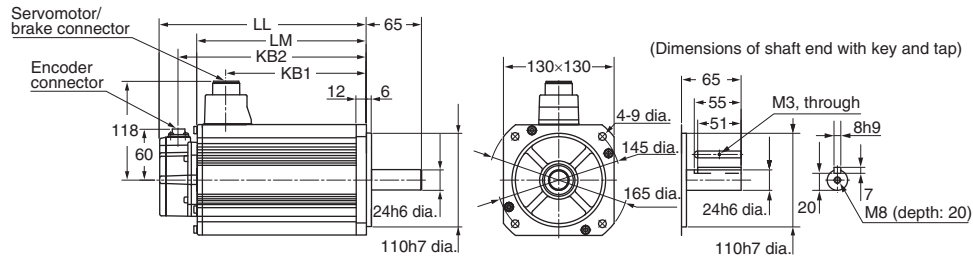

**Note:** The standard models have a straight shaft. A model with a key and tap is indicated by adding "S2" to the end of the model number. Models with an oil seal are indicated with O at the end of the model number. The motor dimensions do not change.

1,500r/min, 2,000 r/min Servomotors (200 VAC)

1kW/1.5kW/2kW/3kW

• Without brake

- R88M-K1K020H (-S2)/-K1K520H (-S2)/-K2K020H (-S2)/-K3K020H (-S2) **INC**
- R88M-K1K020T (-S2)/-K1K520T (-S2)/-K2K020T (-S2)/-K3K020T (-S2) **ABS**

• With brake

- R88M-K1K020H-B (S2)/-K1K520H-B (S2)/-K2K020H-B (S2)/-K3K020H-B (S2) **INC**
- R88M-K1K020T-B (S2)/-K1K520T-B (S2)/-K2K020T-B (S2)/-K3K020T-B (S2) **ABS**

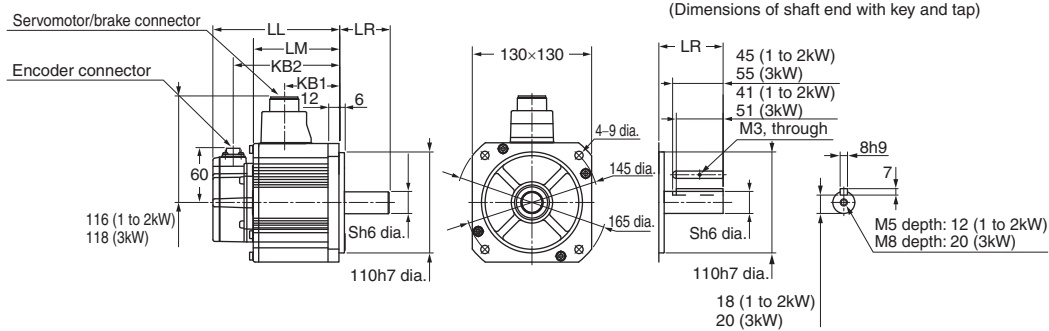

Model	Dimensions (mm)					
	LL	LR	LM	S	KB1	KB2
R88M-K1K020□	138	55	94	22	60	116
R88M-K1K520□	155.5	55	111.5	22	77.5	133.5
R88M-K2K020□	173	55	129	22	95	151
R88M-K3K020□	208	65	164	24	127	186
R88M-K1K020□-B□	166	55	122	22	60	144
R88M-K1K520□-B□	183.5	55	139.5	22	77.5	161.5
R88M-K2K020□-B□	201	55	157	22	95	179
R88M-K3K020□-B□	236	65	192	24	127	214

4kW/5kW

• Without brake

- R88M-K4K020H (-S2)/-K5K020H (-S2) **INC**
- R88M-K4K020T (-S2)/-K5K020T (-S2) **ABS**

• With brake

- R88M-K4K020H-B (S2)/-K5K020H-B (S2) **INC**
- R88M-K4K020T-B (S2)/-K5K020T-B (S2) **ABS**

Model	Dimensions (mm)			
	LL	LM	KB1	KB2
R88M-K4K020□	177	133	96	155
R88M-K5K020□	196	152	115	174
R88M-K4K020□-B□	206	162	96	184
R88M-K5K020□-B□	225	181	115	203

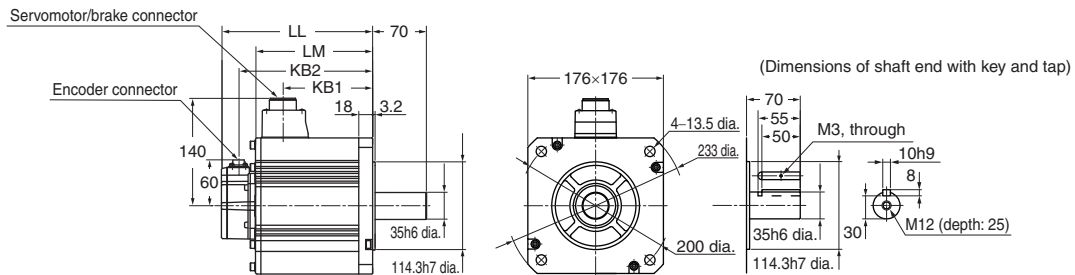

**Note:** The standard models have a straight shaft. A model with a key and tap is indicated by adding "S2" to the end of the model number. Models with an oil seal are indicated with O at the end of the model number. The motor dimensions do not change.

G5-Series  
System Configuration

EtherCAT Communications  
AC Servo Drive

EtherCAT Communications  
Linear Motor Type  
AC Servo Drive

General-purpose Inputs  
AC Servo Drive

ML-II Type  
AC Servo Drive

AC Servomotors

Linear Motor

Decelerator

# AC Servomotor/Drive G5-series

7.5kW

• Without brake

- R88M-K7K515T (-S2) **ABS**

• With brake

- R88M-K7K515T-B (S2) **ABS**

Model	Dimensions (mm)								
	LL	LR	LM	S	KB1	KB2	L1	L2	L3
R88M-K7K515T□	312	113	268	42	219	290	117.5	117.5	149
R88M-K7K515T-B□	337	113	293	42	253	315	117.5	152.5	183

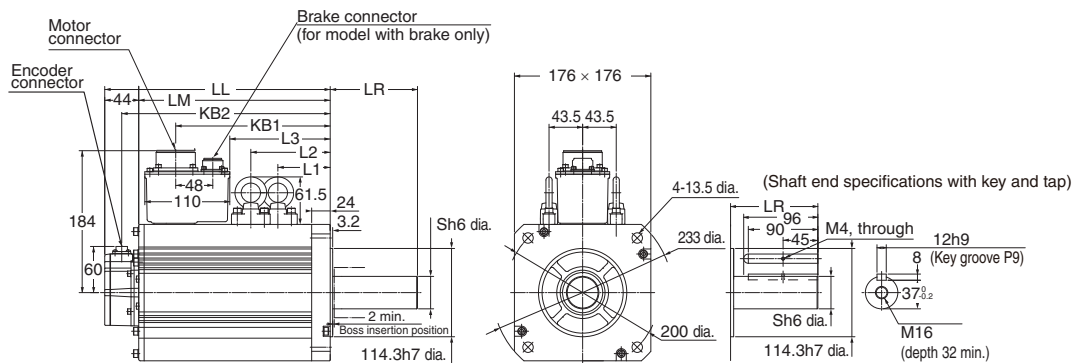

11kW/15kW

• Without brake

- R88M-K11K015T (-S2)/-K15K015T (-S2) **ABS**

• With brake

- R88M-K11K015T-B (S2)/R88M-K15K015T-B (S2) **ABS**

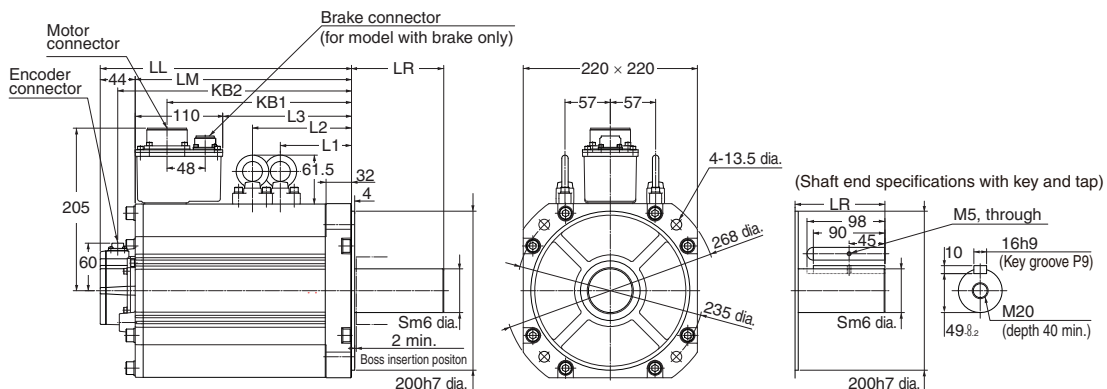

Model	Dimensions (mm)								
	LL	LR	LM	S	KB1	KB2	L1	L2	L3
R88M-K11K015T□	316	116	272	55	232	294	124.5	124.5	162
R88M-K15K015T□	384	116	340	55	300	362	158.5	158.5	230
R88M-K11K015T-B□	364	116	320	55	266	342	124.5	159.5	196
R88M-K15K015T-B□	432	116	388	55	334	410	158.5	193.5	264

**Note:** The standard models have a straight shaft. A model with a key and tap is indicated by adding "S2" to the end of the model number. Models with an oil seal are indicated with O at the end of the model number. The motor dimensions do not change.

1,500 r/min, 2,000 r/min Servomotors (400 VAC)

400W/600W

• Without brake

- R88M-K40020F (-S2)/-K60020F (-S2) **INC**
- R88M-K40020C (-S2)/-K60020C (-S2) **ABS**

• With brake

- R88M-K40020F-B (S2)/-K60020F-B (S2) **INC**
- R88M-K40020C-B (S2)/-K60020C-B (S2) **ABS**

Model	Dimensions (mm)			
	LL	LM	KB1	KB2
R88M-K40020□	131.5	87.5	56.5	109.5
R88M-K60020□	141	97	66	119
R88M-K40020□-B□	158.5	114.5	53.5	136.5
R88M-K60020□-B□	168	124	63	146

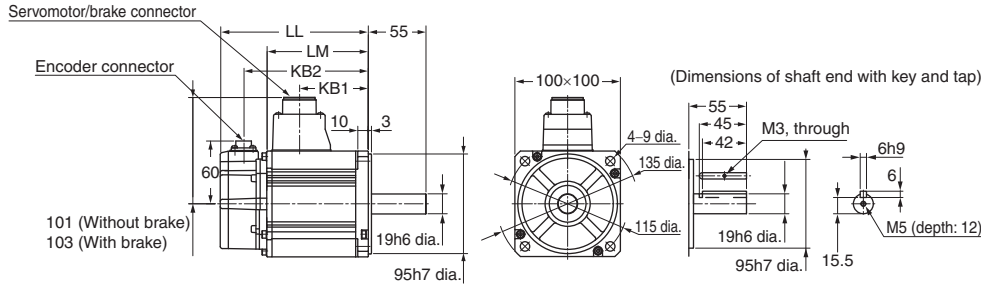

1kW/1.5kW/2kW/3kW

• Without brake

- R88M-K1K020F (-S2)/-K1K520F (-S2)/-K2K020F (-S2)/-K3K020F (-S2) **INC**
- R88M-K1K020C (-S2)/-K1K520C (-S2)/-K2K020C (-S2)/-K3K020C (-S2) **ABS**

• With brake

- R88M-K1K020F-B (S2)/-K1K520F-B (S2)/-K2K020F-B (S2)/-K3K020F-B (S2) **INC**
- R88M-K1K020C-B (S2)/-K1K520C-B (S2)/-K2K020C-B (S2)/-K3K020C-B (S2) **ABS**

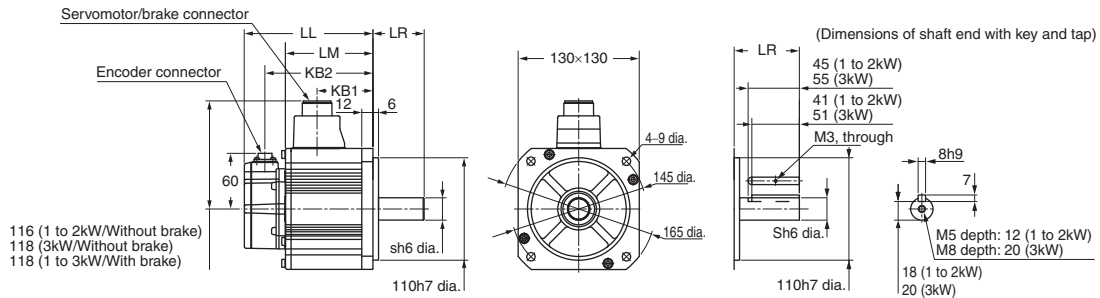

Model	Dimensions (mm)					
	LL	LR	LM	S	KB1	KB2
R88M-K1K020□	138	55	94	22	60	116
R88M-K1K520□	155.5	55	111.5	22	77.5	133.5
R88M-K2K020□	173	55	129	22	95	151
R88M-K3K020□	208	65	164	24	127	186
R88M-K1K020□-B□	166	55	122	22	57	144
R88M-K1K520□-B□	183.5	55	139.5	22	74.5	161.5
R88M-K2K020□-B□	201	55	157	22	92	179
R88M-K3K020□-B□	236	65	192	24	127	214

**Note:** The standard models have a straight shaft. A model with a key and tap is indicated by adding "S2" to the end of the model number. Models with an oil seal are indicated with O at the end of the model number. The motor dimensions do not change.

G5-Series  
System Configuration

EtherCAT Communications  
AC Servo Drive

EtherCAT Communications  
Linear Motor Type  
AC Servo Drive

General-purpose Inputs  
AC Servo Drive

ML-II Type  
AC Servo Drive

AC Servomotors

Linear Motor

Decelerator

# AC Servomotor/Drive G5-series

## 4kW/5kW

### • Without brake

- R88M-K4K020F (-S2)/-K5K020F (-S2) **INC**
- R88M-K4K020C (-S2)/-K5K020C (-S2) **ABS**

### • With brake

- R88M-K4K020F-B (S2)/-K5K020F-B (S2) **INC**
- R88M-K4K020C-B (S2)/-K5K020C-B (S2) **ABS**

Model	Dimensions (mm)			
	LL	LM	KB1	KB2
<b>R88M-K4K020□</b>	177	133	96	155
<b>R88M-K5K020□</b>	196	152	115	174
<b>R88M-K4K020□-B□</b>	206	162	96	184
<b>R88M-K5K020□-B□</b>	225	181	115	203

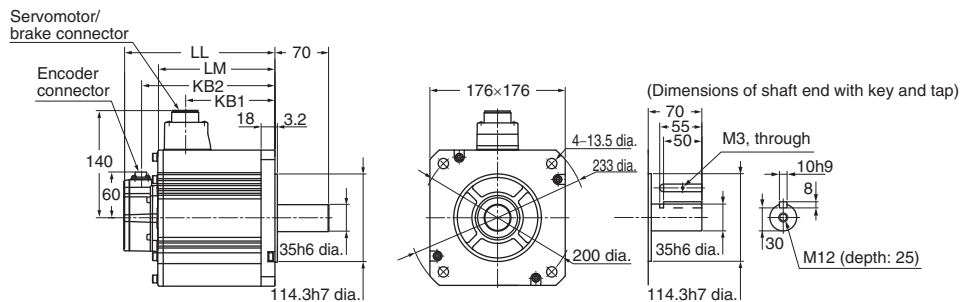

## 7.5kW

### • Without brake

- R88M-K7K515C (-S2) **ABS**

### • With brake

- R88M-K7K515C-B (S2) **ABS**

Model	Dimensions (mm)								
	LL	LR	LM	S	KB1	KB2	L1	L2	L3
<b>R88M-K7K515C□</b>	312	133	268	42	219	290	117.5	117.5	149
<b>R88M-K7K515C-B□</b>	337	113	293	42	253	315	117.5	152.5	183

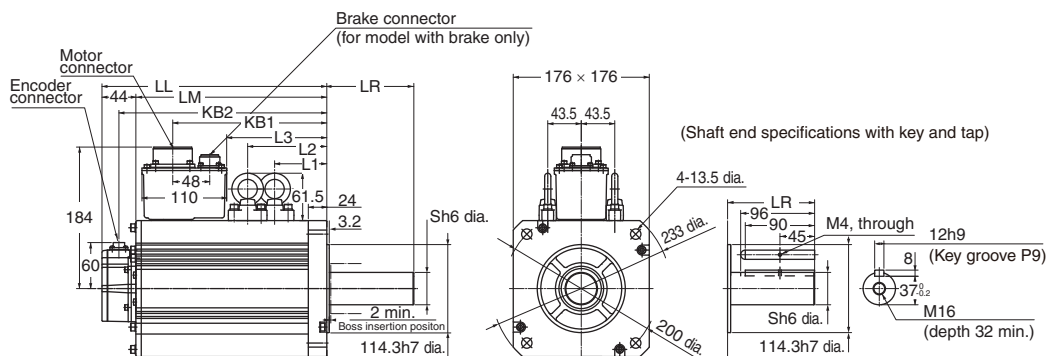

**Note:** The standard models have a straight shaft. A model with a key and tap is indicated by adding "S2" to the end of the model number. Models with an oil seal are indicated with O at the end of the model number. The motor dimensions do not change.

## 11kW/15kW

### • Without brake

- R88M-K11K015C (-S2)/K15K015C (-S2) **ABS**

### • With brake

- R88M-K11K015C-B (S2)/R88M-K15K015C-B (S2) **ABS**

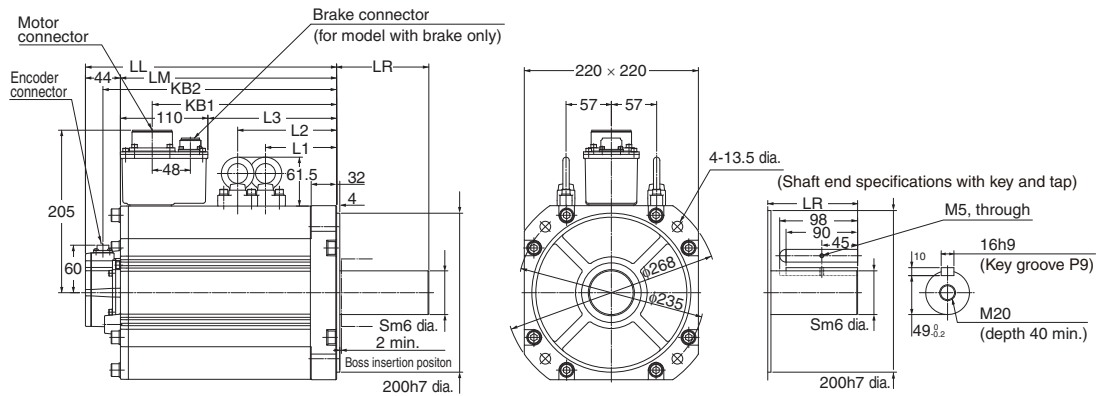

Model	Dimensions (mm)								
	LL	LR	LM	S	KB1	KB2	L1	L2	L3
R88M-K11K015C□	316	116	272	55	232	294	124.5	124.5	162
R88M-K15K015C□	384	116	340	55	300	362	158.5	158.5	230
R88M-K11K015C-B□	364	116	320	55	266	342	124.5	159.5	196
R88M-K15K015C-B□	432	116	388	55	334	410	158.5	193.5	264

**Note:** The standard models have a straight shaft. A model with a key and tap is indicated by adding "S2" to the end of the model number. Models with an oil seal are indicated with O at the end of the model number. The motor dimensions do not change.

# AC Servomotor/Drive G5-series

## 1,000 r/min Servomotors (200 VAC)

900W

• Without brake

- R88M-K90010H (-S2) **INC**
- R88M-K90010T (-S2) **ABS**

• With brake

- R88M-K90010H-B (S2) **INC**
- R88M-K90010T-B (S2) **ABS**

Model	Dimensions (mm)		
	LL	LM	KB2
R88M-K90010□	155.5	111.5	133.5
R88M-K90010□-B□	183.5	139.5	161.5

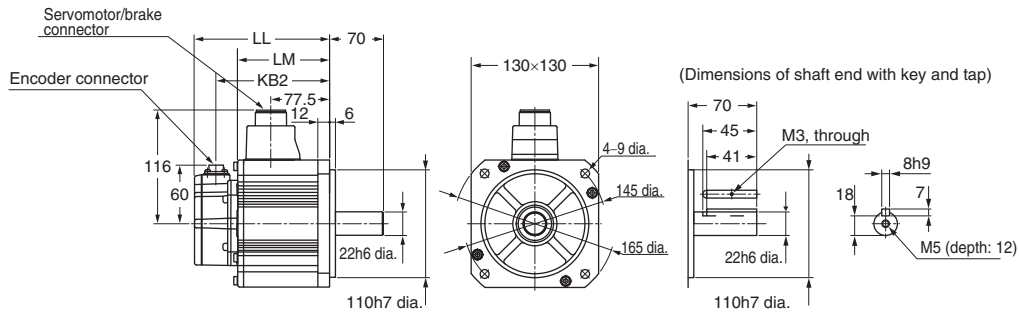

## 2kW/3kW

• Without brake

- R88M-K2K010H (-S2)/-K3K010H (-S2) **INC**
- R88M-K2K010T (-S2)/-K3K010T (-S2) **ABS**

• With brake

- R88M-K2K010H-B (S2)/-K3K010H-B (S2) **INC**
- R88M-K2K010T-B (S2)/-K3K010T-B (S2) **ABS**

Model	Dimensions (mm)			
	LL	LM	KB1	KB2
R88M-K2K010□	163.5	119.5	82.5	141.5
R88M-K3K010□	209.5	165.5	128.5	187.5
R88M-K2K010□-B□	192.5	148.5	82.5	170.5
R88M-K3K010□-B□	238.5	194.5	128.5	216.5

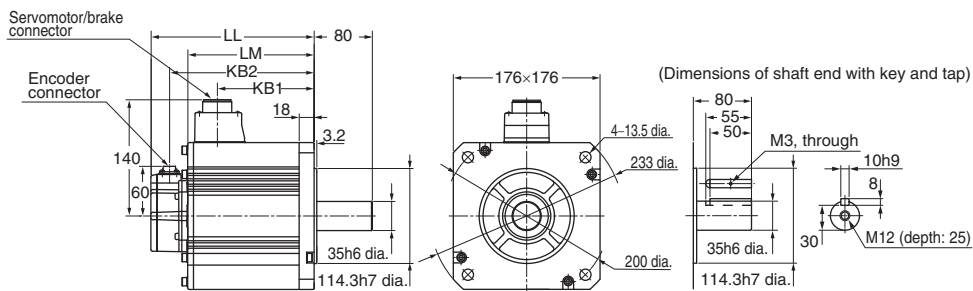

## 4.5kW

• Without brake

- R88M-K4K510T (-S2) **ABS**

• With brake

- R88M-K4K510T-B (S2) **ABS**

Model	Dimensions (mm)							
	LL	LR	LM	S	KB1	KB2	L1	L2
R88M-K4K510T□	266	113	222	42	185	244	98	98
R88M-K4K510T-B□	291	113	247	42	185	269	98	133

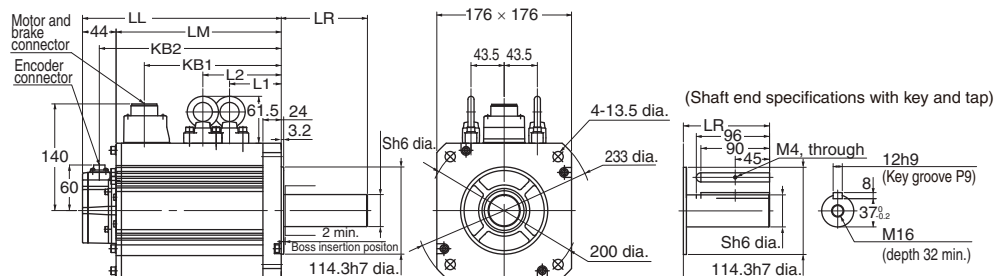

**Note:** The standard models have a straight shaft. A model with a key and tap is indicated by adding "S2" to the end of the model number. Models with an oil seal are indicated with O at the end of the model number. The motor dimensions do not change.

## 6kW

### • Without brake

- R88M-K6K010T (-S2) **ABS**

### • With brake

- R88M-K6K010T-B (S2) **ABS**

Model	Dimensions (mm)								
	LL	LR	LM	S	KB1	KB2	L1	L2	L3
R88M-K6K010T□	312	113	268	42	219	290	117.5	117.5	149
R88M-K6K010T-B□	337	113	293	42	253	315	117.5	152.5	183

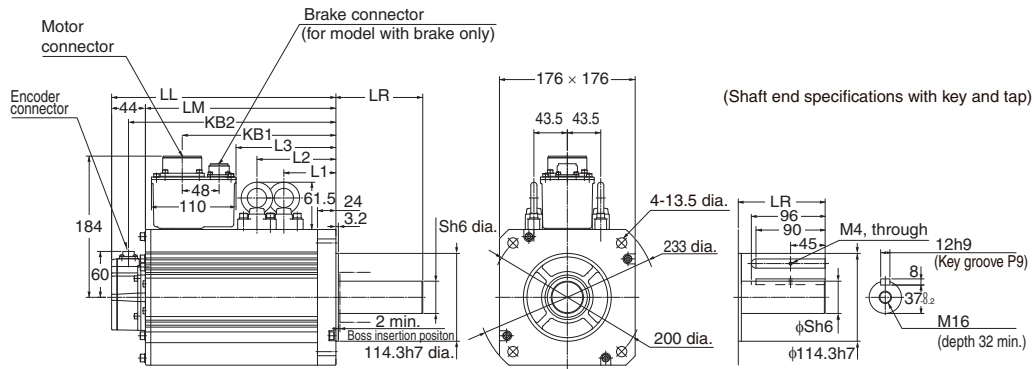

**Note:** The standard models have a straight shaft. A model with a key and tap is indicated by adding "S2" to the end of the model number. Models with an oil seal are indicated with O at the end of the model number. The motor dimensions do not change.

# AC Servomotor/Drive G5-series

## 1,000 r/min Servomotors (400 VAC)

900W

• Without brake

- R88M-K90010F (-S2) **INC**
- R88M-K90010C (-S2) **ABS**

• With brake

- R88M-K90010F-B (S2) **INC**
- R88M-K90010C-B (S2) **ABS**

Model	Dimensions (mm)			
	LL	LM	KB1	KB2
R88M-K90010□	155.5	111.5	77.5	133.5
R88M-K90010□-B□	183.5	139.5	74.5	161.5

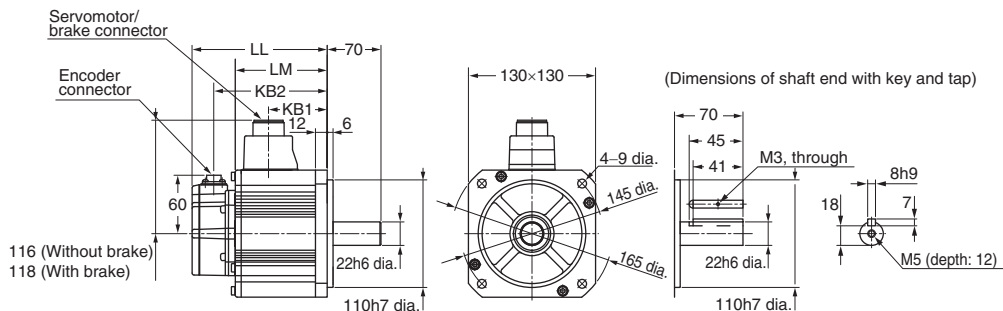

2kW/3kW

• Without brake

- R88M-K2K010F (-S2)/-K3K010F (-S2) **INC**
- R88M-K2K010C (-S2)/-K3K010C (-S2) **ABS**

• With brake

- R88M-K2K010F-B (S2)/-K3K010F-B (S2) **INC**
- R88M-K2K010C-B (S2)/-K3K010C-B (S2) **ABS**

Model	Dimensions (mm)			
	LL	LM	KB1	KB2
R88M-K2K010□	163.5	119.5	82.5	141.5
R88M-K3K010□	209.5	165.5	128.5	187.5
R88M-K2K010□-B□	192.5	148.5	82.5	170.5
R88M-K3K010□-B□	238.5	194.5	128.5	216.5

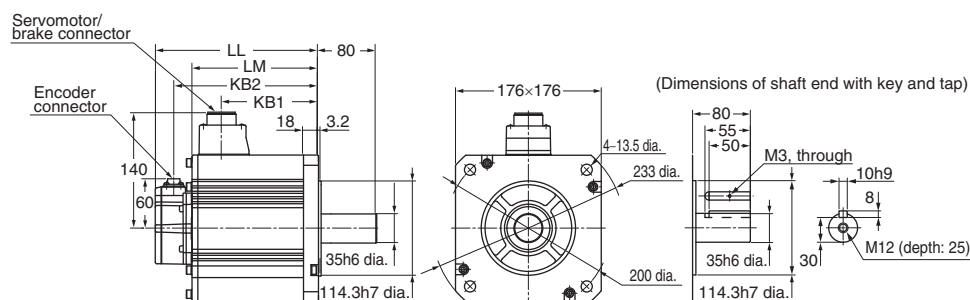

4.5kW

• Without brake

- R88M-K4K510C (-S2) **ABS**

• With brake

- R88M-K4K510C-B (S2) **ABS**

Model	Dimensions (mm)							
	LL	LR	LM	S	KB1	KB2	L1	L2
R88M-K4K510T□	266	113	222	42	185	244	98	98
R88M-K4K510T-B□	291	113	247	42	185	269	98	133

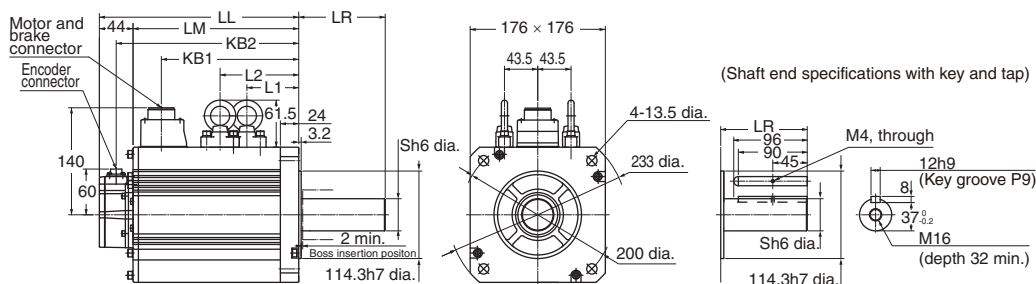

**Note:** The standard models have a straight shaft. A model with a key and tap is indicated by adding "S2" to the end of the model number. Models with an oil seal are indicated with O at the end of the model number. The motor dimensions do not change.

## 6kW

### • Without brake

- R88M-K6K010C (-S2) **ABS**

### • With brake

- R88M-K6K010C-B (S2) **ABS**

Model	Dimensions (mm)								
	LL	LR	LM	S	KB1	KB2	L1	L2	L3
R88M-K6K010C□	312	113	268	42	219	290	117.5	117.5	149
R88M-K6K010C-B□	337	113	293	42	253	315	117.5	152.5	183

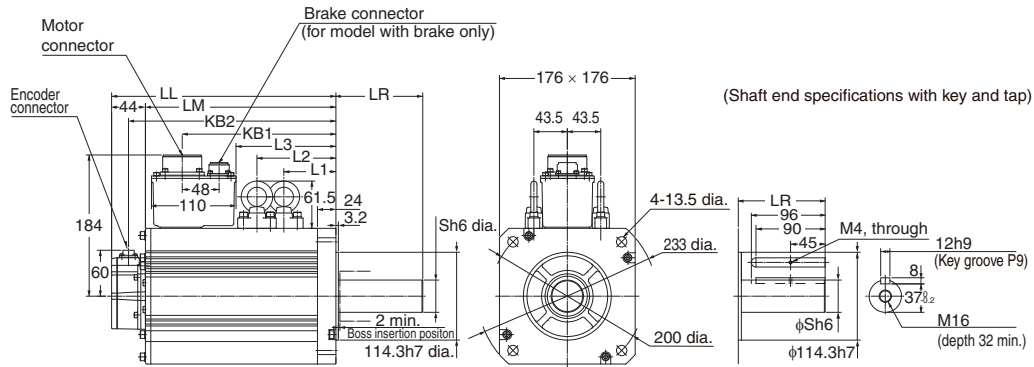

**Note:** The standard models have a straight shaft. A model with a key and tap is indicated by adding "S2" to the end of the model number. Models with an oil seal are indicated with O at the end of the model number. The motor dimensions do not change.

# G5-series Linear Motor

# R88L-EC-□

## Contents

- Ordering Information
- Specifications
  - General Specifications
    - Iron-core Linear Motors
    - Ironless Linear Motors
  - Characteristics
    - Iron-core Linear Motors
    - Ironless Linear Motors
- Dimensions

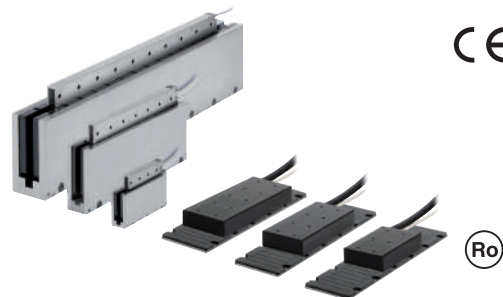

## Ordering Information

Refer to the Ordering Information.

## Specifications

### General Specifications

#### ● Iron-core Linear Motors

Item	Description
Operating ambient temperature humidity	0 to 40°C, 20% to 80% (with no condensation)
Storage ambient temperature and humidity	-20 to +65°C, 85% max. (with no condensation)
Operating and storage atmosphere	No corrosive gases
Vibration resistance*	Acceleration of 49 m/s <sup>2</sup> max. in X, Y, and Z directions
Impact resistance	Acceleration of 98 m/s <sup>2</sup> max. 3 times each in X, Y, and Z directions
Insulation resistance	Between power terminal and FG terminal: 10 MΩ min. (at 500 VDC)
Dielectric strength	Between power terminal and FG terminal: 2,750 VDC for 1 s Between power terminal and sensor: 2,750 VDC for 1 s
Protective structure	IP00
Maximum coil temperature (Motor Coil Unit)	130°C
Maximum magnet temperature (Magnet Track)	70°C
Insulation class	Class B
Cooling method	Self-cooling
International standard	EN60034-1
EC directive	
Low voltage directive	

#### ● Ironless Linear Motors

Item	Description
Operating ambient temperature humidity	0 to 40°C, 20% to 80% (with no condensation)
Storage ambient temperature and humidity	-20 to +65°C, 85% max. (with no condensation)
Operating and storage atmosphere	No corrosive gases
Vibration resistance*	Acceleration of 49 m/s <sup>2</sup> max. in X, Y, and Z directions
Impact resistance	Acceleration of 98 m/s <sup>2</sup> max. 3 times each in X, Y, and Z directions
Insulation resistance	Between power terminal and FG terminal: 10 MΩ min. (at 500 VDC)
Dielectric strength	Between power terminal and FG terminal: 2,250 VDC for 1 s Between power terminal and sensor: 2,250 VDC for 1 s
Protective structure	IP00
Maximum coil temperature (Motor Coil Unit)	110°C
Maximum magnet temperature (Magnet Track)	70°C
Insulation class	Class B
Cooling method	Self-cooling
International standard	EN60034-1
EC directive	
Low voltage directive	

\* The amplitude may be increased by machine resonance. As a guideline, do not exceed 80% of the specified value.

## Characteristics/Speed - Force Characteristics

### Characteristics

#### ● Iron-core Linear Motors

Item	Unit	R88L-EC-						
		FW-0303-ANPC	FW-0306-ANPC	FW-0606-ANPC	FW-0609-ANPC	FW-0612-ANPC	FW-1112-ANPC	FW-1115-ANPC
Maximum speed (100VAC)	m/s	2.5	2.5	2	-	-	-	-
Maximum speed (200VAC)	m/s	5	5	4	4	4	2	2
Maximum speed (400VAC)	m/s	10	10	8	8	8	4	4
Continuous force*1	N	48	96	160	240	320	608	760
Momentary maximum force*2	N	105	210	400	600	800	1,600	2,000
Continuous current*2	Arms	1.24	2.4	3.4	5.2	6.9	6.5	8.2
Momentary maximum current*1	Arms	3.1	6.1	10	15	20	20	25
Motor force constant	N/Arms	39.7	39.7	46.5	46.5	46.5	93.0	93.0
Back electromotive force	V·s/m	13.2	13.2	15.5	15.5	15.5	31	31
Motor constant	N/√W	9.75	13.78	19.49	23.87	27.57	41.47	46.37
Phase resistance	Ω	5.34	2.68	1.83	1.23	0.92	1.6	1.29
Phase inductance	mH	34.7	17.4	13.7	9.2	6.9	12.8	10.3
Electrical time constant	ms	6.5	6.5	7.5	7.5	7.5	8	8
Maximum continuous power consumption	W	32	63	88	131	175	279	349
Thermal resistance	K/W	2.20	1.10	0.78	0.52	0.39	0.23	0.18
Thermal time constant	s	110	110	124	124	124	126	126
Magnetic attractive force	N	300	500	1,020	1,420	1,820	3,640	4,440
Magnetic pole pitch	mm	24	24	24	24	24	24	24
Mass (except cables)	kg	0.48	0.78	1.31	1.84	2.37	4.45	5.45
Cooling plate dimensions	mm	238×220×10	238×220×10	250×287×12	250×287×12	250×287×12	371×330×14	371×330×14
Application Servo Drives (R88D-□-ECT-L)		KN01L/KN02H/ KN06F	KN02L/KN04H/ KN10F	KN04L/KN08H/ KN15F	KN10H/KN20F	KN15H/KN30F	KN15H/KN30F	KN15H/KN30F
Magnet Trac (R88L-EC-)		FM-03096-A/FM-03144-A/ FM-03384-A		FM-06192-A/FM-06288-A			FM-11192-A/FM-11288-A	
Magnet Trac Unit Length	mm	96/144/384		192/288			192/288	

\*1. This shows a value measured when the Motor Coil Unit is at 100°C and the Magnet Trac is at 25°C. The coil unit is mounted in the center of an aluminum moving table (heat sink) which has its size larger than indicated in table as cooling condition.

\*2. The Motor Coil Unit is subjected to a temperature rise of 6 K/s.

# AC Servomotor/Drive G5-series

## Speed - Force Characteristics

The following graphs show the performance when the coil temperature of the Motor Coil Unit is 100°C.

The maximum operation speed is limited by considering the guide mechanism, encoder, and other aspects. If it is 5 m/s or higher, please consult with your OMRON representative.

R88L-EC-FW-0303

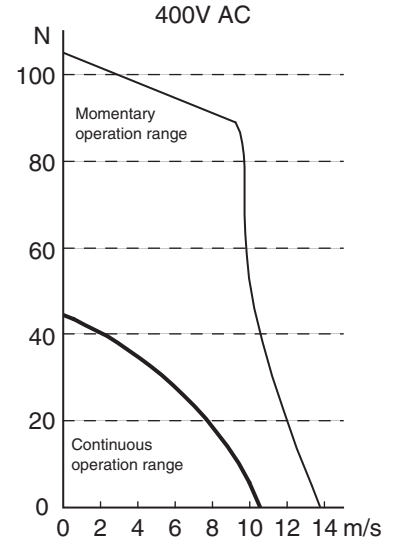
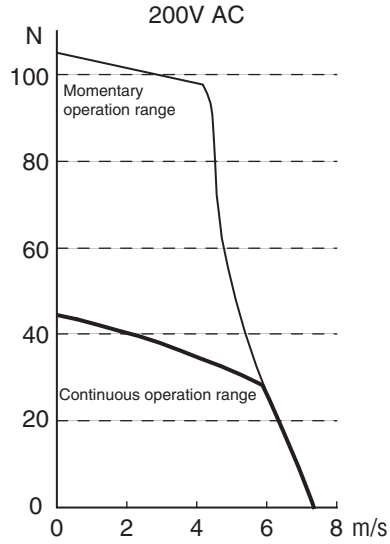
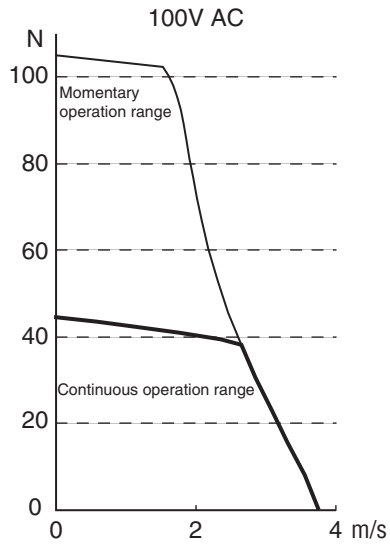

R88L-EC-FW-0306

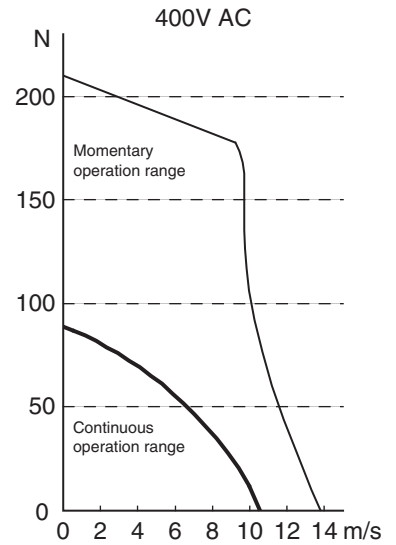
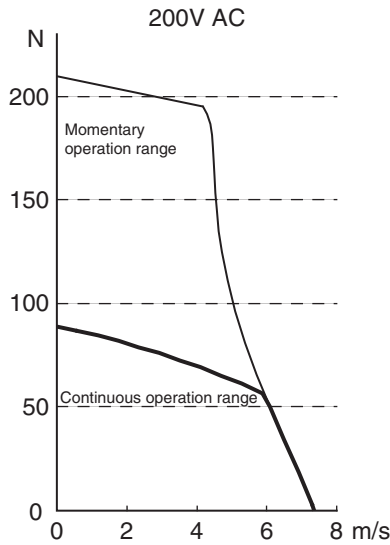
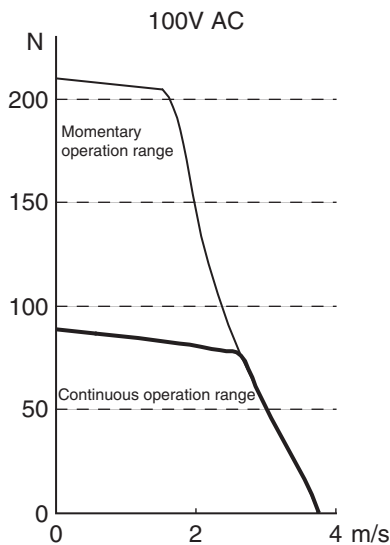

R88L-EC-FW-0606

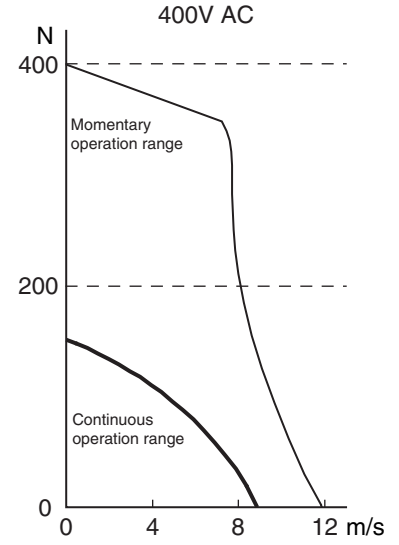
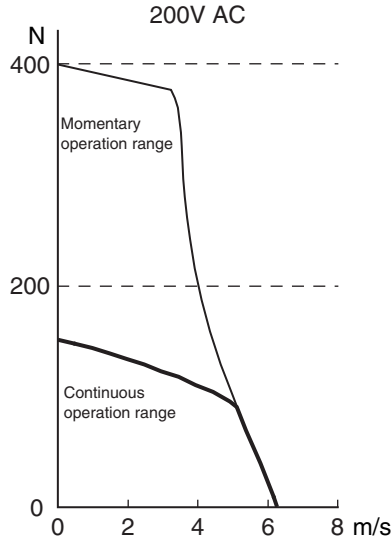
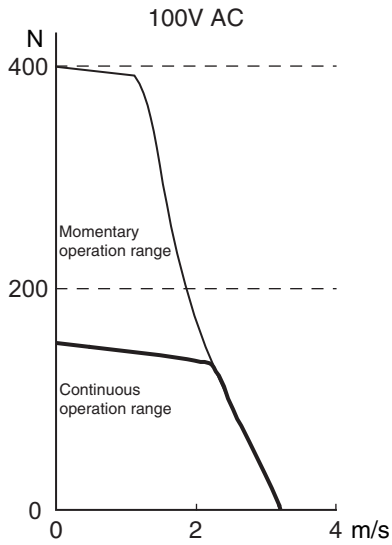

R88L-EC-FW-0609

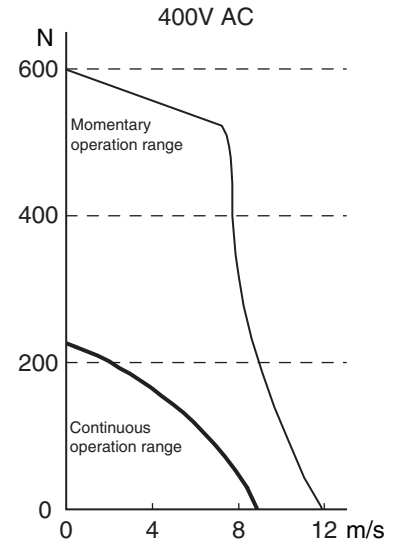
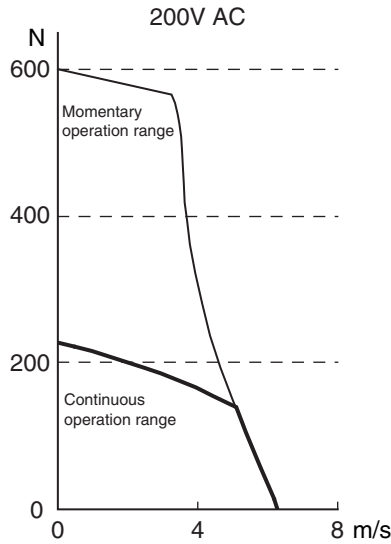
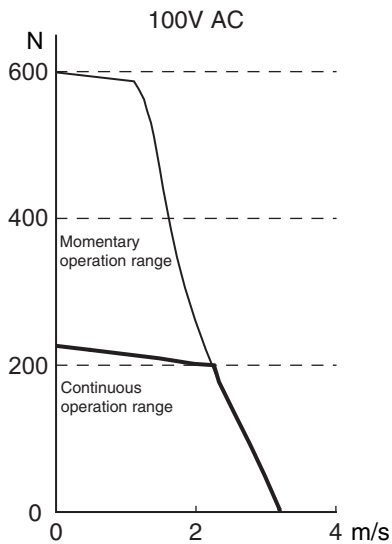

R88L-EC-FW-0612

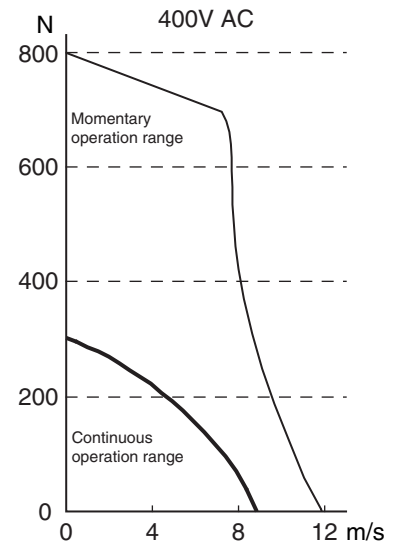
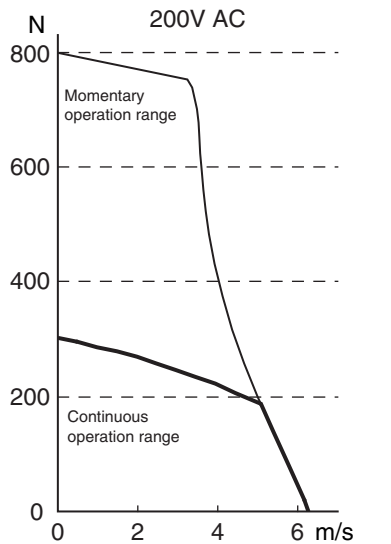
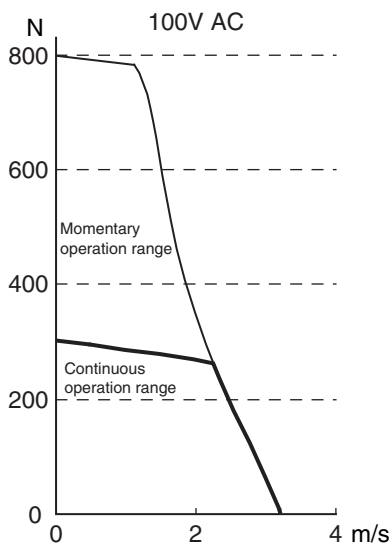

G5-Series  
System Configuration

EtherCAT Communications  
AC Servo Drive

EtherCAT Communications  
Linear Motor Type  
AC Servo Drive

General-purpose Inputs  
AC Servo Drive

ML-II Type  
AC Servo Drive

AC Servomotors

Linear Motor

Decelerator

R88L-EC-FW-1112

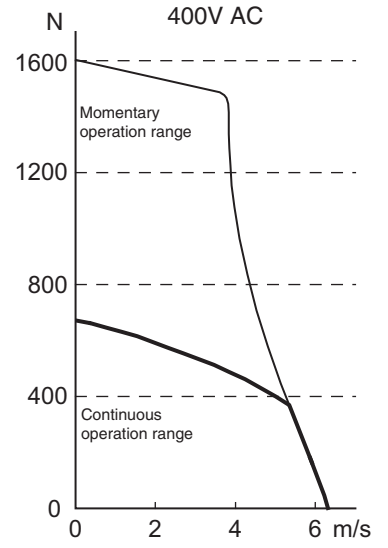
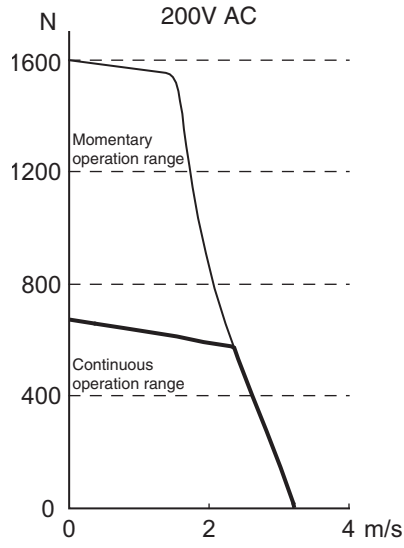
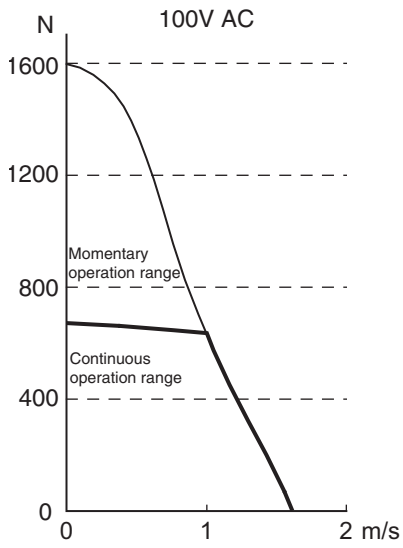

R88L-EC-FW-1115

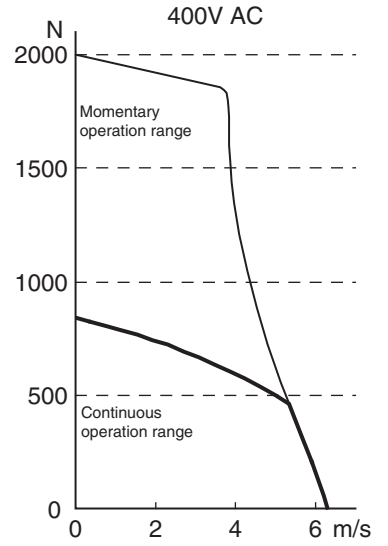
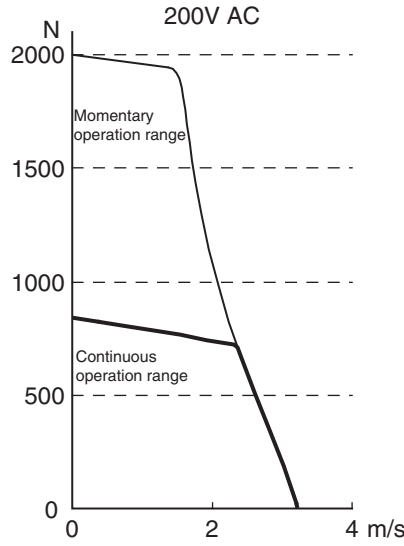
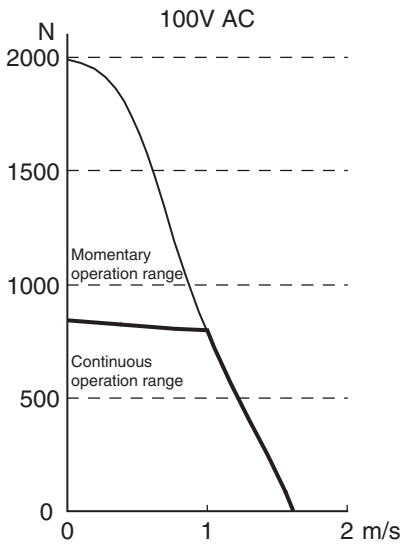

● Ironless Linear Motors

Item	Unit	R88L-EC-									
		GW-0303 -ANPS		GW-0306 -ANPS	GW-0309 -ANPS	GW-0503 -ANPS	GW-0506 -ANPS	GW-0509 -ANPS	GW-0703 -ANPS	GW-0706 -ANPS	GW-0709 -ANPS
Maximum speed (100VAC)	m/s	8	-	8	-	2.2	2.2	2.2	1.2	1.2	-
Maximum speed (200VAC)	m/s	-	16	16	16	4.4	4.4	4.4	2.4	2.4	2.4
Continuous force*1	N	26.5		53	80	58	117	175	117	232	348
Momentary maximum force*2	N	100	96	200	300	240	480	720	552	1110	1730
Continuous current*2	Arms	1.33		2.66	4.0	0.87	1.76	2.60	0.94	1.87	2.81
Momentary maximum current*1	Arms	5.0	4.8	10.0	15.0	3.50	7.1	10.6	4.5	9.0	14
Motor force constant	N/Arms	19.9		19.9	19.9	68.0	68.0	68.0	124.0	124.0	124.0
Back electromotive force	V·s/m	6.6		6.6	6.6	22.7	22.7	22.7	41.3	41.3	41.3
Motor constant	N/√W	4.90		6.93	8.43	9.85	13.96	17.03	17.97	25.44	31.14
Phase resistance	Ω	5.5		2.8	1.8	15.9	8.0	5.3	15.8	7.9	5.3
Phase inductance	mH	1.8		0.9	0.6	13	6.5	4.2	28.0	14.0	9.0
Electrical time constant	ms	0.35		0.35	0.35	0.8	0.8	0.8	1.8	1.8	1.8
Maximum continuous power consumption	W	47		95	142	67	134	200	82	165	247
Thermal resistance	K/W	2.1		1.06	0.71	1.70	0.85	0.65	1.56	1.04	0.52
Thermal time constant	s	36		36	36	72	72	72	96	96	96
Magnetic attractive force	N	0		0	0	0	0	0	0	0	0
Magnetic pole pitch	mm	30		30	30	42	42	42	57	57	57
Mass (except cables)	kg	0.084		0.162	0.24	0.25	0.47	0.69	0.55	0.95	1.35
Application Servo Drives (R88D-□-ECT-L)		KN01L	KN02H	KN04L/ KN08H	KN10H	KN01L/ KN01H	KN02L/ KN04H	KN04L/ KN08H	KN02L/ KN04H	KN04L/ KN08H	KN10H
Magnet Trac (R88L-EC-)		GM-03090-A/GM-03120-A/ GM-03390-A				GM-05126-A/GM-05168-A/ GM-05210-A/GM-05546-A			GM-07114-A/GM-07171-A/ GM-07456-A		
Magnet Trac Unit Length	mm	90/120/390				126/168/210/546			114/171/456		

\*1. This shows a value measured when the Motor Coil Unit is at 100°C and the Magnet Trac is at 25°C.

\*2. The Motor Coil Unit is subjected to a temperature rise of 40 K/s.

G5-Series  
System Configuration

EtherCAT Communications  
AC Servo Drive

EtherCAT Communications  
Linear Motor Type  
AC Servo Drive

General-purpose Inputs  
AC Servo Drive

ML-II Type  
AC Servo Drive

AC Servomotors

Linear Motor

Decelerator

# AC Servomotor/Drive G5-series

## Speed - Force Characteristics

The maximum operation speed is limited by considering the guide mechanism, encoder, and other aspects. If it is 5 m/s or higher, please consult with your OMRON representative.

R88L-EC-GW-0303

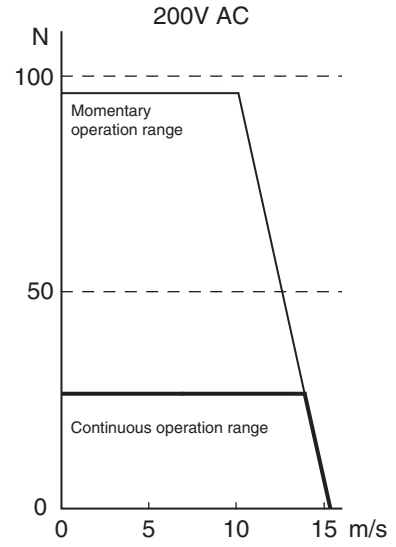
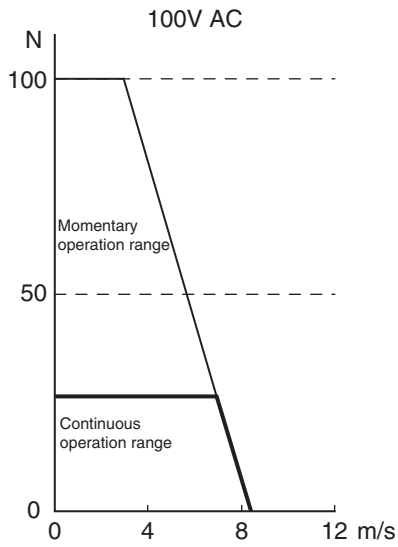

R88L-EC-GW-0306

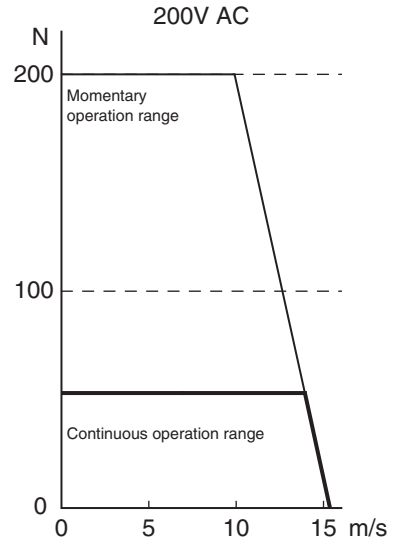
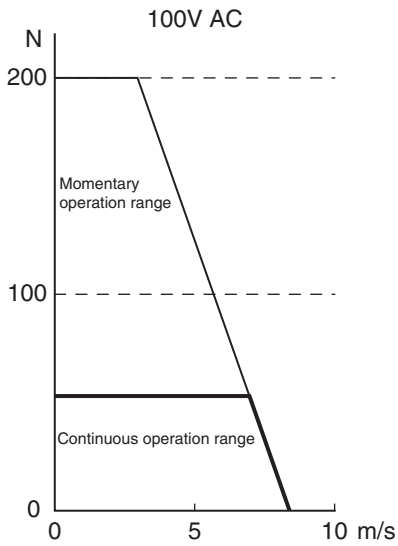

R88L-EC-GW-0309

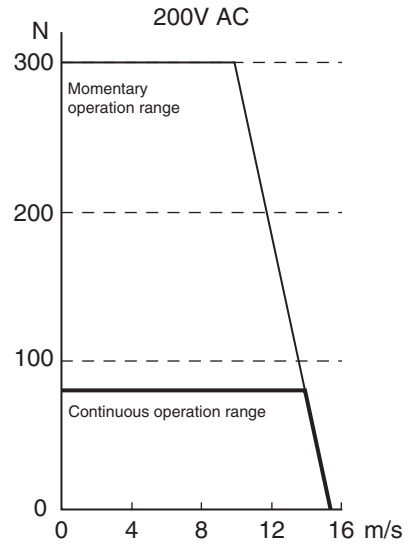
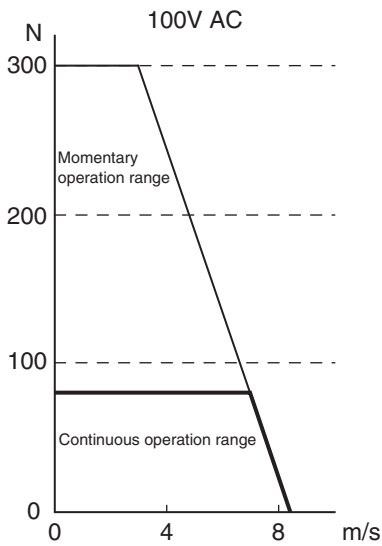

R88L-EC-GW-0503

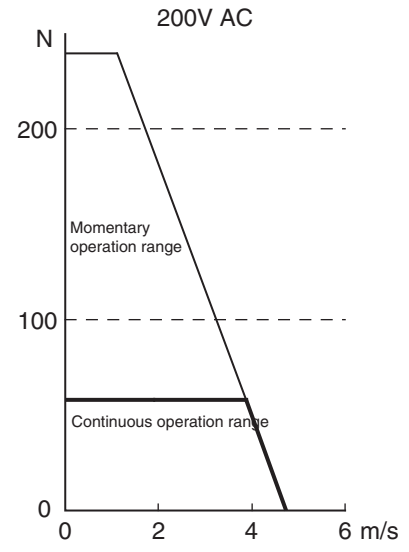
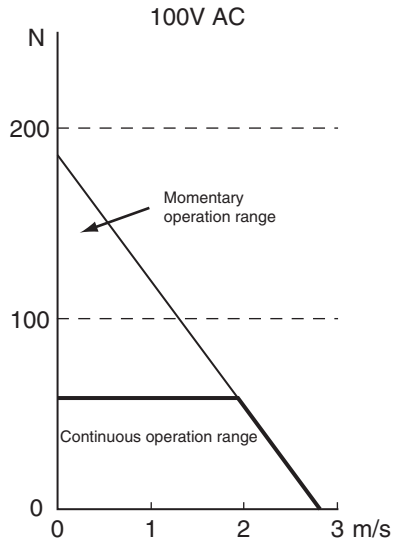

R88L-EC-GW-0506

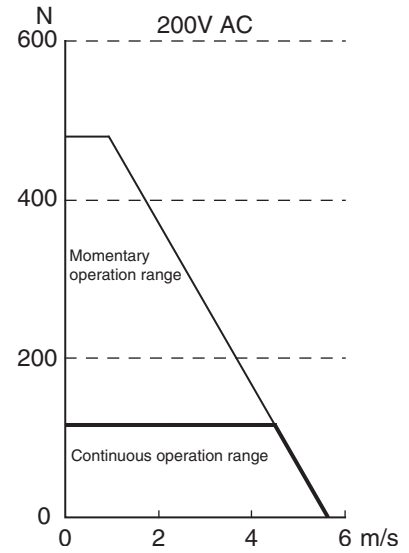
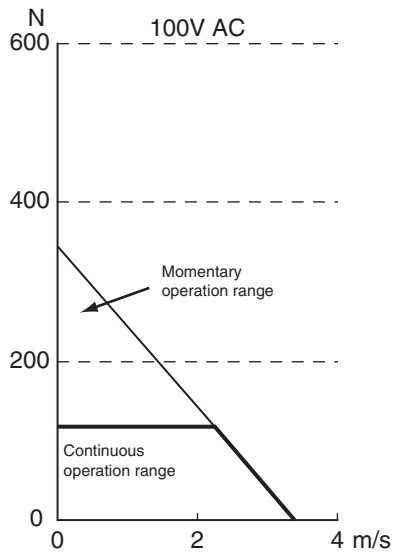

R88L-EC-GW-0509

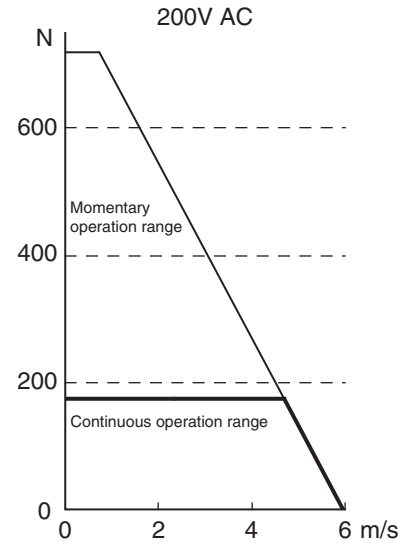
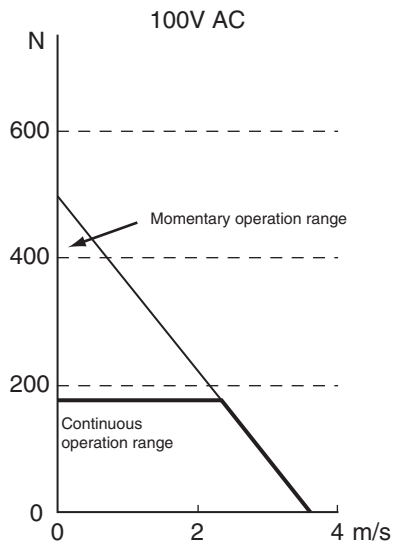

G5-Series  
System Configuration

EtherCAT Communications  
AC Servo Drive

EtherCAT Communications  
Linear Motor Type  
AC Servo Drive

General-purpose Inputs  
AC Servo Drive

ML-II Type  
AC Servo Drive

AC Servomotors

Linear Motor

Decelerator

R88L-EC-GW-0703

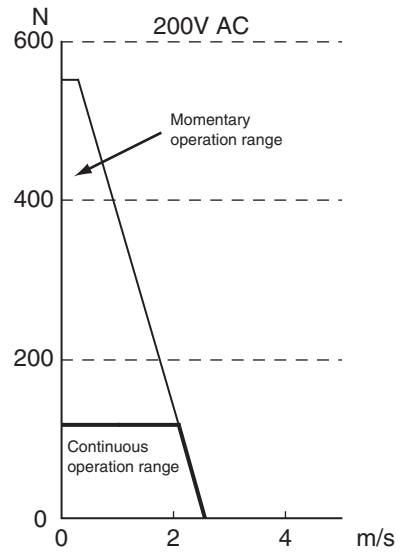
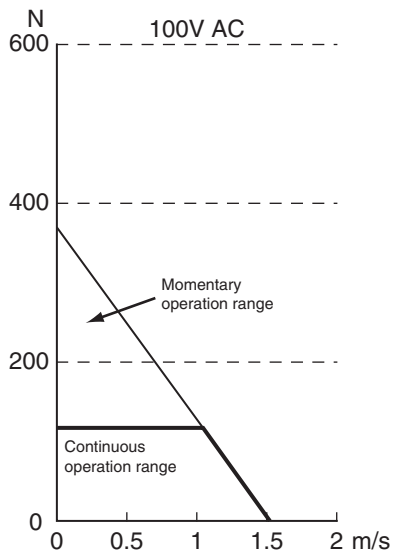

R88L-EC-GW-0706

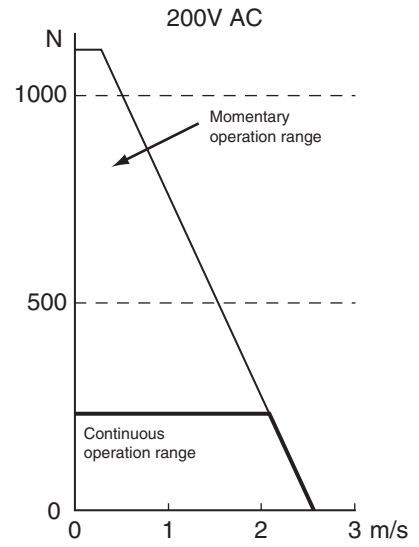
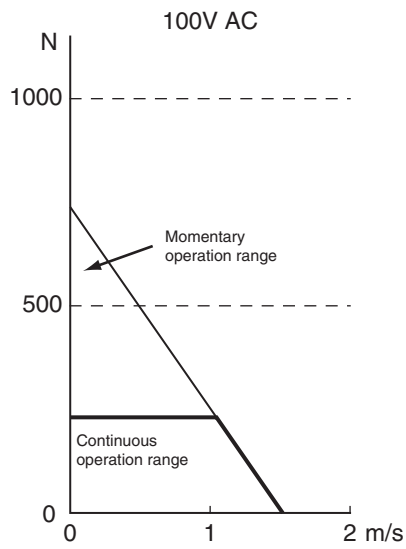

R88L-EC-GW-0709

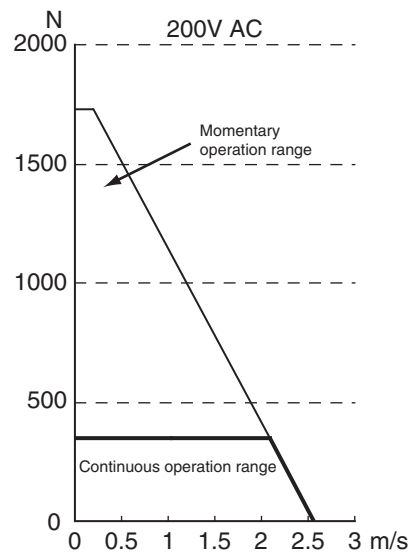
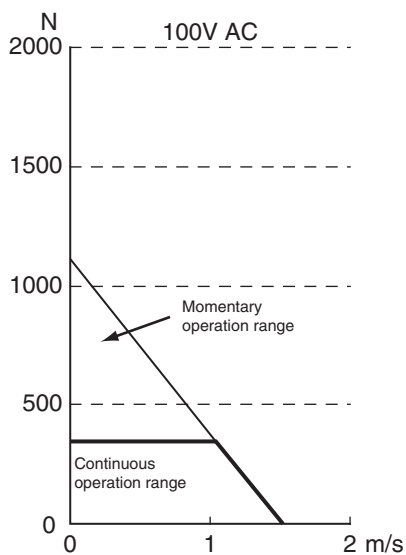



# AC Servomotor/Drive G5-series

## • Motor Coil Unit

- R88L-EC-FW-0606/-0609/-0612

Model	L1 [mm]	Number of holes [N]	Mass [kg] *1
R88L-EC-FW-0606	127 +0.15/-0.35	6	1.59
R88L-EC-FW-0609	175 +0.15/-0.35	8	2.15
R88L-EC-FW-0612	223 +0.15/-0.35	10	2.7

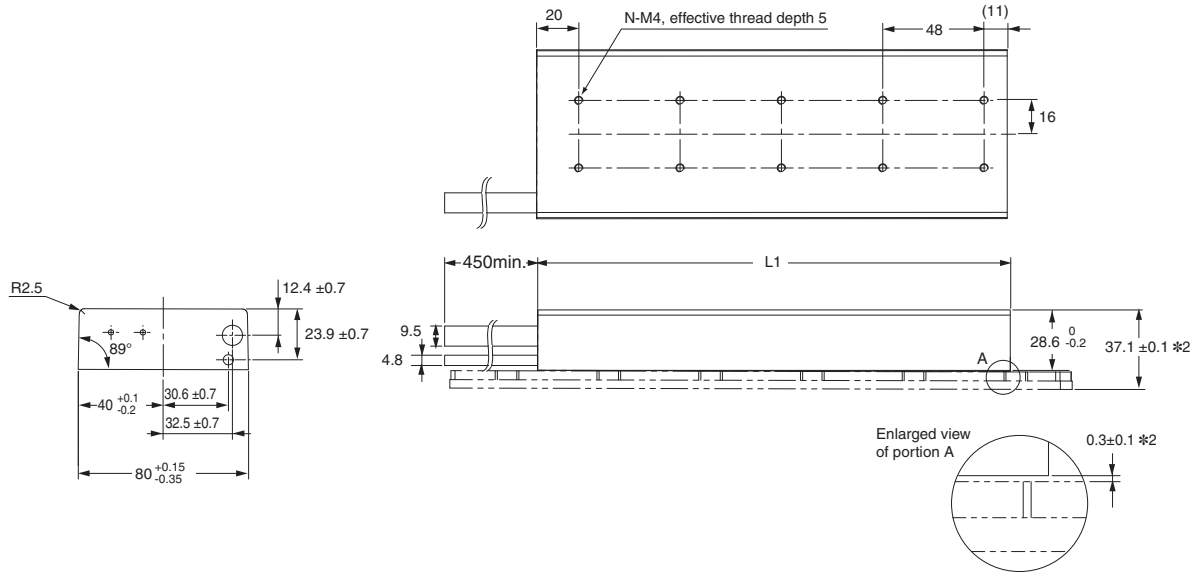

- \*1. The weight of 450-mm cables is included.
- \*2. These values indicate mounting dimensions.

## • Magnet Trac

Model	L2 [mm]	L3 [mm]	Number of holes [N]	Mass [kg]
R88L-EC-FM-06192-A	192	144	8	Approx. 0.77
R88L-EC-FM-06288-A	288	240	12	Approx. 1.15

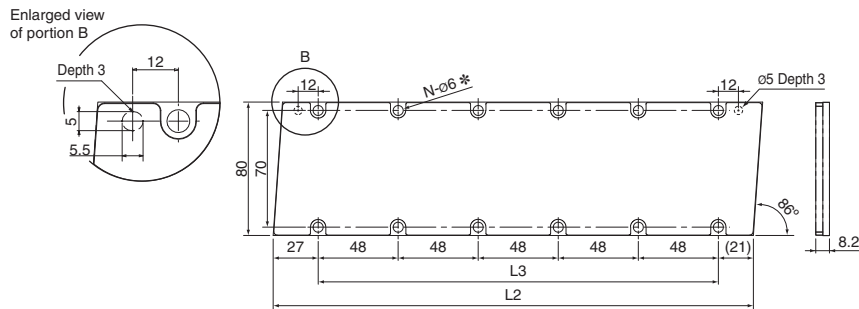

- \* Use M5 low head allen head bolts.

## • Motor Coil Unit

- R88L-EC-FW-1112/-1115

Model	L1 [mm]	Number of holes [N]	Mass [kg] *1
R88L-EC-FW-1112	223 +0.15/-0.35	15	4.89
R88L-EC-FW-1115	271 +0.15/-0.35	18	5.94

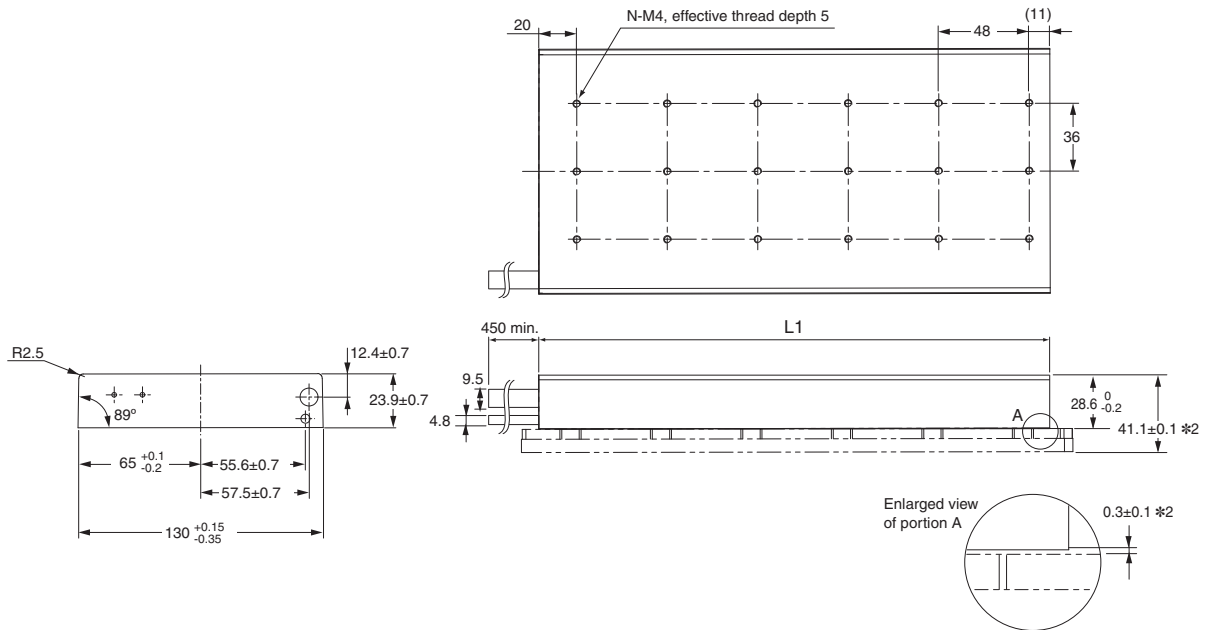

- \*1. The weight of 450-mm cables is included.
- \*2. These values indicate mounting dimensions.

## • Magnet Trac

Model	L2 [mm]	L3 [mm]	Number of holes [N]	Mass [kg]
R88L-EC-FM-11192-A	192	144	8	Approx. 2.12
R88L-EC-FM-11288-A	288	240	12	Approx. 3.18

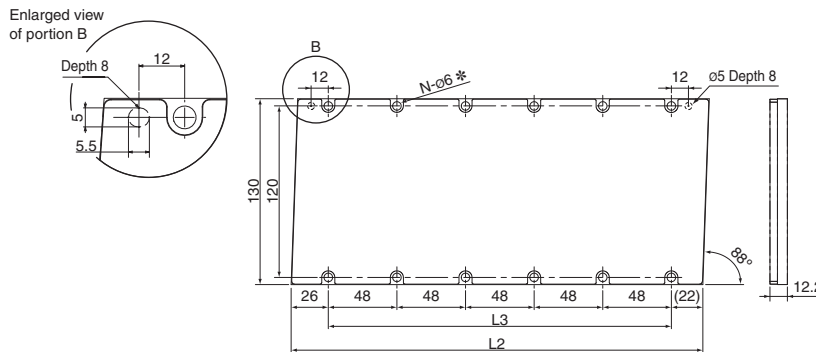

- \* Use M5 low head allen head bolts.

# AC Servomotor/Drive G5-series

## ● Ironless Linear Motors

### • Motor Coil Unit

- R88L-EC-GW-0303/-0306/-0309

Model	L1 [mm]	L2 [mm]	Number of holes [N]	Mass [kg] *
R88L-EC-GW-0303	78	60	4	0.2
R88L-EC-GW-0306	138	120	7	0.28
R88L-EC-GW-0309	198	180	10	0.36

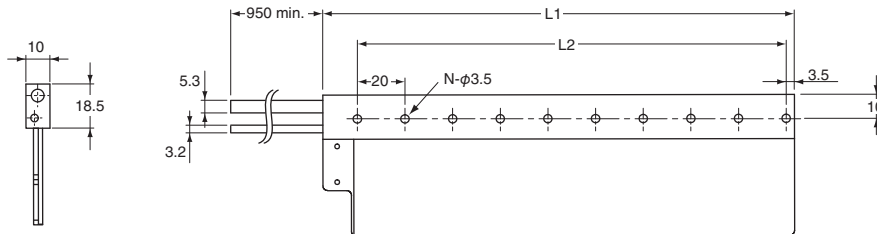

\* The weight of 950-mm cables is included.

### • Magnet Trac

Model	L3 [mm]	L4 [mm]	Number of holes [N]	Mass [kg]
R88L-EC-GM-03090-A	90	60	3	Approx. 0.46
R88L-EC-GM-03120-A	120	90	4	Approx. 0.61
R88L-EC-GM-03390-A	390	360	13	Approx. 1.97

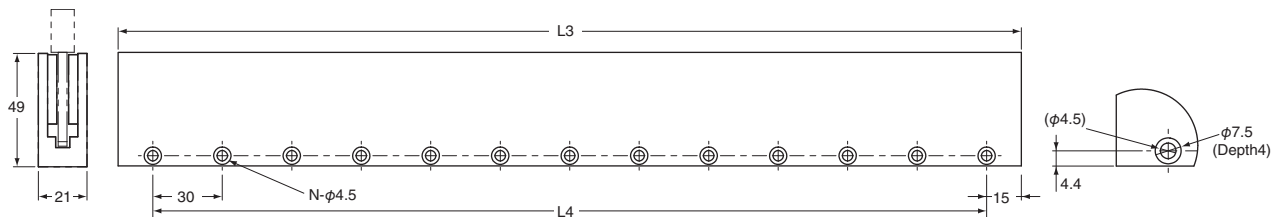

### • Combination diagram

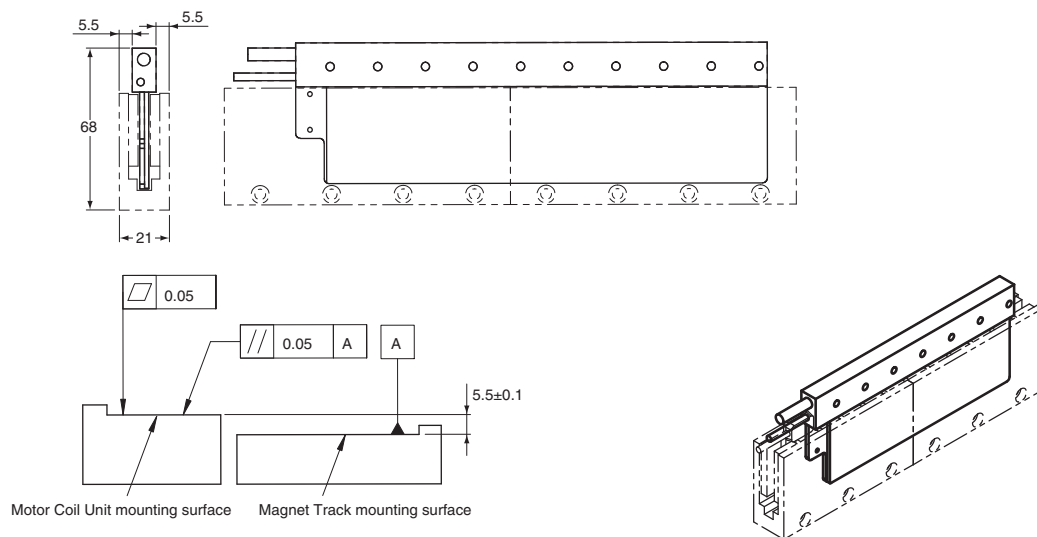

## • Motor Coil Unit

- R88L-EC-GW-0503/-0506/-0509

Model	L1 [mm]	L2 [mm]	Number of holes [N]	Mass [kg] *
R88L-EC-GW-0503	106	84	4	0.48
R88L-EC-GW-0506	190	168	7	0.71
R88L-EC-GW-0509	274	252	10	0.94

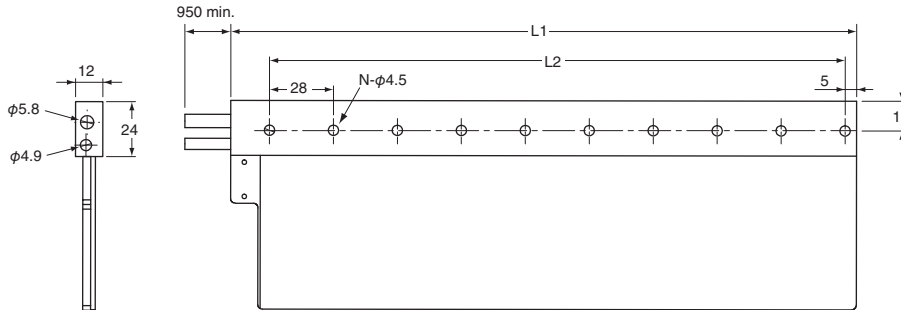

\* The weight of 950-mm cables is included.

## • Magnet Trac

Model	L3 [mm]	L4 [mm]	Number of holes [N]	Mass [kg]
R88L-EC-GM-05126-A	126	84	3	Approx. 1.49
R88L-EC-GM-05168-A	168	126	4	Approx. 1.98
R88L-EC-GM-05210-A	210	168	5	Approx. 2.47
R88L-EC-GM-05546-A	546	504	13	Approx. 6.43

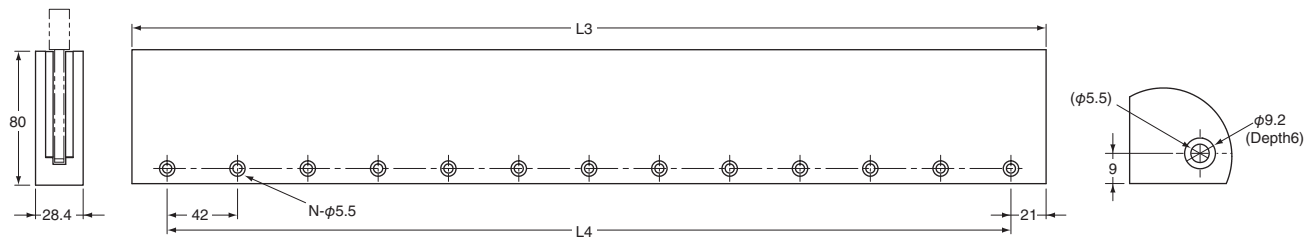

## • Combination diagram

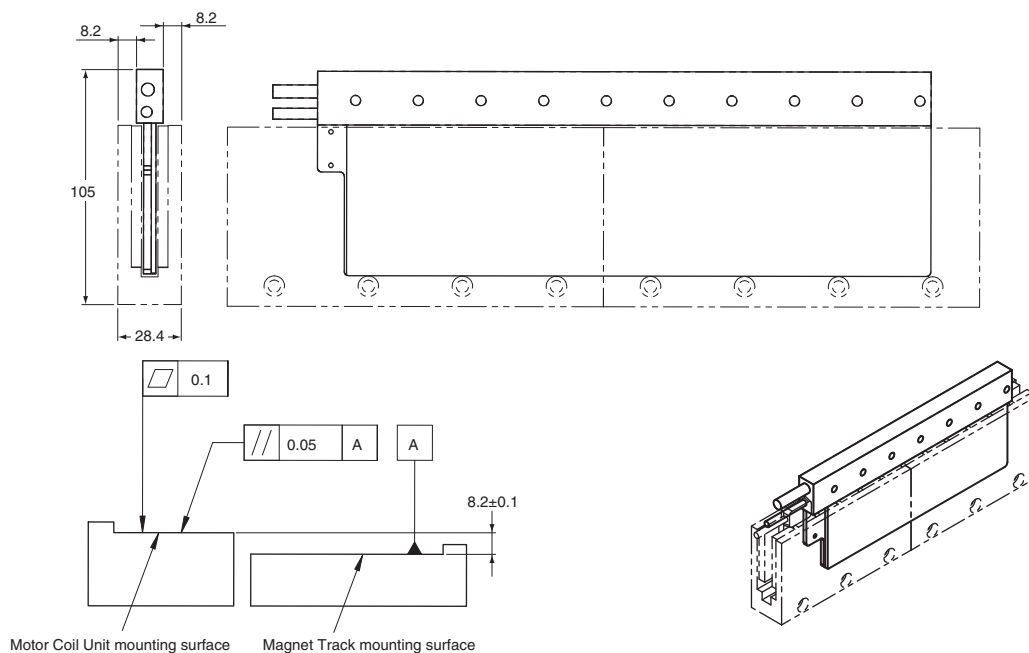

# AC Servomotor/Drive G5-series

## • Motor Coil Unit

• R88L-EC-GW-0703/-0706/-0709

Model	L1 [mm]	L2 [mm]	Number of holes [N]	Mass [kg] *
R88L-EC-GW-0703	134	114	4	0.9
R88L-EC-GW-0706	248	228	7	1.32
R88L-EC-GW-0709	362	342	10	1.74

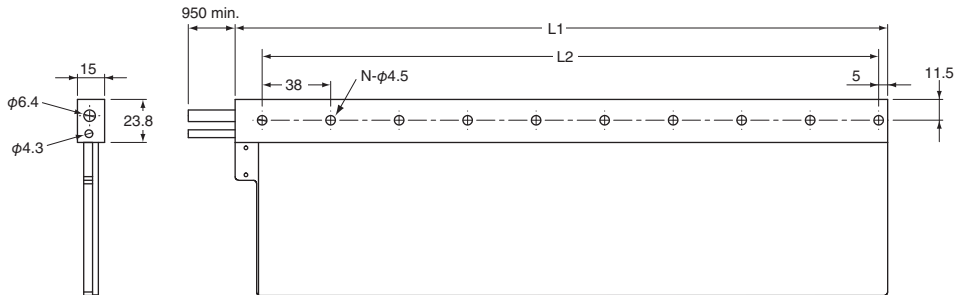

\* The weight of 950-mm cables is included.

## • Magnet Trac

Model	L3 [mm]	L4 [mm]	Number of holes [N]	Mass [kg]
R88L-EC-GM-07114-A	114	57	2	Approx. 2.88
R88L-EC-GM-07171-A	171	114	3	Approx. 4.31
R88L-EC-GM-07456-A	456	399	8	Approx. 11.5

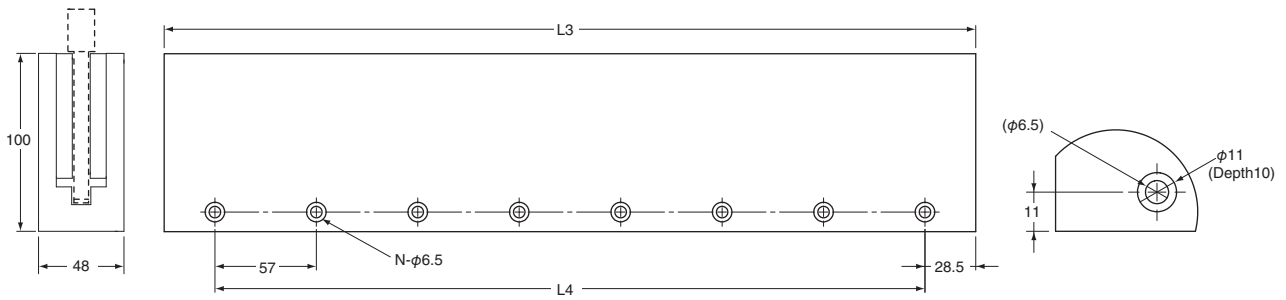

## • Combination diagram

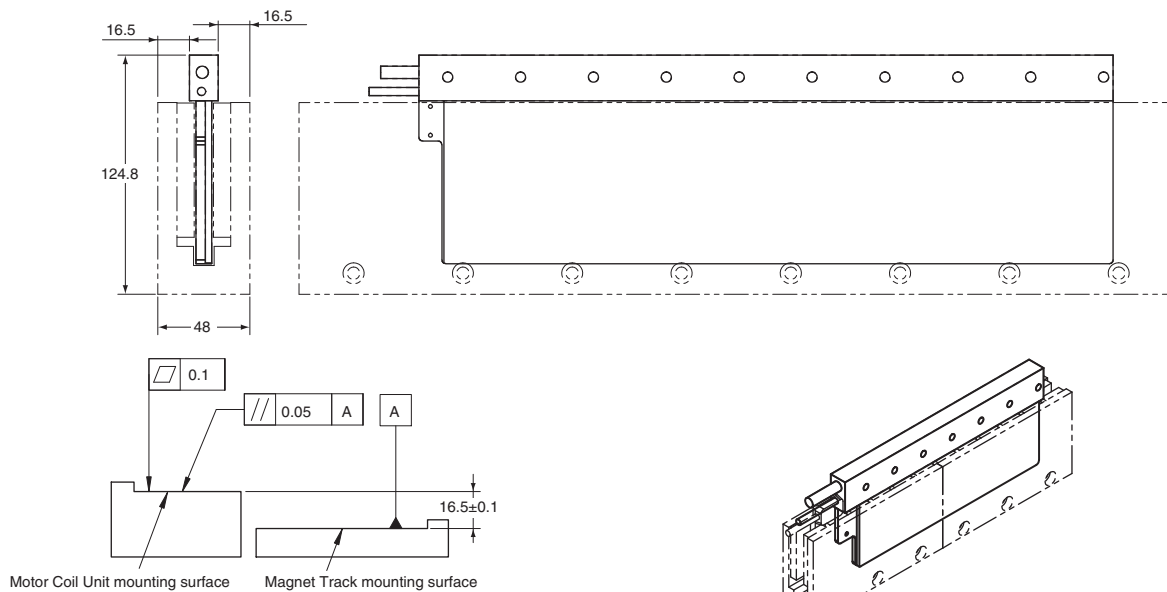

# R88G-HPG/VRXF

## Contents

- Specifications

Backlash: 3 Arcminutes Max.

- For 3,000-r/min Servomotors (50 to 200 W, 400 W, 750 W(AC 200 / 400 V), 1 to 5 kW)
- For 2,000-r/min Servomotors (400 to 600 W, 1 to 5 kW)
- For 1,000-r/min Servomotors (900 W to 3 kW)

Backlash: 15 Arcminutes Max.

- For 3,000-r/min Servomotors (50 to 750 W)

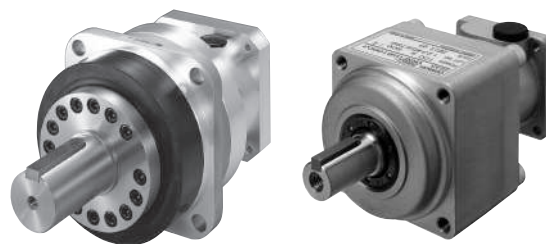

## Specifications

**Backlash: 3 Arcminutes Max.**

● For 3,000-r/min Servomotors (50 to 200 W)

Model			Rated rotation speed	Rated torque	Efficiency	Momentary maximum rotation speed	Momentary maximum torque	Reduction gear inertia	Allowable radial load	Allowable thrust load	Weight
			r/min	N·m	%	r/min	N·m	kg·m <sup>2</sup>	N	N	kg
50 W	1/5	R88G-HPG11B05100B□	600	0.50	63	1200	1.51	5.00×10 <sup>-7</sup>	135	538	0.3
	1/9	R88G-HPG11B09050B□	333	1.12	78	666	3.37	3.00×10 <sup>-7</sup>	161	642	0.3
	1/21	R88G-HPG14A21100B□	143	2.18	65	286	6.55	5.00×10 <sup>-6</sup>	340	1358	1.0
	1/33	R88G-HPG14A33050B□	91	3.75	71	182	11.2	4.40×10 <sup>-6</sup>	389	1555	1.0
	1/45	R88G-HPG14A45050B□	67	5.11	71	134	15.3	4.40×10 <sup>-6</sup>	427	1707	1.0
100 W	1/5	R88G-HPG11B05100B□	600	1.28	80	1200	3.80	5.00×10 <sup>-7</sup>	135	538	0.3
	1/11	R88G-HPG14A11100B□	273	2.64	75	546	7.84	6.00×10 <sup>-6</sup>	280	1119	1.0
	1/21	R88G-HPG14A21100B□	143	5.38	80	286	16.0	5.00×10 <sup>-6</sup>	340	1358	1.0
	1/33	R88G-HPG20A33100B□	91	6.86	65	182	20.4	6.50×10 <sup>-6</sup>	916	3226	2.4
	1/45	R88G-HPG20A45100B□	67	9.36	65	134	27.8	6.50×10 <sup>-6</sup>	1006	3541	2.4
200 W	1/5	R88G-HPG14A05200B□	600	2.50	78	1200	7.45	2.07×10 <sup>-5</sup>	221	883	1.0
	1/11	R88G-HPG14A11200B□	273	5.98	85	546	17.9	1.93×10 <sup>-5</sup>	280	1119	1.1
	1/21	R88G-HPG20A21200B□	143	10.2	76	286	30.5	4.90×10 <sup>-5</sup>	800	2817	2.9
	1/33	R88G-HPG20A33200B□	91	17.1	81	182	51.1	4.50×10 <sup>-5</sup>	916	3226	2.9
	1/45	R88G-HPG20A45200B□	67	23.3	81	134	69.6	4.50×10 <sup>-5</sup>	1006	3541	2.9

- Note:**
1. The value given for the reduction gear inertia is the Servomotor shaft conversion value.
  2. The protection structure of the Servomotor with the reduction gear meets the requirements of IP44.
  3. The value given for the allowable radial load is the value at the center of the shaft (T/2).
  4. The standard shaft type is a straight shaft. A model with a key and tap is indicated by adding "J" to the end of the model number (the suffix shown in the box).

# AC Servomotor/Drive G5-series

## ● For 3,000-r/min Servomotors (400 W, 750 W (AC 200 / 400 V), 1 to 5 kW)

Model		Rated rotation speed	Rated torque	Efficiency	Momentary maximum rotation speed	Momentary maximum torque	Reduction gear inertia	Allowable radial load	Allowable thrust load	Weight	
		r/min	N•m	%	r/min	N•m	kg•m <sup>2</sup>	N	N	kg	
400 W	1/5	R88G-HPG14A05400B□	600	5.66	87	1200	16.5	2.07×10 <sup>-5</sup>	221	883	1.1
	1/11	R88G-HPG20A11400B□	273	11.7	82	546	34.3	5.67×10 <sup>-5</sup>	659	2320	2.9
	1/21	R88G-HPG20A21400B□	143	23.5	86	286	68.6	4.90×10 <sup>-5</sup>	800	2547	2.9
	1/33	R88G-HPG32A33400B□	91	34.7	81	182	101.6	6.20×10 <sup>-5</sup>	1565	6240	7.5
	1/45	R88G-HPG32A45400B□	67	47.4	81	134	138.5	6.10×10 <sup>-5</sup>	1718	6848	7.5
750 W (200 V)	1/5	R88G-HPG20A05750B□	600	9.96	83	1000	29.5	6.80×10 <sup>-5</sup>	520	1832	2.9
	1/11	R88G-HPG20A11750B□	273	20.0*1	88	455	68.7	6.00×10 <sup>-5</sup>	659	2320	3.1
	1/21	R88G-HPG32A21750B□	143	42.3	84	238	125.2	3.00×10 <sup>-4</sup>	1367	5448	7.8
	1/33	R88G-HPG32A33750B□	91	69.7	88	152	206.2	2.70×10 <sup>-4</sup>	1565	6240	7.8
	1/45	R88G-HPG32A45750B□	67	95.0	88	112	281.2	2.70×10 <sup>-4</sup>	1718	6848	7.8
750 W (400 V)	1/5	R88G-HPG32A052K0B□	600	7.65	64	1000	22.9	3.90×10 <sup>-4</sup>	889	3542	7.4
	1/11	R88G-HPG32A112K0B□	273	20.5	78	455	61.4	3.40×10 <sup>-4</sup>	1126	4488	7.9
	1/21	R88G-HPG32A211K5B□	143	42.2	84	238	126.3	3.00×10 <sup>-4</sup>	1367	5448	7.9
	1/33	R88G-HPG32A33600SB□	91	69.4	88	152	207.9	2.80×10 <sup>-4</sup>	1565	6240	7.9
	1/45	R88G-HPG50A451K5B□	67	90.3	84	112	270.6	4.70×10 <sup>-4</sup>	4538	15694	19.0
1 kW	1/5	R88G-HPG32A052K0B□	600	11.4	72	1000	34.4	3.90×10 <sup>-4</sup>	889	3542	7.4
	1/11	R88G-HPG32A112K0B□	273	29.0	83	454	87.2	3.40×10 <sup>-4</sup>	1126	4488	7.9
	1/21	R88G-HPG32A211K5B□	143	58.1	87	238	174.5	3.00×10 <sup>-4</sup>	1367	5448	7.9
	1/33	R88G-HPG50A332K0B□	91	91.3	87	151	274.2	4.80×10 <sup>-4</sup>	4135	14300	19.0
	1/45	R88G-HPG50A451K5B□	67	124.5	87	100*2	373.9	4.70×10 <sup>-4</sup>	4538	15694	19.0
1.5 kW	1/5	R88G-HPG32A052K0B□	600	19.1	80	1000	57.2	3.90×10 <sup>-4</sup>	889	3542	7.4
	1/11	R88G-HPG32A112K0B□	273	45.6	87	454	136.9	3.40×10 <sup>-4</sup>	1126	4488	7.9
	1/21	R88G-HPG32A211K5B□	143	90.2	90	238	270.3	3.00×10 <sup>-4</sup>	1367	5448	7.9
	1/33	R88G-HPG50A332K0B□	91	141.7	90	136	424.7	4.80×10 <sup>-4</sup>	4135	14300	19.0
	1/45	R88G-HPG50A451K5B□	67	193.2	90	100*2	579.2	4.70×10 <sup>-4</sup>	4538	15694	19.0
2 kW	1/5	R88G-HPG32A052K0B□	600	26.8	84	1000	80.2	3.90×10 <sup>-4</sup>	889	3542	7.4
	1/11	R88G-HPG32A112K0B□	273	62.4	89	454	187.0	3.40×10 <sup>-4</sup>	1126	4488	7.9
	1/21	R88G-HPG50A212K0B□	143	119.1	89	214*2	357.0	5.80×10 <sup>-4</sup>	3611	12486	19.0
	1/33	R88G-HPG50A332K0B□	91	191.3	91	136*2	573.6	4.80×10 <sup>-4</sup>	4135	14300	19.0
3 kW	1/5	R88G-HPG32A053K0B□	600	42.0	88	1000	125.8	3.80×10 <sup>-4</sup>	889	3542	7.3
	1/11	R88G-HPG50A113K0B□	273	92.4	88	409*2	276.8	7.70×10 <sup>-4</sup>	2974	10285	19.0
	1/21	R88G-HPG50A213K0B□	143	182.5	91	214*2	546.5	5.80×10 <sup>-4</sup>	3611	12486	19.0
4 kW	1/5	R88G-HPG32A054K0B□	600	54.6	86	900*2	164.3	3.80×10 <sup>-4</sup>	889	3542	7.9
	1/11	R88G-HPG50A115K0B□	273	125.7	90	409*2	378.2	8.80×10 <sup>-4</sup>	2974	10285	19.1
5 kW	1/5	R88G-HPG50A055K0B□	600	70.0	88	900*2	209.9	1.20×10 <sup>-3</sup>	2347	8118	18.6
	1/11	R88G-HPG50A115K0B□	273	159.2	91	409*2	477.5	8.80×10 <sup>-4</sup>	2974	10285	19.1

\*1. The value is the maximum continuous output torque of the Reduction Gear. Do not exceed the torque.

\*2. The value is the allowable maximum rotation speed of the Reduction Gear. Do not exceed the motor shaft rotation speed over 4,500 r/min.

**Note:** 1. The value given for the reduction gear inertia is the Servomotor shaft conversion value.

2. The protection structure of the Servomotor with the reduction gear meets the requirements of IP44.

3. The value given for the allowable radial load is the value at the center of the shaft (T/2).

4. The standard shaft type is a straight shaft. A model with a key and tap is indicated by adding "J" to the end of the model number (the suffix shown in the box).

● For 2,000-r/min Servomotors (400 to 600 W, 1 to 5 kW)

Model		Rated rotation speed	Rated torque	Efficiency	Momentary maximum rotation speed	Momentary maximum torque	Reduction gear inertia	Allowable radial load	Allowable thrust load	Weight	
		r/min	N·m	%	r/min	N·m	kg·m <sup>2</sup>	N	N	kg	
400 W	1/5	R88G-HPG32A052K0B□	400	6.49	68	600	19.5	3.90×10 <sup>-4</sup>	889	3542	7.4
	1/11	R88G-HPG32A112K0B□	182	16.8	80	273	50.4	3.40×10 <sup>-4</sup>	1126	4488	7.9
	1/21	R88G-HPG32A211K5B□	95	34.1	85	143	102.3	3.00×10 <sup>-4</sup>	1367	5448	7.9
	1/33	R88G-HPG32A33600SB□	60	55.5	88	91	166.4	2.80×10 <sup>-4</sup>	1565	6240	7.9
	1/45	R88G-HPG32A45400SB□	44	73.9	86	67	221.8	2.70×10 <sup>-4</sup>	1718	6848	7.9
600 W	1/5	R88G-HPG32A052K0B□	400	11.2	78	600	33.5	3.90×10 <sup>-4</sup>	889	3542	7.4
	1/11	R88G-HPG32A112K0B□	182	26.7	85	273	80.3	3.40×10 <sup>-4</sup>	1126	4488	7.9
	1/21	R88G-HPG32A211K5B□	95	53.4	89	143	160.5	3.00×10 <sup>-4</sup>	1367	5448	7.9
	1/33	R88G-HPG32A33600SB□	60	85.9	91	91	258.0	2.80×10 <sup>-4</sup>	1565	6240	7.9
	1/45	R88G-HPG50A451K5B□	44	114.5	89	67	344.0	4.70×10 <sup>-4</sup>	4538	15694	19.0
1 kW	1/5	R88G-HPG32A053K0B□	400	20.3	85	600	60.8	3.90×10 <sup>-4</sup>	889	3542	7.3
	1/11	R88G-HPG32A112K0SB□	182	47.2	90	273	141.6	3.40×10 <sup>-4</sup>	1126	4488	7.8
	1/21	R88G-HPG32A211K0SB□	95	92.2	92	143	276.3	2.90×10 <sup>-4</sup>	1367	5448	7.8
	1/33	R88G-HPG50A332K0SB□	60	144.8	92	91	434.1	4.70×10 <sup>-4</sup>	4135	14300	19.0
	1/45	R88G-HPG50A451K0SB□	44	197.5	92	67	592.2	4.70×10 <sup>-4</sup>	4538	15694	19.0
1.5 kW	1/5	R88G-HPG32A053K0B□	400	31.8	89	600	95.7	3.80×10 <sup>-4</sup>	889	3542	7.3
	1/11	R88G-HPG32A112K0SB□	182	72.5	92	273	217.6	3.40×10 <sup>-4</sup>	1126	4488	7.8
	1/21	R88G-HPG50A213K0B□	95	138.3	92	143	415.4	5.80×10 <sup>-4</sup>	3611	12486	19.0
	1/33	R88G-HPG50A332K0SB□	60	219.7	93	91	659.8	4.70×10 <sup>-4</sup>	4135	14300	19.0
2 kW	1/5	R88G-HPG32A053K0B□	400	43.5	91	600	130.6	3.80×10 <sup>-4</sup>	889	3542	7.3
	1/11	R88G-HPG32A112K0SB□	182	97.7	93	273	293.6	3.40×10 <sup>-4</sup>	1126	4488	7.8
	1/21	R88G-HPG50A213K0B□	95	186.5	93	143	560.5	5.80×10 <sup>-4</sup>	3611	12486	19.0
	1/33	R88G-HPG50A332K0SB□	60	270.0*1	93	91	850.0*3	4.70×10 <sup>-4</sup>	4135	14300	19.0
3 kW	1/5	R88G-HPG32A054K0B□	400	64.4	90	600	197.8	3.80×10 <sup>-4</sup>	889	3542	7.9
	1/11	R88G-HPG50A115K0B□	182	144.7	92	273	435.2	8.80×10 <sup>-4</sup>	2974	10285	19.1
	1/21	R88G-HPG50A213K0SB□	95	260.0*1	93	143	839.8	6.90×10 <sup>-4</sup>	3611	12486	19.1
	1/25	R88G-HPG65A253K0SB□	80	321.8	90	120	967.5	3.00×10 <sup>-3</sup>	7846	28654	52.0
4 kW	1/5	R88G-HPG50A055K0SB□	400	86.9	91	600	260.7	1.10×10 <sup>-3</sup>	2347	8118	22.0
	1/11	R88G-HPG50A115K0SB□	182	195.4	93	273	586.2	8.40×10 <sup>-4</sup>	2974	10285	23.5
	1/20	R88G-HPG65A205K0SB□	100	347.6	91	150	1042.9	2.85×10 <sup>-3</sup>	7338	26799	55.4
	1/25	R88G-HPG65A255K0SB□	80	439.3	92	120	1317.9	2.81×10 <sup>-3</sup>	7846	28654	55.4
5 kW	1/5	R88G-HPG50A055K0SB□	400	109.9	92	600	329.4	1.10×10 <sup>-3</sup>	2347	8118	22.0
	1/11	R88G-HPG50A115K0SB□	182	200.0*1	93	273	732.5	8.40×10 <sup>-4</sup>	2974	10285	23.5
	1/20	R88G-HPG65A205K0SB□	100	439.7	92	150	1317.4	2.85×10 <sup>-3</sup>	7338	26799	55.4
	1/25	R88G-HPG65A255K0SB□	80	555.7	93	120	1664.7	2.81×10 <sup>-3</sup>	7846	28654	55.4

\*1. The value is the maximum continuous output torque of the Reduction Gear. Do not exceed the torque.  
 \*2. The value is the allowable maximum rotation speed of the Reduction Gear. Do not exceed the motor shaft rotation speed over 4,500 r/min.  
 \*3. The value is the maximum allowable torque of the Reduction Gear. Do not exceed the torque.

- Note:**
- The value given for the reduction gear inertia is the Servomotor shaft conversion value.
  - The protection structure of the Servomotor with the reduction gear meets the requirements of IP44.
  - The value given for the allowable radial load is the value at the center of the shaft (LR/2).
  - The standard shaft type is a straight shaft. A model with a key and tap is indicated by adding "J" to the end of the model number (the suffix shown in the box).

G5-Series  
System Configuration

EtherCAT Communications  
AC Servo Drive

EtherCAT Communications  
Linear Motor Type  
AC Servo Drive

General-purpose Inputs  
AC Servo Drive

ML-II Type  
AC Servo Drive

AC Servomotors

Linear Motor

Decelerator

# AC Servomotor/Drive G5-series

## ● For 1,000-r/min Servomotors (900 W to 3 kW)

Model		Rated rotation speed	Rated torque	Efficiency	Momentary maximum rotation speed	Momentary maximum torque	Reduction gear inertia	Allowable radial load	Allowable thrust load	Weight	
		r/min	N·m	%	r/min	N·m	kg·m <sup>2</sup>	N	N	kg	
900 W	1/5	R88G-HPG32A05900TB□	200	39.9	93	400	89.7	3.80×10 <sup>-4</sup>	889	3542	7.9
	1/11	R88G-HPG32A11900TB□	90	88.8	94	182	199.6	3.40×10 <sup>-4</sup>	1126	4488	8.4
	1/21	R88G-HPG50A21900TB□	47	169.6	94	95	381.0	7.00×10 <sup>-4</sup>	3611	12486	19.1
	1/33	R88G-HPG50A33900TB□	30	266.5	94	60	598.7	5.90×10 <sup>-4</sup>	4135	14300	19.1
2 kW	1/5	R88G-HPG32A052K0TB□	200	90.7	95	400	226.6	4.90×10 <sup>-4</sup>	889	3542	8.90
	1/11	R88G-HPG50A112K0TB□	90	197.5	94	182	493.2	8.40×10 <sup>-4</sup>	2974	10285	20.1
	1/21	R88G-HPG50A212K0TB□	47	260.0*1	95	95	850.0*1	6.50×10 <sup>-3</sup>	3611	12486	20.1
	1/25	R88G-HPG65A255K0SB□	40	448.9	94	80	1121.0	2.81×10 <sup>-3</sup>	7846	28654	55.4
3 kW	1/5	R88G-HPG50A055K0SB□	200	134.9	94	400	337.0	1.10×10 <sup>-3</sup>	2347	8118	22.0
	1/11	R88G-HPG50A115K0SB□	90	246.0*1	95	182	749.3	8.40×10 <sup>-4</sup>	2974	10285	23.5
	1/20	R88G-HPG65A205K0SB□	50	539.6	94	100	1348.0	2.85×10 <sup>-3</sup>	7338	26799	55.4
	1/25	R88G-HPG65A255K0SB□	40	674.5	94	80	1684.9	2.81×10 <sup>-3</sup>	7846	28654	55.4

\*1. The value is the maximum continuous output torque of the Reduction Gear. Do not exceed the torque.

**Note: 1.** The value given for the reduction gear inertia is the Servomotor shaft conversion value.

**2.** The protection structure of the Servomotor with the reduction gear meets the requirements of IP44.

**3.** The value given for the allowable radial load is the value at the center of the shaft (T/2).

**4.** The standard shaft type is a straight shaft. A model with a key and tap is indicated by adding "J" to the end of the model number (the suffix shown in the box).

**Backlash: 15 Arcminutes Max.**

● For 3,000-r/min Servomotors (50 to 750 W)

Model		Rated rotation speed	Rated torque	Efficiency	Momentary maximum rotation speed	Momentary maximum torque	Decelerat or inertia	Allowable radial load	Allowable thrust load	Weight	
		r/min	N•m	%	r/min	N•m	kg•m <sup>2</sup>	N	N	kg	
50 W	1/5	R88G-VRXF05B100CJ	600	0.66	82	1200	1.97	6.04×10 <sup>-6</sup>	392	196	0.55
	1/9	R88G-VRXF09B100CJ	333	1.18	82	667	3.54	4.97×10 <sup>-6</sup>	441	220	0.55
	1/15	R88G-VRXF15B100CJ	200	1.85	77	400	5.54	5.26×10 <sup>-6</sup>	588	294	0.70
	1/25	R88G-VRXF25B100CJ	120	3.08	77	240	9.24	5.14×10 <sup>-6</sup>	686	343	0.70
100 W	1/5	R88G-VRXF05B100CJ	600	1.44	90	1200	4.28	6.04×10 <sup>-6</sup>	392	196	0.55
	1/9	R88G-VRXF09B100CJ	333	2.59	90	667	7.7	4.97×10 <sup>-6</sup>	441	220	0.55
	1/15	R88G-VRXF15B100CJ	200	4.13	86	400	12.26	5.26×10 <sup>-6</sup>	588	294	0.70
	1/25	R88G-VRXF25B100CJ	120	6.88	86	240	20.43	5.14×10 <sup>-6</sup>	686	343	0.70
200 W	1/5	R88G-VRXF05B200CJ	600	2.94	92	1200	8.79	1.47×10 <sup>-5</sup>	392	196	0.72
	1/9	R88G-VRXF09C200CJ	333	4.78	83	667	14.27	2.37×10 <sup>-5</sup>	931	465	1.70
	1/15	R88G-VRXF15C200CJ	200	8.26	86	400	24.64	3.02×10 <sup>-5</sup>	1176	588	2.10
	1/25	R88G-VRXF25C200CJ	120	13.76	86	240	41.07	2.93×10 <sup>-5</sup>	1323	661	2.10
400 W	1/5	R88G-VRXF05C400CJ	600	5.72	88	1200	16.72	3.7×10 <sup>-5</sup>	784	392	1.70
	1/9	R88G-VRXF09C400CJ	333	10.30	88	667	30.10	2.37×10 <sup>-5</sup>	931	465	1.70
	1/15	R88G-VRXF15C400CJ	200	17.36	89	400	50.73	3.02×10 <sup>-5</sup>	1176	588	2.10
	1/25	R88G-VRXF25C400CJ	120	28.93	89	240	84.55	2.93×10 <sup>-5</sup>	1323	661	2.10
750 W (250 V)	1/5	R88G-VRXF05D750CJ	600	11.04	92	1200	32.66	8.17×10 <sup>-5</sup>	784	392	2.10
	1/9	R88G-VRXF09D750CJ	333	19.66	91	667	58.15	7.55×10 <sup>-5</sup>	1176	588	3.40
	1/15	R88G-VRXF15D750CJ	200	32.04	89	400	94.79	6.86×10 <sup>-5</sup>	1372	686	3.80
	1/25	R88G-VRXF25D750CJ	120	53.40	89	240	157.98	6.58×10 <sup>-5</sup>	1617	808	3.80

**Note: 1.** The value given for the Decelerator inertia is the Servomotor shaft conversion value.

**Note: 2.** The protective structure rating of the Servomotor combined with the Decelerator is IP44. (Excluding Decelerator and Servomotor connecting parts.)

**Note: 3.** The value given for the allowable radial load is the value at the center of the shaft (T/2).

**Note: 4.** The standard shaft type is a shaft with key and tap. (The key is temporarily assembled to the shaft.)

**Note: 5.** Take care so that the surface temperature of the Decelerator does not exceed 90°C.

G5-Series  
System Configuration

EtherCAT Communications  
AC Servo Drive

EtherCAT Communications  
Linear Motor Type  
AC Servo Drive

General-purpose Inputs  
AC Servo Drive

ML-II Type  
AC Servo Drive

AC Servomotors

Linear Motor

Decelerator

## External Dimensions

Backlash: 3 Arcminutes Max.

● For 3,000-r/min Servomotors (50 to 750 W)

Model			External view	Dimensions (mm)											
				LM	LR	C1	C2	D1	D2	D3	D4	D5	D6*2	E	F1
50 W	1/5	R88G-HPG11B05100B□	1*1	39.5	42	40	□40	46	46	40	39.5	29	---	27	2.2
	1/9	R88G-HPG11B09050B□	1*1	39.5	42	40	□40	46	46	40	39.5	29	---	27	2.2
	1/21	R88G-HPG14A21100B□	1	64.0	58	60	□60	70	46	56	55.5	40	---	37	2.5
	1/33	R88G-HPG14A33050B□	1	64.0	58	60	□60	70	46	56	55.5	40	---	37	2.5
	1/45	R88G-HPG14A45050B□	1	64.0	58	60	□60	70	46	56	55.5	40	---	37	2.5
100 W	1/5	R88G-HPG11B05100B□	1*1	39.5	42	40	□40	46	46	40	39.5	29	---	27	2.2
	1/11	R88G-HPG14A11100B□	1	64.0	58	60	□60	70	46	56	55.5	40	---	37	2.5
	1/21	R88G-HPG14A21100B□	1	64.0	58	60	□60	70	46	56	55.5	40	---	37	2.5
	1/33	R88G-HPG20A33100B□	2	66.5	80	90	55 dia.	105	46	85	84	59	89 dia.	53	7.5
200 W	1/5	R88G-HPG14A05200B□	1	64.0	58	60	□60	70	70	56	55.5	40	---	37	2.5
	1/11	R88G-HPG14A11200B□	1	64.0	58	60	□60	70	70	56	55.5	40	---	37	2.5
	1/21	R88G-HPG20A21200B□	2	71.0	80	90	89 dia.	105	70	85	84	59	---	53	7.5
	1/33	R88G-HPG20A33200B□	2	71.0	80	90	89 dia.	105	70	85	84	59	---	53	7.5
	1/45	R88G-HPG20A45200B□	2	71.0	80	90	89 dia.	105	70	85	84	59	---	53	7.5
400 W	1/5	R88G-HPG14A05400B□	1	64	58	60	□60	70	70	56	55.5	40	---	37	2.5
	1/11	R88G-HPG20A11400B□	2	71	80	90	89 dia.	105	70	85	84	59	---	53	7.5
	1/21	R88G-HPG20A21400B□	2	71	80	90	89 dia.	105	70	85	84	59	---	53	7.5
	1/33	R88G-HPG32A33400B□	2	104	133	120	122 dia.	135	70	115	114	84	---	98	12.5
	1/45	R88G-HPG32A45400B□	2	104	133	120	122 dia.	135	70	115	114	84	---	98	12.5
750 W (200 V)	1/5	R88G-HPG20A05750B□	1	78	80	90	□80	105	90	85	84	59	89 dia.	53	7.5
	1/11	R88G-HPG20A11750B□	1	78	80	90	□80	105	90	85	84	59	89 dia.	53	7.5
	1/21	R88G-HPG32A21750B□	2	104	133	120	122 dia.	135	90	115	114	84	---	98	12.5
	1/33	R88G-HPG32A33750B□	2	104	133	120	122 dia.	135	90	115	114	84	---	98	12.5
	1/45	R88G-HPG32A45750B□	2	104	133	120	122 dia.	135	90	115	114	84	---	98	12.5
750 W (400 V)	1/5	R88G-HPG32A052K0B□	2	110	133	120	135 dia.	135	115	115	114	84	---	98	12.5
	1/11	R88G-HPG32A112K0B□	2	110	133	120	135 dia.	135	115	115	114	84	---	98	12.5
	1/21	R88G-HPG32A211K5B□	2	110	133	120	135 dia.	135	115	115	114	84	---	98	12.5
	1/33	R88G-HPG32A33600SB□	2	110	133	120	135 dia.	135	115	115	114	84	---	98	12.5
	1/45	R88G-HPG50A451K5B□	2	123	156	170	170 dia.	190	115	165	163	122	---	103	12

- Note:**
- The standard shaft type is a straight shaft.
  - A model with a key and tap is indicated by adding "J" to the end of the model number (the suffix shown in the box).  
(Example : R88G-HPG11B05100BJ)
  - The diameter of the motor shaft insertion is same as of the corresponding Servomotor shaft.
  - Applicable for the servomotors with key, if the key is removed.
  - The external dimensions diagrams in this manual provide only the main dimensions. They are not intended to show the detail shapes of the products.

### External view 1

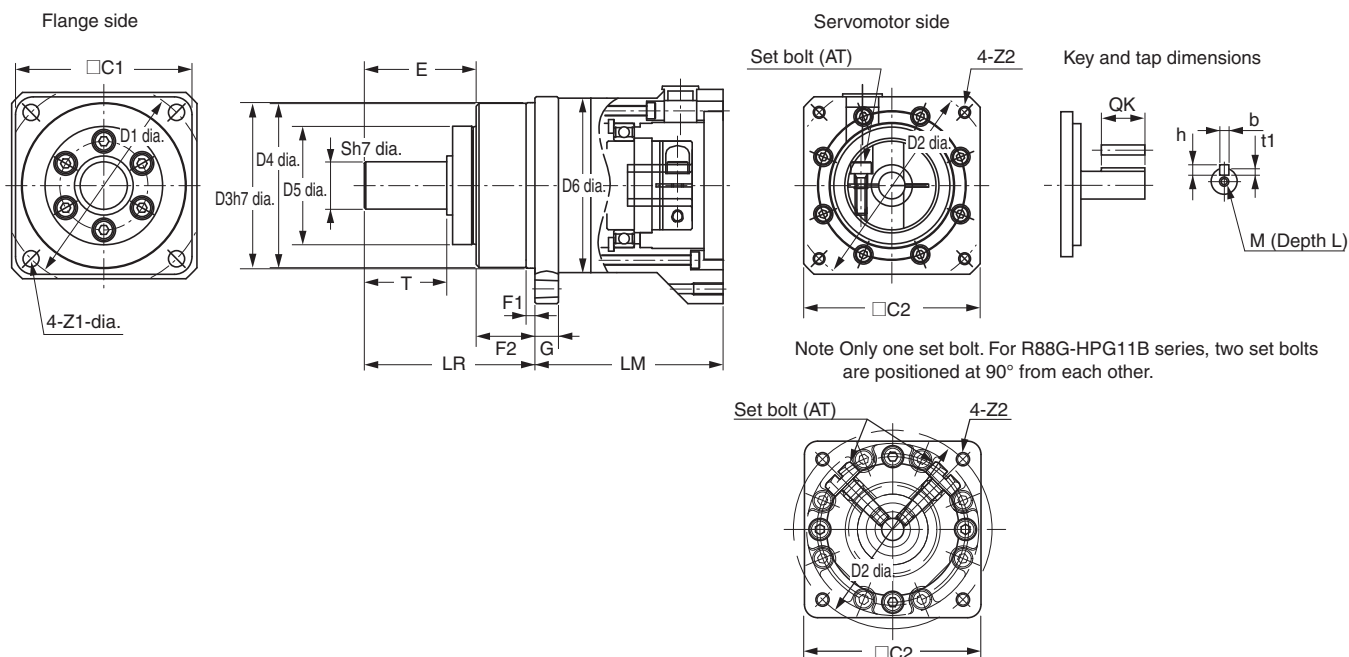

	Dimensions (mm)												Model			
	F2	G	S	T	Z1	Z2	AT*3	Key				Tap				
								QK	b	h	t1	M	L			
	15	5	8	20	3.4	M4×9	M3	15	3	3	1.8	M3	6	R88G-HPG11B05100B□	1/5	50 W
	15	5	8	20	3.4	M4×9	M3	15	3	3	1.8	M3	6	R88G-HPG11B09050B□	1/9	
	21	8	16	28	5.5	M4×10	M3	25	5	5	3	M4	8	R88G-HPG14A21100B□	1/21	
	21	8	16	28	5.5	M4×10	M3	25	5	5	3	M4	8	R88G-HPG14A33050B□	1/33	
	21	8	16	28	5.5	M4×10	M3	25	5	5	3	M4	8	R88G-HPG14A45050B□	1/45	
	15	5	8	20	3.4	M4×9	M3	15	3	3	1.8	M3	6	R88G-HPG11B05100B□	1/5	100 W
	21	8	16	28	5.5	M4×10	M3	25	5	5	3	M4	8	R88G-HPG14A11100B□	1/11	
	21	8	16	28	5.5	M4×10	M3	25	5	5	3	M4	8	R88G-HPG14A21100B□	1/21	
	27	10	25	42	9	M4×10	M4	36	8	7	4	M6	12	R88G-HPG20A33100B□	1/33	100 W
	27	10	25	42	9	M4×10	M4	36	8	7	4	M6	12	R88G-HPG20A45100B□	1/45	
	21	8	16	28	5.5	M4×10	M4	25	5	5	3	M4	8	R88G-HPG14A05200B□	1/5	200 W
	21	8	16	28	5.5	M4×10	M4	25	5	5	3	M4	8	R88G-HPG14A11200B□	1/11	
	27	10	25	42	9	M4×10	M4	36	8	7	4	M6	12	R88G-HPG20A21200B□	1/21	
	27	10	25	42	9	M4×10	M4	36	8	7	4	M6	12	R88G-HPG20A33200B□	1/33	200 W
	27	10	25	42	9	M4×10	M4	36	8	7	4	M6	12	R88G-HPG20A45200B□	1/45	
	21	8	16	28	5.5	M4×10	M4	25	5	5	3	M4	8	R88G-HPG14A05400B□	1/5	400 W
	27	10	25	42	9	M4×10	M4	36	8	7	4	M6	12	R88G-HPG20A11400B□	1/11	
	27	10	25	42	9	M4×10	M4	36	8	7	4	M6	12	R88G-HPG20A21400B□	1/21	
	35	13	40	82	11	M4×10	M4	70	12	8	5	M10	20	R88G-HPG32A33400B□	1/33	400 W
	35	13	40	82	11	M4×10	M4	70	12	8	5	M10	20	R88G-HPG32A45400B□	1/45	
	27	10	25	42	9	M5×12	M4	36	8	7	4	M6	12	R88G-HPG20A05750B□	1/5	750 W (200 V)
	27	10	25	42	9	M5×12	M4	36	8	7	4	M6	12	R88G-HPG20A11750B□	1/11	
	35	13	40	82	11	M5×12	M6	70	12	8	5	M10	20	R88G-HPG32A21750B□	1/21	
	35	13	40	82	11	M5×12	M6	70	12	8	5	M10	20	R88G-HPG32A33750B□	1/33	750 W (200 V)
	35	13	40	82	11	M5×12	M6	70	12	8	5	M10	20	R88G-HPG32A45750B□	1/45	
	35	13	40	82	11	M8×10	M6	70	12	8	5	M10	20	R88G-HPG32A052K0B□	1/5	750 W (400 V)
	35	13	40	82	11	M8×10	M6	70	12	8	5	M10	20	R88G-HPG32A112K0B□	1/11	
	35	13	40	82	11	M8×10	M6	70	12	8	5	M10	20	R88G-HPG32A211K5B□	1/21	
	35	13	40	82	11	M8×10	M6	70	12	8	5	M10	20	R88G-HPG32A33600SB□	1/33	750 W (400 V)
	53	16	50	82	14	M8×10	M6	70	14	9	5.5	M10	20	R88G-HPG50A451K5B□	1/45	

\*1. Two set bolts are positioned at 90° from each other.

\*2. D6 is the maximum diameter of the decelerator body between the flange side and Servomotor side. (See Outline Drawing) The value is given only when the diameter is larger than the diameters of these two sides. Take heed of this when you mount the decelerator to the machine.

\*3. Indicates set bolt.

## External view 2

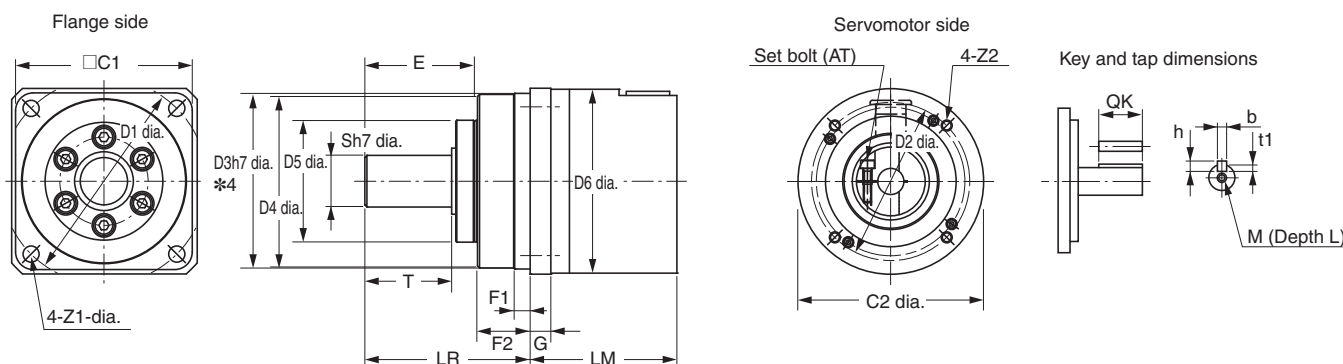

\*4. The tolerance is "h8" for R88G-HPG50□.

# AC Servomotor/Drive G5-series

## ● For 3,000-r/min Servomotors (1 to 5 kW)

Model			External view	Dimensions (mm)											
				LM	LR	C1	C2	D1	D2	D3	D4	D5	D6*1	E	F1
1 kW	1/5	R88G-HPG32A052K0B□	2	110	133	120	135 dia.	135	115	115	114	84	---	98	12.5
	1/11	R88G-HPG32A112K0B□	2	110	133	120	135 dia.	135	115	115	114	84	---	98	12.5
	1/21	R88G-HPG32A211K5B□	2	110	133	120	135 dia.	135	115	115	114	84	---	98	12.5
	1/33	R88G-HPG50A332K0B□	2	123	156	170	170 dia.	190	115	165	163	122	---	103	12
	1/45	R88G-HPG50A451K5B□	2	123	156	170	170 dia.	190	115	165	163	122	---	103	12
1.5 kW	1/5	R88G-HPG32A052K0B□	2	110	133	120	135 dia.	135	115	115	114	84	---	98	12.5
	1/11	R88G-HPG32A112K0B□	2	110	133	120	135 dia.	135	115	115	114	84	---	98	12.5
	1/21	R88G-HPG32A211K5B□	2	110	133	120	135 dia.	135	115	115	114	84	---	98	12.5
	1/33	R88G-HPG50A332K0B□	2	123	156	170	170 dia.	190	115	165	163	122	---	103	12
	1/45	R88G-HPG50A451K5B□	2	123	156	170	170 dia.	190	115	165	163	122	---	103	12
2 kW	1/5	R88G-HPG32A052K0B□	2	110	133	120	135 dia.	135	115	115	114	84	---	98	12.5
	1/11	R88G-HPG32A112K0B□	2	110	133	120	135 dia.	135	115	115	114	84	---	98	12.5
	1/21	R88G-HPG50A212K0B□	2	123	156	170	170 dia.	190	115	165	163	122	---	103	12
	1/33	R88G-HPG50A332K0B□	2	123	156	170	170 dia.	190	115	165	163	122	---	103	12
3 kW	1/5	R88G-HPG32A053K0B□	1	107	133	120	□130	135	145	115	114	84	---	98	12.5
	1/11	R88G-HPG50A113K0B□	2	123	156	170	170 dia.	190	145	165	163	122	---	103	12
	1/21	R88G-HPG50A213K0B□	2	123	156	170	170 dia.	190	145	165	163	122	---	103	12
4 kW	1/5	R88G-HPG32A054K0B□	1	129	133	120	□130	135	145	115	114	84	---	98	12.5
	1/11	R88G-HPG50A115K0B□	1	149	156	170	□130	190	145	165	163	122	170 dia.	103	12
5 kW	1/5	R88G-HPG50A055K0B□	1	149	156	170	□130	190	145	165	163	122	170 dia.	103	12
	1/11	R88G-HPG50A115K0B□	1	149	156	170	□130	190	145	165	163	122	170 dia.	103	12

- Note:**
- The standard shaft type is a straight shaft.
  - A model with a key and tap is indicated by adding "J" to the end of the model number (the suffix shown in the box).  
(Example : R88G-HPG32A052K0BJ)
  - The diameter of the motor shaft insertion is same as of the corresponding Servomotor shaft.
  - Applicable for the servomotors with key, if the key is removed.
  - The external dimensions diagrams in this manual provide only the main dimensions. They are not intended to show the detail shapes of the products.

### External view 1

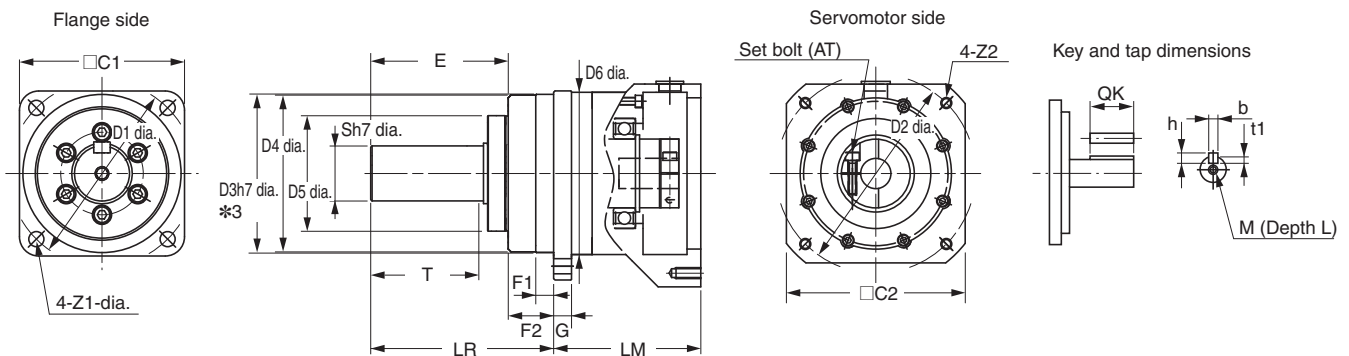

\*3. The tolerance is "h8" for R88G-HPG50□.

	Dimensions (mm)													Model		
	F2	G	S	T	Z1	Z2	AT*2	Key				Tap				
								QK	b	h	t1	M	L			
	35	13	40	82	11	M8×10	M6	70	12	8	5	M10	20	R88G-HPG32A052K0B□	1/5	1 kW
	35	13	40	82	11	M8×10	M6	70	12	8	5	M10	20	R88G-HPG32A112K0B□	1/11	
	35	13	40	82	11	M8×10	M6	70	12	8	5	M10	20	R88G-HPG32A211K5B□	1/21	
	53	16	50	82	14	M8×10	M6	70	14	9	5.5	M10	20	R88G-HPG50A332K0B□	1/33	
	53	16	50	82	14	M8×10	M6	70	14	9	5.5	M10	20	R88G-HPG50A451K5B□	1/45	
	35	13	40	82	11	M8×10	M6	70	12	8	5	M10	20	R88G-HPG32A052K0B□	1/5	1.5 kW
	35	13	40	82	11	M8×10	M6	70	12	8	5	M10	20	R88G-HPG32A112K0B□	1/11	
	35	13	40	82	11	M8×10	M6	70	12	8	5	M10	20	R88G-HPG32A211K5B□	1/21	
	53	16	50	82	14	M8×10	M6	70	14	9	5.5	M10	20	R88G-HPG50A332K0B□	1/33	
	53	16	50	82	14	M8×10	M6	70	14	9	5.5	M10	20	R88G-HPG50A451K5B□	1/45	
	35	13	40	82	11	M8×10	M6	70	12	8	5	M10	20	R88G-HPG32A052K0B□	1/5	2 kW
	35	13	40	82	11	M8×10	M6	70	12	8	5	M10	20	R88G-HPG32A112K0B□	1/11	
	53	16	50	82	14	M8×10	M6	70	14	9	5.5	M10	20	R88G-HPG50A212K0B□	1/21	
	53	16	50	82	14	M8×10	M6	70	14	9	5.5	M10	20	R88G-HPG50A332K0B□	1/33	3 kW
	35	13	40	82	11	M8×18	M6	70	12	8	5	M10	20	R88G-HPG32A053K0B□	1/5	
	53	16	50	82	14	M8×16	M6	70	14	9	5.5	M10	20	R88G-HPG50A113K0B□	1/11	
	53	16	50	82	14	M8×16	M6	70	14	9	5.5	M10	20	R88G-HPG50A213K0B□	1/21	4 kW
	35	13	40	82	11	M8×25	M6	70	12	8	5	M10	20	R88G-HPG32A054K0B□	1/5	
	53	16	50	82	14	M8×25	M6	70	14	9	5.5	M10	20	R88G-HPG50A115K0B□	1/11	
	53	16	50	82	14	M8×25	M6	70	14	9	5.5	M10	20	R88G-HPG50A055K0B□	1/5	5 kW
	53	16	50	82	14	M8×25	M6	70	14	9	5.5	M10	20	R88G-HPG50A115K0B□	1/11	

\*1. D6 is the maximum diameter of the decelerator body between the flange side and Servomotor side. (See Outline Drawing) The value is given only when the diameter is larger than the diameters of these two sides. Take heed of this when you mount the decelerator to the machine.

\*2. Indicates set bolt.

### External view 2

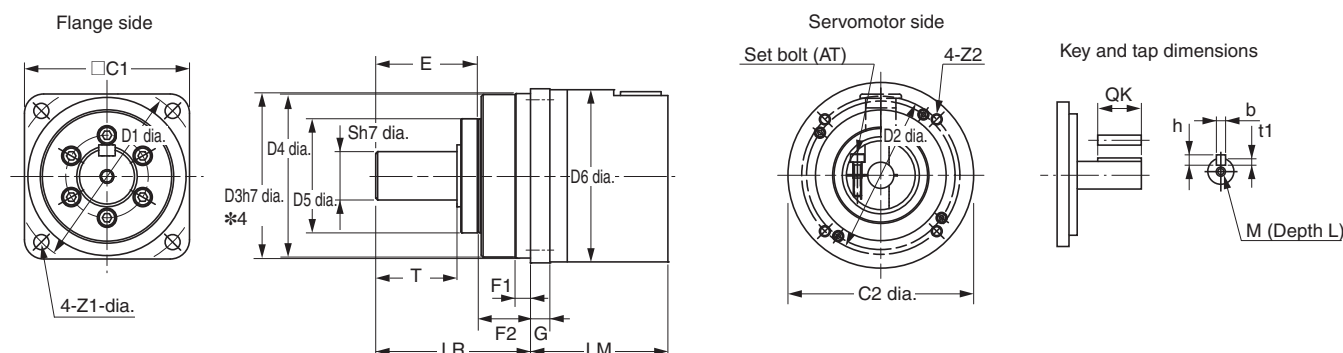

\*4. The tolerance is "h8" for R88G-HPG50□.

# AC Servomotor/Drive G5-series

## ● For 2,000-r/min Servomotors (400 W to 5 kW)

Model			External view	Dimensions (mm)											
				LM	LR	C1	C2	D1	D2	D3	D4	D5	D6*1	E	F1
400 W (400 V)	1/5	R88G-HPG32A052K0B□	2	110	133	120	135 dia.	135	115	115	114	84	---	98	12.5
	1/11	R88G-HPG32A112K0B□	2	110	133	120	135 dia.	135	115	115	114	84	---	98	12.5
	1/21	R88G-HPG32A211K5B□	2	110	133	120	135 dia.	135	115	115	114	84	---	98	12.5
	1/33	R88G-HPG32A33600SB□	2	110	133	120	135 dia.	135	115	115	114	84	---	98	12.5
	1/45	R88G-HPG32A45400SB□	2	110	133	120	135 dia.	135	115	115	114	84	---	98	12.5
600 W (400 V)	1/5	R88G-HPG32A052K0B□	2	110	133	120	135 dia.	135	115	115	114	84	---	98	12.5
	1/11	R88G-HPG32A112K0B□	2	110	133	120	135 dia.	135	115	115	114	84	---	98	12.5
	1/21	R88G-HPG32A211K5B□	2	110	133	120	135 dia.	135	115	115	114	84	---	98	12.5
	1/33	R88G-HPG32A33600SB□	2	110	133	120	135 dia.	135	115	115	114	84	---	98	12.5
	1/45	R88G-HPG50A451K5B□	2	123	156	170	170 dia.	190	115	165	163	122	---	103	12
1 kW	1/5	R88G-HPG32A053K0B□	1	107	133	120	□130	135	145	115	114	84	---	98	12.5
	1/11	R88G-HPG32A112K0SB□	1	107	133	120	□130	135	145	115	114	84	---	98	12.5
	1/21	R88G-HPG32A211K0SB□	1	107	133	120	□130	135	145	115	114	84	---	98	12.5
	1/33	R88G-HPG50A332K0SB□	2	123	156	170	170 dia.	190	145	165	163	122	---	103	12
	1/45	R88G-HPG50A451K0SB□	2	123	156	170	170 dia.	190	145	165	163	122	---	103	12
1.5 kW	1/5	R88G-HPG32A053K0B□	1	107	133	120	□130	135	145	115	114	84	---	98	12.5
	1/11	R88G-HPG32A112K0SB□	1	107	133	120	□130	135	145	115	114	84	---	98	12.5
	1/21	R88G-HPG50A213K0B□	2	123	156	170	170 dia.	190	145	165	163	122	---	103	12
	1/33	R88G-HPG50A332K0SB□	2	123	156	170	170 dia.	190	145	165	163	122	---	103	12
2 kW	1/5	R88G-HPG32A053K0B□	1	107	133	120	□130	135	145	115	114	84	---	98	12.5
	1/11	R88G-HPG32A112K0SB□	1	107	133	120	□130	135	145	115	114	84	---	98	12.5
	1/21	R88G-HPG50A213K0B□	2	123	156	170	170 dia.	190	145	165	163	122	---	103	12
	1/33	R88G-HPG50A332K0SB□	2	123	156	170	170 dia.	190	145	165	163	122	---	103	12
3 kW	1/5	R88G-HPG32A054K0B□	1	129	133	120	□130	135	145	115	114	84	---	98	12.5
	1/11	R88G-HPG50A115K0B□	1	149	156	170	□130	190	145	165	163	122	170 dia.	103	12
	1/21	R88G-HPG50A213K0SB□	1	149	156	170	□130	190	145	165	163	122	170 dia.	103	12
	1/25	R88G-HPG65A253K0SB□	1	231	222	230	□130	260	145	220	214	168	220 dia.	165	12
4 kW	1/5	R88G-HPG50A055K0SB□	1	149	156	170	□180	190	200	165	163	122	---	103	12
	1/11	R88G-HPG50A115K0SB□	1	149	156	170	□180	190	200	165	163	122	---	103	12
	1/20	R88G-HPG65A205K0SB□	1	231	222	230	□180	260	200	220	214	168	220 dia.	165	12
	1/25	R88G-HPG65A255K0SB□	1	231	222	230	□180	260	200	220	214	168	220 dia.	165	12
5 kW	1/5	R88G-HPG50A055K0SB□	1	149	156	170	□180	190	200	165	163	122	---	103	12
	1/11	R88G-HPG50A115K0SB□	1	149	156	170	□180	190	200	165	163	122	---	103	12
	1/20	R88G-HPG65A205K0SB□	1	231	222	230	□180	260	200	220	214	168	220 dia.	165	12
	1/25	R88G-HPG65A255K0SB□	1	231	222	230	□180	260	200	220	214	168	220 dia.	165	12

- Note:**
- The standard shaft type is a straight shaft.
  - A model with a key and tap is indicated by adding "J" to the end of the model number (the suffix shown in the box). (Example : R88G-HPG32A053K0BJ)
  - The diameter of the motor shaft insertion is same as of the corresponding Servomotor shaft.
  - Applicable for the servomotors with key, if the key is removed.
  - The external dimensions diagrams in this manual provide only the main dimensions. They are not intended to show the detail shapes of the products.

### External view 1

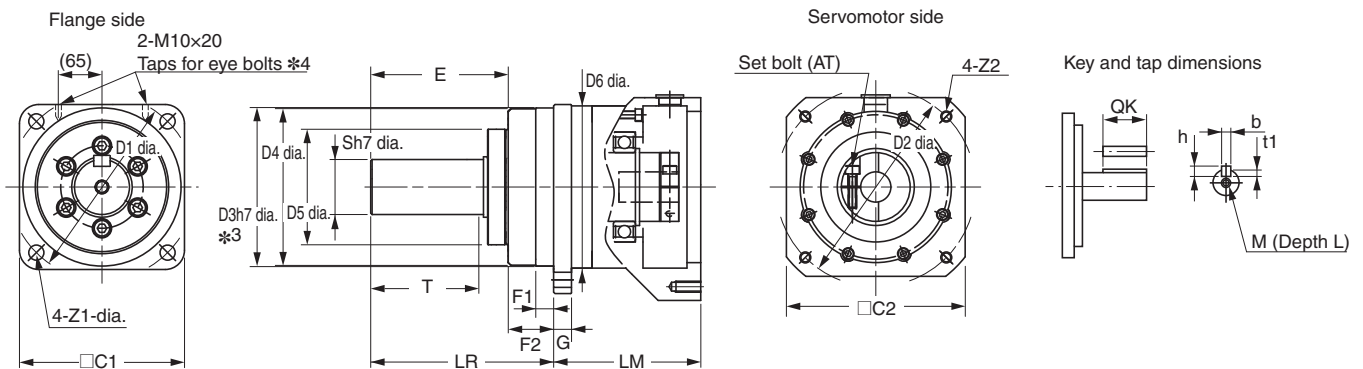

- \*3. The tolerance is "h8" for R88G-HPG50□ and R88G-HPG65□.  
 \*4. The model R88G-HPG65□ has the taps for eye bolts.

	Dimensions (mm)													Model		
	F2	G	S	T	Z1	Z2	AT*2	Key				Tap				
								QK	b	h	t1	M	L			
	35	13	40	82	11	M8×10	M6	70	12	8	5	M10	20	R88G-HPG32A052K0B□	1/5	400 W (400 V)
	35	13	40	82	11	M8×10	M6	70	12	8	5	M10	20	R88G-HPG32A112K0B□	1/11	
	35	13	40	82	11	M8×10	M6	70	12	8	5	M10	20	R88G-HPG32A211K5B□	1/21	
	35	13	40	82	11	M8×10	M6	70	12	8	5	M10	20	R88G-HPG32A33600SB□	1/33	
	35	13	40	82	11	M8×10	M6	70	12	8	5	M10	20	R88G-HPG32A45400SB□	1/45	
	35	13	40	82	11	M8×10	M6	70	12	8	5	M10	20	R88G-HPG32A052K0B□	1/5	600 W (400 V)
	35	13	40	82	11	M8×10	M6	70	12	8	5	M10	20	R88G-HPG32A112K0B□	1/11	
	35	13	40	82	11	M8×10	M6	70	12	8	5	M10	20	R88G-HPG32A211K5B□	1/21	
	35	13	40	82	11	M8×10	M6	70	12	8	5	M10	20	R88G-HPG32A33600SB□	1/33	
	35	13	40	82	11	M8×10	M6	70	12	8	5	M10	20	R88G-HPG32A45400SB□	1/45	
	53	16	50	82	14	M8×10	M6	70	14	9	5.5	M10	20	R88G-HPG50A451K5B□	1/45	1 kW
	35	13	40	82	11	M8×18	M6	70	12	8	5	M10	20	R88G-HPG32A053K0B□	1/5	
	35	13	40	82	11	M8×18	M6	70	12	8	5	M10	20	R88G-HPG32A112K0SB□	1/11	
	35	13	40	82	11	M8×18	M6	70	12	8	5	M10	20	R88G-HPG32A211K0SB□	1/21	
	53	16	50	82	14	M8×16	M6	70	14	9	5.5	M10	20	R88G-HPG50A332K0SB□	1/33	
	53	16	50	82	14	M8×16	M6	70	14	9	5.5	M10	20	R88G-HPG50A451K0SB□	1/45	1.5 kW
	35	13	40	82	11	M8×18	M6	70	12	8	5	M10	20	R88G-HPG32A053K0B□	1/5	
	35	13	40	82	11	M8×18	M6	70	12	8	5	M10	20	R88G-HPG32A112K0SB□	1/11	
	53	16	50	82	14	M8×16	M6	70	14	9	5.5	M10	20	R88G-HPG50A213K0B□	1/21	
	53	16	50	82	14	M8×16	M6	70	14	9	5.5	M10	20	R88G-HPG50A332K0SB□	1/33	
	35	13	40	82	11	M8×18	M6	70	12	8	5	M10	20	R88G-HPG32A053K0B□	1/5	2 kW
	35	13	40	82	11	M8×18	M6	70	12	8	5	M10	20	R88G-HPG32A112K0SB□	1/11	
	53	16	50	82	14	M8×16	M6	70	14	9	5.5	M10	20	R88G-HPG50A213K0B□	1/21	
	53	16	50	82	14	M8×16	M6	70	14	9	5.5	M10	20	R88G-HPG50A332K0SB□	1/33	
	35	13	40	82	11	M8×25	M6	70	12	8	5	M10	20	R88G-HPG32A054K0B□	1/5	
	53	16	50	82	14	M8×25	M6	70	14	9	5.5	M10	20	R88G-HPG50A115K0B□	1/11	
	53	16	50	82	14	M8×25	M6	70	14	9	5.5	M10	20	R88G-HPG50A213K0SB□	1/21	
	57	25	80	130	18	M8×25	M8	110	22	14	9	M16	35	R88G-HPG65A253K0SB□	1/25	
	53	16	50	82	14	M12×25	M6	70	14	9	5.5	M10	20	R88G-HPG50A055K0SB□	1/5	4 kW
	53	16	50	82	14	M12×25	M6	70	14	9	5.5	M10	20	R88G-HPG50A115K0SB□	1/11	
	57	25	80	130	18	M12×25	M8	110	22	14	9	M16	35	R88G-HPG65A205K0SB□	1/20	
	57	25	80	130	18	M12×25	M8	110	22	14	9	M16	35	R88G-HPG65A255K0SB□	1/25	
	53	16	50	82	14	M12×25	M6	70	14	9	5.5	M10	20	R88G-HPG50A055K0SB□	1/5	
	53	16	50	82	14	M12×25	M6	70	14	9	5.5	M10	20	R88G-HPG50A115K0SB□	1/11	
	57	25	80	130	18	M12×25	M8	110	22	14	9	M16	35	R88G-HPG65A205K0SB□	1/20	
	57	25	80	130	18	M12×25	M8	110	22	14	9	M16	35	R88G-HPG65A255K0SB□	1/25	

\*1. D6 is the maximum diameter of the decelerator body between the flange side and Servomotor side. (See Outline Drawing) The value is given only when the diameter is larger than the diameters of these two sides. Take heed of this when you mount the decelerator to the machine.  
 \*2. Indicates set bolt.

### External view 2

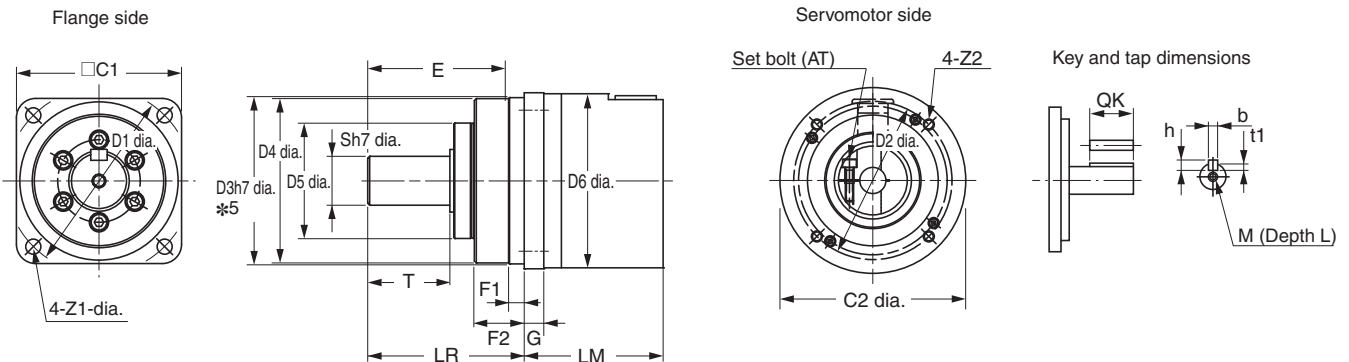

\*5. The tolerance is "h8" for R88G-HPG50□.

G5-Series System Configuration  
 EtherCAT Communications AC Servo Drive  
 EtherCAT Communications Linear Motor Type AC Servo Drive  
 General-purpose Inputs AC Servo Drive  
 ML-II Type AC Servo Drive  
 AC Servomotors  
 Linear Motor  
 Decelerator

# AC Servomotor/Drive G5-series

## ● For 1,000-r/min Servomotors (900 W to 3 kW)

Model			External view	Dimensions (mm)											
				LM	LR	C1	C2	D1	D2	D3	D4	D5	D6*1	E	F1
900 W	1/5	R88G-HPG32A05900TB□	1	129	133	120	□130	135	145	115	114	84	---	98	12.5
	1/11	R88G-HPG32A11900TB□	1	129	133	120	□130	135	145	115	114	84	---	98	12.5
	1/21	R88G-HPG50A21900TB□	1	149	156	170	□130	190	145	165	163	122	170 dia.	103	12
	1/33	R88G-HPG50A33900TB□	1	149	156	170	□130	190	145	165	163	122	170 dia.	103	12
2 kW	1/5	R88G-HPG32A052K0TB□	1	129	133	120	□180	135	200	115	114	84	---	98	12.5
	1/11	R88G-HPG50A112K0TB□	1	149	156	170	□180	190	200	165	163	122	---	103	12
	1/21	R88G-HPG50A212K0TB□	1	149	156	170	□180	190	200	165	163	122	---	103	12
	1/25	R88G-HPG65A255K0SB□	1	231	222	230	□180	260	200	220	214	168	220 dia.	165	12
3 kW	1/5	R88G-HPG50A055K0SB□	1	149	156	170	□180	190	200	165	163	122	---	103	12
	1/11	R88G-HPG50A115K0SB□	1	149	156	170	□180	190	200	165	163	122	---	103	12
	1/20	R88G-HPG65A205K0SB□	1	231	222	230	□180	260	200	220	214	168	220 dia.	165	12
	1/25	R88G-HPG65A255K0SB□	1	231	222	230	□180	260	200	220	214	168	220 dia.	165	12

- Note:**
1. The standard shaft type is a straight shaft.
  2. A model with a key and tap is indicated by adding "J" to the end of the model number (the suffix shown in the box).  
(Example : R88G-HPG32A05900TBJ)
  3. The diameter of the motor shaft insertion is same as of the corresponding Servomotor shaft.
  4. Applicable for the servomotors with key, if the key is removed.
  5. The external dimensions diagrams in this manual provide only the main dimensions. They are not intended to show the detail shapes of the products.

### External view 1

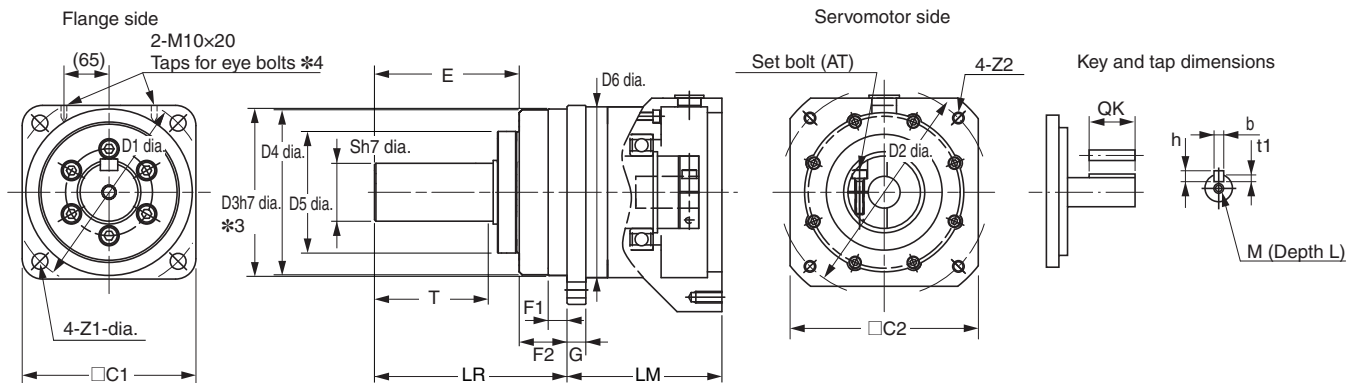

\*3. The tolerance is "h8" for R88G-HPG50□ and R88G-HPG65□.

\*4. The model R88G-HPG65□ has the taps for eye bolts.

	Dimensions (mm)													Model		
	F2	G	S	T	Z1	Z2	AT*2	Key				Tap				
								QK	b	h	t1	M	L			
	35	13	40	82	11	M8×25	M6	70	12	8	5	M10	20	R88G-HPG32A05900TB□	1/5	900 W
	35	13	40	82	11	M8×25	M6	70	12	8	5	M10	20	R88G-HPG32A11900TB□	1/11	
	53	16	50	82	14	M8×25	M6	70	14	9	5.5	M10	20	R88G-HPG50A21900TB□	1/21	
	53	16	50	82	14	M8×25	M6	70	14	9	5.5	M10	20	R88G-HPG50A33900TB□	1/33	
	35	13	40	82	11	M12×25	M6	70	12	8	5	M10	20	R88G-HPG32A052K0TB□	1/5	2 kW
	53	16	50	82	14	M12×25	M6	70	14	9	5.5	M10	20	R88G-HPG50A112K0TB□	1/11	
	53	16	50	82	14	M12×25	M6	70	14	9	5.5	M10	20	R88G-HPG50A212K0TB□	1/21	
	57	25	80	130	18	M12×25	M8	110	22	14	9	M16	35	R88G-HPG65A255K0SB□	1/25	
	53	16	50	82	14	M12×25	M6	70	14	9	5.5	M10	20	R88G-HPG50A055K0SB□	1/5	3 kW
	53	16	50	82	14	M12×25	M6	70	14	9	5.5	M10	20	R88G-HPG50A115K0SB□	1/11	
	57	25	80	130	18	M12×25	M8	110	22	14	9	M16	35	R88G-HPG65A205K0SB□	1/20	
	57	25	80	130	18	M12×25	M8	110	22	14	9	M16	35	R88G-HPG65A255K0SB□	1/25	

\*1. D6 is the maximum diameter of the decelerator body between the flange side and Servomotor side. (See Outline Drawing) The value is given only when the diameter is larger than the diameters of these two sides. Take heed of this when you mount the decelerator to the machine.

\*2. Indicates set bolt.

G5-Series  
System Configuration

EtherCAT Communications  
AC Servo Drive

EtherCAT Communications  
Linear Motor Type  
AC Servo Drive

General-purpose Inputs  
AC Servo Drive

ML-II Type  
AC Servo Drive

AC Servomotors

Linear Motor

Decelerator

## Backlash: 15 Arcminutes Max.

### ● For 3,000-r/min Servomotors (50 to 750 W)

Model			Dimensions [mm]										
			LM	LR	C1	C2	D1	D2	D3	F	G	S	T
50 W	1/5	R88G-VRXF05B100CJ	67.5	32	40	52	46	60	50	3	6	12	20
	1/9	R88G-VRXF09B100CJ	67.5	32	40	52	46	60	50	3	6	12	20
	1/15	R88G-VRXF15B100CJ	78.0	32	40	52	46	60	50	3	6	12	20
	1/25	R88G-VRXF25B100CJ	78.0	32	40	52	46	60	50	3	6	12	20
100 W	1/5	R88G-VRXF05B100CJ	67.5	32	40	52	46	60	50	3	6	12	20
	1/9	R88G-VRXF09B100CJ	67.5	32	40	52	46	60	50	3	6	12	20
	1/15	R88G-VRXF15B100CJ	78.0	32	40	52	46	60	50	3	6	12	20
	1/25	R88G-VRXF25B100CJ	78.0	32	40	52	46	60	50	3	6	12	20
200 W	1/5	R88G-VRXF05B200CJ	72.5	32	60	52	70	60	50	3	10	12	20
	1/9	R88G-VRXF09C200CJ	89.5	50	60	78	70	90	70	3	8	19	30
	1/15	R88G-VRXF15C200CJ	100.0	50	60	78	70	90	70	3	8	19	30
	1/25	R88G-VRXF25C200CJ	100.0	50	60	78	70	90	70	3	8	19	30
400 W	1/5	R88G-VRXF05C400CJ	89.5	50	60	78	70	90	70	3	8	19	30
	1/9	R88G-VRXF09C400CJ	89.5	50	60	78	70	90	70	3	8	19	30
	1/15	R88G-VRXF15C400CJ	100.0	50	60	78	70	90	70	3	8	19	30
	1/25	R88G-VRXF25C400CJ	100.0	50	60	78	70	90	70	3	8	19	30
750 W (200 V)	1/5	R88G-VRXF05C750CJ	93.5	50	80	78	90	90	70	3	10	19	30
	1/9	R88G-VRXF09D750CJ	97.5	61	80	98	90	115	90	5	10	24	40
	1/15	R88G-VRXF15D750CJ	110.0	61	80	98	90	115	90	5	10	24	40
	1/25	R88G-VRXF25D750CJ	110.0	61	80	98	90	115	90	5	10	24	40

**Note 1.** The standard shaft type is a shaft with key and tap.

**Note 2.** The diameter of the motor shaft insertion is same as of the corresponding Servomotor shaft.

**Note 3.** If the key on a Servomotor with key is uninstalled, it is possible to use the Decelerator by installing the Servomotor without above mentioned key.

**Note 4.** The external dimensions diagrams in this manual provide only the main dimensions. They are not intended to show the detail shapes of the products.

### External view

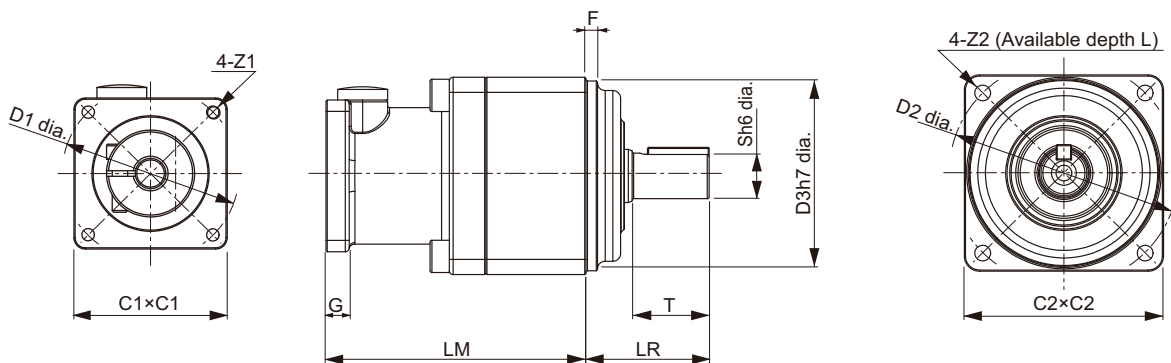

Dimensions [mm]											Model	
Z1	Z2	AT *	L	Key				Tap				
				QK	b	h	t1	m	l			
M4	M5	M4	12	16	4	4	2.5	M5	10	R88G-VRXF05B100CJ	1/5	50 W
M4	M5	M4	12	16	4	4	2.5	M5	10	R88G-VRXF09B100CJ	1/9	
M4	M5	M4	12	16	4	4	2.5	M5	10	R88G-VRXF15B100CJ	1/15	
M4	M5	M4	12	16	4	4	2.5	M5	10	R88G-VRXF25B100CJ	1/25	
M4	M5	M4	12	16	4	4	2.5	M5	10	R88G-VRXF05B100CJ	1/5	100 W
M4	M5	M4	12	16	4	4	2.5	M5	10	R88G-VRXF09B100CJ	1/9	
M4	M5	M4	12	16	4	4	2.5	M5	10	R88G-VRXF15B100CJ	1/15	
M4	M5	M4	12	16	4	4	2.5	M5	10	R88G-VRXF25B100CJ	1/25	
M4	M5	M4	12	16	4	4	2.5	M5	10	R88G-VRXF05B200CJ	1/5	200 W
M4	M6	M5	20	22	6	6	3.5	M6	12	R88G-VRXF09C200CJ	1/9	
M4	M6	M5	20	22	6	6	3.5	M6	12	R88G-VRXF15C200CJ	1/15	
M4	M6	M5	20	22	6	6	3.5	M6	12	R88G-VRXF25C200CJ	1/25	
M4	M6	M5	20	22	6	6	3.5	M6	12	R88G-VRXF05C400CJ	1/5	400 W
M4	M6	M5	20	22	6	6	3.5	M6	12	R88G-VRXF09C400CJ	1/9	
M4	M6	M5	20	22	6	6	3.5	M6	12	R88G-VRXF15C400CJ	1/15	
M4	M6	M5	20	22	6	6	3.5	M6	12	R88G-VRXF25C400CJ	1/25	
M5	M6	M6	20	22	6	6	3.5	M6	12	R88G-VRXF05C750CJ	1/5	750 W (200 V)
M5	M8	M6	20	30	8	7	4	M8	16	R88G-VRXF09D750CJ	1/9	
M5	M8	M6	20	30	8	7	4	M8	16	R88G-VRXF15D750CJ	1/15	
M5	M8	M6	20	30	8	7	4	M8	16	R88G-VRXF25D750CJ	1/25	

\* Indicates set bolt.

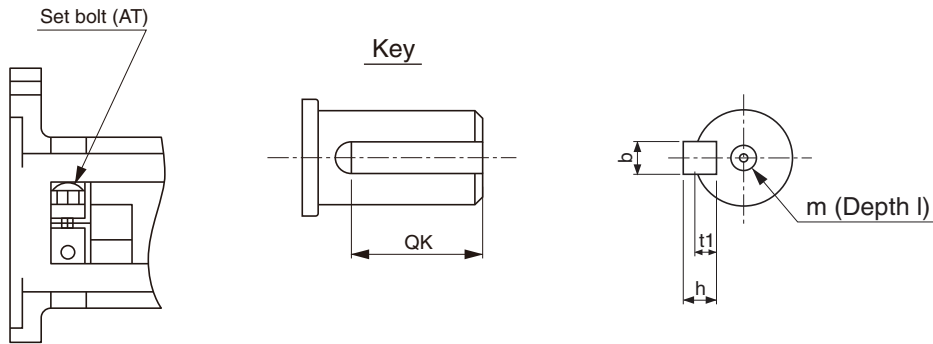

# AC Servomotor/Drive G5-series

## Related Manuals

Please read the relevant manuals of G5-Series

English Cat. No.	Japanese Cat. No.	Type	Name
I571	SBCE-357	R88D-KT/R88M-K	G5-SERIES AC SERVOMOTOR AND SERVO DRIVE USER'S MANUAL
I572	SBCE-358	R88D-KN□-ML2/R88M-K	G5-SERIES MECHATROLINK-II Communications AC SERVOMOTOR AND SERVO DRIVE USER'S MANUAL
I576	SBCE-365	R88D-KN□-ECT/R88M-K	G5-SERIES EtherCAT Communications AC SERVOMOTOR AND SERVO DRIVE USER'S MANUAL
I577	SBCE-366	E88D-KN□-ECT-L/R88L-EC	G5-SERIES EtherCAT Communications Linear Motor Type LINEARMOTOR AND DRIVE USER'S MANUAL
W487	SBCE-359	CJ1W-NC□81/CJ1W-NC□82	CJ-series Position Control Unit Operation Manual
W446	SBCA-337	CXONE-AL□□C-V□/-AL□□D-V□	CX-Programmer Operation Manual
W453	SBCE-375	CXONE-□□□□C-V□/□□□□D-V□	CX-Drive OPERATION MANUAL
W504	SBCA-470	SYSMAC-SE2□□□	Sysmac Studio Version 1 Operation Manual

# Terms and Conditions Agreement

## **Read and understand this catalog.**

Please read and understand this catalog before purchasing the products. Please consult your OMRON representative if you have any questions or comments.

## **Warranties.**

- (a) Exclusive Warranty. Omron's exclusive warranty is that the Products will be free from defects in materials and workmanship for a period of twelve months from the date of sale by Omron (or such other period expressed in writing by Omron). Omron disclaims all other warranties, express or implied.
- (b) Limitations. OMRON MAKES NO WARRANTY OR REPRESENTATION, EXPRESS OR IMPLIED, ABOUT NON-INFRINGEMENT, MERCHANTABILITY OR FITNESS FOR A PARTICULAR PURPOSE OF THE PRODUCTS. BUYER ACKNOWLEDGES THAT IT ALONE HAS DETERMINED THAT THE PRODUCTS WILL SUITABLY MEET THE REQUIREMENTS OF THEIR INTENDED USE.

Omron further disclaims all warranties and responsibility of any type for claims or expenses based on infringement by the Products or otherwise of any intellectual property right. (c) Buyer Remedy. Omron's sole obligation hereunder shall be, at Omron's election, to (i) replace (in the form originally shipped with Buyer responsible for labor charges for removal or replacement thereof) the non-complying Product, (ii) repair the non-complying Product, or (iii) repay or credit Buyer an amount equal to the purchase price of the non-complying Product; provided that in no event shall Omron be responsible for warranty, repair, indemnity or any other claims or expenses regarding the Products unless Omron's analysis confirms that the Products were properly handled, stored, installed and maintained and not subject to contamination, abuse, misuse or inappropriate modification. Return of any Products by Buyer must be approved in writing by Omron before shipment. Omron Companies shall not be liable for the suitability or unsuitability or the results from the use of Products in combination with any electrical or electronic components, circuits, system assemblies or any other materials or substances or environments. Any advice, recommendations or information given orally or in writing, are not to be construed as an amendment or addition to the above warranty.

See <http://www.omron.com/global/> or contact your Omron representative for published information.

## **Limitation on Liability; Etc.**

OMRON COMPANIES SHALL NOT BE LIABLE FOR SPECIAL, INDIRECT, INCIDENTAL, OR CONSEQUENTIAL DAMAGES, LOSS OF PROFITS OR PRODUCTION OR COMMERCIAL LOSS IN ANY WAY CONNECTED WITH THE PRODUCTS, WHETHER SUCH CLAIM IS BASED IN CONTRACT, WARRANTY, NEGLIGENCE OR STRICT LIABILITY.

Further, in no event shall liability of Omron Companies exceed the individual price of the Product on which liability is asserted.

## **Suitability of Use.**

Omron Companies shall not be responsible for conformity with any standards, codes or regulations which apply to the combination of the Product in the Buyer's application or use of the Product. At Buyer's request, Omron will provide applicable third party certification documents identifying ratings and limitations of use which apply to the Product. This information by itself is not sufficient for a complete determination of the suitability of the Product in combination with the end product, machine, system, or other application or use. Buyer shall be solely responsible for determining appropriateness of the particular Product with respect to Buyer's application, product or system. Buyer shall take application responsibility in all cases.

NEVER USE THE PRODUCT FOR AN APPLICATION INVOLVING SERIOUS RISK TO LIFE OR PROPERTY OR IN LARGE QUANTITIES WITHOUT ENSURING THAT THE SYSTEM AS A WHOLE HAS BEEN DESIGNED TO ADDRESS THE RISKS, AND THAT THE OMRON PRODUCT(S) IS PROPERLY RATED AND INSTALLED FOR THE INTENDED USE WITHIN THE OVERALL EQUIPMENT OR SYSTEM.

## **Programmable Products.**

Omron Companies shall not be responsible for the user's programming of a programmable Product, or any consequence thereof.

## **Performance Data.**

Data presented in Omron Company websites, catalogs and other materials is provided as a guide for the user in determining suitability and does not constitute a warranty. It may represent the result of Omron's test conditions, and the user must correlate it to actual application requirements. Actual performance is subject to the Omron's Warranty and Limitations of Liability.

## **Change in Specifications.**

Product specifications and accessories may be changed at any time based on improvements and other reasons. It is our practice to change part numbers when published ratings or features are changed, or when significant construction changes are made. However, some specifications of the Product may be changed without any notice. When in doubt, special part numbers may be assigned to fix or establish key specifications for your application. Please consult with your Omron's representative at any time to confirm actual specifications of purchased Product.

## **Errors and Omissions.**

Information presented by Omron Companies has been checked and is believed to be accurate; however, no responsibility is assumed for clerical, typographical or proofreading errors or omissions.

**Note: Do not use this document to operate the Unit.**

**OMRON Corporation Industrial Automation Company**  
Kyoto, JAPAN

**Contact: [www.ia.omron.com](http://www.ia.omron.com)**

**Regional Headquarters**

**OMRON EUROPE B.V.**

Wegalaan 67-69, 2132 JD Hoofddorp  
The Netherlands  
Tel: (31)2356-81-300/Fax: (31)2356-81-388

**OMRON ELECTRONICS LLC**

2895 Greenspoint Parkway, Suite 200  
Hoffman Estates, IL 60169 U.S.A.  
Tel: (1) 847-843-7900/Fax: (1) 847-843-7787

**OMRON ASIA PACIFIC PTE. LTD.**

No. 438A Alexandra Road # 05-05/08 (Lobby 2),  
Alexandra Technopark,  
Singapore 119967  
Tel: (65) 6835-3011/Fax: (65) 6835-2711

**OMRON (CHINA) CO., LTD.**

Room 2211, Bank of China Tower,  
200 Yin Cheng Zhong Road,  
PuDong New Area, Shanghai, 200120, China  
Tel: (86) 21-5037-2222/Fax: (86) 21-5037-2200

**Authorized Distributor:**

© OMRON Corporation 2009-2021 All Rights Reserved.  
In the interest of product improvement,  
specifications are subject to change without notice.

**CSM\_9\_13**

**Cat. No. I816-E1-08**

0721 (1109)