

ARUSH SWITCHGEARS

1801, 2nd Floor Bhagirath Palace, Delhi
9312211087/9811514724
enquiry@arushswitchgears.com
www.arushswitchgears.com

Numerous Brands
One Supplier

ARUSH



At *Arush Switchgears*, it is our always our constant endeavour to help our esteemed customers get the best on most competitive market prices.

Our strong alliance with the broad-list of brands helps us to always offer an extensive range of items, new product introductions from latest technologies as soon as they are available in the market. There are new products that are introduced on regular basis, from over a ocean of brands.

We'd really appreciate if you can share your product requirements for following brands & categories to get the best quotes from us.

Our Range

Automation & Control Gears	Lighting
Batteries	Pneumatics
Cables & Wires	Power Supplies
Connectors	Relays
Displays & Optoelectronics	ESD Control & Clean Room
Electricals	Sockets & Circuit Breakers
Enclosure & Storage	Switches
Fuses	Test & Measurement
HVAC, Fan & Thermal Management	Tools

Our Top Brands





Short Form Sensors

SUNX – Sensors by Panasonic Electric Works

A new performance class of innovative sensor technology

The variety and complexity of the tasks in automation and the increasing need for quality management have resulted in more and more specialized demands being placed on modern sensors. The decisive criteria here are maximum accuracy and reliability. In addition, factors such as ultraminiature design, flexible installation options and model diversity are becoming increasingly important.

Panasonic Electric Works' innovative sensor technology takes these requirements into account.

An interesting and extensive range of sensor products is being offered under the **SUNX** name – new sensor generations are being produced by the consistent application of state-of-the-art technology. The characteristic features of these sensors include intelligence, multifunctionality and miniature design.

The delivery program: Innovative and extensive.

Besides through-beam and retroreflective types, reflective sensors and optical fiber photoelectric sensors, we also offer laser and eddy current analog sensors that provide precise measurement results even in the most complicated of applications.

Our delivery program also includes safety sensors, photoelectric sensors for special applications, inductive proximity switches and miniature pressure sensors for relative or differential pressure measurement, and ionizers for Electro Static Discharge applications.

Quality management and product safety.

Quality, from design to production to customer service, has always been and will continue to be part of the Panasonic corporate philosophy. Strict quality guidelines, with ISO9001 and ISO9002 certification, ensure that our customers are also clear about this quality requirement. Since January 1, 1996, all sensors sold within Europe have carried the CE mark.

Service has priority.

We are constantly striving to optimize our service sector to enable us to react quickly to customer requests. Whether you have specific application requests or you simply want technical information, we are always ready to advise and assist you; you only have to call.

Our current delivery program is assembled for you in this sensor overview. Besides the most important technical data, you will find numerous illustrations of possible applications.

Of course, detailed data sheets are available on our homepage www.panasonic-electric-works.com. Our product managers, sales and application engineers will be happy to advise you.

Contents

	Page		Page
Fiber Optic Sensors		Pressure & Flow Sensors	
FX-100	4	FM-200	92
FX-301	6	DP-100	94
FX-311	8	DPH-100/DPC-100	96
FX500	9	DP2	98
FX-CH2	12	DP4	100
Fiber Sensors Communication Units		DP5/DPH	102
SC-GU1-485	14	DP-M	104
Optical Fiber Heads	16	CC-Link Solutions	
Standard Fibers	19	CC Link	105
Sensors for Semiconductors / FPD Industry		Inductive Proximity Sensors	
FD-L40	33	GX-F/H	107
FT/FD-V	34	GX5	109
EX-F70/F60	35	Measurement Sensors	
FR-KV1	36	GP-X	111
Fiber Heads		LM-10	112
FD-F705	37	HL-C1	114
FT-F902	38	HL-C135C-BK10, HL-C1C-M-WL	116
Laser Sensors		HL-C2	117
M18-L	39	HL-T1	120
LC-100	41	Ionizers / Electrostatic Sensors	
LC-120	43	ER-F	121
EX-L200	45	ER-TF	123
LS	47	ER-VW	125
Mark Sensors		ER-V	127
LX-100	49	EC-G	128
Photoelectric Sensors		EF-S1	129
CX-400	51		
NX5	55		
CY	57		
M18	59		
EX-10	60		
EX-20	62		
EX-30	64		
PM	66		
PM2	70		
NA1-11	72		
NA1PK	74		
Trigonometric Sensors			
EQ-500	76		
EQ-30	78		
MQ-W	79		
Safety Sensors			
ST4	80		
SF2B	82		
SF4B<V2>	83		
SF4C	85		
SD3-A1	89		
SF-C10	91		

FX-100



FX-100

Excellent price/performance ratio

Features

Easy to read

The digital dual-display allows you to check both the threshold value and incident light intensity at the same time, and it also makes the procedures for setting the various values much easier.

Multipurpose, M8 connector type

The connectors used are commercially-available M8 connectors, so that processing costs and lead time required for carrying out processing after purchase of the sensors can be greatly reduced.

Designed in a 3-layer structure to accommodate basic settings through to advanced settings.

Setting details are divided into three levels for clearer operation, so that setting for normal operation are made in 'RUN mode', basic settings are made in 'SET mode', and advanced functions are set in 'PRO mode'. This makes setting operations much easier to understand and carry out.

Typical Applications

Wafer detection FD-WKZ + FX 10□

Detects wafer carrier cases through vacuum chamber's view port.

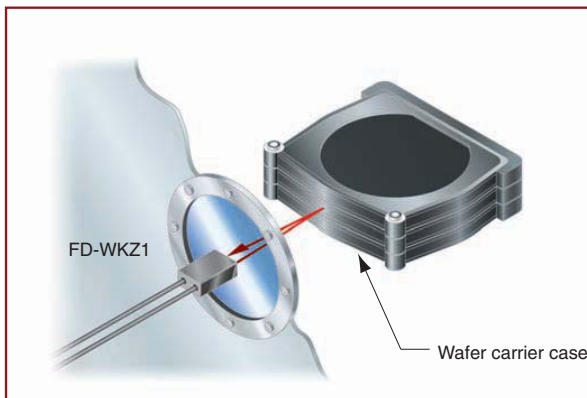

Wafer detection FT-L80Y + FX10□

Sensing possible in corrosive environment. Lenses at the ends of the fiber heads expand the sensing range.

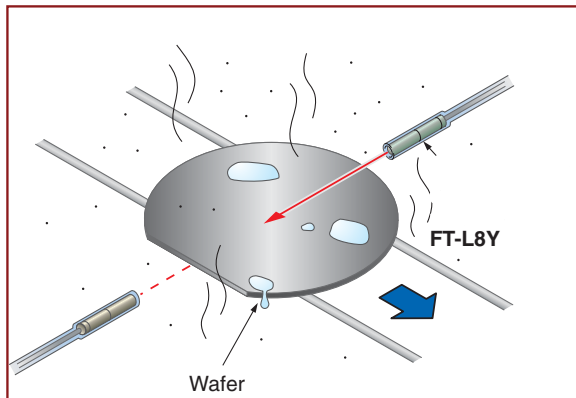

Detection of break / crack of glass

FV-SV2 + FX10□

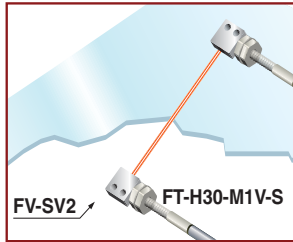

Detection over long ranges

FT-LE1 + FX10□

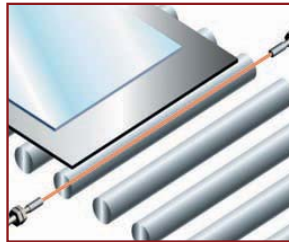

Detection of glass substrate in vacuum chamber

FD-H30-KZ1V + FX10□

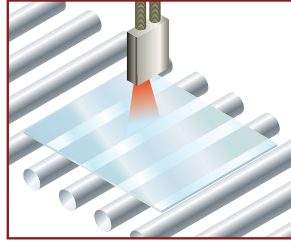

Detection of glass substrate on robot hand

FD-H30-L32V + FX10□

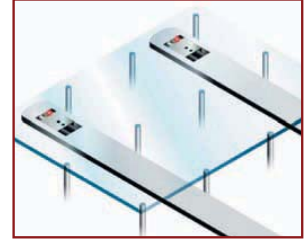

Technical Specifications

Model no.	Type	Standard type		Long sensing range type				
		NPN output	FX-101 (-Z) (Note 2)	Cable set	FX-101-CC2	FX-102 (-Z) (Note 2)	Cable set	FX-102-CC2
		PNP output	FX-101P (-Z) (Note 2)	FX-101P-CC2	FX-102P (-Z) (Note 2)	FX-102P-CC2		
Supply voltage	12 to 24VDC±10%, Ripple P-P 10% or less							
Power consumption	Normal operation: 720mW or less (Current consumption 30mA or less at 24V supply voltage) ECO mode: 600mW or less (Current consumption 25mA or less at 24V supply voltage)							
Output	<NPN output type> NPN open-collector transistor	<PNP output type> PNP open-collector transistor						
Output operation	Selectable either Light-ON or Dark-ON, at SET mode							
Short-circuit protection	Incorporated							
Response time	Emission frequency 0: 250µs or less Emission frequency 1: 450µs or less Emission frequency 2: 500µs or less Emission frequency 3: 600µs or less	Emission frequency 1: 2.5ms or less Emission frequency 2: 2.8ms or less Emission frequency 3: 3.2ms or less Emission frequency 4: 5.0ms or less						
Sensitivity setting	2-level teaching/Limit teaching/Full-auto teaching							
Digital display	4 digit green + 4 digit red LCD display							
Timer function	ON-delay/OFF-delay timer, switchable either effective or ineffective. [Timer period: 1ms, 5ms, 10ms, 20ms, 40ms, 50ms, 100ms, 500ms, 1000ms]							
Interference prevention function	Incorporated Selectable emission frequency method (Note 1) (Functions at emission frequency 1, 2 or 3)	Incorporated Selectable emission frequency method (Note 1) (Functions at emission frequency 1, 2, 3 or 4)						
Ambient temperature	-10 to +55°C (if 4 to 7 units are mounted close together: -10 to +50°C; if 8 to 16 units are mounted close together: -10 to +45°C (no dew condensation or icing allowed); Storage: -20 to +70°C							
Emitting element (modulated)	Red LED (Peak emission wavelength : 632nm)							
Material	Enclosure: polycarbonate; key switch: polycarbonate; fiber lock lever: PBT							
Connecting method	Connector (Note 2)							
Cable extension	Extension up to total 100m is possible with 0.3mm ² , or more, cable.							
Weight	Net weight: 15g approx. Gross weight: 35g approx.	Net weight: 15g approx. Gross weight: 75g approx.	Net weight: 15g approx. Gross weight: 35g approx.	Net weight: 15g approx. Gross weight: 75g approx.				
Accessory	—	CN-14A-C2 (connector attached cable, 2m long): 1pc	—	CN-14A-C2 (connector attached cable, 2m long): 1pc				

- Notes:** 1) When using the interference prevention function, set the emission frequencies for the amplifiers to be covered by the interference prevention function to different frequency values. However, the interference prevention function does not operate at emission frequency 0 (factory default setting) for the FX-101(P)(-Z)/FX-101(P)-CC2.
2) Connector attached cable CN-14A-C2 is not attached to the models that have no '-CC2' at the end of the model names.
Make sure to use the optional cable with connector CN-14A-CM.
Model n's. having the suffix '-Z' are M8 plug-in connector type. Make sure to use the optional M8 plug-in connector cable, UZZ808xx.

FX-301



FX-301

Enhanced functions and performance but still easy to use

Features

FX-301(P) (red LED type) version upgrade

We improved the standard model by enhancing its sensing stability and equipping it with handy functions such as the light-emitting amount selection function. This makes using a fiber sensor easier than ever while conserving the superior operability of the conventional model.

Super high speed response of 35 μ s

The new FX-301(P)-HS model is the digital type fiber sensor realizing a super high speed response of 35 μ s rendering it capable of sensing minute objects moving at high speeds. At 65 μ s, the standard FX-301(P) model (H-SP mode) realizes twice the speed of the conventional model.

Stable sensing over long and short periods

In addition to a *four-chemical emitting element* which suppresses changes in the light-emitting element over time so that a stable level of light emission can be maintained over long periods, a new *APC (Auto Power Control) circuit* has also been adopted. Because fluctuations over short periods of time have also been suppressed, stable sensing is possible very quickly once the power is turned back on after setup changes.

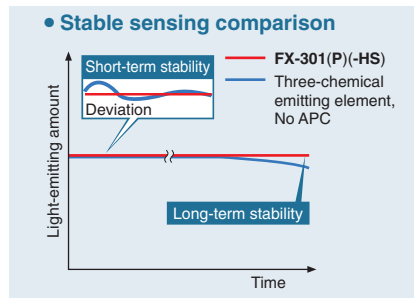

Sensing range has been greatly increased

All models use a *double coupling lens* that enables a much wider sensing range and maximization in the light emission efficiency. Sensing ranges with small diameter fibers and ultra small diameter fibers, which have become very popular due to the miniaturization of chip components, have been increased by 50% over previous values achieved with other amplifiers.

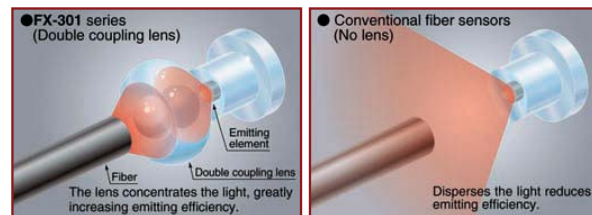

Typical Applications

Red LED type – FX-301(P)(-HS)

Workpiece detection

This standard type of FX-301(P)(-HS) using red light has a four-chemical emitting element for stable sensing over long periods.

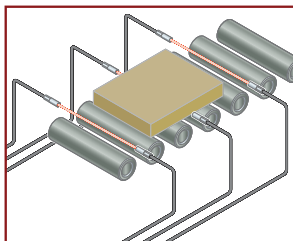

Blue LED type – FX-301B(P)

Sensing translucent stickers

The blue LED type greatly reduces the damping rate, making it ideal for delicate sensing.



Green LED type – FX-301G(P)

Sensing register marks

The green LED type greatly reduces the damping rate, making it ideal for delicate sensing.

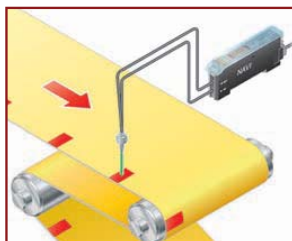

Infrared LED type – FX-301H(P)

Sensing film meandering

Infrared LED type is ideal for sensing environments with light restrictions, such as places where light-sensitive film is being handled.



Object sensing during the painting process

Due to a sensing range of 19.5m (FX-301 long range mode) and a 10m fiber length, it can be lead through explosive atmospheres freely.



Engine block passage confirmation

FD-WKZ1 has realized a sensing range of 480mm (FX-301 long range mode). In addition, due to its powerful beam, it can even work in adverse environments such as in areas prone to dust.

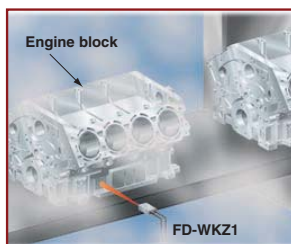

Wire breakage detection

The blue LED type greatly reduces the damping rate, making it ideal for delicate sensing.

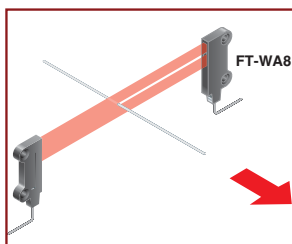

Technical Specifications

Type	Standard type ¹⁾	High speed	
Model. no.	NPN output	FX-301□	FX-301-HS
	PNP output	FX-301□P	FX-301P-HS
Sensing range (Red LED type)	Thru-beam type (FT-B8): 1100mm (LONG), 530mm (STD), 400mm (FAST), 200mm (H-SP), 180mm (S-D)	Thru-beam type (FT-B8): 1100mm (LONG), 530mm (STD), 400mm(FAST), 160mm (H-SP), 180mm (S-D)	
	Reflective type (FD-B8): 480mm (LONG), 220mm (STD), 160mm (FAST), 85mm (H-SP), 75mm (S-D)	Reflective type (FD-B8): 480mm (LONG), 220mm (STD), 160mm (FAST), 60mm (H-SP), 75mm (S-D)	
Supply voltage	12 to 24VDC ± 10%		
Output	NPN output type: NPN open-collector transistor PNP output type: PNP open-collector transistor		
Output operation	Selectable either Light-ON or Dark-ON, with jog switch		
Response time	65μs or less [H-SP (Red LED type only)]; 150μs or less (FAST); 250μs or less [STD/S-D (Red LED type only)]; 2ms or less (LONG) selectable with jog switch	35μs or less (H-SP); 150μs or less (FAST); 250μs or less (STD/S-D); 2ms or less (LONG) selectable with jog switch	

Type	Standard type ¹⁾	High speed	
Model. no.	NPN output	FX-301□	FX-301-HS
	PNP output	FX-301□P	FX-301P-HS
Sensitivity setting	2-level teaching / Limit teaching / Manual adjustment / Full-auto teaching		
Digital display	4-digit red LED display		
Automatic interference prevention function	Incorporated [(Up to 4 sets of fiber heads can be mounted close together.) (However, H-SP mode is 2 sets.)]		
Ambient temperature	-10 to +55°C (If 4 to 7 units are connected in cascade: -10 to +50°C, if 8 to 16 units are connected in cascade: -10 to +45°C)		
Emitting element (modulated)	FX-301(P): Red LED, FX-301B(P): Blue LED, FX-301G(P): Green LED, FX-301H(P): Infrared LED	Red LED	
Dimensions (W×H×D)	10×30.5×64.5mm		

Note: 1) The cable for amplifier connection is not supplied as an accessory. Make sure to use the optional quick-connection cable given below.
Main cable (3-core): CN-73-C1 (cable length 1m), CN-73-C2 (cable length 2m), CN-73-C5 (cable length 5m)
Sub cable (1-core): CN-71-C1 (cable length 1m), CN-71-C2 (cable length 2m), CN-71-C5 (cable length 5m)

FX-311

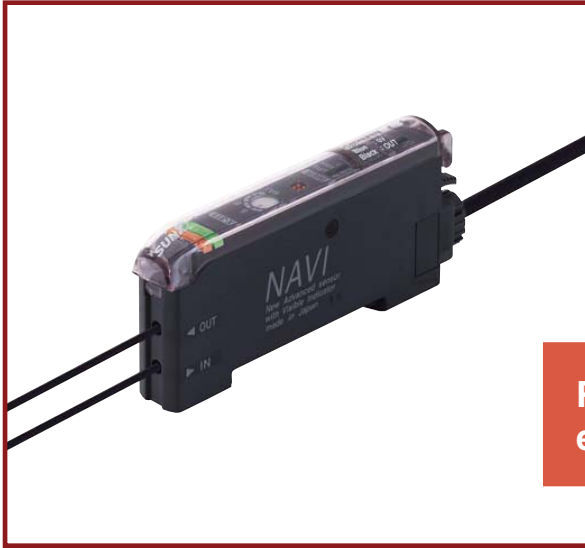

FX-311

Remarkably easy to use, yet employs the latest in technology

Features

12-turn potentiometer with visible indicator

12-turn potentiometer has been incorporated for fine adjustments. It enables very fine differences to be detected. Since the potentiometer is illuminated, you can even make adjustments easily in dark areas.

Three light source types (red, green, blue) are made available for expanding applications

Rapid blinking 'assist function' eases adjustment for optimum sensitivity.

Typical Applications

Detecting transparent PET bottles

The green LED type is ideal for stably sensing objects such as transparent bottles which yield only small amounts of light fluctuation.

Register mark detection

The blue LED type can accurately sense yellow marks on white backgrounds that are difficult to sense using the red LED type.

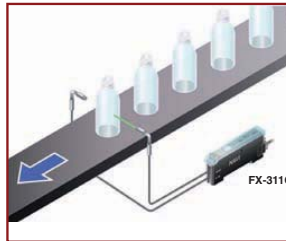

Technical Specifications

Model no.	NPN output	FX-311
	PNP output	FX-311P
Supply voltage	12 to 24VDC ± 10%, Ripple P-P 10% or less	
Power consumption	840mW or less (Current consumption 35mA or less at 24V supply voltage)	
Output	<NPN output type> NPN open-collector transistor (FX-311) <PNP output type> PNP open-collector transistor (FX-311P)	
Output operation	Selectable either Light-ON or Dark-ON, with selection switch	
Short-circuit protection	Incorporated	
Response time	250µs or less (STD / S-D), 2ms or less (LONG) selectable with selection switch	
Operation indicator	Orange LED (lights up when the output is ON)	
Timer function	Incorporated with OFF-delay timer, selectable either effective (approx. 10ms or 40ms) or ineffective	
Automatic interference prevention function	Incorporated (Up to 4 sets of fiber heads can be mounted closely.) (Note 1)	
Ambient temperature	-10 to +55°C (if 4 to 7 units are mounted close together: -10 to +50°C; if 8 to 16 units are mounted close together: -10 to +45°C (no dew condensation or icing allowed); Storage: -20 to +70°C	
Emitting element (modulated)	Red LED	
Material	Enclosure: Heat-resistant ABS, Case cover: Polycarbonate	
Connecting method	Connector (Note 2)	
Cable extension	Extension up to total 100m is possible with 0.3mm ² , or more, cable	
Weight	15g approx.	

Notes: 1) When the power supply is switched on, the emission timing are automatically set for interference prevention.
2) The cable for amplifier connection is not supplied as an accessory. Make sure to use the optional quick-connection cable given below.
Main cable (3-core): CN-73-C1 (cable length 1m), CN-73-C2 (cable length 2m), CN-73-C5 (cable length 5m).
Sub cable (1-core): CN-71-C1 (cable length 1m), CN-71-C2 (cable length 2m), CN-71-C5 (cable length 5m).



FX-500

Fiber amplifier at the industry's leading edge

Features

A different stability

When used with the super quality fiber as a set, the incident light intensity variation among units is decreased to only 1/4 of that of conventional models.

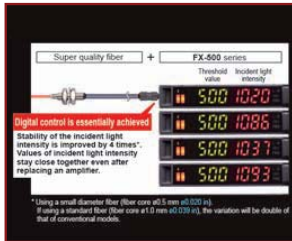

High performance

FX-500 with its ultra high response time improves productivity.

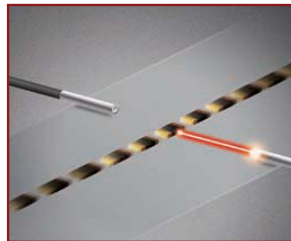

HYPER mode incorporated

FX-500 in combination with the small diameter fiber can handle challenging detections over a super long sensing range.



A different accuracy!

FX-500 with its accurate detection catches fractional difference in light intensity, fulfilling high precision and low-hysteresis applications.

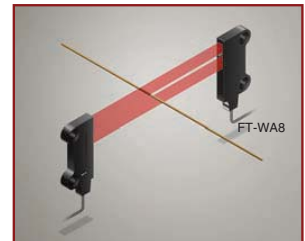

Typical Applications

Counting of IC pins

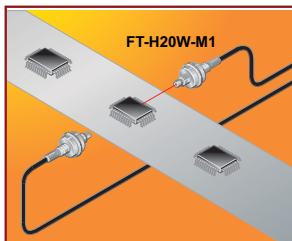

Check crimping

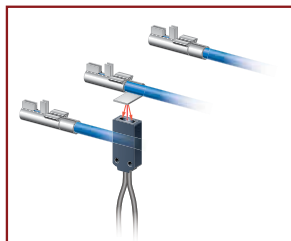

Detection of glass substrate



FX500 Technical Specifications

	Standard type	Two outputs type
NPN output PNP output	FX-501 FX-501P	FX-502 FX-502P
Type of amplifier	Digital	
Timer function	Adjustable: 0.1ms to 999.9ms in 0.1ms steps, 1 to 9999ms in 1 ms steps, 1 to 32s in 1s steps	
Interference prevention function	Auto interference prevention function for up to 12 units and selectable emission frequency method	
Sensing range	Depends on fiber type used	
Response time	25μs/60μs/250μs/2ms/4ms/24ms or less	
Output transistor	Max. 100mA	
Emitting element	Red LED (Peak emission wavelength: 643nm)	
Material	Enclosure: ABS; switch TPEE	
Rated current consumption	Normal operation: 40mA or less at 24V supply voltage Eco mode: 30mA or less at 24V supply voltage	
Protection	IP40	
Physical size (HxWxL)	34x10x75mm	
Connection method	Connector attached cable (note)	
Operating voltage	12-24V DC (±10%)	
Usable ambient temp.	-10°C to +55°C	
Weight approx.	70g	

Note: The cable for amplifier connection is not supplied as an accessor. Make sure to use the optional quick-connection cable given below.

For FX-501(P)

Main cable (3-core): CN-73-C1 (1m), CN-73-C2 (2m), CN-73-C5 (5m)

Sub cable (1-core): CN-71-C1 (1m), CN-71-C2 (2m), CN-71-C5 (5m)

For FX-502(P)

Main cable (4-core): CN-74-C1 (1m), CN-74-C2 (2m), CN-74-C5 (5m)

Sub cable (2-core): CN-72-C1 (1m), CN-72-C2 (2m), CN-72-C5 (5m)

A quality that surpassed standard fiber

Stable emission intensity ±10

Variation in emission intensity of the fiber core is controlled down to less than ±10%, achieving a stable detection.



Integrated high-precision plug

The centering precision of the fiber core attached to the inserting plug is doubled. As the insertion precision is increased, the variation among units can be greatly suppressed.



More flexible!

Bending radius = R4mm
[Previous was R25mm]



More bendable!

Bending durability = 10 million times
[Previous was 1,000 times]



List of Super Quality Fibers for FX500*

Thru-beam type (one pair set)



Type	Shape of fiber head (mm)	Sensing range (mm)		Dia of beam axis (mm)	Fiber cable length	Bending radius	Ambient temperature	Model no.	
		HYPR (red) : STD (purple) : H-SP (yellow)	U-LG : LONG : FAST						
Threaded	M4		HYPR: 3,600 STD: 1,200 H-SP: 190	U-LG: 2,200 LONG: 1,700 FAST: 530	2m	R4 Allowable bending radius	-55 to +80°C	FT-40	
	M3		HYPR: 1,350 STD: 400 H-SP: 75	U-LG: 810 LONG: 650 FAST: 210				FT-30	
Cylindrical	ø3		HYPR: 3,600 STD: 1,200 H-SP: 190	U-LG: 2,200 LONG: 1,700 FAST: 530				ø1	FT-S30
	ø1.5		HYPR: 1,350 STD: 400 H-SP: 75	U-LG: 810 LONG: 650 FAST: 210				ø0.5	FT-S20

Reflective type



Type	Shape of fiber head (mm)	Sensing range (mm)		Fiber cable length	Bending radius	Ambient temperature	Model no.	
		HYPR (red) : STD (purple) : H-SP (yellow)	U-LG : LONG : FAST					
Threaded	M6		HYPR: 1,550 STD: 520 H-SP: 90	U-LG: 900 LONG: 740 FAST: 260	2m	R4 Allowable bending radius	-55 to +80°C	FD-60
	M4		HYPR: 600 STD: 160 H-SP: 25	U-LG: 330 LONG: 250 FAST: 80				FD-40
	M3		HYPR: 600 STD: 160 H-SP: 25	U-LG: 330 LONG: 250 FAST: 80				FD-30
Cylindrical	ø3		HYPR: 600 STD: 160 H-SP: 25	U-LG: 330 LONG: 250 FAST: 80				ø1

*) All fibers presented on page 15-38 can be used with FX500 fiber amplifier, too. For sensing range and sensing diagrams, please ask your local dealer.



FX-CH2

External input unit for digital sensor

Features

Up to 16 sensors can be set/switched simultaneously by an external signal

Up to 16 digital fiber sensors can be set/switched simultaneously not by directly operating the sensors but from a PLC, a touch panel, a push button, or some other external signal generating device.

Simultaneous teaching

- Full-auto teaching
- Limit teaching '1'
- Limit teaching '+'
- 2-level teaching

Key lock setting

Even the enable/disable command for the key lock setting, a function designed to prevent operational mistakes, can be effectuated simultaneously from an external signal.

Batch loading and saving of bank settings

The bank settings for 3 previously set channels can be loaded and saved all together using an external signal.

Technical Specifications

Type	NPN input type	PNP input type
Model no.	FX-CH2	FX-CH2-P
Applicable sensor	FX-301(P) (Version upgrade), FX-305(P)	
Supply voltage	12 to 24VDC±10%	
Input	Low: 0 to +2VDC High: +5V to +VDC, or open	Low: 4V to +VDC High: 0 to +0.6VDC, or open
Power indicator	Green LED	
Transmission operation indicator	Green LED (lights up when loaded, and 2-level/limit teaching blinks lights up when saved, and full-auto teaching)	
Ambient temperature	-10 to +55°C (if 4 to 7 sensors are mounted close together: -10 to +50°C, if 8 to 16 sensors are mounted close together: -10 to +45°C)	
Dimensions	10×27×68.5mm	

Typical Application

Setup changes (external automatic teaching/ data bank switching)

Digital fiber settings can be changed using input from a touch screen or switch, so that production line setup changes can be carried out more easily.

External teaching

Full auto-teaching is recommended for teaching when the sensing object is changed without stopping the line.

Data bank switching

Settings such as output operations (L-ON/D-ON) and timer operations can be recorded in the digital fiber sensor's data bank, and switching can be carried out externally.

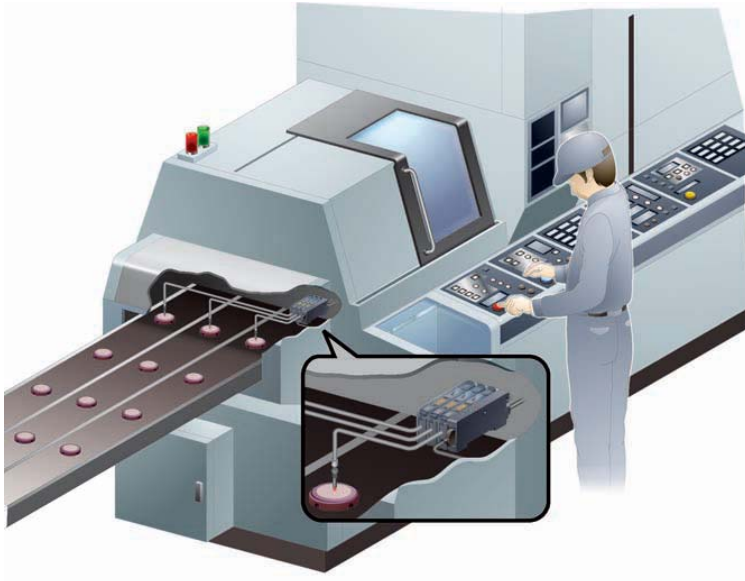

SC-GU1-485



SC-GU1-485

We now offer remote maintenance for digital sensors

Features

Function handy for startup and maintenance

Using a PLC or PC, this communication unit not only facilitates inputs (teaching, bank switching) to a digital fiber sensor [FX-301(P)/305(P)] but also received-light amount and output status verifications greatly enhance workability during startup and maintenance.

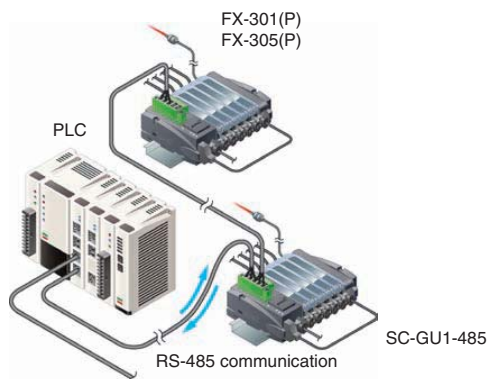

Series connection (RS485) of a maximum of 31 nodes is possible

A maximum of 31 nodes can be connected in series. This is ideal for flexible handling when the sensors are to be installed in scattered locations or when more sensors are added.

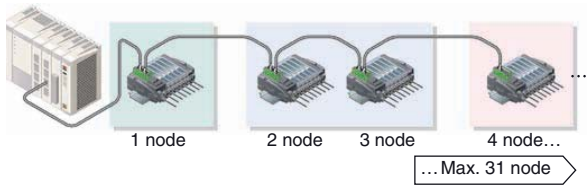

Technical Specifications

Type	Main Unit
Model no.	SC-GU1-485
Applicable sensor	FX-301 (P), FX-305 (P)
Supply voltage	24VDC±10% Ripple P-P10% or less
Ambient temperature	-10 to +55°C (if 4 to 7 sensors are connected: -10 to +50°C, If 8 to 16 sensors are mounted close together: -10 to +45°C) (No dew condensation or icing allowed), Storage: -20 to +70°C
Material	Enclosure: Heat-resistant ABS
Weight	35g approx. (10g approx. for SC-GU1-EU)

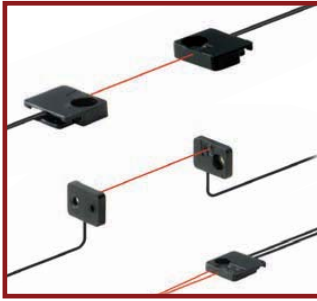

Sharp bending fiber

Now, an even greater variety of sharp bending fibers

FT/FD-W

Compact bending same as electrical wires

With the smallest bending radius being over R1mm and the coaxial types capable of highly accurate sensing (FD-WG4 and FD-WSG4) being over R2mm, this fiber can bend sharply like a cable to reduce wasted space.

All 24 models! Complete lineup!

13 thru-beam models and 11 reflective models are available for a total of 24 models. You are sure to find the sharp bending fiber that is best for you.

Does not break even at sharp bends

It does not break even at sharp bends. Furthermore, due to low loss in light intensity, there is almost no affect on the sensing range.



Fiber cable won't break, even when bent to this extent!

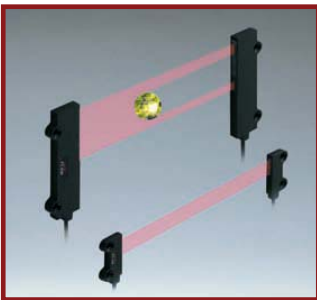

Wide beam fiber

Sensing possible across a wide area

FT-WA30/A30, FT-WA8/A8, FD-A15

Wide range

It has a wide sensing width of 11mm for FT-WA8/A8 and 32mm for FT-WA30/A30 enabling long distance sensing of objects as far as 3500mm (with FX-301 in LONG mode). Optimal for detecting unsteady objects or small objects.

Seal slit mask is available

A seal slit mask reduces the width and thereby the intensity of the emitting beam, which enables much smaller objects to be detected.

Space saving installation possible

FT-WA30/A30 and FT-WA8/A8 depth fibers boast a slim size of 20mm and 13.5mm respectively that enables mounting in even the narrowest of lines.

Checking ICs for burrs

Wide beam fiber enables accurate detection even if burrs fluctuate in size and position.

Heat-resistant M4 head reflective fiber

Heat-resistant fiber uses less setting-up space

OPTICAL FIBER HEADS

Optical Fiber Heads

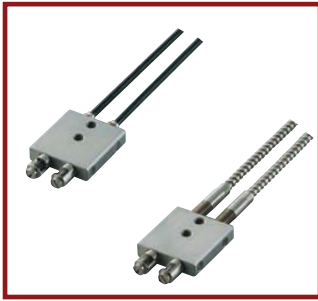

*Heat-resistant, fixed-focus reflective fiber
Glass substrate detection in high temperature
production line*

FD-H30-L32 FD-H18-L31

2 types to choose from to match your working environment

High precision detection

In addition to excellent heat resistance, these fibers have achieved a repeatability of 0.06mm for transparent glass substrates.

Extended detection range

Now available with full-range detection capabilities containing no dead zones (in both LONG and STD modes). Also, an extended detection distance of 15mm (in LONG mode) has been achieved, which even allows warping in glass substrates to be detected.

Glass substrate sensing

High temperature (300°C) production line glass substrate sensing possible. Accurately detects transparent glass substrates even at 300°C.

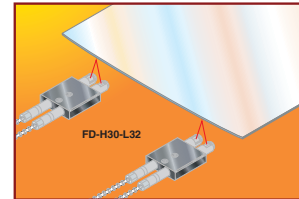

*Heat-resistant M4 head reflective fiber
Heat-resistant fiber requires less setup space*

FD-H20-21 FD-H35-20S

Heat-resistant fiber saves installation space

The fiber head has M4 screw threads allowing installation space savings when using many fibers.

High-precision positioning is possible

The 200°C heat-resistant fiber (FD-H20-21) uses a coaxial fiber that makes high-precision positioning possible.

Heat-resistant fiber with sleeve (FD-H35-20S)

The sleeve is useful for cases when the fiber head cannot be installed close to the sensing location.

Can be installed in narrow spaces

A flexible metal jacket sheath that allows cables to be routed easily has been adopted.



Sharp bending fiber
Now, an even greater variety of sharp bending fibers

FR-KZ21/KZ21E

Stable sensing of transparent objects is possible!

A unique optical system gives excellent performance in sensing transparent objects at close ranges.

Uses an exclusive reflector (RF-003) for stable sensing of transparent objects such as transparent sheets on transparent mounts and transparent tubes.

Ultra compact fiber head & compact reflector!

The fiber head size is ultra compact at W9.52×H5.22×D21mm (side sensing type: W9.52×H252×D5.2mm). The reflector is also a compact W10.62×H282×D10.1mm so that it is very space efficient.

Two types of fiber head for different installation directions

Two types of fiber head are available: a *Top* sensing type (FR-KZ21) and a *Side* sensing type (FR-KZ21E). Whichever type best suits the installation conditions can be selected.

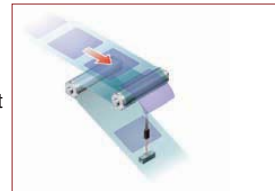

Narrow beam retroreflective type fiber
Ideal for sensing transparent objects!

FR-WKZ11

Compact head and long sensing range

This fiber has a compact head of W9.5×H5.2×D15mm. It is a retroreflective type with a polarizing filter that has a long sensing range of 3200mm.

Unaffected by surface reflection from transparent objects

FR-WKZ11 has a built-in polarizing filter in its tip, so that it is unaffected by surface reflection from transparent objects and specular objects directly in front of it.

Gives stable detection of transparent objects

Because it is a retroreflective type, light passes through transparent objects twice, so differences in the amount of light can be easily picked up and glass substrate and transparent films can be detected with good stability.



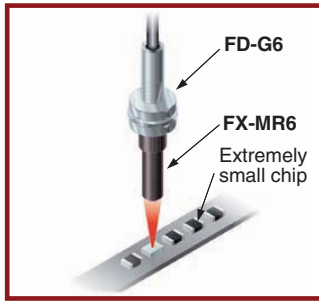

*Coaxial M3 head reflective fiber
High-precision & space saving*

FD-G6

Fiber allows installation space saving

The fiber head has M3 screw threads, allowing installation space saving when using many fibers.

High-precision positioning is possible

This coaxial fiber has the emitting fiber at the center and the receiving fiber around it. This fiber is ideal for high-precision positioning.

Allows sensing of very small objects

FX-MR6 and **FX-MR3** finest spot lenses can be attached making this fiber ideal for sensing very small objects e.g. the orientation of chips.



*Long sensing range rectangular head reflective fiber
Narrow field of view/long distance detection!*

FD-WKZ1

Compact fiber head

FD-WKZ1 has a compact head with dimensions of 9.2×5.2×15mm (W×H×D).

Narrow-view reflective type fiber allows for accurate aiming through narrow aperture obstruction

The beam spread of **FD-WKZ1** has been reduced to approximately 1/5 of that of conventional fiber, enabling detection through narrow apertures.

Long sensing range

Sensing can now be performed over distances of 480mm. Furthermore, the implementation of a powerful light beam allows the sensor to perform detection under difficult sensing conditions where high levels of dust and coarse particulates are present.

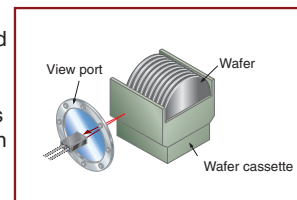

Optical Fibers for FX 100 Series

Thru-beam type (one pair set)



Fibers are listed in alphabetic order.

Model no.	Sensing range (mm) (Note 1)	
	Standard type FX-101□	Long sensing range type FX-102□
FT-A8	1500	3500 (Note 2)
FT-A30	3500 (Note 2)	3500 (Note 2)
FT-AFM2	280	720
FT-AFM2E	240	670
FT-B8	400	1,150
FT-E12	6	19
FT-E22	15	60
FT-FM2	300	800
FT-FM2S		
FT-FM2S4		
FT-FM10L	9300	15,000
FT-H13-FM2	250	700
FT-H20-J20-S (Note 3)	135	420
FT-H20-J30-S (Note 3)		
FT-H20-J50-S (Note 3)		
FT-H20-M1	210	540
FT-H20-VJ50-S (Note 3)	150	500
FT-H20-VJ80-S (Note 3)		
FT-H20W-M1	100	300
FT-H30-M1V-S (Note 4)	110	280
FT-H35-M2	170	490
FT-H35-M2S6		
FT-HL80Y	990	2340
FT-K8	1000	3000
FT-KV1	135	500
FT-KV8	1000	3000
FT-L80Y	1100	2600
FT-NFM2	130	280
FT-NFM2S		
FT-NFM2S4		
FT-P2	120	330
FT-P40	80	240
FT-P60	130	300
FT-P80	230	650
FT-P81X	260	800

Model no.	Sensing range (mm) (Note 1)	
	Standard type FX-101□	Long sensing range type FX-102□
FT-PS1	40	90
FT-R80	180	430
FT-SFM2	300	800
FT-SFM2L	760	2400
FT-SFM2SV2	180	470
FT-SNFM2	130	280
FT-T80	300	800
FT-V10	1000	2350
FT-V22	140	380
FT-V41	40	120
FT-V80Y	340	800
FT-W4	80	220
FT-W8	260	650
FT-WA8	1500	3500 (Note 2)
FT-WA30	3500 (Note 2)	3500 (Note 2)
FT-WKV8	700	2200
FT-WR80	215	570
FT-WR80L	430	1150
FT-WS3	150	600
FT-WS4	80	220
FT-WS8	260	650
FT-WS8L	600	1500
FT-WV42	30	80
FT-WZ4	230	670
FT-WZ4HB	80	230
FT-WZ7	330	1000
FT-WZ7HB	190	580
FT-WZ8	330	950
FT-WZ8E	700	2100
FT-WZ8H	1200	2800
FT-Z8	360	1000
FT-Z8E	800	1850
FT-Z8H	1400	3100
FT-Z802Y	520	3100

- Notes:**
- 1) Please take care that the sensing range of the free-cut type fiber may be reduced by 20% max. depending upon how the fiber is cut.
 - 2) The fiber cable length practically limits the sensing range to 3500mm long.
 - 3) Heat-resistant joint fibers and ordinary-temperature side fibers (FT-FM2) are sold as a set.
 - 4) Sold as a set comprising vacuum-resistant type fiber + photo-terminal (FV-BR1) + fiber at atmospheric side (FT-J8).

Optical Fibers for FX 100 Series

Retroreflective type



Fibers are listed in alphabetic order.

Model no.	Sensing range (mm) (Notes 1, 2)	
	Standard type FX-101□	Long sensing range type FX-102□
FR-KV1	15 to 200	15 to 360
FR-KZ21	200	200
FR-KZ21E	200	200
FR-WKZ11	100 to 550	100 to 830

Notes: 1) Please take care that the sensing range of the free-cut type fiber may be reduced by 20% max. depending upon how the fiber is cut.
The sensing range of **FR-WKZ11** is specified for the **RF-13**. The sensing range of **FR-KZ21**, **FR-KZ21E** and **FR-KV1** is specified for the attached reflector.
The sensing ranges when using in combination with the **FR-WKZ11** reflector (optional) are given in the below table.

Reflector \ Amplifier	FX-101□	FX-102□
FR-WKZ11 + RF-210	100 to 700	100 to 1100
FR-WKZ11 + RF-220	100 to 1300	100 to 2600
FR-WKZ11 + RF-230	100 to 2000	100 to 4000

- 2) The sensing range of **FR-WKZ11** is the possible setting range for the reflector or reflective tape. The fiber can detect an object less than 100mm away. However, note that if there are any white or highly-reflective surfaces near the fiber head, reflected incident light may affect the fiber head. If this occurs, adjust the threshold value of the amplifier unit before use.
The sensing range of **FR-KZ21(E)** is the possible setting range for the reflector. However, if setting the fiber to detect objects passing within 0 to 20mm from the fiber head, unstable detection may result.
The sensing range of **FR-KV1** is the possible setting range for the reflector. The fiber can detect an object less than 15mm away.

Reflective type



Fibers are in alphabetic order.

Model no.	Sensing range (mm) (Notes 1, 2)	
	Standard type FX-101□	Long sensing range type FX-102□
FD-A15	125	250
FD-AFM2	105	285
FD-AFM2E	85	245
FD-B8	170	440
FD-E12	3.5	13
FD-E22	16	45
FD-EG1	18	50
FD-EG2	10	30
FD-EG3	7	22
FD-EN500S1	1	4
FD-ENM1S1	15	48
FD-F4	Applicable pipe diameter: Outer dia. ø6 to ø26mm transparent pipe [PFA (fluorine resin) or equivalently transparent pipe, wall thickness 1mm]	
FD-F41	Applicable pipe diameter: Outer dia. ø6 to ø26mm transparent pipe [PVC (vinyl chloride), fluorine resin, polycarbonate, acrylic, glass, wall thickness 1 to 3mm]	
FD-F8Y	-	
FD-FM2	100	410
FD-FM2S	100	345
FD-FM2S4		
FD-G4	50	120

Model no.	Sensing range (mm) (Notes 1, 2)	
	Standard type FX-101□	Long sensing range type FX-102□
FD-G6	50	120
FD-G6X	45	160
FD-H13-FM2	100	280
FD-H18-L31	0 to 10	0 to 25
FD-H20-21	90	280
FD-H20-M1	120	300
FD-H30-KZ1V-S (Note 3)	25 to 80	10 to 220
FD-H30-L32	2 to 9	0 to 17
FD-H30-L32V-S (Note 3)	2.5 to 6.5	0 to 11
FD-H35-20S	85	200
FD-H35-M2	75	280
FD-H35-M2S6		
FD-L4	5 to 8 (Convergent point 6)	1 to 17 (Convergent point 6)
FD-L41	3 to 14 (Convergent point 8)	1.5 to 16 (Convergent point 8)
FD-L43	0 to 19	0 to 25
FD-L44	0 to 6	0 to 8
FD-L44S	0 to 4.5	0 to 5.5
FD-L45	0 to 40	0 to 50
FD-L46	16 to 30	12 to 50
FD-NFM2	35	100
FD-NFM2S		
FD-NFM2S4		
FD-P2	25	65

- Notes: 1) The standard sensing objects of the sensing ranges vary depending on the fibers.
2) Please take care that the sensing range of the free-cut type fiber may be reduced by 20% max. depending upon how the fiber is cut.
3) Sold as a set comprising vacuum-resistant type fiber + photo-terminal (**FV-BR1**) + fiber at atmospheric side (**FT-J8**).

Optical Fibers for FX 100 Series

Reflective type



Fibers are listed in alphabetic order.

Model no.	Sensing range (mm) (Notes 1, 2)	
	Standard type FX-101□	Long sensing range type FX-102□
FD-P40	8	30
FD-P50	45	150
FD-P60	45	150
FD-P80	90	200
FD-P81X	70	220
FD-R80	70	180
FD-S80	100	345
FD-SFM2SV2	30	90
FD-SNFM2	35	100
FD-T40	35	100
FD-T80	100	345
FD-V41	25	70
FD-W8	80	230
FD-W44	15	40

Model no.	Sensing range (mm) (Notes 1, 2)	
	Standard type FX-101□	Long sensing range type FX-102□
FD-WG4	28	75
FD-WKZ1	20 to 180	20 to 480
FD-WL41	7 to 12 (Convergent point 8)	6 to 13.5 (Convergent point 8)
FD-WL48	1 to 4.5	0.5 to 6.5
FD-WS8	80	230
FD-WSG4	28	75
FD-WT4	15	40
FD-WT8	80	230
FD-WV42	6	20
FD-WZ4	2 to 20	1 to 70
FD-WZ4HB		
FD-WZ7	1 to 55	160
FD-WZ7HB	1 to 60	0.5 to 180

Notes: 1) The standard sensing objects of the sensing ranges vary depending on the fibers.

2) Please take care that the sensing range of the free-cut type fiber may be reduced by 20% max. depending upon how the fiber is cut.

Optical Fibers for FX 300 Series

Thru-beam type (one pair set)



The FX-305 and FX-301(-HS) have different sensing modes.
 FX-305: H-SP, FAST, STD, STDF, LONG, U-LG (no S-D mode)
 FX-301(-HS): S-D, H-SP (Note 1), FAST, STD, LONG (no STDF or U-LG mode)

Type	Shape of fiber head (mm)	Sensing range (mm) (Note 1)	U-LG LONG STDF STD	FAST H-SP S-D	Min. sensing object (Note 3)	Fiber cable length Free-cut	Bending radius	Model no.
M4	Lens mountable	1600 1100 700 530	400 200 180	0.04mm opaque object	2m	R25mm	FT-B8	
	Lens mountable						FT-FM2	
	Sleeve 90mm ø1.48	1000 780 500 400	280 150 130	0.03mm opaque object	2m	Fiber R25mm Sleeve R10mm	FT-FM2S FT-FM2S4	
	Sleeve 40mm ø1.48							
	Lens mountable	750 570 350 290	200 90 100	0.03mm opaque object		R1mm	FT-W8	
	Lens mountable	900 650 400 320	230 100 110	0.04mm opaque object		R4mm Flexible	FT-P80	
	Lens mountable	900 650 380 320	230 100 110	0.05mm opaque object	1m	R10mm	FT-P81X	
	Lens mountable Tough flexible	550 400 250 190	140 70 80	0.04mm opaque object	2m	R4mm Flexible	FT-P60	
	Threaded type	Square head type W7 x H9 x D13.9	750 570 350 290	200 90 100	0.06mm opaque object	2m	R1mm	FT-WR80
		With lens W7 x H9 x D14.6	1500 1200 750 600	420 200 210	0.04mm opaque object			FT-WR80L
	Elbow	Lens mountable	740 530 320 230	150 75 80	0.04mm opaque object	2m	R25mm	FT-R80
	M3	Lens mountable (except FX-LE2)	1000 780 500 400	280 150 130	0.03mm opaque object		R25mm	FT-T80
								FT-NFM2
		Sleeve 90mm ø0.88	400 270 200 140	100 55 49	0.025mm opaque object	2m	Fiber R25mm Sleeve R10mm	FT-NFM2S FT-NFM2S4
Sleeve 40mm ø0.88								
		220 160 100 80	55 25 28	0.02mm opaque object		R1mm	FT-W4	
		350 250 150 100	75 30 35			R4mm Flexible	FT-P40	
Long sensing range		With lens M14	19,500 19,500 14,000	10,000 3,500 3,800	0.4mm opaque object	10m	R25mm	FT-FM10L

Notes: 1) Please take care that the sensing range of the free-cut type fiber may be reduced by 20% max. depending upon how the fiber is cut.
 2) The minimum sensing object size is the value for red LED type. Please contact our office for information on the minimum sensing object size if using amplifiers other than red LED type.
 The optimum condition is the condition when the sensitivity is set so that the sensing output just changes to light incident operation in the object absent condition.

Pliable fibers (flexible and sharp bending fibers) are marked with light red in the table.

Optical Fibers for FX 300 Series

Thru-beam type (one pair set)



The FX-305 and FX-301(-HS) have different sensing modes.
 FX-305: H-SP, FAST, STD, STDF, LONG, U-LG (no S-D mode)
 FX-301(-HS): S-D, H-SP (Note 1), FAST, STD, LONG (no STDF or U-LG mode)

Type	Shape of fiber head (mm)	Sensing range (mm) (Note 1)	: U-LG : LONG : STDF : STD	: FAST : H-SP : S-D	Min. sensing object (Note 2)	Fiber cable length ✂: Free-cut	Bending radius	Model no.	
Cylindrical type	With lens • Long sensing range ø3	1500 1200 750 600	420 200 210		ø0.02mm opaque object	✂ 2m	R1mm	FT-WS8L	
		780 570 340 290	200 90 100		ø0.05mm opaque object			FT-WS3	
	With lens • Long sensing range ø2.5	2000 1600 820 800	580 170 280		ø0.02mm opaque object	✂ 2m	R25mm	FT-SFM2L	
		1000 780 500 400	280 150 130		ø0.03mm opaque object			FT-SFM2	
		750 350 570 290	200 90 100		ø0.025mm opaque object			R1mm FT-WS8	
	ø1.5	400 270 200 140	100 55 49		ø0.025mm opaque object	✂ 2m	R25mm	FT-SNFM2	
		220 160 100 80	55 25 28		ø0.02mm opaque object			R1mm FT-WS4	
		350 280 160 120	90 40 42		ø0.02mm opaque object			1m R4mm FT-P2	
	ø1	100 50 40	30 13 17		ø0.02mm opaque object	500mm	Flexible	FT-PS1	
	Ultra small diameter	Beam diameter ø0.125 mm ø0.25 ø3	20 18 13 10	8 3 3		ø0.02mm opaque object	500mm	R5mm	FT-E12
		Sleeve part cannot be bent. Beam diameter ø0.4 ø3 ø0.25 mm	130 80 60 50	36 18 15		ø0.02mm opaque object	1m		FT-E22
		Sleeve part cannot be bent.							
Side-view	ø4	2350 2000 1400 1000	800 340 350		ø0.05mm opaque object	✂ 2m	R25mm	FT-V10	
	ø1.5 ø2.5	550 400 240 200	140 65 70		ø0.02mm opaque object			FT-SFM2SV2	
	ø1 ø2	410 390 220 180	125 60 63		ø0.02mm opaque object			1m	FT-V22
	ø1 ø2.5	220 175 100 80	60 25 27		ø0.02mm opaque object			✂ 2m	FT-V41
	ø1 ø2	120 90 55 40	30 13 15		ø0.02mm opaque object			R1mm FT-WV42	

Notes: 1) Please take care that the sensing range of the free-cut type fiber may be reduced by 20% max. depending upon how the fiber is cut.
 2) The minimum sensing object size is the value for red LED type. Please contact our office for information on the minimum sensing object size if using amplifiers other than red LED type.
 The optimum condition is the condition when the sensitivity is set so that the sensing output just changes to light incident operation in the object absent condition.

Pliable fibers (flexible and sharp bending fibers) are marked with light red in the table.

Optical Fibers for FX 300 Series

Standard Fibers

Thru-beam type (one pair set)

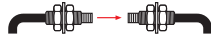

The **FX-305** and **FX-301(-HS)** have different sensing modes.
FX-305: H-SP, FAST, STD, STDF, LONG, U-LG (no S-D mode)
FX-301(-HS): S-D, H-SP (Note 1), FAST, STD, LONG (no STDF or U-LG mode)

Type	Shape of fiber head (mm)	Sensing range (mm) (Note 1)	: U-LG : LONG : STDF : STD	: FAST : H-SP : S-D	Min. sensing object (Note 2)	Fiber cable length ✂ : Free-cut	Bending radius	Model no.	
Rectangular	Compact	Easy mounting • Top sensing W3 × H8 × D12	3500 2500 1600 1200	850 400 410	ø0.08mm opaque object	✂ 2m	R1mm	FT-WZ8H	
		Easy mounting • Side sensing W3 × H12 × D8	3100 2700 1550 1400	1000 420 490	ø0.03mm opaque object		R4mm Flexible	FT-Z8H	
		Easy mounting • Front sensing W8.5 × H12 × D3	2100 1500 950	500 200 210	ø0.05mm opaque object		R1mm	FT-WZ8E	
		Front sensing	1850 1600 950 800	600 250 280	ø0.03mm opaque object		R4mm Flexible	FT-Z8E	
		Fiber bending type	950 700 420 330	240 100 120	ø0.04mm opaque object		R1mm	FT-WZ8	
	Narrow beam	Front sensing	1100 800 500 400	300 120 140	ø0.03mm opaque object		R4mm Flexible	FT-Z8	
		Front sensing	W10 × H7 × D2	300 200 140 100	70 40 40		ø0.08mm opaque object	✂ 1m	NEW FT-WZ4
		Fiber bending type	W2 × H10 × D10	220 150 105 75	50 30 30		ø0.08mm opaque object	R1mm	NEW FT-WZ4HB
		Front sensing	W14 × H7 × D3.5	660 440 308 220	150 80 80		ø0.08mm opaque object	✂ 2m	NEW FT-WZ7
		Fiber bending type	W3.5 × H14 × D11	870 580 406 290	210 110 110		ø0.03mm opaque object	NEW FT-WZ7HB	
Special	Narrow beam	Side-view type with small light dispersion	3000 2000 1500 1000	800 300 350		R25mm R0.984 in	FT-K8		
		Wide area sensing	2200 1700 1000	600 280 300	ø0.06mm opaque object	R1mm	FT-WKV8		
		Wide area sensing	3000 2000 1500 1000	800 300 350		R25mm R0.984 in	FT-KV8		
	Wide beam	Wide area sensing	W2 × H1.5 × D20	600 500 300 250	180 90 100	ø0.02mm opaque object	R10mm	FT-KV1	
		Wide area sensing	W5 × H69 × D20	(Note 3) 3500 (Note 3) 3500 (Note 3) 3500 (Note 3) 3500	(Note 4) 3500 (Note 4) 3000 (Note 4) 3500	ø0.3mm opaque object	R1mm	FT-WA30	
		Wide area sensing	W4.2 × H31 × D13.5	(Note 3) 3500 (Note 3) 3500 (Note 3) 3500 1500	1100 1080 750	ø0.25mm opaque object	R1mm	FT-WA8	
Array	Top sensing	W5 × H15 × D15	850 650 380 330	220 100 115	Horizontal: ø0.025mm opaque object	✂ 2m	R25mm	FT-AFM2	
	Side sensing	W5 × H15 × D15	800 590 350 290	200 90 100	Vertical: ø0.45mm opaque object		FT-AFM2E		

Notes: 1) Please take care that the sensing range of the free-cut type fiber may be reduced by 20% max. depending upon how the fiber is cut.
 2) The minimum sensing object size is the value for red LED type. Please contact our office for information on the minimum sensing object size if using amplifiers other than red LED type. The optimum condition is the condition when the sensitivity is set so that the sensing output just changes to light incident operation in the object absent condition.
 3) The fiber cable length practically limits the sensing range to 3500mm long.

Pliable fibers (flexible and sharp bending fibers) are marked with light red in the table.

Optical Fibers for FX 300 Series

Thru-beam type (one pair set)



FX-305 / FX-301 (Red LED type) sensing range (Note 1)

The **FX-305** and **FX-301(-HS)** have different sensing modes.
FX-305: H-SP, FAST, STD, STDF, LONG, U-LG (no S-D mode)
FX-301(-HS): S-D, H-SP (Note 1), FAST, STD, LONG (no STDF or U-LG mode)

Type	Shape of fiber head (mm)	Sensing range (mm) (Note 2)	U-LG LONG STDF STD	FAST H-SP S-D	Min. sensing object (Note 3)	Fiber cable length ✂ : Free-cut	Bending radius	Model no.	
Heat-resistant	350°C Lens mountable 					ø0.04mm opaque object	2m Fiber R25mm Sleeve R10mm	R25mm	FT-H35-M2
	350°C Sleeve 60mm 					ø0.04mm opaque object	2m Fiber R25mm Sleeve R10mm	R25mm	FT-H35-M2S6
	Allows flexible wiring, 200°C Lens mountable 					ø0.02mm opaque object	1m R10mm	R10mm	FT-H20W-M1
	200°C Lens mountable 					ø0.04mm opaque object	1m R25mm	R25mm	FT-H20-M1
	130°C Lens mountable (FX-LE2 only) 					ø0.06mm opaque object	2m ✂	✂	FT-H13-FM2
	Lens mountable (FX-LE1) 					ø0.12mm opaque object	200mm (Note 4) 300mm (Note 4) 500mm (Note 4)	Heat-resistant fiber R18mm (Note 5)	FT-H20-J20-S (Note 6) FT-H20-J30-S (Note 6) FT-H20-J50-S (Note 6)
Special	Side-view 				ø0.16mm opaque object	500mm (Note 4) 800mm (Note 4)	Heat-resistant fiber R18mm (Note 5)	FT-H20-VJ50-S (Note 6) FT-H20-VJ80-S (Note 6)	
	Easy mounting - Rectangular head SEMI S2 compliant W7 x H15 x D13 					ø4mm opaque object	2m ✂	R25mm	FT-Z802Y
	Heat-resistant 115°C 					ø0.2mm opaque object	2m (Note 7) ✂	R30mm	FT-HL80Y FT-L80Y FT-V80Y
	Side-view 					ø0.2mm opaque object	2m (Note 7) ✂	R30mm	FT-HL80Y FT-L80Y FT-V80Y
Vacuum-resistant	300°C Lens mountable (FV-LE1/SV2 only) 				ø0.03mm opaque object	1m ✂	R1mm	FT-H30-M1V-S (Note 8)	

- Notes:**
- 1) Contact our office for details regarding the sensing ranges of the **FX-301-HS** in H-SP mode and the **FX-301B/G/H**.
 - 2) Please take care that the sensing range of the free-cut type fiber may be reduced by 20% max. depending upon how the fiber is cut.
 - 3) The minimum sensing object size is the value for red LED type. Please contact our office for information on the minimum sensing object size if using amplifiers other than red LED type.
The optimum condition is the condition when the sensitivity is set so that the sensing output just changes to light incident operation in the object absent condition.
 - 4) This is the fiber length (fixed length) for heat-resistant fibers. The ordinary-temperature fibers are free-cut to 2m.
 - 5) The bending radius for the ordinary-temperature fiber is R25mm or more.
 - 6) Heat-resistant joint fibers and ordinary-temperature fibers (**FT-FM2**) are sold as a set.
 - 7) The allowable cutting range is 500mm from the end that the amplifier inserted.
 - 8) Sold as a set comprising vacuum type fiber + photo-terminal (**FV-BR1**) + fiber at atmospheric side (**FT-J8**).

Model no. when ordering heat-resistant joint fibers individually as replacement parts

FT-H20-J20 (one pair set) **FT-H20-J30** (one pair set) **FT-H20-J50** (one pair set)
FT-H20-VJ50 (one pair set) **FT-H20-VJ80** (one pair set)

Model no. when ordering vacuum-resistant fibers individually as replacement parts

Vacuum-resistant fiber Photo-terminal Fiber at atmospheric side
FT-H30-M1V (one pair set) **FV-BR1** (one pair set) **FT-J8** (one pair set)

Optical Fibers for FX 300 Series

Retroreflective type



FX-305 / FX-301 (Red LED type) sensing range (Note 1)

The **FX-305** and **FX-301(-HS)** have different sensing modes.
FX-305: H-SP, FAST, STD, STDF, LONG, U-LG (no S-D mode)
FX-301(-HS): S-D, H-SP (Note 1), FAST, STD, LONG (no STDF or U-LG mode)

Type	Shape of fiber head (mm)	Sensing range (mm) (Notes 2, 3)	U-LG LONG STDF STD	FAST H-SP S-D	Min. sensing object (Note 4)	Fiber cable length Free-cut	Bending radius	Model no.
Sharp bending Wiring/zippering fibers	W9.5 × H5.2 × D15	100 to 910 100 to 730 100 to 600 100 to 520 (Note 3)	Cannot use Cannot use	100 to 460	ø0.3mm opaque object	2m	R1mm	FR-WKZ11
	W30 × H30 × D0.5 W9.5 × H5.2 × D21							
Narrow beam	Top sending W10.6 × H28 × D10.1	200 200 200		200 200 200	Horizontal: ø5.5mm opaque object	2m	R10mm	FR-KZ21
	Side sending W5 × H25 × D5.2 W10.6 × H28 × D10.1	200		200	Vertical: ø0.06mm opaque object			FR-KZ21E
Water mapping	W7.5 × H2.2 × D11.2 W4 × H2 × D21.5	15 to 370 15 to 330 15 to 240 15 to 210		15 to 170 15 to 80 15 to 90	ø0.12mm opaque object	2m	R10mm	FR-KV1

- Notes:**
- Contact our office for details regarding the sensing ranges of the **FX-301(-HS)** in H-SP mode and the **FX-301B/G/H**.
 - Please take care that the sensing range of the free-cut type fiber may be reduced by 20% max. depending upon how the fiber is cut. The sensing range of **FR-WKZ11** is specified for the **RF-13**. The sensing range of **FR-KZ21**, **FR-KZ21E** is specified for the attached reflector **RF-003**. The sensing range of **FR-KV1** is specified for the attached reflector.
 - The sensing range of **FR-KV1** is the possible setting range for the reflector. The fiber can detect an object less than 15mm away. The sensing range of **FR-KZ21** and **FR-KZ21E** is the possible setting range for the reflector. However, if setting the fiber to detect objects passing within 0 to 20mm from the fiber head, unstable detection may result. The sensing range of **FR-WKZ11** is the possible setting range for the reflective tape. The fiber can detect an object less than 100mm away. However, note that if there are any white or highly-reflective surfaces near the fiber head, reflected incident light may affect the fiber head. If this occurs, adjust the threshold value of the amplifier unit before use.
 - The minimum sensing object size is the value for red LED type. The optimum condition is the condition when the sensitivity is set so that the sensing output just changes to light incident operation in the object absent condition.

Reflective type



The **FX-305** and **FX-301(-HS)** have different sensing modes.
FX-305: H-SP, FAST, STD, STDF, LONG, U-LG (no S-D mode)
FX-301(-HS): S-D, H-SP (Note 1), FAST, STD, LONG (no STDF or U-LG mode)

Type	Shape of fiber head (mm)	Sensing range (mm) (Notes 1, 2)	U-LG LONG STDF STD	FAST H-SP S-D	Min. sensing object (Note 3)	Fiber cable length Free-cut	Bending radius	Model no.
Threaded type M6	M6	600 480 280 220		160 85 75	ø0.02mm gold wire	2m	R25mm	FD-B8
	Coaxial M6	410 310 200 140		100 55 47				FD-FM2
	Sleeve 90mm M6	370 270		85 45			Fiber R25mm Sleeve	FD-FM2S
	Sleeve 40mm M6	170 110		39			R10mm	FD-FM2S4
	M6	250 190 110 90		60 25 32			R1mm	FD-W8
	M6	300 220 130 100		70 30 35			R4mm Flexible	FD-P80
	M6 Tough flexible	270 185 100 80		60 30 35			R10mm	FD-P81X
Elbow M6	240 185 110 85		60 25 30	ø0.02mm gold wire	2m	R25mm	FD-R80	

- Notes:**
- The sensing range is specified for white non-glossy paper [400 × 400mm] as the object.
 - Please take care that the sensing range of the free-cut type fiber may be reduced by 20% max. depending upon how the fiber is cut.
 - The minimum sensing object size is the value for red LED type at maximum sensitivity. Note that the corresponding setting distance is different from the rated sensing distance.

Pliable fibers (flexible and sharp bending fibers) are marked with light red in the table.

Optical Fibers for FX 300 Series

Reflective type



The FX-305 and FX-301(-HS) have different sensing modes.
 FX-305: H-SP, FAST, STD, STDF, LONG, U-LG (no S-D mode)
 FX-301(-HS): S-D, H-SP (Note 1), FAST, STD, LONG (no STDF or U-LG mode)

Type	Shape of fiber head (mm)	Sensing range (mm) (Notes 1, 2)	U-LG : LONG S-TDF STD	FAST : H-SP S-D	Min. sensing object (Note 3)	Fiber cable length ✂ : Free-cut	Bending radius	Model no.			
Threaded type	M4		370 270 170 110	85 45 39	ø0.02mm gold wire	✂ 2m	R25mm	FD-T80			
	M4						R25mm	FD-NFM2			
	Sleeve 90 mm		140 90 60 45	35 16 16			Fiber R25mm Sleeve	FD-NFM2S			
	Sleeve 40mm						R10mm	FD-NFM2S4			
	Sleeve 40mm 1.575 in		40 30 18 15	12 4.5 5			Fiber R1mm Sleeve R10mm	FD-W44			
	M4		250 190 110 90	60 25 32			R1mm	FD-WT8			
	Minute objects can be detected due to the small spot beam. Coaxial • Lens mountable		85 65 37 32	25 10 11			R2mm	FD-WG4			
	M4		150 110 65 55	42 15 19			R25mm	FD-G4			
	M4		130 90 55 45	30 13 16			R4mm Flexible	FD-P60			
	Small diameter		140 90 60 45	35 16 16			ø0.02mm gold wire	✂ 2m	R25mm	FD-T40	
	M3		40 30 18 15	12 4.5 5					R1mm	FD-WT4	
	M3		50 36 20 18	14 5.5 6					R4mm Flexible	FD-P40	
	Lens mountable (FX-MR3, FX-MR6)		150 110 65 55	42 15 19					R25mm	FD-G6	
	Lens mountable (FX-MR3, FX-MR6)		150 90 48 45	35 12 20					✂ 1m (Note 4)	R10mm	FD-G6X
Coaxial Tough flexible				ø0.04mm gold wire	500mm	R25mm			FD-EG1		
Coaxial • Lens mountable (FX-MR3, FX-MR6)		50 38 25 18	14 5 6			R25mm			FD-EG2		
High precision						R25mm			FD-EG3		
Coaxial • Lens mountable (FX-MR3, FX-MR6)		40 25 14 12	9 3 5			R10mm			FD-EG2		
Coaxial • Lens mountable (FX-MR3, FX-MR6)		20 15 9 8	5 2.5 3			FD-EG3					
High precision ø0.175						ø0.02mm gold wire			1m	R25mm	FD-EN500S1
Coaxial • Lens mountable (FX-MR3, FX-MR6)		6.5 5 3 3	2 Cannot use Cannot use							FD-EN500S1	
Sleeve part cannot be bent.		50 38 20 18	14 5 6							FD-ENM1S1	
Coaxial ø0.8										FD-ENM1S1	

- Notes: 1) The sensing range is specified for white non-glossy paper [200 × 200mm (FD-T80, FD-WT8: 400 × 400mm, FD-W44, FD-WT4, FD-P40, FD-G6, FD-EG1, FD-EG2, FD-EG3, FD-EN500S1, FD-ENM1S1: 100 × 100mm)] as the object.
 2) Please take care that the sensing range of the free-cut type fiber may be reduced by 20% max. depending upon how the fiber is cut.
 3) The minimum sensing object size is the value for red LED type at maximum sensitivity.
 Note that the corresponding setting distance is different from the rated sensing distance.
 4) The allowable cutting range is 700mm from the end that the amplifier inserted.

Pliable fibers (flexible and sharp bending fibers) are marked with light red in the table.

Optical Fibers for FX 300 Series

Reflective type



The **FX-305** and **FX-301(-HS)** have different sensing modes.
FX-305: H-SP, FAST, STD, STDF, LONG, U-LG (no S-D mode)
FX-301(-HS): S-D, H-SP (Note 1), FAST, STD, LONG (no STDF or U-LG mode)

Type	Shape of fiber head (mm)	Sensing range (mm) (Notes 1, 2)	U-LG LONG STDF STD	FAST H-SP S-D	Min. sensing object (Note 3)	Fiber cable length Free-cut	Bending radius	Model no.
Cylindrical type	ø3		370 270 170 110	85 45 39	ø0.02mm gold wire	2m	R25mm	FD-S80
			250 190 110	60 25 32	ø0.02mm gold wire	2m	R1mm	FD-WS8
		Coaxial 	90 85 37 32	25 10 11	ø0.02mm gold wire	2m	R2mm	FD-WSG4
			130 90 55 45	30 13 16	ø0.02mm gold wire	2m	R4mm Flexible	FD-P50
	ø2.5		140 90 60 45	35 16 16	ø0.02mm gold wire	2m	R25mm	FD-SNFM2
	ø1.5		80 50 30 25	19 7.5 9	ø0.02mm gold wire	1m	R4mm Flexible	FD-P2
	Ultra small diameter		15 11 8 6	4 2 1	ø0.02mm gold wire	1m	R10mm	FD-E12
		Coaxial 	65 45 28 23	17 8 7	ø0.02mm gold wire	1m	R25mm	FD-E22
	Side-view	Small diameter 	80 55 30 25	17 8 9	ø0.02mm gold wire	2m	R25mm	FD-V41
			20 15 8.5 7	5 Cannot use Cannot use	ø0.02mm gold wire	2m	R1mm	FD-WV42
		170 100 55 45	32 15 16	ø0.02mm gold wire	2m	R25mm	FD-SFM2SV2	
Rectangular	Glass substrate detection • Mapping 	12 to 50 12.5 to 37.5 15 to 36 15 to 35	16 to 29 Cannot use Cannot use	ø0.3mm gold wire	4m	R25mm	FD-L46	
	Glass substrate detection • Alignment 	0 to 50 0 to 36 0 to 33 0 to 30	0 to 30 0 to 15 0 to 21	(LCD glass)	3m	R4mm	FD-L45	
	Glass substrate detection • Alignment 	0 to 23		(LCD glass)	2m	R4mm	FD-L43	
	Glass substrate detection • Seating confirmation 	0 to 8.2 0 to 7 0 to 6.5 0 to 6	0 to 5.7 0 to 5 0 to 5.2	ø0.03mm gold wire	2m	R10mm	FD-L44	
	W12 × H19 × D3 	0 to 4.7 0 to 4.5 0 to 4 0 to 4	0 to 3.8 0 to 3 0 to 3.5	ø0.03mm gold wire	2m	R10mm	FD-L44S	
	Glass substrate detection 	6.5 to 14.5 (Convergent point 8) 6.5 to 14 (Convergent point 8) 7 to 14 (Convergent point 8) 7 to 12 (Convergent point 8)	7.5 to 12 (Convergent point 8) Cannot use Cannot use	ø1.9mm metal pipe (gray)	2m	R1mm	FD-WL41	
	W24 × H21 × D4 	2 to 19 (Convergent point 8) 2.5 to 18 (Convergent point 8) 3 to 16 (Convergent point 8) 3 to 16 (Convergent point 8)	3.5 to 15 (Convergent point 8) Cannot use Cannot use	ø0.06mm gold wire	2m	R10mm	FD-L41	
	W6 × H18 × D14 	2 to 20 (Convergent point 6) 2.5 to 18 (Convergent point 6) 4 to 12 (Convergent point 6) 4 to 12 (Convergent point 6)	4.5 to 11 (Convergent point 6) 5 to 8.5 (Convergent point 6) 4.8 to 9.5 (Convergent point 6)	ø0.02mm gold wire	2m	R10mm	FD-L4	
W7.2 × H7.5 × D2 	0.5 to 8.5 0.5 to 7.5 1 to 6.5 1 to 5.5	1 to 5 Cannot use Cannot use	ø0.3mm copper wire	1m	R1mm	FD-WL48		

- Notes: 1) The sensing range is specified for white non-glossy paper (FD-S80, FD-WS8: 400 × 400mm, FD-WSG4, FD-P50, FD-SNFM2, FD-V41, FD-SFM2SV2: 200 × 200mm, FD-P2, FD-E12, FD-E22, FD-WV42, FD-L4, FD-WL48: 100 × 100mm, FD-L46: 100 × 100 × t 0.7mm R edge of LCD glass substrates, FD-L43, FD-L44 and FD-L45: 100 × 100 × t 0.7mm LCD glass substrates, FD-L44S: silicon wafers polished surface, FD-WL41, FD-L41: 100 × 100 × t 2mm glass substrates) as the object.
 2) Please take care that the sensing range of the free-cut type fiber may be reduced by 20% max. depending upon how the fiber is cut.
 3) The minimum sensing object size is the value for red LED type at maximum sensitivity. Note that the corresponding setting distance is different from the rated sensing distance. However, with the convergent reflective type, when the sensitivity is at MAX., it is only possible to detect the minimum size of the sensing object at a distance corresponding to the convergent point.

Pliable fibers (flexible and sharp bending fibers) are marked with light red in the table.

Optical Fibers for FX 300 Series

Reflective type



FX-305 / FX-301 (Red LED type) sensing range (Note 1)

The **FX-305** and **FX-301(-HS)** have different sensing modes.
FX-305: H-SP, FAST, STD, STDF, LONG, U-LG (no S-D mode)
FX-301(-HS): S-D, H-SP (Note 1), FAST, STD, LONG (no STDF or U-LG mode)

Type	Shape of fiber head (mm)	Sensing range (mm) (Notes 1, 2)	U-LG : LONG : STDF : STD	FAST : H-SP : S-D	Min. sensing object (Note 3)	Fiber cable length ☒ : Free-cut	Bending radius	Model no.
Rectangular	Small	Front sensing 1 to 50 1.5 to 34 2 to 24 3 to 17	3 to 10 Cannot use Cannot use		ø0.16mm copper wire	☒ 1m		FD-WZ4
		Fiber bending type 1 to 70 1 to 46 1 to 32.2 2.5 to 23	2.5 to 15 3 to 7 3 to 7					R1mm
	Front sensing 200 120 1 to 84 1 to 60	1.5 to 35 2.5 to 18 2.5 to 18			ø0.03mm gold wire	☒ 2m		FD-WZ7
		Fiber bending type 0.5 to 270 0.5 to 180 1 to 126 1 to 90	1 to 70 1 to 35 1 to 35					
Special	Long sensing range • Rectangular head 20 to 660 20 to 480 20 to 300 20 to 230	20 to 170 25 to 90 25 to 100			ø0.3mm copper wire	☒ 2m	R1mm	FD-WKZ1
	Wide beam 230 200 150 150	100 45 50			ø0.02mm gold wire	☒ 2m	R25mm	FD-A15
	Array Top sensing 290 220	78 35 39			ø0.02mm gold wire	☒ 2m	R25mm	FD-AFM2
	Side sensing 135 110							FD-AFM2E
	Mountable on pipe • Standard W25 x H13 x D20	—			(Liquid)	☒ 2m (Note 5)	Protective tube R40mm Fiber R15mm	FD-F8Y)
Mountable on pipe • For PFA, wall thickness 1mm pipe W25 x H13 x D20	—			(Liquid)	☒ 2m	R10mm	FD-F41	
Mountable on pipe SEMI S2 compliant W23 x H20 x D17	—			(Liquid)	☒ 2m	Protective tube R20mm Fiber R4mm	FD-F902 (Note 5)	
SEMI S2 compliant W20 x H30 x D10	—			(Liquid)	☒ 5m (Protective tube: 3m)	Protective tube R20mm Fiber R4mm	FD-F705 (Note 5)	

- Notes: 1) The sensing range is specified for white non-glossy paper [200 × 200mm (FD-WKZ1, FD-AFM2, FD-AFM2E: 400 × 400mm)] as the object.
 2) Please take care that the sensing range of the free-cut type fiber may be reduced by 20% max. depending upon how the fiber is cut.
 3) The minimum sensing object size is the value for red LED type at maximum sensitivity. Note that the corresponding setting distance is different from the rated sensing distance.
 4) The allowable cutting range is 1000mm from the end at which the amplifier is inserted.
 5) The dedicated amplifier **FX-301-F** must be used with **FT-F902** and **FD-F705**.

Pliable fibers (flexible and sharp bending fibers) are marked with light red in the table.

Optical Fibers for FX 300 Series

Reflective type



The **FX-305** and **FX-301(-HS)** have different sensing modes.
FX-305: H-SP, FAST, STD, STDF, LONG, U-LG (no S-D mode)
FX-301(-HS): S-D, H-SP (Note 1), FAST, STD, LONG (no STDF or U-LG mode)

Type	Shape of fiber head (mm)	Sensing range (mm) (Notes 1, 2)	U-LG LONG STDF STD	FAST H-SP S-D	Min. sensing object (Note 3)	Fiber cable length Free-cut	Bending radius	Model no.	
Special	Heat-resistant								
	350°C • Coaxial					2m	R25mm	FD-H35-M2	
	350°C • Sleeve 60mm	300 270 150 140	100	35 47			Fiber R25mm Sleeve R10mm	FD-H35-M2S6	
	200°C • Coaxial					1m	R25mm	FD-H20-M1	
	350°C • Sleeve 90mm	190 160 80 80	57	20 26			Fiber R25mm Sleeve R10mm	FD-H35-20S	
	200°C • Coaxial	300 270 150 140	100	35 47				FD-H20-21	
	300°C • Glass substrate detection Convergent reflective type	0 to 20 0 to 15 0 to 10 0 to 10	1 to 8 Cannot use 2 to 6			2m			FD-H30-L32
	180°C • Glass substrate detection Convergent reflective type	0 to 20 0 to 15 0 to 10 0 to 10	1 to 8 Cannot use 2 to 6				R25mm		FD-H18-L31
	130°C • Coaxial	410 310 200 140	100	55 47			2m		FD-H13-FM2
	Vacuum-resistant								
300°C • Rectangular head W9.5 × H5.2 × D15	20 to 300 20 to 200 20 to 150 25 to 130	30 to 100 Cannot use Cannot use			1m			FD-H30-KZ1V-S (Note 4)	
300°C • Glass substrate detection Convergent reflective type	0 to 11 0 to 8 1.5 to 6 1.5 to 5	2 to 4 Cannot use Cannot use			3m		R18mm	FD-H30-L32V-S (Note 4)	

- Notes:** 1) The sensing range is specified for white non-glossy paper [400 × 400mm (FD-H30-L32, FD-H18-L31: 50 × 50mm glass substrate, FD-H30-KZ1V-S, FD-H30-L32V-S: 100 × 100 × 1.0/7mm transparent glass)] as the object.
 2) Please take care that the sensing range of the free-cut type fiber may be reduced by 20% max. depending upon how the fiber is cut.
 3) The minimum sensing object size is the value for red LED type at maximum sensitivity. Note that the corresponding setting distance is different from the rated sensing distance.
 4) Sold as a set comprising vacuum type fiber + photo-terminal (FV-BR1) + fiber at atmospheric side (FT-J8).

Model no. when ordering vacuum-resistant fibers individually as replacement parts

- Vacuum-resistant fiber
- FD-H30-KZ1V
- FD-H30-L32V
- Mounting bracket for FD-H30-KZ1V
- MS-FD-2
- Photo-terminal
- FV-BR1 (one pair set)
- Fiber at atmospheric side
- FT-J8 (one pair set)

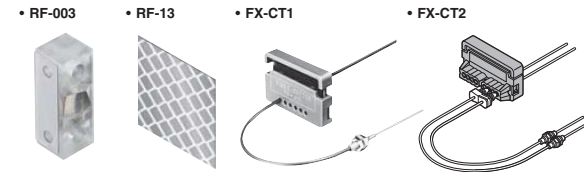
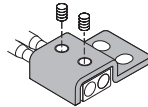

Accessories (attached with fibers)

- RF-003 (FR-KZ21/KZ21E exclusive reflector)
- RF-13 (Reflective tape)
- FX-CT1 (Fiber cutter)
- FX-CT2 (Fiber cutter)
- FX-AT2 (Attachment for fixed-length fiber, Orange)
- FX-AT3 (Attachment for ø2.2mm fiber, Clear orange)
- FX-AT4 (Attachment for ø1mm fiber, Black)
- FX-AT5 (Attachment for ø1.3mm fiber, Gray)
- FX-AT6 (Attachment for ø1mm / ø1.3mm mixed fiber, Black / Gray)

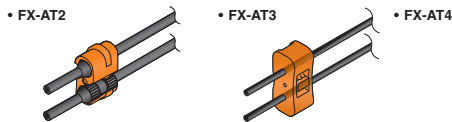

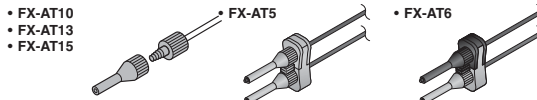

If connecting to the FX2 / FX3 series

- FX-AT10 (Attachment for ø1mm fiber)
- FX-AT13 (Attachment for ø1.3mm fiber)
- FX-AT15 (Attachment for ø1mm / ø1.3mm mixed fiber)

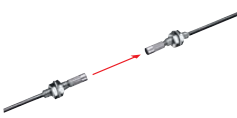
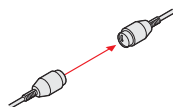

Accessories for the FX 300 Series

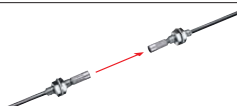
Accessories for retroreflective fiber optics					
Figure	Description	Effective distance (with FX-301)			Model no.
		Fiber optics	Sensing range*	Sensing range**	
	Effective distance expanded 5 times or more; Ambient temperature: -60°C to +350°C	FT-B8	2500	3500	FX-LE1
		FT-FM2	3500	3500	
		FT-T80	3500	3500	
		FT-R80	2300	3500	
		FT-W8	2900	3500	
		FT-P80	3500	3500	
		FT-P60	3500	3500	
		FT-H35M2	2000	3500	
		FT-H20WM1	1300	1600	
		FT-H20WM2	1300	3500	
FT-H20M1	1600	1000			
	Tremendously increases the sensing range with large diameter lenses Ambient temperature: -60°C to +350°C	FT-B8	3500	3500	FX-LE2
		FT-FM2	3500	3500	
		FT-T80	3500	3500	
		FT-R80	3500	3500	
		FT-W8	2900	3500	
		FT-P80	3500	3500	
		FT-P60	3500	3500	
		FT-H35M2	3500	3500	
		FT-H20WM1	1600	1600	
		FT-H20WM2	3500	1600	
		FT-H20M1	1600	1600	
		FT-H13	3500	1600	
			Beam axis is bent by 90° Ambient temperature: -60°C to +350°C	FT-B8	
FT-FM2	600			1200	
FT-T80	600			1200	
FT-W8	450			900	
FT-P80	600			1200	
FT-P60	300			650	
FT-H35M2	280			550	
FT-H20WM1	140			310	
FT-H20WM2	140			310	
FT-H20M1	280	550			
	Sensing range increases by 15 times or more Ambient temperature: -40°C to +120°C	FT-6V	2700	3500	FV-LE1
		FT-60V	1450	3500	

* The indicated values (red, green, blue infrared) refer to response time "Standard"

** Red (max.) refers to response time "Ultralong"

Accessories for the FX Series

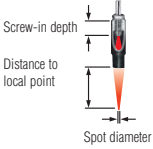
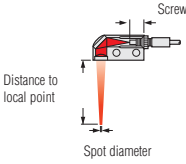
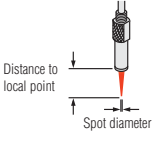
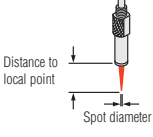
Accessories for retroreflective fiber optics						
Figure	Description	Effective distance (with FX-301)			Model no.	
		Fiber	Screw-in depth	Spot diameter		
	Pinpoint spot of Ø 0.5mm enables detection of minute objects or small marks Applicable fibers: FD-WG4 / FD-G4 Ambient temperature: -40°C to +70°C	FD-WG4	6mm ± 1mm	Ø 0.5mm	FX-MR1	
		FD-G4	6mm ± 1mm	Ø 0.5mm		
Figure	Description	Effective distance (with FX-301)			Model no.	
		Fiber	Screw-in depth	Distance to local point		Spot diameter
	The spot diameter is adjustable from 0.7mm to Ø2mm according to how far the fiber is screwed in. Ambient temperature: -40°C to +70°C	FD-WG4	7mm	approx. 18.5mm	Ø 0.7mm	FX-MR2
			12mm	approx. 27mm	Ø 1.2mm	
			14mm	approx. 43mm	Ø 2.0mm	
		FD-G4	7mm	approx. 18.5mm	Ø 0.7mm	
12mm	approx. 27mm		Ø 1.2mm			
14mm	approx. 43mm		Ø 2.0mm			
Figure	Description	Effective distance (with FX-301)			Model no.	
		Fiber	Screw-in depth	Distance to local point		Spot diameter
	FX-MR2 is converted into a sideview type and can be mounted in a very small space. Ambient temperature: -40°C to +70°C	FD-WG4	8mm	approx. 13mm	Ø 0.5mm	FX-MR5
			10mm	approx. 15mm	Ø 0.8mm	
			14mm	approx. 30mm	Ø 3.0mm	
		FD-G4	8mm	approx. 13mm	Ø 0.5mm	
10mm	approx. 15mm		Ø 0.8mm			
14mm	approx. 30mm		Ø 3.0mm			
Figure	Description	Effective distance (with FX-301)			Model no.	
		Fiber	Screw-in depth	Spot diameter		
	Extremely fine spot of approx. Ø 0.3mm achieved Ambient temperature: -40°C to +70°C	FD-WG4	7.5mm ± 0.5mm	Ø 0.5mm	FX-MR3	
		FD-G4	7.5mm ± 0.5mm	Ø 0.5mm		
		FD-EG1	7.5mm ± 0.5mm	Ø 0.3mm		
		FD-EG3	7.5mm ± 0.5mm	Ø 0.15mm		
Figure	Description	Effective distance (with FX-301)			Model no.	
		Fiber	Screw-in depth	Spot diameter		
	Extremely fine spot of approx. Ø 0.3mm achieved Ambient temperature: -40°C to +70°C	FD-WG4	7mm ± 0.5mm	Ø 0.4mm	FX-MR6	
		FD-G4	7mm ± 0.5mm	Ø 0.4mm		
		FD-EG1	7mm ± 0.5mm	Ø 0.2mm		
		FD-EG3	7mm ± 0.5mm	Ø 0.1mm		

FD-L40



Fibers for liquid crystal display industry

Features

Mapping Fiber

FD-L46

The adoption of a unique large lens allows even thin glass substrates to be sensed directly from the side. In addition, due to the wide sensing range (25±12.5mm), stable mapping is possible even if glass substrates are in irregular positions.

Variety of glass substrates

FD-L46

Large light amounts can be obtained for a variety of glass edge shapes such as R surfaces and C surfaces, so that accurate mapping of glass substrates inside cassettes is possible. Glass that has received black or yellow masking can also be sensed in addition to clear glass.

Alignment fiber

FD-L43 / FD-L45

Increases in size of glass substrates mean greater amounts of flexure, but a single fiber can sense glass even if horizontal flexure is within ±8° (FD-L45% ± 6°).

A sensing range of 3 to 17mm (FD-L45: 10 to 25mm) and a positioning error of 0.2mm or less makes higher precision sensing possible.

Seating confirmation fiber

FD-L44 / FD-L44S / FD-WL48

Long sensing range of 0 to 7mm for seating confirmation. Sensing is even possible if absorption pads are present.

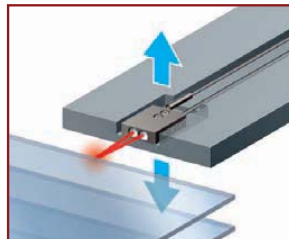
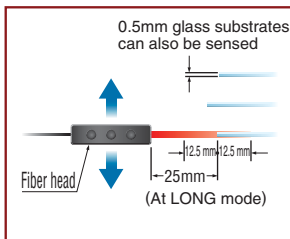

Technical Specifications

Applicable amplifiers:	FX-100/301/305/311/411 series red LED type
Sensing range (Note 1):	FD-L46 12.5 to 37.5mm (LONG mode) (Note 2) FD-L43 0 to 23mm (STD mode) FD-L44 0 to 7mm (LONG mode) (Note 3) FD-L44S 0 to 4.5mm (LONG mode) (Note 4) FD-L45 0 to 36mm (LONG mode) (Note 5) FD-WL48 0.5 to 7.5mm (LONG mode) (Note 6)
Allowable bending radius:	FD-L46 R25mm or more, FD-L45/FD-L43 R4mm or more FD-L44(S) R10mm or more, FD-WL48 R1mm or more
Fiber cable length:	FD-L46 4m (free-cut), FD-L43/44(S) 2m (free-cut) FD-L45 3m (free-cut), FD-WL48 1m (free-cut)

Notes: 1) The values for the FD-L46 are for R edge of glass substrate (100×100×0.7mm) for LCDs; the values for the FD-L43, FD-L44 and FD-L45 are for glass substrate (100×100×0.7mm) for LCD; the values for the FD-L44S are for silicon wafer (polished surfaces) and the values for the FD-WL48 are for white non-glossy paper (100×100mm).

- 2) 12 to 50mm for the FX-411 (U-LG mode).
- 3) 0 to 8.2mm for the FX-411 (U-LG mode).
- 4) 0 to 4.4mm for the FX-411 (U-LG mode).
- 5) 0 to 50mm for the FX-411 (U-LG mode).
- 6) FX-411 specifications are in U-LG mode.

FT/FD-V

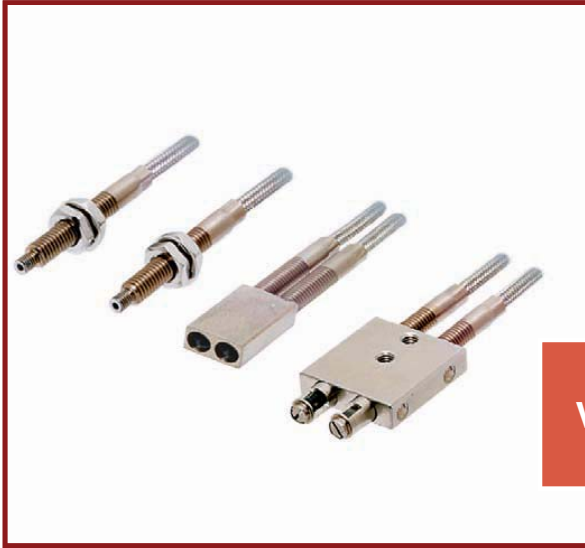

FT/FD-V

Vacuum resistant fiber

Features

Usable in high temperatures of 300°C and vacuum

Highly reliable sensing of objects is possible even after high-temperature processing used in FPD manufacturing.

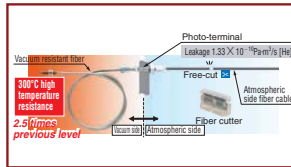

Highly durable

It can be bent durability of over 100,000 times (at R20mm).



Compact routing

We have realized a bending radius of R18mm.

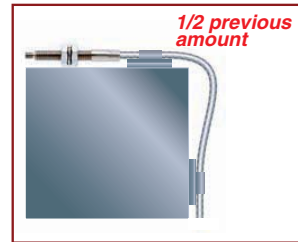

Technical Specifications

Applicable amplifiers:	FX-100/301/305/311/411 series
Sensing range (Note 1) (at LONG mode of red LED type):	FT-H30-M1V 250mm (Note 1) FD-H30-KZ1V 20 to 200mm (Note 2) FD-H30-L32V 0 to 8mm (Note 3)
Allowable bending radius:	FD-L46 R25mm or more, FD-L45/FD-L43 R4mm or more FD-L44(S) R10mm or more, FD-WL48 R1mm or more
Fiber cable length:	FD-L46 4m (free-cut), FD-L43/44(S) 2m (free-cut) FD-L45 3m (free-cut), FD-WL48 1m (free-cut)

- Notes: 1) 390mm for the FX-411 (U-LG mode).
2) 20 to 300mm for the FX-411 (U-LG mode).
3) 0 to 11mm for the FX-411 (U-LG mode).
4) Model n's. having the suffix '-S' are set model n's. When ordering, be sure to specify the vacuum resistant fiber, photo-terminals and atmospheric fibers set model n's.

EX-F70/F60



High-speed detection of even small liquid leaks

Features

Reliable detection

The unique effect of capillarity enables reliable detection of small leaks and viscous liquids.

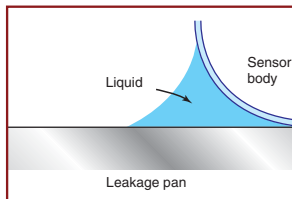

PFA enclosure gives excellent chemical resistance

Accurate sensing can be obtained even if there are leaks of chemicals such as sulfuric acid, hydrochloric acid or ammonia.

Safe design

If the sensor is installed incorrectly, the cable breaks or a sensor problem occurs, the same output is used as for a liquid leak. This guards against human error in setup that might occur during maintenance.

Compact, space-saving

The **EX-F70** series is a slim (10mm) side mounting sensor. The **EX-F60** series is compact at 26×19×9mm (W×H×D), so that it can be used even in narrow spaces.

Technical Specifications

	EX-F7m Water, Fluorinert™ (Note 1)
Sensing object:	EX-F6□Agent, such as sulfuric acid, hydrochloric acid, phosphoric acid or ammonia etc.
Supply voltage:	12 to 24VDC±10%
Output:	EX-F7□/F6□ NPN open-collector transistor EX-F7□/F6□-PNP open-collector transistor
Response time:	50ms or less
Emitting element:	Infrared LED (non-modulated)

Notes: 1) Fluorinert™ is the worldwide TradeMark of 3M.

FR-KV1

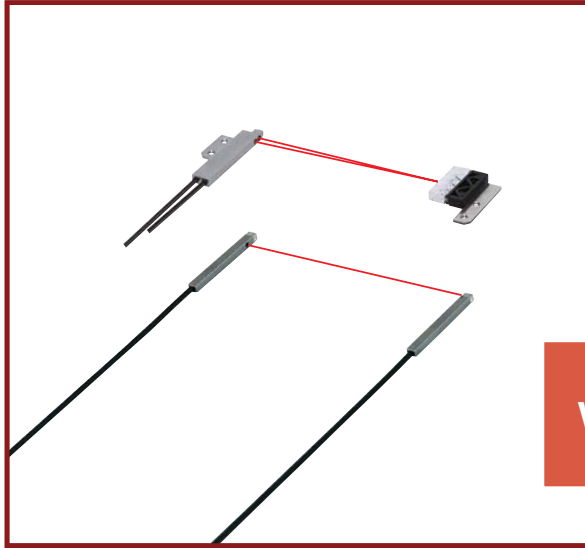

FR-KV1

Wafer mapping fiber

Features

Retroreflective type: new concept

A 2.0mm fiber head and an ultrathin 2.2mm reflector allow these sensors to be mounted even in thin robot hands. Since they are retroreflective type fibers, the amount of wiring needed can be reduced, and the robot hands require less processing and so can be kept strong. A heat-resistant type that can resist heat of +105°C is also available.

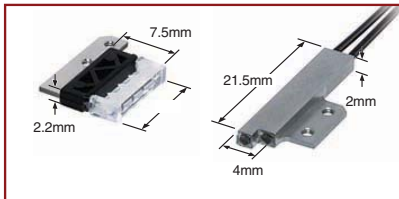

Thru-beam type: ultra compact size

The ultra compact size of 2×1.52×20mm (W×H×D) means that mounting is possible even in places such as robot hands where space is limited. Furthermore, a heat-resistant type that can resist heat of +105°C is also available.

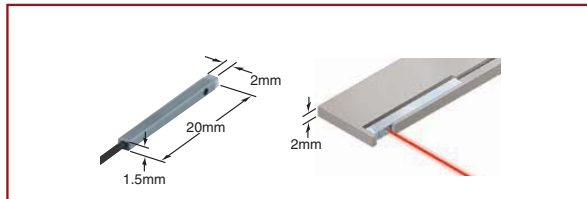

With the FT-KV1, the fiber can be embedded into a plate with a thickness of 2mm.

Technical Specifications

Applicable amplifiers:	FX-100/301/305/311/411 series
Sensing range: (at LONG mode of red LED type)	Retroreflective type 15 to 330mm (Note: thru-beam type 500mm)
Allowable bending radius:	R10mm or more
Fiber cable length:	2m (free-cut)



FD-F705

A new slim fiber sensor ideal for sensing chemical leaks

Features

Reliable detection

The unique effect of capillarity enables reliable detection of small leaks and viscous liquids.

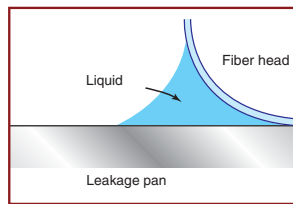

Compact, space-saving

This slim (10mm) side-mounting sensor is especially well suited for use in confined spaces.

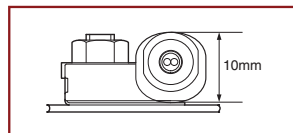

Ideal for chemicals and volatile materials

This fiber type sensor is safe to use with volatile materials (SEMI S2 compliant). The PFA (fluorine resin) fiber head makes it ideal for use with chemicals.

Technical Specifications

Applicable amplifiers:	FX-301-F, FX-301P-F
Sensing object:	Liquid
Fiber cable length:	5m (free-cut)
Protective tube length:	3m
Dimensions (W×H×D):	20×30×10mm

Notes: 1) Fluorinert™ is the worldwide TradeMark of 3M.

FT-F902

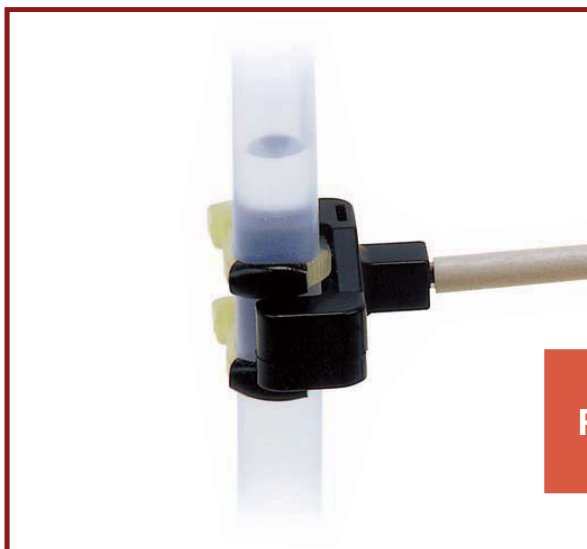

FT-F902

Reliably detect liquid in pipes

Features

Safe fiber type sensor

Because it is a fiber sensor, it is safe to use in dangerous areas where there is a risk of fire or explosion. It meets the stringent demands for higher safety levels placed by international standards including SEMI S2.

Easy to use and reliable detection

Even when shape and thickness of the pipe vary, this sensor uses a method where the beam axis follows the diameter of the pipe, and so, when compared to conventional methods, the shape and thickness of the pipe have no influence on the performance of this sensor.

Reliable detection not affected by bubbles or droplets

Problems encountered by conventional pipe-mountable sensors, such as bubbles, droplets or liquid leakage, have been solved using the latest optical fiber techniques.

Worry-free design that doesn't overlook liquid-absent condition and sensor malfunction

When liquid is present in the pipe, the lens effect of the liquid condenses the beam so that the sensor is in beam receiving condition.

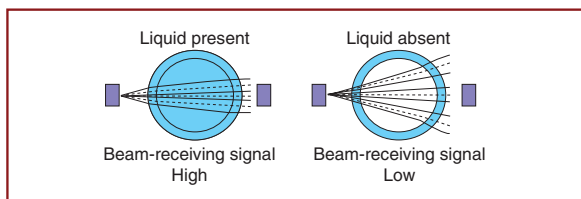

Technical Specifications

Applicable amplifiers:	FX-301-F, FX-301P-F
Sensing object:	Liquid
Applicable pipe diameter:	Outer dia. \varnothing 3.0 to \varnothing 10.0mm
Fiber cable length:	2m (free-cut)
Protective tube length:	1m
Dimensions (W×H×D):	23×17×20mm



M18-L

Standard: M18-L series

Features

Great lineup of 48 models

The M18-L series offers all optical functions in an M18 housing. The visible laser light spot makes the sensor simple to align. It is easy to install and requires little space due to its ultra-compact size.

- Available types: thru-beam laser sensor up to 60m, retroreflective type up to 16m, diffuse reflective type up to 350mm
- Complete range of optic functions, laser class 1
- Flat plastic tubular housing for improved versatility, or metal cylindrical housing
- Cable or M12 connection
- NPN or PNP
- Radial and axial versions

Typical Applications

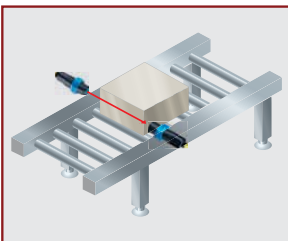

Packaging

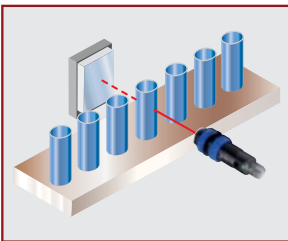

Precise object detection

Technical Specifications

NPN-Output	M18-LT5000-[R]-[M/P]-[J]	M18-LT6000-[A]-[M/P]-[J]	M18-LP0900-[R]-[M/P]-[J]	M18-LP1600-[A]-[M/P]-[J]
PNP-Output	M18-LT5000-[R]-[M/P]-PN-[J]	M18-LT6000-[A]-[M/P]-PN-[J]	M18-LP0900-[R]-[M/P]-PN-[J]	M18-LP1600-[A]-[M/P]-PN-[J]
Sensor type	Thru-beam		Retroreflective	
	Radial	Axial	Radial	Axial
Maximum operation distance	50m	60m	9m	16m
Sensing range	0 to 50m	0 to 60m	0.1 to 9m	0.1 to 16m
Sensing object	Metal, black			
	Ø 10mm		Ø 5mm	
Detectable target	Opaque		Opaque, translucent	
Hysteresis	-			
Response time	333µs			
Output	Max. 100mA			
Emitting element	Red semiconductor laser, 650nm (class 1)			
Current consumption without load	Emitter: max. 35mA		Max. 35mA	
	Receiver: max. 30mA			
Material	Metal version: nickel-plated brass			
	Plastic version: PBT			
	Lens: PMMA			
Protection	IP67			
Dimensions (H×W×D)	Cable type: M18×89mm	Cable type: M18×77mm	Cable type: M18×89mm	Cable type: M18×77mm
	Connector type: M18×93.5mm	Connector type: M18×81.5mm	Connector type: M18×93.5mm	Connector type: M18×81.5mm
Connection	Cable 2m or M12 connector			
Supply voltage	10 to 30VDC			
Ambient temperature	Operation: -10 to +50°C, storage: -25 to +70°C			
Weight	Cable type: Emitter and receiver each approx. 75g		Cable type: approx. 75g (plastic version) or approx. 110g (metal version)	
	Connector type: Emitter and receiver each approx. 25g		Connector type: Approx. 25g (plastic version) or approx. 60g (metal type)	
[R] = Radial • [A] = Axial [P] = Plastic [M] = Metal • [PN] = PNP [J] = M12 connector				

*Reflector not included

M18-L



Typical Applications

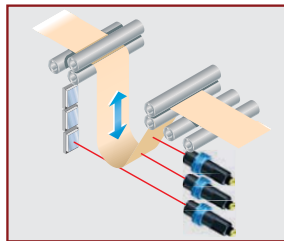

Control of sag

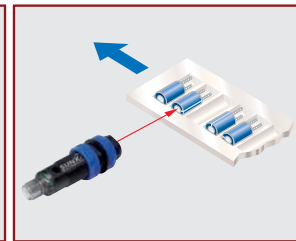

Detection of capacitors

Technical Specifications

NPN-output	M18-LD0025-R-[M/P]-[J]	M18-LD0035-A-[M/P]-[J]
PNP output	M18-LD0025-R-[M/P]-PN-[J]	M18-LD0035-A-[M/P]-PN-[J]
Sensor type	Reflective	
	Radial	Axial
Maximum operation distance	250mm	350mm
Sensing range	0 to 250mm	0 to 350mm
Spot diameter	0.3mm at 50mm	
Sensing object	Paper, white	
	100×100mm	200×200mm
Detectable target	Opaque, translucent	
Hysteresis	<1%	
Response time	333µs	
Output	Max. 100mA	
Emitting element	Red semiconductor laser, 650nm (class 1)	
Current consumption without load	Max. 35mA	
Material	Metal version: nickel-plated brass Plastic version: PBT Lens: PMMA	
Protection	IP67	
Dimensions (Ø × L)	M18 × 81.5mm	
Connection	Cable 2m or M12 connector	
Supply voltage	10 to 30VDC	
Ambient temperature	Operation: -10 to +50°C, storage: -25 to +70°C	
Weight	Cable type: approx. 75g (plastic version), approx. 110g (metal version) Connector type: approx. 25g (plastic version), approx. 60g (metal version)	
• [R] = Radial • [A] = Axial • [P] = Plastic • [M] = Metal • [PN] = PNP • [J] = M12 connector		

Options

Cables

UZZ81220	UZZ81221	UZZ81250	UZZ81251
2m straight	2m elbow	5m straight	5m elbow

Mounting brackets

M18L-ST20	M18-SPM

Reflector

M18-RF48



LC-100

Digital laser sensor

Features

Multifunction optoelectronic sensors

The **LC100 series** with a standard 50×50×15mm compact housing, offers all the most advanced optic functions including safety class 1 laser emission. This series offers versions with cable or M12 connection that can be rotated for either straight or right-angle positions. All versions have NPN or PNP output and standard configuration conforming to the EN 60947-5-2 standard. 16 types of LC100 are available.

Available in 4 versions

Laser through-beam

- Visible class 1 laser red light emission (typ. 650nm)
- Operating distance up to 60m with highest excess gain
- Resolution better than 6mm at 0.5m and 10mm over 2m
- Very high switching frequency up to 1.5kHz
- Double NO-NC output with NPN or PNP version
- Text input
- Plastic housing with compact dimensions 50×50×15mm

Laser polarized retroreflective

- Visible class 1 laser red light emission (typ. 650nm)
- Operating distance up to 20m
- Resolution better than 10mm
- Trimmer setting for fine sensitivity adjustment
- Very high switching frequency up to 2kHz
- Double NO-NC output with NPN or PNP version
- Plastic housing with compact dimensions 50×50×15mm

Diffuse reflective

- Visible class 1 laser red light emission (typ. 650nm)
- Operating distance 0 to 60cm
- Resolution approx. 0.2mm at 15cm
- Trimmer setting for fine sensitivity adjustment
- Very high switching frequency up to 2kHz
- Double NO-NC output with NPN or PNP version
- Plastic housing with compact dimensions 50×50×15mm

Background suppression

- Visible class 1 laser red light emission (typ. 650nm)
- Operating distance 5 to 10cm
- Resolution approx. 0.5mm at 6cm
- Teach-in setting
- Double NO-NC output with NPN or PNP version
- External teach-in
- Plastic housing with compact dimensions 50×50×15mm

Typical Applications

Positioning of printed circuit boards

Electronic industry

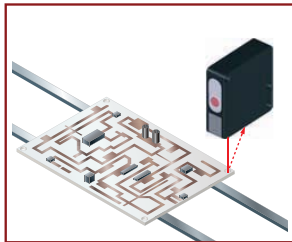

Detection of refrigerators boards

Packaging industry

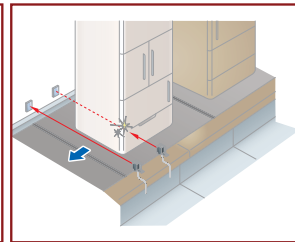

Detection of automobiles on conveyers

Automotive industry

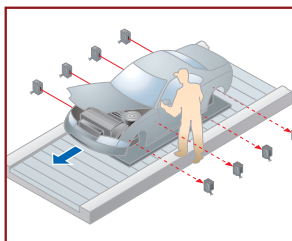



LC-100 Technical Specifications

NPN-Output	LC-100-TL6000-A-P-[J]	LC-100-PL2000-A-P-[J]	LC-100-DL0060-A-P-[J]	LC-100-BL0010-A-P-[J]
PNP-Output	LC-100-TL6000-A-P-PN-[J]	LC-100-PL2000-A-P-PN-[J]	LC-100-DL0060-A-P-PN-[J]	LC-100-BL0010-A-P-PN-[J]
Sensor type	Thru-beam	Retroreflective	Diffuse reflective	Diffuse reflective with BGS
Maximum operation distance	60m	20m	600mm	100mm
Sensing range	0 to 60m	0.1 to 20m	0 to 600mm	50 to 100mm
Sensing object	Metal, black		Paper, white	
	Ø 6mm		200 x 200mm	100 x 100mm
Detectable target	Opaque	Opaque, translucent	Opaque, transparent	
Hysteresis	-	-	<1%	
Response time	Approx. 333µs	Approx. 250µs		500µs
Output	Max. 100mA			
Emitting element	Red semiconductor laser, 650nm (Class 1)			
Current consumption without load	Emitter: max. 35mA Receiver: max. 35mA	Max. 35mA		Max. 60mA
Material	Enclosure: Plastic			
Protection	IP67			
Dimensions (H×W×D)	Cable type: approx. 50×50×15mm Connector type: approx. 50×66×15mm			
Connection	Cable 2m or M12 connector			
Supply voltage	10 to 30V DC			
Ambient temperature	Operation: -10 to +50°C, storage: -25 to +70°C			
Weight	Cable type: approx. 90g Connector type: approx. 40g			
[PN] = PNP • [J] = M12 connector				

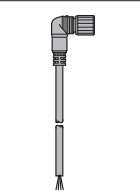

*Reflector not included

Options

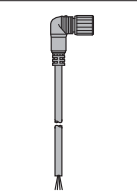
Cables

UZZ81220	UZZ81221	UZZ81250	UZZ81251
2m straight	2m elbow	5m straight	5m elbow
			

Mounting brackets

LC1-ST60	LC1-ST26	LC10-ST62
		

Reflector

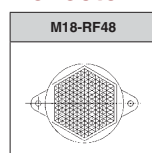



LC-120

High-performance sensors

Features

Maximum performance in compact housing

The **LC120 series** comes in a 50×50×18mm compact plastic housing and offers the maximum performance of optic detection functions for industrial automation.

Furthermore, versions with visible red laser emission are available with 50–350mm background suppression and polarized retroreflex reaching more than 20m.

These laser sensors are characterized by a very small light spot as well as a low response time that guarantee excellent detection repeatability, even of very small objects or movements.

- High-resolution sensors with LED or laser emission
- Background suppression models ranging up to 350mm
- Polarized retroreflex with operating distance of up to 20m
- Plastic housing with compact dimensions of 50×50×18mm
- NPN or PNP double output with standard NO-NC
- Visible class 2 laser red light emission (typ. 658nm)
- Very fast response time less than 200µs
- Very high switching frequency of up to 2.5kHz

Typical Applications

Foil detection

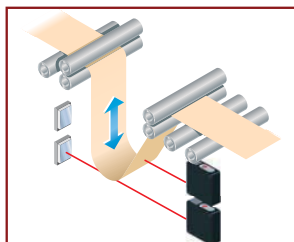

Pharmaceutical industry

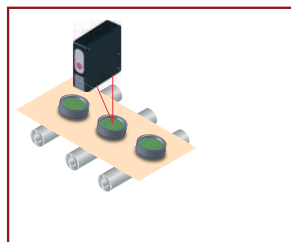



LC-120 Technical Specifications

NPN-Output	LC-120-PL2000-A-P-J	LC-120-BL0015-A-P-J	LC-120-BL0035-A-P-J
PNP-Output	LC-120-PL2000-A-P-PN-J	LC-120-BL0015-A-P-PN-J	LC-120-BL0035-A-P-PN-J
Sensor type	Retroreflective	Reflective with BGS	
Maximum operation distance	20m	150mm	350mm
Sensing range	0.3 to 20m	30 to 150mm	50 to 350mm
Spot diameter	Ø 0.5mm (at 0.5m)	0.2mm (at 60mm)	0.4mm (at 150mm)
Sensing object	Metal, black Opaque, translucent	Paper, white Opaque	
	Ø 6mm	100 x 100mm	
Detectable target	Opaque		
Hysteresis	—	<1%	
Response time	200µs	140µs	200µs
Output	Max. 100mA		
Emitting element	Red semiconductor laser, 645 to 665nm (Class 2)		
Current consumption without load	Max. 30mA		
Material	Enclosure: Plastic		
Protection	IP67		
Dimensions (H×W×D)	Connector type: approx. 50×66×18mm		
Connection	M12 connector		
Supply voltage	10 to 30V DC		
Ambient temperature	Operation: -10 to +50°C, storage: -25 to +70°C		
Weight	Approx. 40g		
[PN] = PNP • [J] = M12 connector			

*Reflector not included

Options

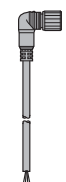
Cables

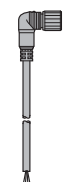
UZZ81220	UZZ81221	UZZ81250	UZZ81251
2m straight	2m elbow	5m straight	5m elbow
			

Mounting brackets

LC12-ST50	LC1-ST60	LC1-ST26
		

Reflector

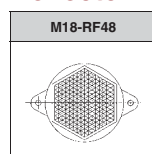



EX-L200

World's smallest laser sensor with built-in amplifier

Features

Minute object sensing type EX-L211

The beam is purposely widened to have a lower beam density and little beam spread so that when detecting minute objects, even a slight change in the light received intensity will not be missed.

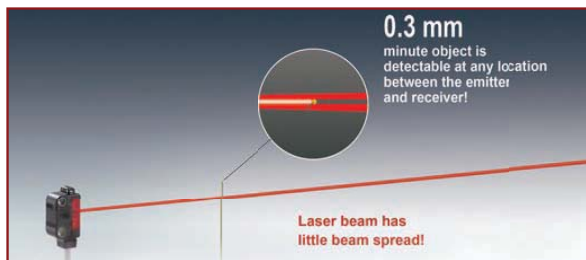

Long range sensing type EX-L212

A long range detection of 3m is achieved. High precision detection with minimum beam spread is possible even in a long range.

Environmental resistance

Strong against water and dust with protection structure IP67

The sensor can be used even in environments where water or dust is present.



Easy alignment

Beam alignment is easy

Beam alignment is carried out by looking at the red spot reflected on the beam alignment screen to match with the actual object. The optimum position can be understood at a glance by looking at the beam alignment screen and stability indicator (green).

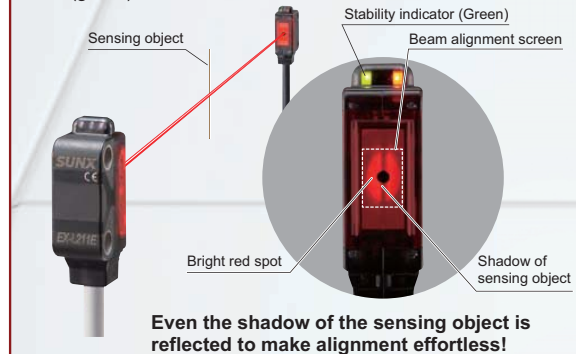

EX-L200 Typical Applications

Detecting ICs that are out of position in multiple palettes



Detecting tip of very thin pipe

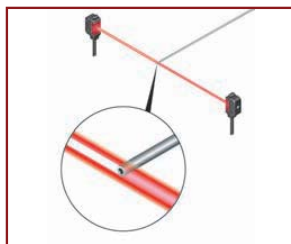

Detecting objects from an opening

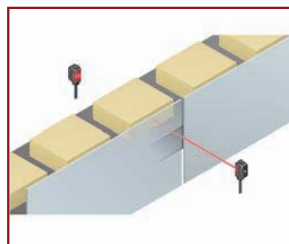

Technical Specifications

NPN output PNP output	EX-L211 EX-L211-P	EX-L212 EX-L212-P
Sensor type	Thru-beam Minute object sensing Long range sensing	
Maximum operation distance	1m	3m
Sensing range	0 to 1m	0 to 3m
Spot diameter (approx.)	6x4mm at 1m	8x5.5mm at 1m
Sensing object	Opaque Ø 2mm or more Ø 3mm or more	
Response time	0.5ms or less	
Output	Max. 100mA	
Emitting element	Red laser diode, 655nm (class 1)	
Current consumption without load	Ermittler: max. 10mA Receiver: max. 10mA	
Material	Body: PBT Front cover: Acrylic Lens: Glas	
Protection	IP67	
Dimension (HxWxD)	25.9x8.2x12mm	
Connection	Cable 2m	
Supply voltage ambient temperature	10 to 30VDC Operation: -10 to +55°C, Storage: -30 to +70°C	
Weight	Approx. 90g	



LS

User-friendly, advanced high precision laser sensing!

Features

4 types of identically sized sensor heads available

They are approximately the same size as general purpose photoelectric sensors, and the mounting method is identical.

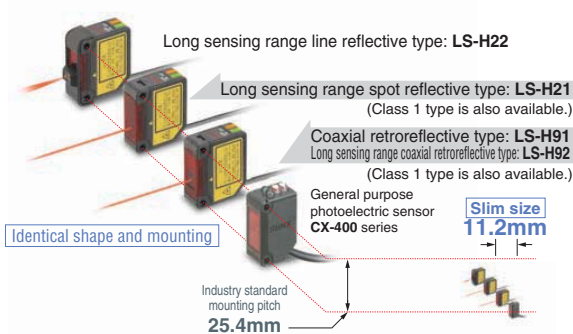

Accurately senses the minutest variations

When sensing at close range or when the target objects are transparent or minute, adjust the sensor receiving objects sensitivity to one of 3 levels for the optimal setting. In addition, changing the receiving sensitivity will not affect the response time.

Easy setting, dual display

Equipped with 2 large 4-digit digital displays. While checking the current light-receiving amount (red display), the optimal threshold value (green display) can be set easily.



Coaxial reflective type with a long sensing range of 30m

The introduction of the LS-H92 long sensing range coaxial reflective type sensor means that even longer sensing ranges are now possible.

Spot size adjustment

The long sensing range spot reflective type and long sensing range line reflective type have a built-in spot-size adjuster that enables spot size adjustment according to the object for optimal setting.



Wiring and space savings

The quick-connection cables enable reductions in wiring (connector type). The connections and man hours for the intermediate terminal block setup can be reduced and valuable space saved. Also, LS series amplifiers can be connected side-by-side with FX-300 series fiber sensors.



LS

Interference prevention function

The automatic interference prevention function protects against interference among up to 4 sensors.

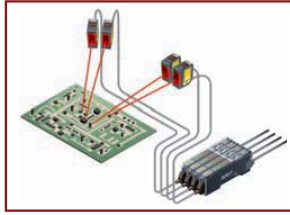

Emission halt function

Using the emission halt function, the laser beam can be stopped via external input, e.g. when a spot appears within the visual range of an image processor.

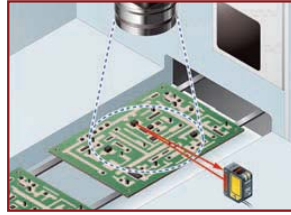

External teaching function

Teaching can be conveniently performed externally for laser sensors installed inside a device.

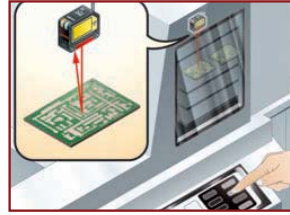

Typical Applications

IC pin check from remote position

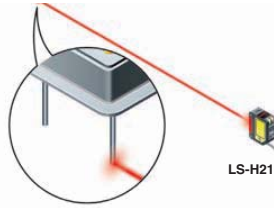

Checking protrusion of glass substrate



Technical Specifications

Sensor heads

Type	Coaxial retroreflective		Diffuse reflective	
		Long sensing range type	Long sensing range spot reflective	Long sensing range line reflective
Model no. (Note 1)	LS-H91(F) (-A)(Note 2)	LS-H92(F)	LS-H21(F) (-A)(Note 2)	LS-H22(F) (Note 3)
Sensing range	0.1 to 7m (U-LG) 0.1 to 5m (STD) 0.1 to 3m (FAST/H-SP)	0.2 to 30m (U-LG) 0.2 to 20m (STD) 0.2 to 10m (FAST/H-SP)	30 to 1000mm (U-LG) 30 to 500mm (STD) 30 to 300mm (FAST/H-SP)	30 to 1000mm (U-LG) 30 to 500mm (STD) 30 to 300mm (FAST/H-SP)
Ambient temperature	-10 to +55°C			
Emitting element	Red semiconductor laser, Class 2 (LS-HM: IEC/JIS/GB, LS-HMF: FDA/IEC/JIS) [LS-H91(F)-A, LS-H21(F)-A: Class 1] [Max. output: 3mW or less (LS-H91(F)-A, LS-H21(F)-A: 1 mW or less), Peak emission wavelength: 655nm]			
Dimensions (W×H×D)	11.2×31×25mm			

- Notes: 1) LS-H□ conforms to IEC/JIS/GB standards.
LS-H□F conforms to FDA/IEC/JIS standards.
2) LS-H91(F)-A, LS-H21(F)-A: Class 1 type.
3) LS-H22(F) is the set model no. for LS-H21(F) long sensing range spot reflective type sensor head combined with the LS-MR1 lens attachment for line reflective.
LS-H21(F) appears on the sensor itself.

Amplifiers

Type	Connector (Note)	Cable
Model no.	NPN output	LS-401
	PNP output	LS-401P
Supply voltage	12 to 24VDC ±10%	
Output (Output 1, Output 2)	NPN output type: NPN open-collector transistor PNP output type: PNP open-collector transistor	
Output operation	Selectable either Light-ON or Dark-ON, with jog switch	
Response time	80µs or less (H-SP), 150µs or less (FAST), 500µs or less (STD), 4ms or less (U-LG), selectable with jog switch	
Sensitivity setting	Normal mode: 2-level teaching/limit teaching/full auto teaching/manual adjustment Window comparator mode: teaching (1-level, 2-level, 3-level)/manual adjustment Hysteresis mode: teaching (1-level, 2-level, 3-level)/manual adjustment Differential mode: 5-level settings	
Digital display	4 digit (green) + 4 digit (red) LED display	
Automatic interference prevention function	Incorporated [up to four sets of sensor heads can be mounted close together (however, disabled when in H-SP mode)]	
Ambient temperature	-10 to +55°C (if 4 to 7 units are mounted close together: -10 to +50°C if 8 to 16 units are mounted close together: -10 to +45°C)	
Dimensions (W×H×D)	10×30×75mm	

Notes: The cable for amplifier connection is not supplied as an accessory with the connector type amplifier. Make sure to use the optional quick-connection cable listed below.

- Main cable (4-core): CN-74-C1 (cable length 1m), CN-74-C2 (cable length 2m)
CN-74-C5 (cable length 5m)
Sub cable (2-core): CN-72-C1 (cable length 1m), CN-72-C2 (cable length 2m)
CN-72-C5 (cable length 5m)

Sensing range:
LS-H91(F)-A 0.1 to 5m (U-LG), 0.1 to 3m (STD), 0.1 to 1m (FAST/H-SP)
LS-H21(F)-A 30 to 500mm (U-LG), 30 to 250mm (STD), 30 to 150mm (FAST/H-SP)



LX-100

Introducing the 3-LED mark sensor

Features

Equipped with 3 LEDs: red, green and blue

To detect any marking, this sensor is equipped with red, green and blue LED light emitting elements all in one. In addition, it uses a coaxial reflective optics system and realizes high precision sensing when used with a 1/4000 resolution 12-bit A/D converter.



2 selectable sensing modes for any application

Mark mode: This sensing mode automatically selects a single color from the 3 R-G-B LEDs to realize an ultra quick 45µs response time. The automatic optimal LED selection function automatically selects the LED that is most suitable for the sensing. This function is perfect for ultra quick sensing.

Color mode: All 3 R-G-B LEDs light up and high precision mark color discrimination occurs using the R-G-B reflective light ratio. This function enables effective detection of films with patterns around the areas of the mark.

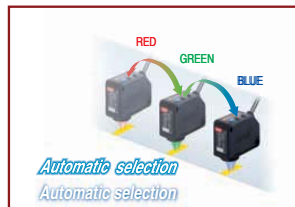

Even beginners can quickly master MODE NAVI operation

The sensor's basic operations are represented by 6 indicator lamps (MODE NAVI). The user can check what mode the sensor is presently in with a quick glance rendering operation simple.

Sensing status digitally controllable

The sensing status, displayed numerically, can be verified at a glance. Also, the sensor settings for each type of packing film can be digitally indicated.

Direct codes enable settings verification at a glance

The settings for the LX-100 series sensors are displayed using a 4-digit direct code. Direct codes enable easy settings verification and maintenance by phone.

Super simple teaching

Teaching (setting the threshold value) is simple, even in 'Mark Mode' or 'Color Mode'. In addition, because teaching via an operation panel or other external input device is also possible, models can be easily interchanged.

Compact design for significant space savings

High precision sensing and multiple functions are provided in a compact 57×24×35mm (W×D×H) body. Cable and plug-in connector types are available depending on the equipment used. These sensors can be easily integrated into already existing systems.

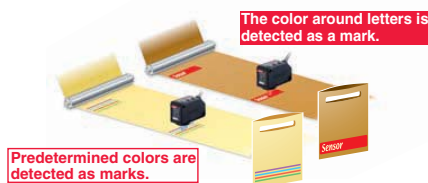

LX-100 Typical Applications

Tube positioning

Detects printed marks to align tubes

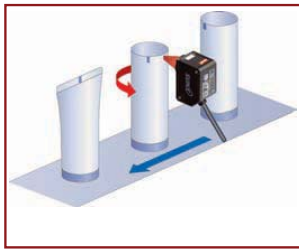

Mark detection

Mark detection of packaging film

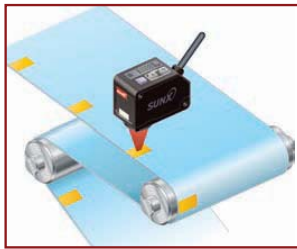

Technical Specifications

Type	Cable	Plug-in connector
Model. no.	NPN output	LX-101
	PNP output	LX-101-P
Sensing range	10 ±3mm	
Supply voltage	12 to 24VDC ±10%	
Output	NPN output type: NPN open-collector transistor PNP output type: PNP open-collector transistor	
Output operation	Mark mode: Light-ON/Dark-ON (auto-setting on teaching) Color mode: Consistent-ON/Inconsistent-ON (Setting on teaching)	
Response time	Mark mode: 45µs or less; color mode: 150µs or less	
Sensitivity setting	Mark mode: 2-level teaching/full-auto teaching; Color mode: 1-level teaching	
Protection	IP67 (IEC)	
Ambient temperature	-10 to +55°C	
Emitting element	Combined Red/Green/Blue LEDs (Peak emission wave length: 640nm/525nm/470nm)	
Dimensions (W×H×D)	71.5×24×35mm	

Note: Mounting cable is not supplied with the plug-in connector type. Please order separately.

Options

Cables

UZZ81220	UZZ81221	UZZ81250	UZZ81251
2m straight	2m elbow	5m straight	5m elbow



CX-400

A full lineup of world standard photoelectric sensors

Features

Great lineup of 116 models

The CX-400 series has a high level of basic functionality and excellent cost performance. Moreover, a wide number of variations means that there is sure to be a sensor that fits your needs.

Compact size

The sensors are compact in size at 11.2×31×20mm (W×H×D). The mounting pitch is also at the world standard size of 25.4mm (1inch).

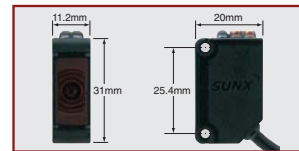

Type	Sensing range
CX-412□ Thru-beam (long sensing range)	15m
CX-411□ Thru-beam	10m
CX-493□ Retroreflective (long sensing range)	5m
CX-491□ Retroreflective (with polarizing filters)	3m
CX-482□ Retroreflective (transparent object sensing)	0.1 to 2m
CX-481□ Retroreflective (transparent object sensing)	50 to 500mm
CX-422□ Diffuse reflective (800mm type)	800mm
CX-421□ Diffuse reflective (300mm type)	300mm
CX-424□ Diffuse reflective (100mm type)	100mm
CX-423□ Diffuse reflective (narrow-view)	70 to 200mm
CX-442□ Adjustable range reflective	20 to 300mm
CX-444□ Adjustable range reflective	15 to 100mm
CX-443□ Adjustable range reflective	2 to 50mm
CX-441□ Adjustable range reflective (small spot)	2 to 50mm

Output	NPN, PNP
Connecting method (Note 1)	Cable type, M8 plug-in connector type, M12 pigtailed type
Cable length of cable type (Note 2)	0.5m, 2m, 5m

Notes: 1) Only the cable type and M8 plug-in connector type are available for the adjustable range reflective type.
 2) Only the 2m cable length type (standard) is available for the adjustable range reflective type.

Less processing

M8 plug-in connector type and M12 pigtailed type are available. This contributes to less time spent setting up. In addition, cable types are available with cable lengths of 0.5m, 2m and 5m. This results in less waste.

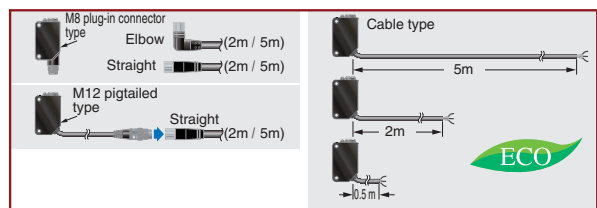

Less power consumed

The CX-400 series sensors achieve a maximum of approx. 55% of the power consumption of conventional sensors. This contributes to preserving the environment.

Less resources used

Based on environmental considerations, simplified packaging is used in order to reduce waste.

In addition, the bag is made of polyethylene, which produces no toxic gases even when burned.

CX-400

Strong against oil and coolant liquids

CX-41□/42□/49□

The lens material for the thru-beam type, retroreflective type (excluding the CX-48□) and the diffuse reflective type is made of a strong acrylic that resists the harmful effects of coolants. These sensors can be used with confidence even around metal processing machinery that disperses oil mists. The protection mechanism also conforms to IP67 (IEC).

Strong against ethanol

CX-44□/48□

A strong, ethanol-resistant polycarbonate is used for the front and display covers. Safe even for installing near food processing machinery that disperses ethanol-based detergents. The protection mechanism also conforms to IP67 (IEC).

Strong against interference

The interference prevention function allows two sensors to be mounted close together.

Typical Applications

Detecting car on conveyor line



Detecting transparent bottles

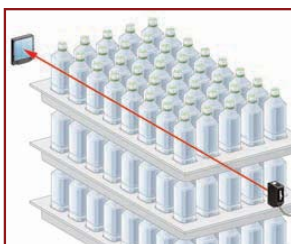

Detecting label

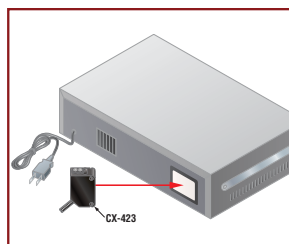

Thru-beam type CX-41□

Strong infrared beam

It realizes a 15m long-distance sensing range. Remarkable penetrating power enables applications such as package content detection.

Retroreflective type CX-49□

Strongest sensing range in its class

A long 5m sensing range is possible with the red LED type that is easy to align with the beam axis. Can be used for wide automatic door shutters.

Diffuse reflective type CX-42□

Beam axis alignment made easy

These sensors realize a high luminance red LED spot that provides bright visibility enabling the sensing position to be checked at a glance.

Because it has the small spot, approx. $\varnothing 2\text{mm}$, even the minutest object can be accurately detected.

CX-481□/48□

Introducing the transparent object sensing type sensor

Our unique optical system and transparent object sensing circuitry provide stable sensing of even thinner transparent objects than the conventional models.

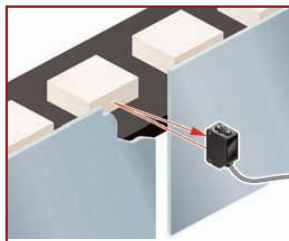

CX-441/443□

Can sense differences as small as 0.4mm, with hysteresis of 2% or less

An advanced optical system provides sensing performance that is approx. 2.5 times more precise than conventional models. Even ultra small differences of 0.4mm can be detected accurately.

CX-44□

Not affected by color

Both black and white objects can be sensed at almost the same distances. No adjuster control is needed, even when products of different colors are moving along the production line.

Sensing range difference is 1% or less between white non-glossy paper and non-glossy paper (gray) with lightness 5 at a setting distance of 50mm.

BGS/FGS functions make even the most challenging settings possible!

Background not present

When object and background are separated.



Background present

When object and background are close together.



When the object is glossy or uneven.

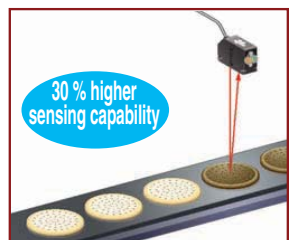
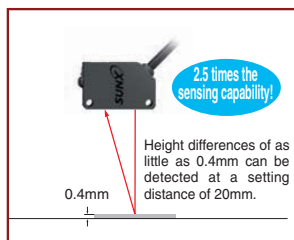

Technical Specifications

CX-400

Type		Thru-beam		Retroreflective				Diffuse reflective			
		Long sensing range		With polarizing filters	Long sensing range		For transparent object sensing				
Model. no.	NPN	CX-411	CX-412	CX-491	CX-493	CX-481	CX-482	CX-424	CX-421	CX-422	CX-423
	PNP	CX-411-P	CX-412-P	CX-491-P	CX-493-P	CX-481-P	CX-482-P	CX-424-P	CX-421-P	CX-422-P	CX-423-P
Sensing range		10m	15m	3m	5m	50 to 500mm	0.1 to 2m	100mm	300mm	800mm	70 to 200mm
Supply voltage		12 to 24VDC ±10%									
Output		NPN output type: NPN open-collector transistor, PNP output type: PNP open-collector transistor									
Output operation		Switchable either Light-ON or Dark-ON									
Response time		1ms or less									
Automatic interference prevention function		Two units of sensors can be mounted close together with interference prevention filters. (Sensing range: 5m)	-	Incorporated (two units of sensors can be mounted close together.)							
Protection		IP67 (IEC)									
Ambient temperature		-25 to +55°C									
Emitting element (modulated)		Red LED	Infrared LED	Red LED		Infrared LED				Red LED	

Note: 0.5m/5m cable length type (standard: 2m), M8 plug-in connector type, and M12 pigtailed type are available.





Type		Adjustable range reflective			
		Small spot			
Model. no.	NPN output	CX-441	CX-443	CX-444	CX-442
	PNP output	CX-441-P	CX-443-P	CX-444-P	CX-442-P
Adjustable range (Note 1)		20 to 50mm		20 to 100mm	40 to 300mm
Sensing range (with white non-glossy paper)		2 to 50mm		15 to 100mm	20 to 300mm
Supply voltage		12 to 24VDC ±10%			
Output		NPN output type: NPN open-collector transistor, PNP output type: PNP open-collector transistor			
Output operation		Switchable either Detection-ON or Detection-OFF			
Response time		1ms or less			
Sensing mode		BGS/FGS functions Switchable with wiring of sensing mode selection input			
Protection		IP67 (IEC)			
Ambient temperature		-25 to +55°C			
Emitting element		Red LED (modulated)			

Notes: 1) The adjustable range stands for the maximum sensing range which can be set with the distance adjuster. The sensor can detect an object at a distance of 2mm [CX-444(-P): 15mm, CX-442(-P): 20mm] or more.
2) M8 plug-in connector type is also available.



CX-400

Options

Cables for M8

UZZ80820	UZZ80821	UZZ80850	UZZ80851
2m straight	2m elbow	5m straight	5m elbow
			

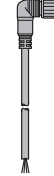
Cables for M12

UZZ81220	UZZ81221	UZZ81250	UZZ81251
2m straight	2m elbow	5m straight	5m elbow
			



NX5

Sensor world-wide usable

Multi-voltage

24 to 240VAC and 12 to 240VDC, suitable for supply voltages all over the world.

High reliability

The NX5 has IP66 protection. Moderate dust or water splashes do not affect it. The hermetically sealed output relay significantly increases its reliability.

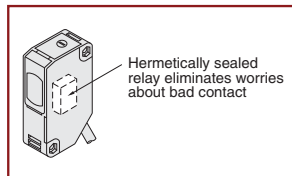

Interference prevention

Two sensors operate normally even when mounted close together (excluding the 30m thru-beam type sensor).

Long sensing range

Suitable for conveyor lines and parking lot applications.

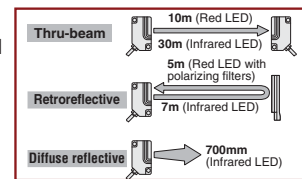

Typical Applications

Multistoried parking

Detects if the car is protruding from the elevator door.

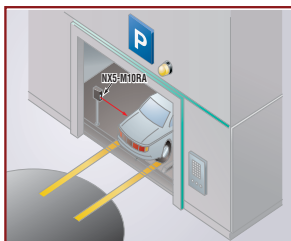

Golf driving range

The sensor detects the presence of a golf ball. The sensor is multi-voltage type so no DC power supply is needed.

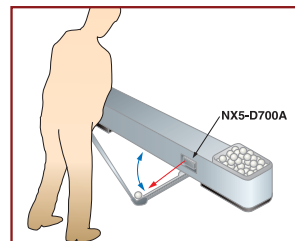

Arresting shutter closing

The long sensing range sensor with a visible red beam can be used to control the shutter operation at the gate of a factory.

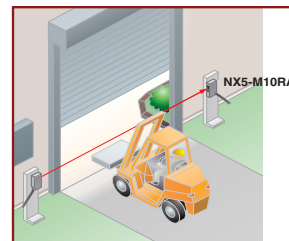

Arresting door closing

The sensor detects a person or an object and prevents the door from closing as long as its beam is interrupted.

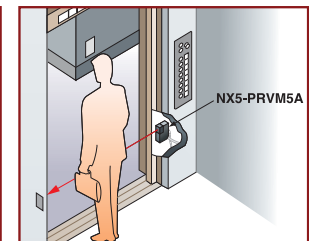

NX5

Technical Specifications

Item	Type	Thru-beam				Retroreflective				Diffuse reflective	
				Long sensing range		With polarizing filters		Long sensing range			
Model no.		NX5-M10RA	NX5-M10RB	NX5-M30A	NX5-M30B	NX5-PRVM5A	NX5-PRVM5B	NX5-RM7A	NX5-RM7B	NX5-D700A	NX5-D700B
Sensing range		10m		30m		0.1 to 5 m (Note 1)		0.1 to 7m (Note 1)		700mm (Note 2)	
Sensing object		∅20mm or more opaque object (Note 3)				∅50mm or more opaque, translucent or specular object (Note 1)		∅50mm or more opaque or translucent object (Note 1)		Opaque, translucent or transparent object	
Hysteresis		—									
Repeatability (perpendicular to sensing axis)		0.1mm or less		0.2mm or less						0.3mm or less	
Supply voltage		24 to 240VAC ±10%, or 12 to 240VDC ±10% Ripple P-P 10% or less									
Power consumption		Emitter: 1 VA or less Receiver: 2 VA or less		Emitter: 1.5VA or less Receiver: 2 VA or less		2VA or less					
Output		Relay contact 1c • Switching capacity: 250VAC 1A (resistive load) 30VDC 2A (resistive load) • Electrical life: 500,000 or more switching operations (switching frequency 3600 operations/hour) • Mechanical life: 100 million or more switching operations (switching frequency 36,000 operations/hour)									
Output operation		Light-ON	Dark-ON	Light-ON	Dark-ON	Light-ON	Dark-ON	Light-ON	Dark-ON	Light-ON	Dark-ON
Response time		10ms or less									
Operation indicator		Red LED (lights up when the output is ON)									
Stability indicator		Green LED (lights up under stable light received condition or stable dark condition)									
Power indicator		—		Red LED (lights up when the power is ON)		—				—	
Sensitivity adjuster		Continuously variable adjuster		—		Continuously variable adjuster		—		Continuously variable adjuster	
Automatic interference prevention function		Use optional interference prevention filters		—		Incorporated (two sensor units can be mounted close together.)					
Environmental resistance	Pollution degree	3 (industrial environment)									
	Protection	IP66 (IEC)									
	Ambient temperature	-20 to +55°C (no dew condensation or icing allowed)(Note 4); storage: -30 to +70°C									
	Ambient humidity	35 to 85% RH; storage: 35 to 85% RH									
	Ambient illuminance	Sunlight: 11,000 lx at the light-receiving face; incandescent light: 3500 lx at the light-receiving face									
	EMC	EN 50081-2, EN 50082-2, EN 61000-6-2									
	Voltage with standability	1500VAC for one min. between power supply and output terminals; 1000VAC for one min. between relay contact terminals									
	Insulation resistance	20MΩ, or more, with 500VDC megger between power supply and output terminals, and between relay contact terminals									
Vibration resistance	10 to 55Hz frequency, 1.5mm amplitude in X, Y and Z directions for two hours each										
Shock resistance	500m/s ² (50G approx.) in X, Y and Z directions for three times each										
Emitting element (modulated)		Red LED (modulated)		Infrared LED (modulated)		Red LED (modulated)		Infrared LED (modulated)			
Material		Enclosure: Polycarbonate; lens: polycarbonate; cover: polycarbonate; front cover (retroreflective type sensor only): acrylic									
Cable		0.3mm ² 5-core (thru-beam type emitter: 2-core) cable, 2m long									
Cable extension		Extension up to total 100m is possible with 0.3mm ² , or more, cable (thru-beam type: both emitter and receiver)									
Weight		Emitter: 100g approx. Receiver: 140g approx.		Emitter: 125g approx. Receiver: 140g approx.		140g approx.					
Accessory		Adjusting screwdriver: 1 pc		—		RF-230 (reflector): 1 pc. Adjusting screwdriver: 1 pc.		RF-230 (reflector): 1 pc.		Adjusting screwdriver: 1 pc.	

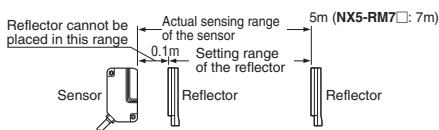

- Notes:**
- 1) The sensing range and the sensing object of the retroreflective type sensor is specified for the **RF-230** reflector. Further, the sensing range is the possible setting range for the reflector. The sensor can detect an object less than 0.1m away.
 - 2) The sensing range of the diffuse reflective type sensor is specified for white non-glossy paper (200×200m) as the object.
 - 3) If slit masks (optional) are fitted, an object as small as 3×6mm can be detected.
 - 4) In the event that the sensor is to be used at an ambient temperature of -15°C, or less, please contact our office.

CY

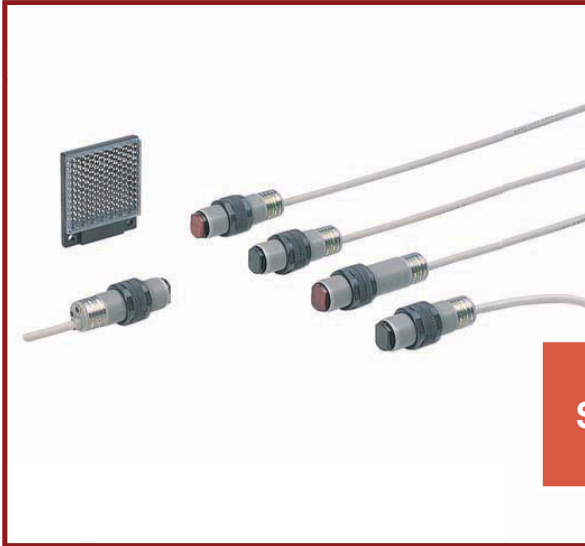

Simple mounting with M18 thread

Features

M18 thread

This sensor has an M18 thread on the enclosure, which is convenient for mounting.

Easy to replace

A pigtailed type sensor with M12 connector (CY-□-J) is easy to replace.

Wide product range

Supply voltage

- ① AC supply type (24 to 240 V AC)
- ② DC supply type (10 to 30 V DC)

Output

- ① NPN open-collector transistor
- ② PNP open-collector transistor
- ③ AC non-contact (thyristor) output

Connection

- ① Cable type
- ② Pigtailed type

A total of 32 models are available.

Environmentally robust

Both the sensor and connector have an IP67 degree of protection. In addition, it is resistant to vibration since it is filled with resin.



Typical Applications

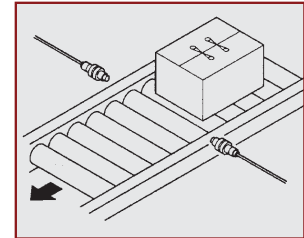

Object detection

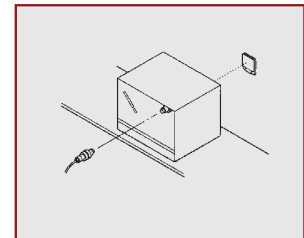

Position detection

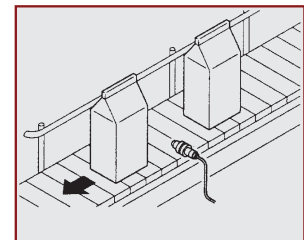

Object detection

CY Technical Specifications

AC supply type

Light ON	CY-11A (-J)	CY-17A (-J)	CY-19A (-J)	CY-12A (-J)
Dark ON	CY-11B (-J)	CY-17B (-J)	CY-19B (-J)	CY-12B (-J)
Sensor type	Thru-beam	Retroreflective	Retroreflective with polarization filter	Diffuse
Rated sensing distance	12m	3m	1.5m	0.12m
Standard detectable object	Metal, matt black			White drawing paper
	∅ ≥ 8mm	∅ ≥ 50mm		5 x 5cm
Detectable target	Opaque	Opaque, semitransparent		Opaque, transparent
Hysteresis	--	--	--	< 15% of measurement range
Response time	Max. 20ms			
Output thyristor	Min. 5mA, max. 200mA			
Emitting diode	Infrared LED		Red LED	Infrared LED
Rated current consumption without load	Transmitter: max. 1.5VA Receiver: max. 2.5V	Max. 2.7VA		
Housing material	Plastic			
Protection	IP67			
Physical size (∅xL)	M18 x 71mm			
Connection method	Cable 2m or M12 connector (-J)			
Operating voltage	24 - 240VAC (±10%)			
Usable ambient temp.	-25°C to +55°C			
Weight (approx.)	190g	100g		

Technical Specifications

DC supply type

NPN output	CY-21 (-J)	CY-27 (-J)	CY-29 (-J)	CY-22 (-J)
PNP output	CY-21-PN (-J)	CY-27-PN (-J)	CY-29-PN (-J)	CY-22-PN (-J)
Sensor type	Thru-beam	Retroreflective	Retroreflective with polarization filter	Diffuse
Rated sensing distance	12m	3m	1.5m	12cm
Standard detectable object	Metal, matt black			White drawing paper
	∅ ≥ 8mm	∅ ≥ 50mm		5 x 5cm
Detectable target	Opaque	Opaque, semitransparent		Opaque, transparent
Hysteresis	--	--	--	< 15% of measurement range
Response time	Max. 2ms			
Output transistor	Max. 100mA			
Emitting diode	Infrared LED		Red LED	Infrared LED
Rated current consumption without load	Transmitter: max. 20mA Receiver: max. 25mA	Max. 25mA		
Housing material	Plastic			
Protection	IP67			
Physical size (∅xL)	M18 x 56mm			
Connection method	Cable 2m or connector (-J)			
Operating voltage	10 - 30VDC (±10%)			
Usable ambient temp.	-25°C to +55°C			
Weight (approx.)	190g	100g		

M18



Photoelectric sensor basic line

Features

- Basic models available with axial or radial optics
- Versions with NPN or PNP output, cable or M12 connector
- Standard 3-wire connection configuration
- Selectable dark or light output
- Plastic or metal housing

Technical Specifications

Plastic PNP	M18-T120P-PN(-J)	M18-R020P-PN(-J)	M18-P015P-PN(-J)	M18-D003P-PN(-J)
Plastic NPN	M18-T120P(-J)	M18-R020P(-J)	M18-P015P(-J)	M18-D003P(-J)
Metal PNP	M18-T120M-PN(-J)	M18-R020M-PN(-J)	M18-P015M-PN(-J)	M18-D003M-PN(-J)
Metal NPN	M18-T120M(-J)	M18-R020M(-J)	M18-P015M(-J)	M18-D003M(-J)
Sensor type	Through-beam	Retroreflective	Retroreflective with polarizing filter	Reflective
Rated sensing distance	12m	2m	1.5m	30cm
Standard detectable object	Metal, black matt finish			
Detectable target	∅5mm or more, opaque object	∅35mm or more, opaque or transparent object	∅7.5mm or more, opaque or transparent object	∅5mm or more, opaque or transparent object
Hysteresis	-	-	-	≤ 15% of the measurement range
Response time	Max. 2ms	Max. 1ms		
Output transistor	Max. 100mA			
Emitting diode	Infrared LED		Red LED	Infrared LED
Current consumption without load	Emitter: max. 20mA Receiver: max. 25mA	Max. 30mA		
Housing material	Plastic/nickel-plated brass			
Protection	IP67			
Physical size (∅ x L)	M18×57mm			
Connection method	Cable 2m; plug connection (J)			
Operating voltage	10 to 30V DC (±10%)			
Usable ambient temperature	-25°C to +55°C			
Weight	Max. 210g	Max. 110g		

Typical Applications

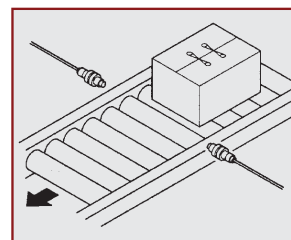

Object detection

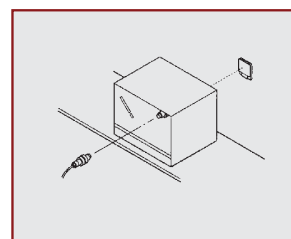

Position detection

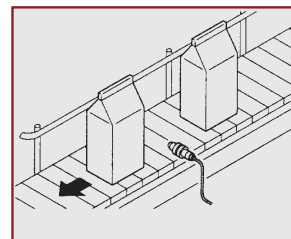

Object detection

EX-10



EX-10

The smallest: 3.5mm thick

Features

Freely mountable fingertip size

Freely mountable 10×14.5×3.5mm (W×H×D) size (thru-beam, front sensing type). Moreover, easy alignment is possible with the visible red LED beam source.

Long sensing range 1m: EX-19□

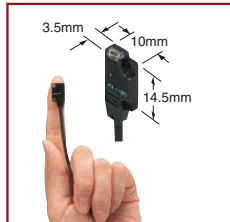

Typical Applications

Detecting the float for a flow meter

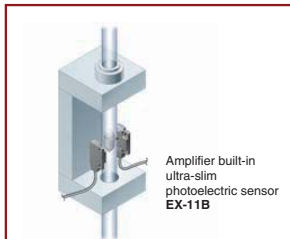

Seating confirmation of FOUNDRY OVERLAY PANEL (FOUP)

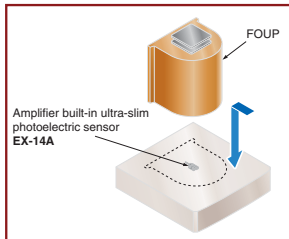

Detecting end of screw supply

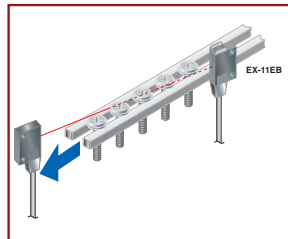

Sensing PCB rack

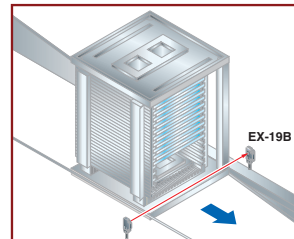

Technical Specifications

Type	Thru-beam						Convergent reflective	
Model. no.	EX-11A(-PN)	EX-11B(-PN)	EX-13A(-PN)	EX-13B(-PN)	EX-19A(-PN)	EX-19B(-PN)	EX-14A(-PN)	EX-14B(-PN)
Sensing range	150mm		500mm		1m		2 to 25mm (conv. point: 10mm)	
Min. sensing object	∅1mm opaque object		∅2mm opaque object				∅0.1mm copper wire (Setting distance: 10mm)	
Supply voltage	12 to 24VDC±10%							
Output	PNP / NPN open-collector transistor							
Output operation	Light-ON	Dark-ON	Light-ON	Dark-ON	Light-ON	Dark-ON	Light-ON	Dark-ON
Response time	0.5ms or less							
Protection	IP67 (IEC)							
Ambient temperature	-25 to +55°C							
Dimensions (W×H×D)	10×14.5×3.5mm						13×14.5×3.5mm	

Options

Slit mask available for EX-13□/19□

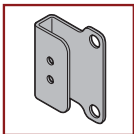

OS-EX10-12
OS-EX10-15

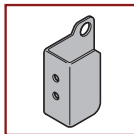

OS-EX10E-12

EX-20



EX-20

Miniature-sized and still mountable with M3 screws

Features

Long sensing range

The EX-20 series achieves long distance sensing [thru-beam type: 2m, retroreflective type: 200mm (when using the attached reflector), diffuse reflective type: 160mm], despite its miniature size. Hence, it is usable even on a wide conveyor.

Clear beam spot using red LED dot light source

The emission area of a dot light source is smaller than that of a conventional LED flat light source, and it is possible to design a high power, narrow beam. Since a red LED dot light source is used, the red beam spot is clearly visible even at a long distance so that alignment and confirmation of sensing position is easy.

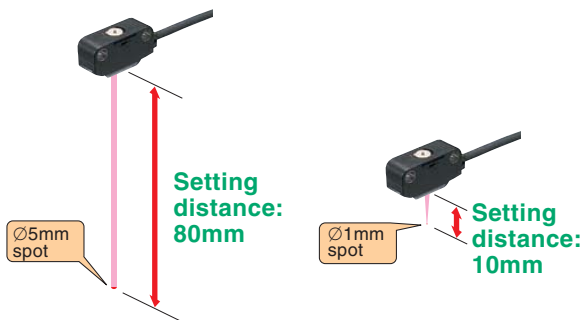

Typical Applications

Checking protrusion of wafer

The ultra compact photoelectric sensor EX-23 has a sufficiently long sensing range of 2m. Further, its visible red LED beam makes beam alignment very easy.

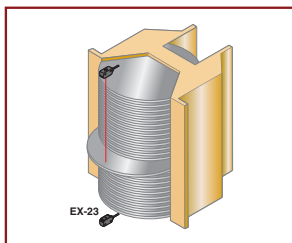

Detecting tape feeder cassette out of position

Ultra compact in size with an ample sensing range of 2m, ideal for monitoring tape feeder cassettes that are out of position.

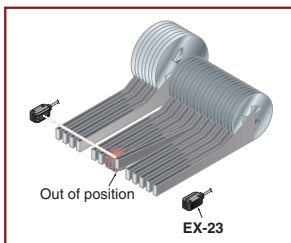

Detecting fill-up of parts in feeder

The sensor setting can be finely adjusted since a universal sensor mounting bracket, with which the height and the angle of the sensor can be freely adjusted, is available.

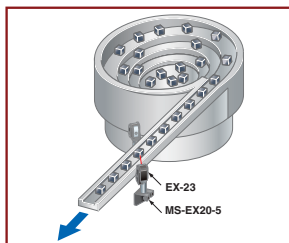

Technical Specifications

EX-20

Type		Thru-beam		Retroreflective	Diffuse reflective	Convergent reflective		Narrow-view reflective
		Front sensing	Side sensing	Side sensing	Side sensing	Diffuse beam	Small spot beam	Long distance spot beam
						Front sensing	Side sensing	Side sensing
Model. no.	Light-ON	EX-21A(-PN)	EX-23(-PN)	EX-29A(-PN)	EX-22A(-PN)	EX-24A(-PN)	EX-26A(-PN)	EX-28A(-PN)
	Dark-ON	EX-21B(-PN)		EX-29B(-PN)	EX-22B(-PN)	EX-24B(-PN)	EX-26B(-PN)	EX-28B(-PN)
Sensing range		1m	2m	30 to 200mm	5 to 160mm	2 to 25mm (Conv. point: 10mm)	6 to 14mm (Conv. point: 10mm)	45 to 115mm
Sensing object		Min. \varnothing 2.6mm opaque object	Min. \varnothing 3mm opaque object	\varnothing 15mm or more opaque or translucent object	Opaque, translucent or transparent object	Min. \varnothing 0.1mm copper wire (Setting distance: 10mm)		Opaque, translucent or transparent object
Supply voltage		12 to 24V DC \pm 10%						
Output		NPN output type: NPN open-collector transistor; PNP output type: PNP open-collector transistor						
Response time		0.5ms or less						
Protection		IP67 (IEC)						
Ambient temperature		-25 to +55°C						
Dimensions (W×H×D)		8.2×22×12.3mm						10×14.5×3.5mm (sensor head)

EX-30



EX-30

A new alternative to fiber sensors

Features

Can be installed in the same way as standard fibers

The EX-30 series can be screw-mounted (M4 for thru-beam type, M6 for reflective type) in the same way as standard fiber sensors. This means that they can be inserted into production lines in exactly the same way as conventional fiber sensors.

New design solves all weak points of fiber sensors

The EX-30 series solves all of the difficulties associated with fiber sensors, such as 'Difficulty finding a suitable place for the amplifier', 'Fragility of the fiber', 'Extra space needed because of difficulty in bending the fiber', 'The nuisance of having to use a protective tube to prevent fiber breakage'.

800mm thru-beam type available

The sensing range is 1.5 times greater than previous models! It also has a sensitivity adjuster to enable compatibility with a wide range of applications.

Typical Applications

Detecting quantity of labels in label magazine

Detects the remaining amount of labels by the thickness of the roll.

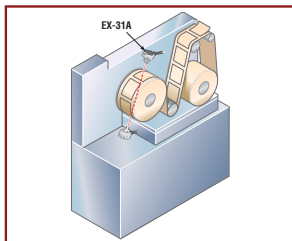

Detecting IC height

Detects whether ICs are accurately placed in IC trays.

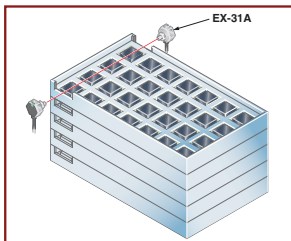

Resin bottle detection

The EX-32A threaded photoelectric sensor confirms the arrival of bottles.

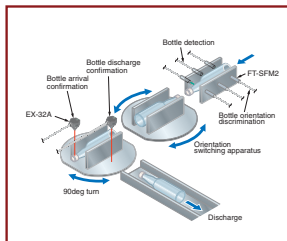

Technical Specifications

Type		Thru-beam			Diffuse reflective		
Model no.	NPN output	EX-31A	EX-31B	EX-33	EX-32A	EX-32B	
	PNP output	EX-31A-PN	EX-31B-PN	EX-33-PN	EX-32A-PN	EX-32B-PN	
Sensing range		500mm			800mm	50mm	
Sensing object		Min. \varnothing 2mm or more opaque object				Opaque, translucent or transparent object	
Supply voltage		12 to 24V DC \pm 10%					
Output		NPN output type: NPN open-collector transistor PNP output type: PNP open-collector transistor					
Output operation		Light-ON	Dark-ON	Variable (switching method)	Light-ON	Dark-ON	
Response time		0.5ms or less					
Protection		IP67 (IEC)					
Ambient temperature		-25 to +55°C					

Note: 5m cable length type (standard: 2m) is also available [excluding EX-33(-PN)].

PM



PM

Enables equipment miniaturization and quick construction

Features

Extremely compact

Ultra small type
PM-□24(-R) achieves an extremely compact size and can contribute to the miniaturization of your equipment.

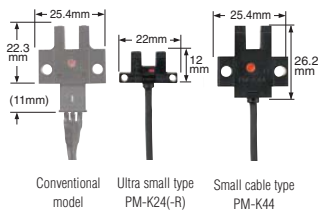

Quick fitting hook-up connector

Easy to maintain hook-up connector type models are available. Since only crimping with exclusive pliers needs to be done, cumbersome soldering or insulation is not required. Further, a connector attached cable (CN-14H-C1/C3) is also available.

Equipped with two independent outputs

All models are equipped with two independent outputs—Light-ON and Dark-ON. Hence, one model suffices even if the output is to be used differently.

Flexible cable type

Flexible cable is used, which allows repeated bending. It is suitable for use in the moving part of a robot arm.

Quick-connector connections with commercially-available connectors

The connector is built-in, allowing greater space savings. Commercially available general-purpose connectors can be used with some types for improved reliability.

Typical Applications

Sensing rotating bodies

By incorporating a slit in the rotating body, the origin point can be sensed.

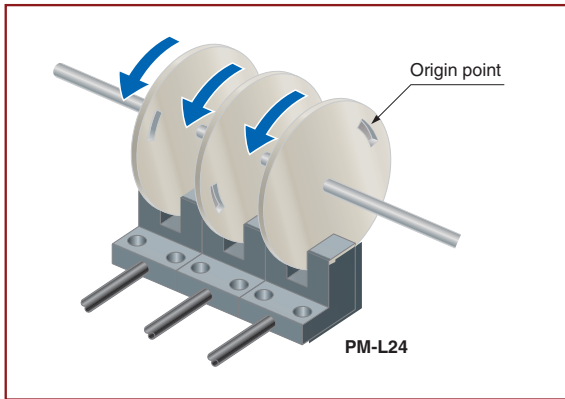

Determine the pallet position

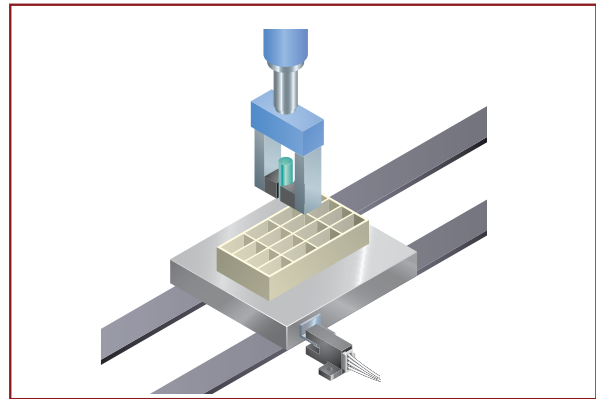

Technical Specifications

Type		Ultra small type	Small type		
		With cable	With cable	With connector	Built-in connector
Model no.	NPN output	PM-□24(-R) (Note)	PM-□44	PM-□54	PM-□64
	PNP output	PM-□24P	PM-□44P	PM-□54P	PM-□64P
Sensing range		5mm (fixed)			
Min. sensing object		0.821 × 1.8mm opaque object			
Repeatability		0.03mm or less	0.01mm or less		
Supply voltage		5 to 24VDC ±10%			
Output		NPN output type: NPN open-collector transistor PNP output type: PNP open-collector transistor			
Output operation		Incorporated with 2 outputs: Light-ON / Dark-ON			
Response time		Under light incident condition: 20μs or less Under light interrupted condition: 100μs or less (Response frequency: 1kHz or more)			
Emitting element		Infrared LED (non-modulated)			

Note: PM-□24-R is flexible cable type.
3m cable length type (standard: 1m) is also available (excluding flexible cable type and PNP output type).

Example: PM-K44
K = K-Type
L = L-Type
F = F-Type
R = R-Type
U = U-Type

Order Guide



Type	Appearance (mm in)	Sensing range	Model no. (Note)
Ultra-small	K type 	5 mm (fixed)	PM-K24
	L type 		PM-K24P
			PM-K24-R
	F type 		PM-L24
			PM-L24P
	R type 		PM-L24-R
U type 	PM-F24		
	PM-F24P		
	PM-F24-R		
	PM-R24		
			PM-R24P
			PM-R24-R
			PM-U24
			PM-U24P
			PM-U24-R

Note: The suffix "-R" indicates a flexible cable type.

PM Order Guide

Type	Appearance (mm in)	Sensing range	Model no. (Note)	
Small	With cable	5 mm (fixed)	K type	PM-K44
				PM-K44P
			T type	PM-T44
				PM-T44P
			L type	PM-L44
				PM-L44P
	Y type		PM-Y44	
			PM-Y44P	
	F type		PM-F44	
			PM-F44P	
	R type		PM-R44	
			PM-R44P	
With connector	K type		PM-K54	
			PM-K54P	
		T type	PM-T54	
			PM-T54P	
		L type	PM-L54	
			PM-L54P	
	Y type	PM-Y54		
		PM-Y54P		
	F type	PM-F54		
		PM-F54P		
	R type	PM-R54		
		PM-R54P		

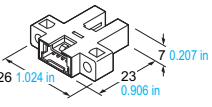
Order Guide

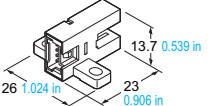
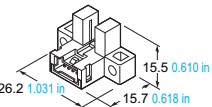
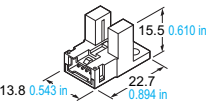
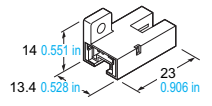
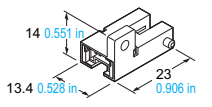
Type	Appearance (mm in)	Sensing range	Model no. (Note)
Small and built-in connector type	 26 1.024 in, 7 0.207 in, 23 0.906 in	 5 mm (fixed)	PM-K64
			PM-K64P
	 26 1.024 in, 13.7 0.539 in, 23 0.906 in		PM-T64
			PM-T64P
	 26.2 1.031 in, 15.7 0.618 in, 15.5 0.610 in		PM-L64
			PM-L64P
	 13.8 0.543 in, 15.5 0.610 in, 22.7 0.894 in		PM-Y64
			PM-Y64P
	 14 0.551 in, 13.4 0.528 in, 23 0.906 in		PM-F64
			PM-F64P
	 14 0.551 in, 13.4 0.528 in, 23 0.906 in		PM-R64
			PM-R64P

Options

Designation	Model no.	Description
Connector	CN-14	Connector for soldering
Hook-up connector	CN-14H	This connector can be hooked-up on 0.08 to 0.2 mm ² cable simply in one grip. Wire diameter: ϕ 0.7 to ϕ 1.2 mm ϕ 0.028 to ϕ 0.047 in
	CN-14H-2	Suitable for UL standard cable. This connector can be hooked-up on 0.18 to 0.22 mm ² cable simply in one grip. Wire diameter: ϕ 1.2 to ϕ 1.52 mm ϕ 0.047 to ϕ 0.060 in
Connector attached cable	CN-14H-C1	Length: 1 m 3.281 ft Net weight: 20 g approx.
	CN-14H-C3	Length: 3 m 9.843 ft Net weight: 65 g approx.
Hook-up pliers	CN-HP	For the connector type, with 0.18 mm ² 4-core cabtyre cable Cable diameter: ϕ 3.8 mm ϕ 0.150 in These are exclusive pliers for hook-up connectors CN-14H and CN-14H-2

Connector

- CN-14

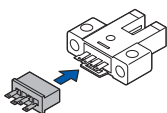

Hook-up connector

- CN-14H
- CN-14H-2

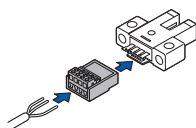

Connector attached cable

- CN-14H-C1
- CN-14H-C3

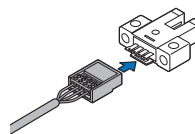

Hook-up pliers

- CN-HP

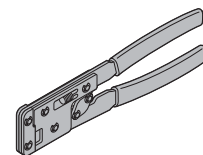

PM2

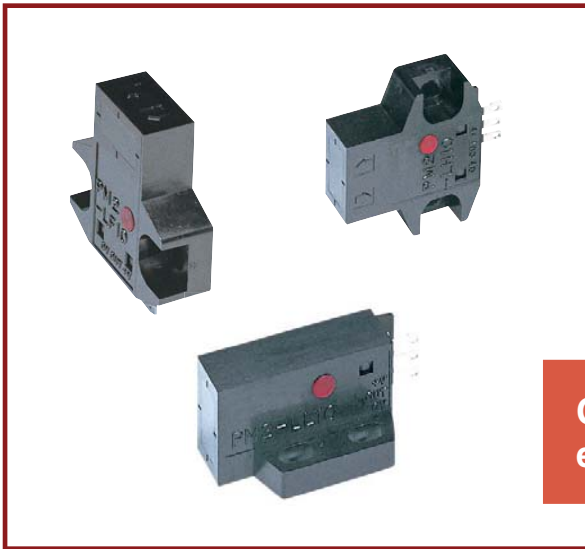

PM2

Convergent reflection sensing ensures stable detection

Features

Stable detection by convergent reflective mode

Stable detection characteristics are obtained since it is a convergent reflective type and senses a limited area.

Not affected by background

Even a specular background does not affect the sensing performance if the sensor is located 30mm away from it (when directly opposite).

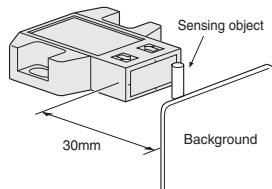

Dark object detectable

Since the sensor is very sensitive, it can detect even a dark object of low reflectivity.

Minute object detectable

A $\varnothing 0.05\text{mm}$ copper wire can be detected at a distance of 5mm.

Sensing printed circuit boards

Minute object detectable.

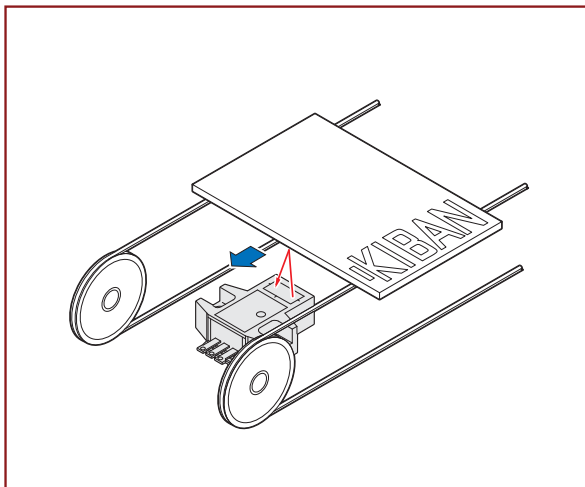

Sensing the starting point and overrun of a moving body

Starting point and overrun is sensed using the dog on the base.

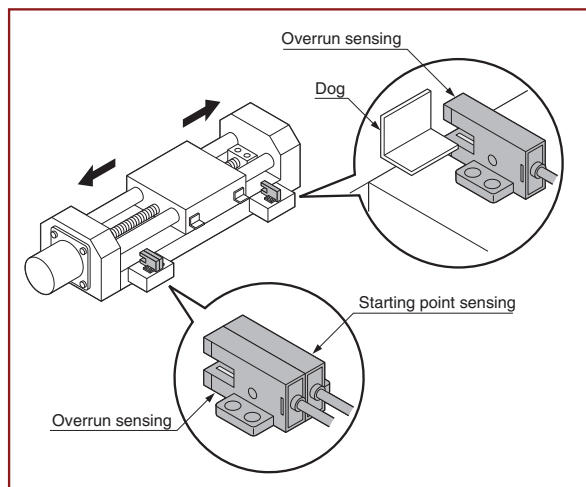

Typical Applications

Detecting capacitors in tray

The convergent reflective type sensor reliably detects capacitors in a tray without being affected by their color, characters, marks, or glossiness.

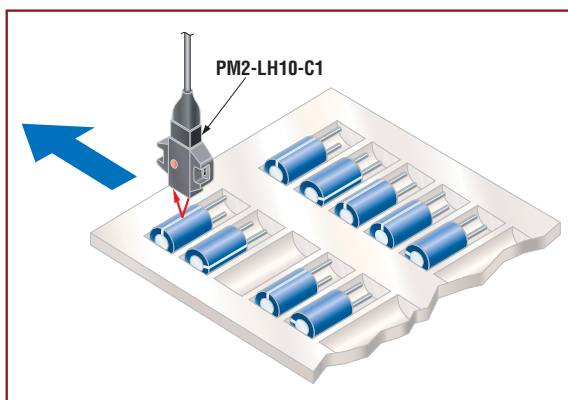

Options

Designation	Model no.	Description
Connector	CN-14	Connector for soldering
Connector attached cable	CN-14H-C1	0.2mm ² 3-core cabtyre cable, 1m long
	CN-14H-C3	0.2mm ² 3-core cabtyre cable, 3m long

Connector

- CN-14

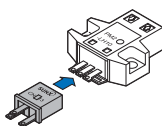

Connector attached cable

- CN-14H-C1
- CN-14H-C3

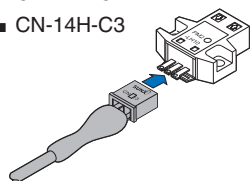

Order Guide

Type	Appearance	Sensing range	Model no. (Note)
Connector type	Top sensing	2.5 to 8mm	PM2-LH10
			PM2-LH10B
	Front sensing		PM2-LF10
	PM2-LF10B		
L type (Top sensing)	PM2-LL10		
	PM2-LL10B		
Cable type	Top sensing		PM2-LH10-C1
			PM2-LH10B-C1
	Front sensing		PM2-LF10-C1
	PM2-LF10B-C1		
L type (Top sensing)	PM2-LL10-C1		
	PM2-LL10B-C1		

Technical Specifications

Type	Connector			Cable			
	Top sensing	Front sensing	L type (Top sensing)	Top sensing	Front sensing	L type (Top sensing)	
Model no.	Light-ON	PM2-LH10	PM2-LF10	PM2-LL10	PM2-LH10-C1	PM2-LF10-C1	PM2-LL10-C1
	Dark-ON	PM2-LH10B	PM2-LF10B	PM2-LL10B	PM2-LH10B-C1	PM2-LF10B-C1	PM2-LL10B-C1
Sensing range	2.5 to 8mm (conv. point: 5mm) with white non-glossy paper (15×15mm)						
Min. sensing object	∅0.05mm copper wire (setting distance: 5mm)						
Repeatability (perpendicular to sensing axis)	0.08mm						
Supply voltage	5 to 24VDC±10%						
Output	NPN open-collector transistor						
Response time	0.8ms or less						
Emitting element	Infrared LED (modulated)						

NA1-11



NA1-11

Cross-beam scanning system to detect slim objects

Features

Letter or business card detectable

Thin objects can be detected by using the cross-beam scanning system.

Emitting and receiving element pitch: 10mm

A minimum sensing object size of $\varnothing 13.5\text{mm}$ is realized by using an emitting and receiving element pitch of 10mm.

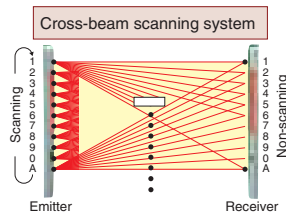

Wide area

Though very slim a wide sensing area of 1m length and 100mm width is realized. It is most suitable for object detection on a wide assembly line, or for detecting the dropping of, or incursion by, small objects whose travel path is uncertain.

Clearly visible large indicator

A clearly visible large indicator having a 55mm width is incorporated on both the emitter and the receiver.

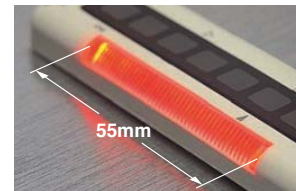

Typical Applications

Detecting postcards

NA1-11 can detect thin postcards due to its crossbeam scanning system.

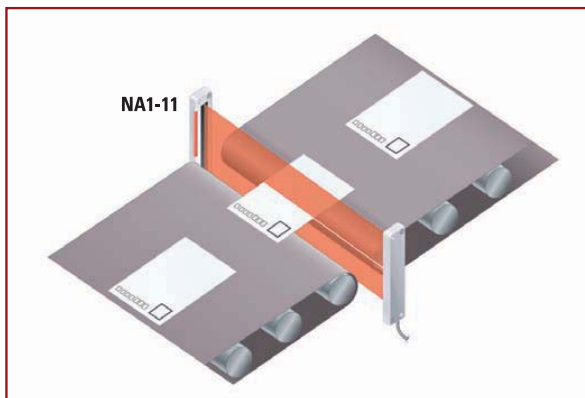

Technical Specifications

Model no.	NA1-11	NA1-11-PN
Sensing height	100mm	
Sensing range	0.17 to 1m (Note 1)	
Element pitch	10mm	
Number of emitting/ receiving elements	11 each on the emitter and the receiver, respectively	
Sensing object	∅13.5mm or more opaque object (Note 2)	
Supply voltage	12 to 24VDC ±10%	
Output	NPN open-collector transistor	PNP open-collector transistor
Ambient temperature	-10 to +55°C	
Dimensions	W30×H140×D10mm	

Notes: 1) The sensing range is the possible setting distance between the emitter and the receiver.
The sensor can detect an object less than 0.17m away.

2) Although this product can detect slim objects by using the cross-beam scanning system, the size of the slim object which can be stably detected differs with the setting distance. When this sensor is used to detect slim objects, make sure to confirm stable detection using the actual objects.

NA1-PK5/NA1-PK3



NA1-PK5/ NA1-PK3

Ultra-slim body pick-to-light sensor

Features

10 mm thick: half the thickness of conventional models

Space saving now possible; ultra-thin design does not obstruct picking operations.



Cable can be freely arranged in any position

Two unit installations are possible

Sensor units can now be set to different light emission frequencies in order to prevent mutual interference.

Two units can now be operated in a side-by-side configuration without interference for problem-free detection over wider areas.

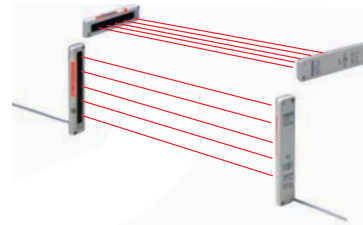

Lighting pattern selectable

The job indicator operation can be selected as either continuous lighting or blinking.

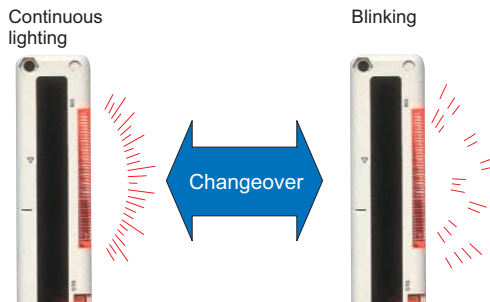

Selectable detection operation

Sensor units can be set to detect the interruption of 1 beam channel or 2 or more beam channels.

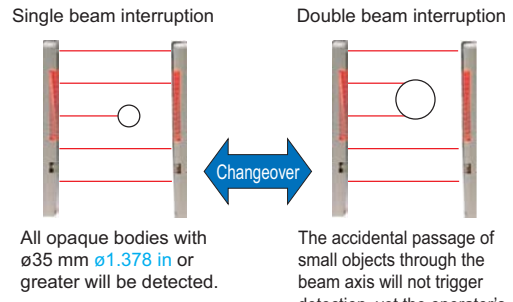

All opaque bodies with $\varnothing 35 \text{ mm } \varnothing 1.378 \text{ in}$ or greater will be detected.

The accidental passage of small objects through the beam axis will not trigger detection, yet the operator's hands will always be accurately detected. This function is also useful when small objects regularly interrupt the beam axis.

Typical Applications

Cell production line



Assembly line

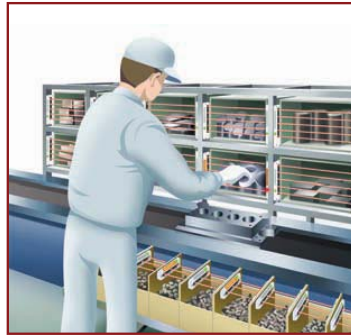

Technical Specifications

	NPN output		PNP output	
	NA1-PK5	NA1-PK3	NA1-PK5-PN	NA1-PK3-PN
Sensor type	Picking sensor			
Sensing height	100mm	49.2mm	100mm	49.2mm
Sensing range	0.1 to 1.2m	0.03 to 0.3m	0.1 to 1.2m	0.03 to 0.3m
Beam pitch	25mm	24.6mm	25mm	24.6mm
Number of beam channels	5 beam channels	3 beam channels	5 beam channels	3 beam channels
Sensing object	∅35mm or more, opaque object	∅29mm or more, opaque object	∅35mm or more, opaque object	∅29mm or more, opaque object
Supply voltage	12 to 24V DC ±10%			
Output	NPN open-collector transistor, max.100mA		PNP open-collector transistor, max.100mA	
Dimensions (W×H×D)	30x140x10	24x70x8	30x140x10	24x70x8

EQ-500



EQ-500

Long range sensing capability up to 2.5m

Features

1m sensing range type EQ-502(T)/512(T)

Impervious to variations in color or angle

Due to its advanced optical system, the sensor is not affected by variations in the object's angle or gloss as compared to conventional sensors. Moreover, sensing can be performed at a somewhat constant distance even if the sensing object is black or white.

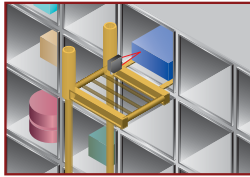

Note: Sensing range difference is 5% or less between white non-glossy paper and non-glossy paper (gray) with lightness 5 at a setting distance of 2m. [EQ-5M1(T)]

Not affected by background objects

Due to the 2-segment photodiode adjustable range system, the sensor does not detect objects outside the preset sensing field; it will not malfunction even if someone walks behind the sensing object, or machines or conveyors are in the background.

An easy-to-set adjuster with indicator

Equipped with a 2-turn adjuster with indicator, making it easy to set for short or long distances.

It can function with 24 to 240VAC and 12 to 240VDC. Therefore, almost any power supply anywhere in the world will work.



Multi-voltage type EQ-501(T)/502(T)

Equipped with BGS/FGS function

We have added a DC-voltage type with NPN and PNP transistor outputs, all in one sensor. Its BGS/FGS function controls any background effects for more stable sensing.

DC-voltage type EQ-511(T)/512(T)

Convenient timer function models

Types with an ON-delay/OFF-delay timer available. (EQ-5□T) OFF-delay, e.g. useful when the response of the connected device is slow, ON-delay, e.g. useful to detect objects that take a long time to move.

- Operation: ON-delay
OFF-delay
- Timer period: 0.1 to 5sec. (individual setting possible)



Little affected by contamination on lens

Even if the lens surface gets somewhat dirty from dust particles, there is very little change in the operation field, rendering stable and consistent detection even for objects appearing close to the front surface of the unit.

Convenient terminal block type

Cabling is enabled by way of a terminal block that eliminates waste.

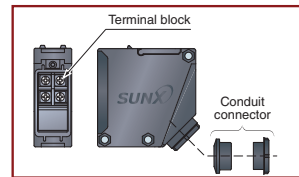

Technical Specifications

EQ-500

Type	Multi-voltage				DC-voltage			
	With timer		With timer		With timer		With timer	
Model. no.	EQ-501	EQ-501T	EQ-502	EQ-502T	EQ-511	EQ-511T	EQ-512	EQ-512T
Adjustable range (Note)	0.2 to 2.5m		0.2 to 1.0m		0.2 to 2.5m		0.2 to 1.0m	
Sensing range (at maximum setting distance)	0.1 to 2.5m		0.1 to 1.0m		0.1 to 2.5m		0.1 to 1.0m	
Supply voltage	24 to 240VAC ±10% or 12 to 24VDC ±10%				12 to 24VDC ±10%			
Output	Relay contact 1a				NPN open-collector transistor and PNP open-collector transistor 2 outputs			
Output operation	Switchable either Detection-ON or Detection-OFF							
Response time	20ms or less (for EQ-50MT dependent on the setting timer period)				2ms or less (for EQ-51MT dependent on the setting timer)			
Timer function	-	Incorporated with variable (0.1 to 5sec.) ON-delay / OFF-delay timer	-	Incorporated with variable (0.1 to 5sec.) ON-delay / OFF-delay timer	-	Incorporated with variable (0.1 to 5sec.) ON-delay / OFF-delay timer	-	Incorporated with variable (0.1 to 5sec.) ON-delay / OFF-delay timer
Protection	IP67 (IEC)							
Ambient temperature	-20 to +55°C							
Emitting element (modulated)	Infrared LED (modulated)							
Dimensions (W×H×D)	26×68×68mm							

Note: The adjustable range stands for the maximum sensing range which can be set with the distance adjuster.
The sensor can also detect an object 0.1m, or more, away.

EQ-30



EQ-30

Unaffected by color or material,
2m distance adjustable fixed-focus
sensing

Features

Not affected by object color or background

Long sensing range 2m

Compact size

The EQ-30 saves space, since a miniaturized housing of 20×68×40mm (W×H×D) has been designed for the fixed-focus sensing sensor.

Two setting distances are possible: EQ-34W

With **EQ-34W**, two sensing distances, Far (Main) and Near (Sub), can be set. Hence, one sensor can suffice where previously two were required.

Plug-in connector type (excluding EQ-34W)

Plug-in connector type of the **EQ-30** series can be easily disconnected for replacement. Should a problem occur, anyone would be able to replace the sensor in a minute.

Typical Applications

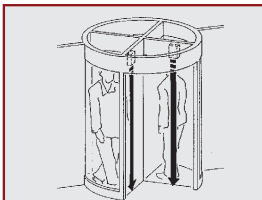

Long distance sensing

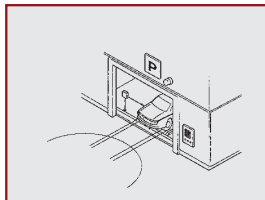

Object detection

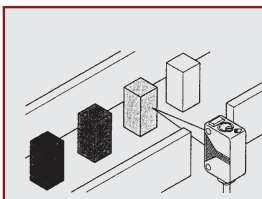

Color-independent presence sensing

Technical Specifications

NPN output	EQ-34 (J)	EQ-34W *
PNP output	EQ-34PN (J)	
Sensor type	Diffuse	Diffuse/double output
Rated sensing distance	200cm	
Sensing range	10–200cm	Near: 10–200cm Far: 20–200cm
Standard detectable object	White drawing paper 20×20cm	
Detectable target	Transparent and opaque material	
Hysteresis	≤10% of measurement	
Response time	Max. 2ms	
Outputs	Transistor max. 100mA	
Emitting diode	Infrared LED 880nm	
Rated current consumption without load	NPN type: 50mA PNP type: 55mA	2 x NPN type: 90mA
Housing material	Plastic	
Protection	IP67	
Physical size (H×W×D)	68×20×40mm	
Connection method	2m cable or M12 connector (J)	
Operating voltage	10 to 30V DC (±10%)	
Usable ambient temperature	−20°C to +55°C	
Weight	Approx. 150g	

* (Two outputs)



MQ-W

Very accurate detection by triple beam triangulation sensing method in a compact package

Features

Accurate detection

Regardless of color, material, or shape of objects area reflective type sensor can detect white or black objects at the same distance. In case of diffuse reflective types, which cannot always detect objects of various color with the same sensitivity setting, the MQ-W area reflective type sensor is a worthy substitute.

No-miss operation regardless of backgrounds

Area reflective type sensors do not detect objects beyond the set range.

Resistant to lens surface soiling

Area reflective type sensors detect the distance by the angle, not the intensity of received light. Even if the lens surface is soiled by dust or powdery material, there is little variation in sensing range.

Typical Applications

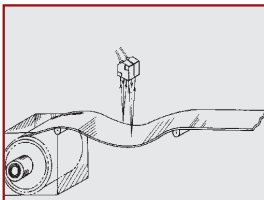

Distance detection

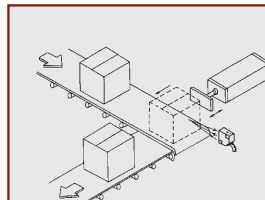

Position detection

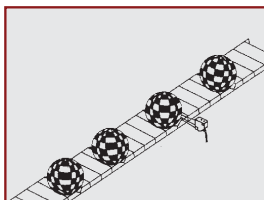

Color-independent detection

Technical Specifications

NPN output	MQ-W3A(R)	MQ-W20A(R)	MQ-W70A
PNP output	MQ-W3C(R)	MQ-W20C(R)	MQ-W70C
Sensor type	Diffuse		
Rated sensing distance	3cm	20cm	70cm
Sensing range	2-4cm	4-20cm	20-70cm
Standard detectable object	White drawing paper		
	1×1cm	2×2cm	7.5×7.5cm
Detectable target	Transparent and opaque material		
Hysteresis	≤10% of measurement range	≤20% of measurement range	
Detection frequency	250Hz		
Response time	2ms		
Output relay	-		
Output transistor	Max. 100mA, NPN/PNP		
Wavelength of emitting diode	Type R: 660nm 910nm	880nm	
Rated current consumption	Max. 30mA		
Housing material	Zinc die cast		
Protection	IP67		
Physical size (H×W×L)	32×12.6×32mm		52×18.6×52mm
Connection method	2m cable		
Operating voltage	12 to 24VDC (-20% / +25%)		
Usable ambient temperature	-25°C to +55°C		
Weight	Approx. 126g		Approx. 235g

ST4



ST4

Excellent basic functions at a reasonable price

Features

Series connection of 6 sets of sensor heads to 1 controller

SUNX new concept of connecting 6 sets of sensor heads to 1 controller in series offers you maximum flexibility to solve your safety application.

Beam axis alignment and operation confirmation

The beam interruption indicator is incorporated in both the emitter and receiver. This indicator can be used not only to confirm operation but also to align the beam axis.

Compact sensor head saves space

The size of the type 4 long sensing range type is similar to general purpose photoelectric sensors.

IP67 degree of protection

The sensor heads can be used safely even on lines where water splashes.

Interference prevention

The emission amount adjuster can be used to prevent interference to the surrounding sensors.

Supports both PNP and NPN polarities

A single unit supports both PNP and NPN polarities, easing stock management.

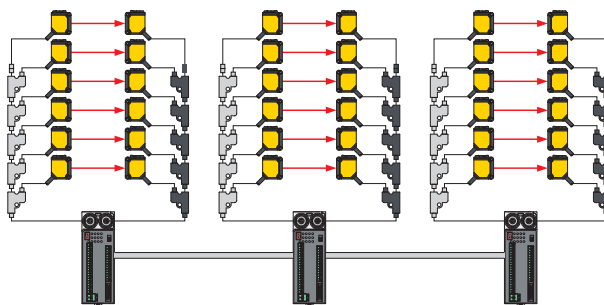
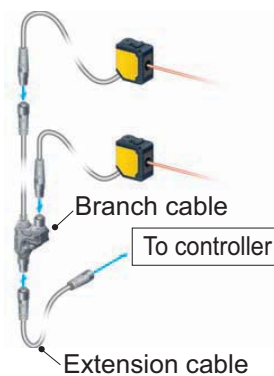

Typical Applications

Protection for long sensing ranges

Guard areas up to 15m in length, for example where protective fences are difficult to install.

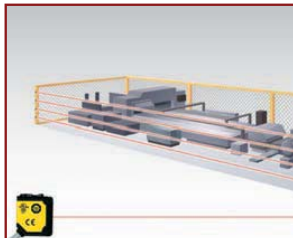

Protection for small openings

For small openings where light curtains do not fit, ST4 sensor heads ensure safety.



Protection against non-authorized entry

Sensor heads can be mounted flexibly and muting control implemented easily.



Technical Specifications

Sensor Heads	Cable length 0.2m		Cable length 1m	
		With emission amount adjuster		With emission amount adjuster
Model no.	ST4-A1-J02	ST4-A1-J02V	ST4-A1-J1	ST4-A1-J1V
Operating range	0.1 to 15m			
Sensing object	ø9 mm or more opaque object			
Supply voltage	Supplied from controller			
Current consumption	Emitter: 11mA or less, Receiver: 9mA or less			
Protection	IP67			
Weight	45g		100g	
Usable ambient temperature	-10 to +55 °C (No dew condensation or icing allowed), Storage: -25 to +70°C			
Emitting element	Infrared LED (Peak emission wavelength: 870nm)			
Material	Enclosure: PBT (Polybutylene terephthalate), Lens: Acrylic, Indicator cover: Acrylic			
Cable	Shielded cable with connector, 0.2m long		Shielded cable with connector, 1m long	
Safety category	EN 13849-1 (Category 4)			

Sensor type	Controller	High-functional controller
	ST4-C11	ST4-C12EX
Supply voltage	24VDC +10/ -15% Ripple P-P 10% or less	
Current consumption	100mA or less (excluding sensor heads)	120mA or less (excluding sensor heads)
Output transistors	OSSD1 and OSSD2 (PNP or NPN, switchable), max. 200mA	
Response time	ON -> OFF: 25ms or less OFF -> ON: 90ms or less (auto reset) / 140ms or less (manual reset)	
Protection	Enclosure: IP40 (IEC), Terminal: IP20 (IEC)	
Ambient temperature	-10 to +55 °C (No dew condensation or icing allowed), Storage: -25 to +70°C	
Material	Enclosure: ABS	
Weight	180g	240g

SF2B

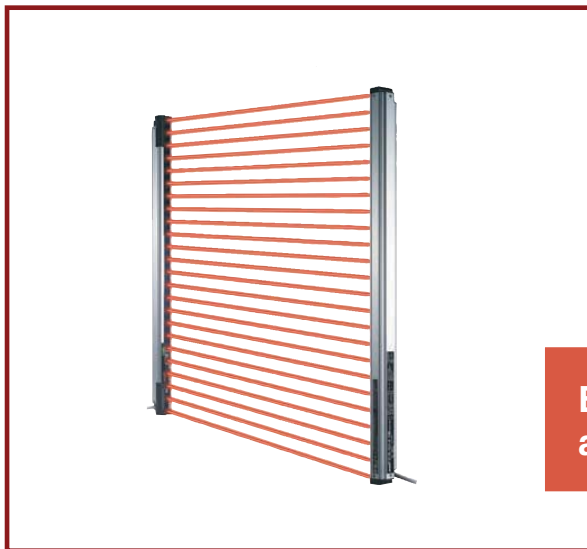

SF2B

Type 2 · PLd · SIL2

Excellent basic functions
at a reasonable price

Features

Unit length = Protective height, 'ZERO' dead zone

Non-wasteful installation is possible, with no dead corners in the sensing width.

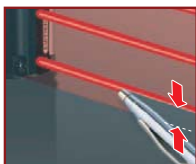

Seamless structure using an inner enclosure

The internal unit fits into an inner enclosure completely eliminating seams (joints) inside the product.

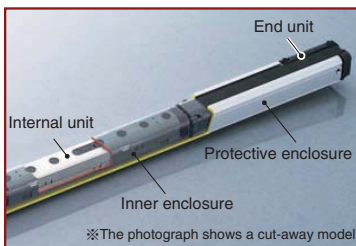

Also suppresses mutual interference and effects of extraneous light

The tried and proven ELCA function suppresses operating errors resulting from mutual interference and the effects of extraneous light, and prevents drops in line efficiency rates from occurring.



Supports resolution of electrical problems when starting up lines

Equipped with a digital error indicator so that error details can be understood at a glance!

Technical Specifications

Type	Hand protection type		Arm / Foot protection	
	NPN output	PNP output	NPN output	PNP output
Model no.	SF2B-H□-N	SF2B-H□-P	SF2B-A□-N	SF2B-A□-P
Safety category	Type 2, PLd, SIL2			
Beam pitch	20mm		40mm	
Operating range	0.2 to 13m			
Protective height	168 to 1912mm			
Min. sensing object	∅27mm opaque object		∅47mm opaque object	
Supply voltage	24VDC ±10%			
Control output	NPN output type: NPN open collector transistor PNP output type: PNP open collector transistor			
Response time	OFF response: 15ms or less, ON response: 40 to 60ms			
Ambient temperature	-10 to +55°C			
Dimensions	W28×H protective height×D24mm			

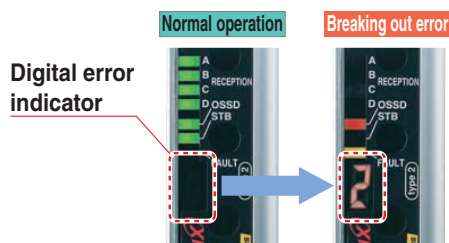

SF4B<V2>

Type 4 · PLe · SIL3

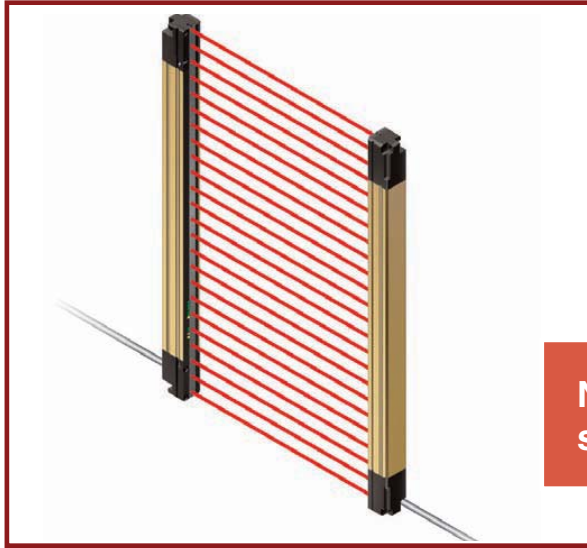

New concepts combining greater safety and higher productivity!

Features

'ZERO' dead zone

The length of the main unit equals the protective height so that installation is possible in places where space is limited. No dead zone occurs at the joints between light curtains when light curtains are connected in series.

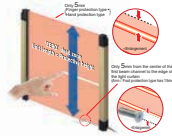

3 types available for different workplace conditions

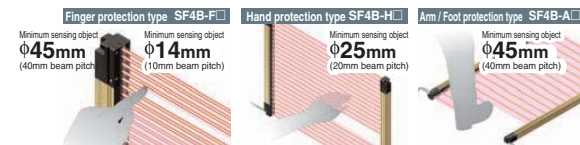

Same response time of 14ms and constant safety distance

A fast response time of 14ms has been achieved regardless of the number of beam channels, the beam axis pitches and the number of units connected in series. This reduces calculation work required for the safety distances.

A muting control function is provided to increase without compromising safety productivity

The light curtain is equipped with a muting control function that causes the line to stop only when a human body passes through the light curtain, and does not stop the line when a workpiece passes through.

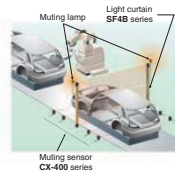

The safety relay unit capability is built into the light curtain so component costs can be reduced

The light curtain has a built-in external device monitoring function (such as for fused relay monitoring) and an interlock function. The safety circuit is constructed so that a separate safety relay unit is not needed, and the control board is also more compact, both of which contribute to lower costs.

Reduces malfunction due to mutual interference and extraneous light

The advanced ELCA function used in the SF4-A that has been widely acclaimed in the marketplace has also been adopted into the SF4B in order to suppress mutual interference. In addition, the unique double scanning method and retry processing developed by SUNX greatly reduce malfunctions due to extraneous light.

Equipped with a digital error indicator

If an error occurs, details of the error appear on the digital display so that maintenance can be carried out more quickly.



Universal design that can be used anywhere in the world

The SF4B series combines PNP transistor output and NPN transistor output in a single model. Overseas equipment that uses PNP, replacement with NPN sensors, factories that are positively grounded, and transfer of equipment overseas are all situations where the control circuits for a single model are suitable for use worldwide.

SF4B<V2> Typical Applications

Guarding space around welding robot

The spatter protection hood type perfect for welding devices is also available.

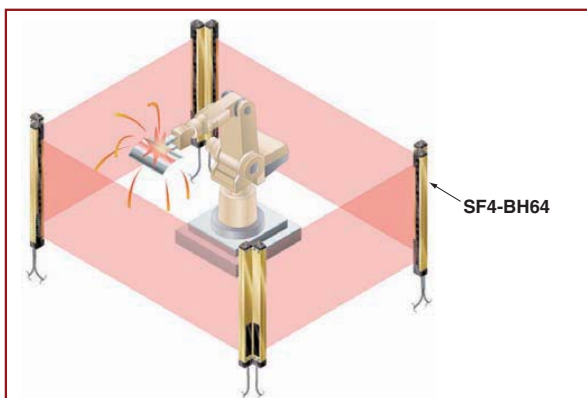

Technical Specifications

Type	Finger protection type	Hand protection type	Arm / Foot protection type
Model no.	SF4B-F□□<V2>	SF4B-H□□<V2>	SF4B-A□□<V2>
Safety category	Type 4, PLe, SIL3		
Beam pitch	10mm	20mm	40mm
Operating range	0.3 to 7m	0.3 to 9m (72 beam channels or more: 0.3 to 7m)	0.3 to 9m (36 beam channels or more: 0.3 to 7m)
Protective height	230 to 1270mm	230 to 1910mm	230 to 1910mm
Min. sensing object	14mm or more in opaque object	25mm or more in opaque object	45mm or more in opaque object
Supply voltage	24VDC ± 10%		
Control output	PNP open collector transistor / NPN open collector transistor (selectable using wiring)		
Response time	OFF response: 14ms or less, ON response: 80 to 90ms		
Dimensions	W28 × protective height × D30mm		

□□ Number of beams



SF4C

Type 4 · PLe · SIL3

Ultra-slim light curtain machines safeguards without sacrificing productivity

Features

Large built-in multi-purpose indicators

Large LED bars on each side of the light curtain provide a wide visibility indicator that can be customized for various applications by means of independent external inputs. The indicator can be used as an operation indicator, job indicator, etc.

Slim size for efficient applications

Available work space is expanded from the previous model, and productivity is improved.

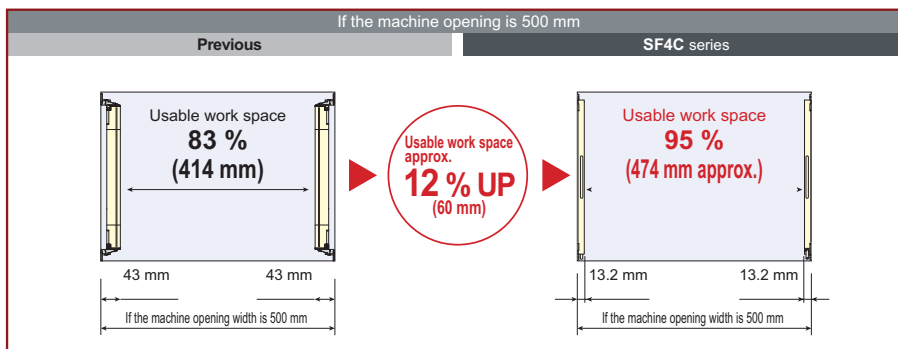

Can be used in a variety of applications for simplified equipment (Large multi-purpose indicator)

The bright LED indicators located in the center of both sides of each light curtain can be illuminated green or red by using external inputs. There is no need to set up a separate indicator..

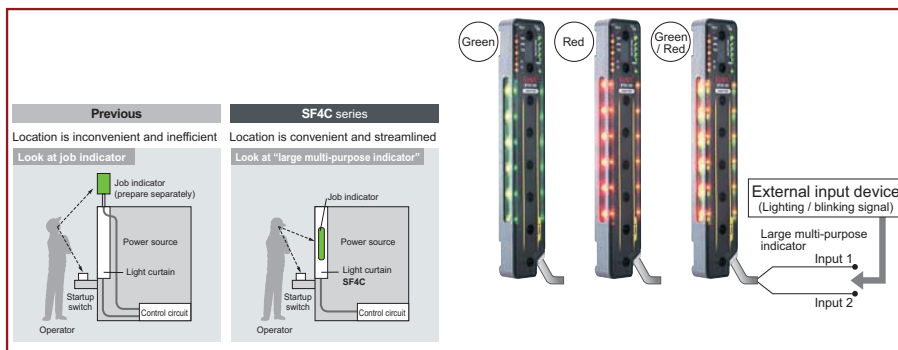

SF4C Wire-saving when connecting to safety devices [safety input functions]

Contact outputs such as emergency stop switches or safety door switches can be connected to the light curtain. Also, by using the handy-controller **SFC-HC**, up to three sets of light curtains can be cascade connected for a consolidated safety output.

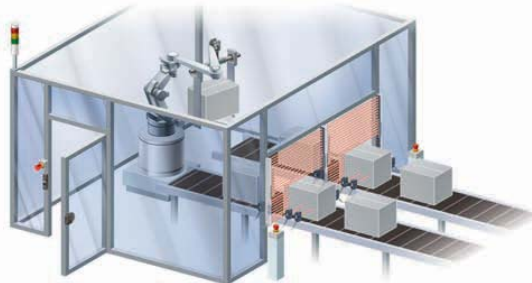

Direct connection of safety devices

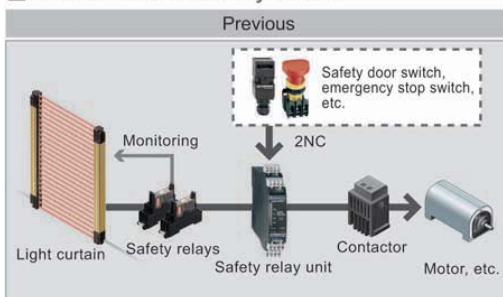

A safety relay unit is needed for connecting safety devices other than light curtain.

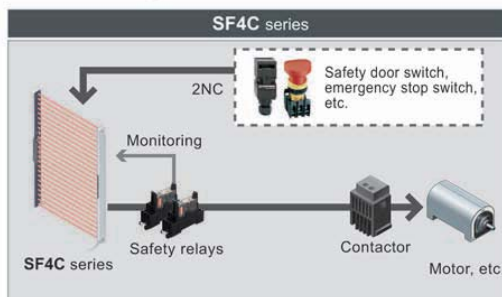

Direct connection of various safety devices is possible for a simplified safety circuit.

By using the handy-controller SFC-HC (available soon) up to three sets of light curtains can be cascade connected for a consolidated safety output. **HC**

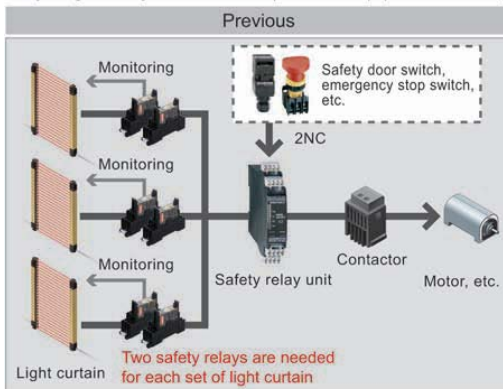

Three sets of light curtains require three sets of safety relays.

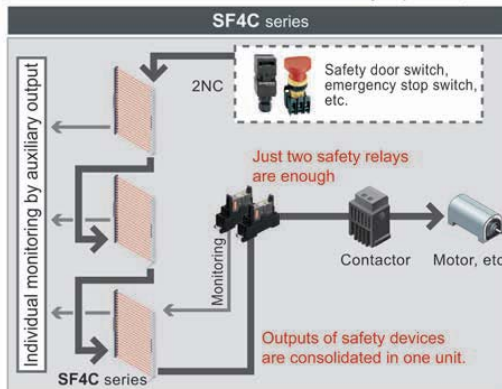

Individual monitoring on light curtains is possible while the outputs of three sets of light curtains and other safety devices are consolidated in one unit.

IP67 protection structure

An IP67 (IEC / JIS) rating is achieved with an ultra-slim size for protection from environmental factors.

Mutual interference is reduced without needing interference prevention lines

The light curtain is equipped with the ELCA (Extraneous Light Check & Avoid) function, which has been proven to be strong against mutual interference. Because it automatically shifts the scan timing of the light curtain in order to avoid interference, it is not necessary to wire interference prevention lines between machinery.

Safety, productivity, and cost reduction [muting control function]

The light curtain has a built-in muting control function that causes the line to stop only when a person passes through the light curtain, and does not stop the line when an object passes through. The muting sensors and muting lamps can be connected directly to the light curtain. Furthermore, the large multi-purpose indicators can be used as muting lamps, which contribute to less wiring troubles, improvement of safety and productivity, and cost reduction.

A fast response time of 7ms* for all models

A fast response time of 7ms* is unified for all models regardless of the number of beam channels. This reduces the safety distance as well as the calculation work required for the safety distance among models with different beam channels.

* When connecting safety sensors (light curtains, etc) to the safety input, the response time will be the total time of connected units.

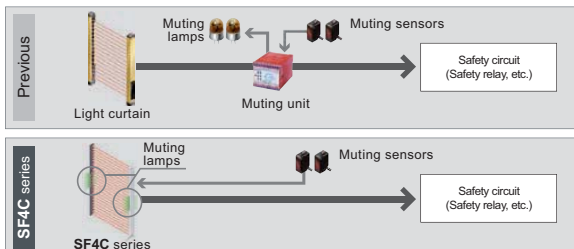

* If a failure diagnosis of muting lamp is needed as by the result of risk assessment, use the handy-controller **SFC-HC** to change the setting, and connect the muting lamp output wire (red) of this light curtain to an incandescent lamp separately.

Typical Applications

Use a muting lamp

There is no need to buy and install a separate muting lamp.

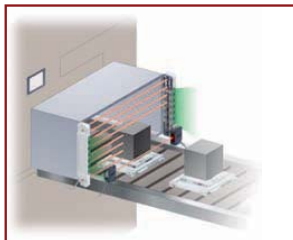

Selective muting area

Separate muting control function for each beam channel.

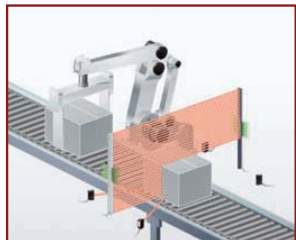

Industry first!

Wire-saving when connecting to safety devices (safety input function)

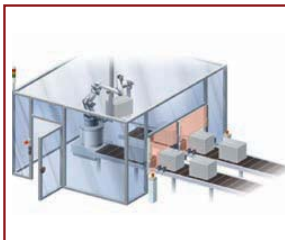

SF4C Technical Specifications

Type Beam pitch	SF4C pigtailed type	SF4C cable type
	Hand protection type 20mm	
Safety category	Type 4, PLc, SIL3	
Operating range	0.1 to 3m	
Protective height	160mm to 640mm	
Min. sensing object	Ø25mm or more in opaque object	
Supply voltage	24V DC (+10/-15%)	
Control output	OSSD1 and OSSD2 (2xPNP or 2xNPN, switchable), max. 200mA	
Response time	OFF response: 7ms or less / ON response: 90ms or less	
Dimensions	W13,2 x protective height x 30mm	



SD3-A1

Type 3 · PLd · SIL2

Monitor dangerous areas for unauthorized entry using flexible detection zones!

Features

Freely configurable zones

Two zones can be monitored with the SD3-A1: the warning zone within a radius of 15m, and the protection zone within a radius of 4m. You can configure the contours of these zones to perfectly accommodate any application. You can configure up to eight zone patterns and switch between them at any given time, even during operation. This flexible zone configuration can be done by PC.

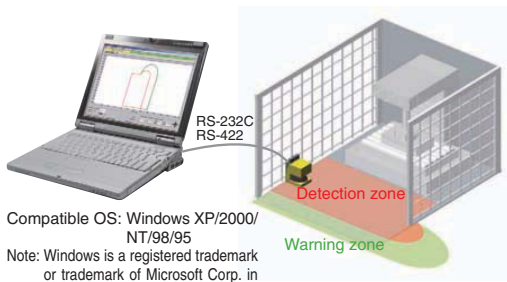

Compatible OS: Windows XP/2000/
NT/98/95
Note: Windows is a registered trademark
or trademark of Microsoft Corp. in
the U.S. and/or other countries.

Adjustment of response times enables interference prevention

The response time can be adjusted from 80 to 640ms. Mutual interference can be prevented by adjusting the response time when setting up multiple safety laser scanners in close vicinity.



Monitors beam misalignment after installation of safety laser scanner

By activating the reference boundary function which enables constant detection of stationary objects, the safety laser scanner memorizes the position of stationary objects, and monitors for beam misalignment after installation.

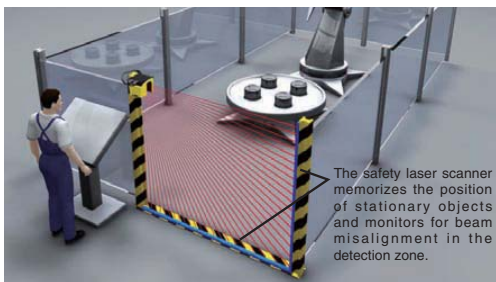

The safety laser scanner memorizes the position of stationary objects and monitors for beam misalignment in the detection zone.

Memorized configurations make post-maintenance recovery easy (optional)

Configurations can be saved in the optional configuration plug's built-in memory and reloaded after maintenance or exchanging safety laser scanners.

SD3-A1 Typical Applications

Detecting entry into dangerous areas at processing machines

Warning and machine halt zones are implemented to detect workers in dangerous areas.



Confirming safety around automatic guided vehicles

The scanner is used to slow down the vehicle upon detection in the warning zone and stop the vehicle upon entering the protection zone.

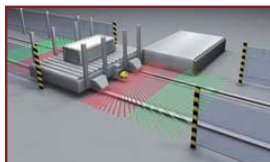

Detecting presence in a defined field

Install two safety laser scanners to build a protection zone surrounding the object in question. Deactivating the zone is also possible.



Guarding the sides of automatic guided vehicles (AGV)

Prevent injuries from a moving AGV. Monitor fallen cargo to avoid collisions.



Detecting entry into dangerous areas of circular cycle tables

One safety laser scanner can safeguard the front opening where in the past two sets of light curtains were needed.



Detecting entry into areas with robots

The scanner detects a human body whenever it enters the field.



Technical Specifications

Type	Safety laser scanner					
Model no.	SD3-A1					
Safety category	Type 3, PLd, SIL2					
Detection zone	Min. sensing object setting	ø150mm	ø70mm	ø50mm	ø40mm	ø30mm
	Sensing range (radius)	0 to 4.0m	0 to 4.0m	0 to 2.8m	0 to 2.2m	0 to 1.6m
Warning zone	Min. sensing object setting	ø150mm (fixed)				
	Sensing range (radius)	0 to 15m				
Scanning angle	190° / 180° (by setting)					
Measurement zone	Max. measurement range (radius) 50m (fixed)					
Number of zone settings	Max. 7 + 1 (without detection zone)					
Min. zone setting range	200mm					
Supply voltage	24V DC+20 -30%					
Current consumption	300mA approx. (excluding external connection load)					
Control outputs (OSSD 1, OSSD 2)	PNP open-collector transistor 2 outputs Rated operating voltage: supply voltage (UB) -3.2V Max. source current: 250mA Residual voltage: 3.2V or less					
Laser protection class	Class 1 (IEC 60825)					
Degree of protection	IP65					
Ambient temperature	0 to +50°C, Storage: -20 to +60°C					
Material	Main body: Die-cast aluminium, Scanner window: Thermoplastic resin					
Accessories	SD3-PS (exclusive 15-pin connector): 1 pc., SD3-RS232 (exclusive 9-pin connector): 1 pc., Mounting screws (M5 (length 20 mm) hexagon-socket-head bolt: 2 pcs., M5 (length 16mm) hexagon-socket-head bolt: 2 pcs., attached to SD3-PS): 1 set, Simplified instruction manual: 1 copy, Installation CD-ROM (includes detailed instruction manual data): 1 CD					
Weight	Net weight: 2.1kg approx., Gross weight: 2.9kg approx.					

SF-C10



Less setup time for safety light curtains

Features

Supports both PNP and NPN polarities

A single unit can be used for PNP / NPN input switching, reducing the number of parts that need to be registered.

Removable terminal blocks reduce maintenance time

Removable terminal blocks are used. This reduces the work required for re-connecting wiring during maintenance.

SF-C11, SF-C14EX(-01)



Metal enclosure with an IP65 protective structure

The strong metal enclosure has a built-in safety relay. It has an IP65 protective structure so that it can be set up individually without needing to be inserted into a control panel.

SF-C12

Slim design

22.5mm thickness for insertion even into narrow spaces inside panels.

SF-C13

Three safety circuit systems packaged into a single unit!

SF-C14EX(-01)

Three safety circuit systems, light curtain output circuit, muting control circuit, and emergency stop circuit, are packaged into a single unit. This allows safety to be maintained for different sections of the equipment.

FM-200

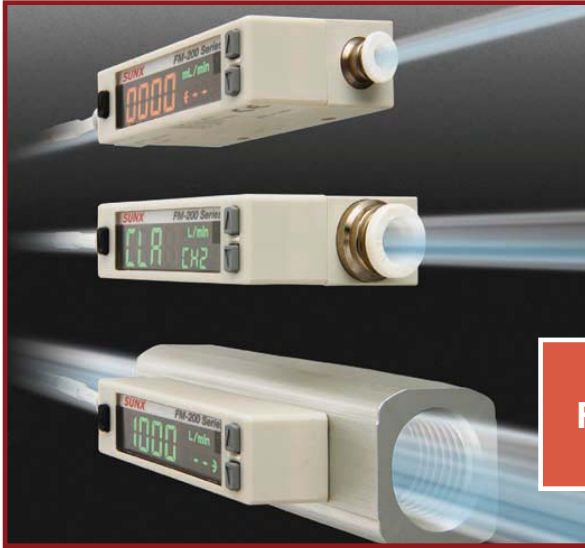

FM-200

Flow sensor with dual display

Features

Easy-to-read, 2-color display with sub display

The setting conditions appear on the sub display, making it much easier to keep track of operations. In addition, the 2-color or digital display lets you check the sensor's operation status at a glance.

High precision of $\pm 3\%$ F.S.

A new rectification mechanism and Micro Electro Mechanical System (MEMS) technology allow the sensor to be mounted on a silicon sensor chip and result in an extremely small heat capacity, high precision of $\pm 3\%$ F.S. and high-speed response. Two temperature sensors, one on either side of the heater, detect heat distribution and make bidirectional detection possible.

One sensor for both intake and exhaust

A single sensor can detect flows bidirectionally, or the forward or reverse direction only, making it suitable for a variety of applications.

Integrated output and pulse output mode incorporated

The FM-200 series can control and manage flows for a wide variety of applications. The integrated output mode will turn the output ON or OFF at the specified integrated value, allowing you to control air blowing volumes, for example. In pulse output mode, a pulse is generated once at each specified integrated value, allowing you to monitor the amount of air consumed, for example.

Economical, ecological

The pulse output can be input to the pulse counter of an Eco-POWER METER so that air consumption and power consumption can be measured simultaneously.

Integrated value reset function

During integrated mode, an external input can reset the integrated value.

Analog voltage output

1 to 5V analog voltage output is incorporated.

Key lock function

Key operation can be disabled to prevent inadvertent operation.

Rattle prevention function

To prevent rattling from rapid changes in flow or from noise, the response time can be set to one of seven steps from 50ms to approximately 1,500ms.

Display rate setting

The display update period can be changed to 250ms, 500ms or 1,000ms in order to eliminate flickering.

ECO mode

In ECO mode, the backlight is turned off after approximately 1 minute if no operation occurs to reduce power consumption.

Typical Applications

Checking suction



Checking seating

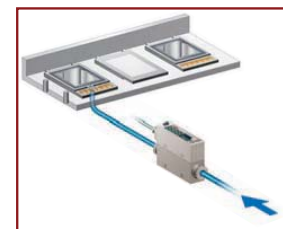

PRESSURE & FLOW SENSORS

Technical Specifications

FM-200

PNP	FM-252-4-P	FM-213-4-P	FM-253-4-P	FM-214-4-P	FM-254-8-P	FM-215-8-P
NPN	FM-252-4	FM-213-4	FM-253-4	FM-214-4	FM-254-8	FM-215-8
Sensor type	Digital flow sensor					
Full scale flow rate	500ml/min	1l/min	5l/min	10l/min	50 l/min	100 l/min
Display range (bar)	±9999999ml		±99999.99l		±999999.9l	
Setting and display resolution	1ml/min		0.01l/min		0.1 l/min	
Rated pressure range	-0.09 to +0.7 MPa					
Pressure resistance (bar)	1Mpa					
Applicable fluid	Clean air, compressed air, nitrogen gas					
Linearity	3%F.S.					
Response time	50ms to 1.5s selectable					
Transistor output	Max. 50mA					
Output modes	Output OFF mode, window comparator mode, hysteresis mode, integrated output mode, integrated pulse output mode					
Analog voltage output	1.0 to 5.0V					
Rated current consumption	Normal mode: 60mA or less, ECO mode: 40mA or less					
Housing material	Resin body type					
Protection	IP40					
Physical size (HxWxL)	37x55x17mm			43x55x17mm		
Connection method	Connector					
Operating voltage	12 to 24VDC ± 10%					
Ambient temperature	0 to + 50°C					
Temperature characteristics	Within ±0.2% F.S./°C (+15°C to +35°C)					
Weight	Net weight: 50g approx.			Net weight: 70g approx.		
Port size	ø4 push-in			ø8 push-in		

PNP	FM-255-AR2-P	FM-255-AG2-P	FM-216-AR2-P	FM-216-AG2-P
NPN	FM-255-AR2	-	FM-216-AR2	-
Sensor type	Digital flow sensor			
Full scale flow rate	500l/min		1.000l/min	
Display range (bar)	±9999999l			
Setting and display resolution	1l/min			
Rated pressure range	-0.09 to +0.7MPa			
Pressure resistance (bar)	1Mpa			
Applicable fluid	Clean air, compressed air, nitrogen gas			
Linearity	3%F.S.			
Response time	50ms to 1.5s selectable			
Transistor output	Max. 50mA			
Output modes	Output OFF mode, window comparator mode, hysteresis mode, integrated output mode, integrated pulse output mode			
Analog voltage output	1.0 to 5.0V			
Rated current consumption	Normal mode: 60mA or less, ECO mode: 40mA or less			
Housing material	Resin/Aluminum body type			
Protection	IP40			
Physical size (HxWxL)	50x80x30mm			
Connection method	Connector			
Operating voltage	12 to 24VDC ± 10%			
Ambient temperature	0 to + 50°C			
Temperature characteristics	Within ±0.2 % F.S./°C (+15°C to +35°C)			
Weight	Net weight: 155g approx.			
Port size	Rc½ female thread	G½ female thread	Rc½ female thread	G½ female thread

DP-100



DP-100

A new global standard, dual display

Features

'Current value' and 'threshold value' can be checked at the same time!

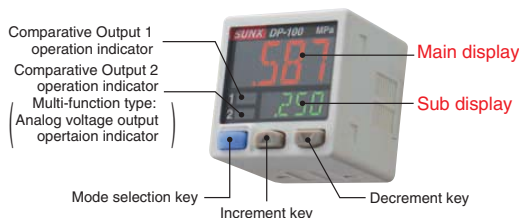

Dual display allows direct setting of threshold value

Equipped with a 30mm square compact-sized dual display. Because the current value and the threshold value can be checked at the same time, the threshold value can be set and checked smoothly without having to switch screen modes.

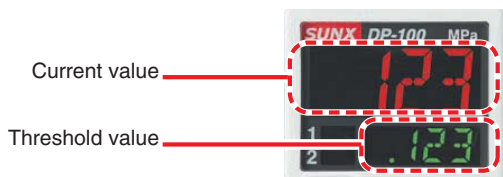

3-color display (Red, Green, Orange)

The main display changes color according to changes in the status of output ON/OFF operation, and it also changes color while setting is in progress. The sensor status can therefore be understood easily, and operating errors can be reduced.

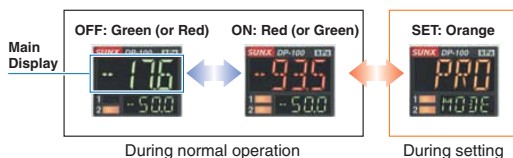

Readable digital display!

12 segments are used and an alphanumeric display has been adopted. This improves visual checking of letters and numbers.



Realizes high performance

Low pressure type

The low pressure type displays measurements in 0.1kPa at a resolution of 1/2000 and has a response time of 2.5ms (variable up to 5000ms), $\pm 0.5\%$ F.S. temperature characteristics and $\pm 0.1\%$ F.S. repeatability, giving it high performance.

Copy function reduces man hours and human error

Sensors can be connected to a master sensor one by one, and a copy of the setting details for the master sensor can be transmitted as data to the other sensors.

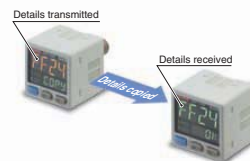

If making the same settings for multiple sensors, this prevents setting errors from occurring with the other sensors and also reduces the number of changes required to instruction manuals when equipment designs are changed.

Equipped with auto-reference/remote zero-adjustment functions

More precise pressure management is possible with a minimum of effort

Multi-function type

If the reference pressure of the device changes, the auto-reference function partially shifts the comparative output judgment level by the amount that the reference pressure shifts, and the remote zero-adjustment function can reset the display value to zero via external input. These functions are ideal for places where the reference pressure fluctuates wildly, or where fine settings are desired.

Typical Applications

Confirming suction of electronic component

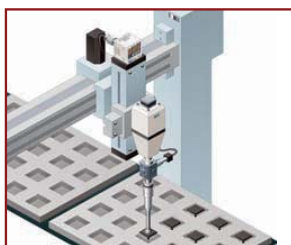

Confirming reference pressure



Air-leak test for PET bottles

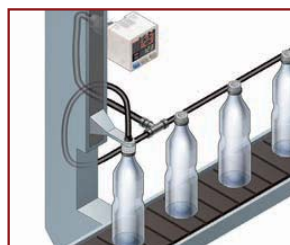

Technical Specifications

Cable types

Type		Compound pressure				
		For low pressure		For high pressure		
Model no.	Asian	DP-101	DP-102	DP-101A	DP-102A	
	European	DP-101-E-P	DP-102-E-P	DP-101A-E-P	DP-102-E-P	
	North American	DP-101-N(-P)	DP-102-N(-P)	DP-101A-N(-P)	DP-102A-N(-P)	
	G 1/8 male thread	Short port type	DP-101-FE-P	DP-102-FE-P	DP-101A-FE-P	DP-102A-FE-P
	M5 female thread		DP-101-M-P	DP-102-M-P	DP-101A-M-P	DP-102A-M-P
Rated pressure range		-100.0 to +100.0kPa	-0.100 to +1.000kPa	-100.0 to +100.0kPa	-0.100 to +100.0kPa	
Applicable fluid		Non-corrosive gas				
Supply voltage		12 to 24VDC ±10%				
Output		NPN output type: NPN open-collector transistor PNP output type: PNP open-collector transistor				
Response time		2.5ms, 5ms, 10ms, 25ms, 50ms, 100ms, 250ms, 500ms, 1,000ms, 5,000ms, selectable by key operation				
Display		4 digits + 4 digits 3-color LCD display				
Pressure port		Asian: M5 female thread + R (PT) 1/8 male thread, European: M5 female thread + G 1/8 male thread, North American: M5 female thread + NPT 1/8 male thread				
Connecting method		Connector				
Accessories		CN-14A-C2 (Connector attached cable 2m): 1pc.				
Dimensions (W×H×D)		30×30×42.5mm				

M8 connector types

Type	Standard		Multi-function	
	For low pressure	For high pressure	For low pressure	For high pressure
Model. no.	DP-111-E-P-J	DP-112-E-P-J	DP-111A-E-P-J	DP-112A-E-P-J
Rated pressure range	-100.0 to +100.0kPa	-0.100 to +1.000 MPa	-100.0 to +100.0 kPa	-0.100 to +1.000 MPa
Applicable fluid	Non-corrosive gas			
Supply voltage	12 to 24VDC ±10%; Ripple P-P 10% or less			
Comparative output	PNP open-collector transistor			
Response time	2.5ms, 5ms, 10ms, 25ms, 50ms, 100ms, 250ms, 500ms, 1,000ms, 5,000ms, selectable by key operation			
Auto-reference function / Remote zero-adjustment function	—		Incorporated	
Analog voltage output	—		Incorporated	
Ambient temperature	-10 to +50°C, Storage: -10 to 60°C			
Pressure port	G1/8 male thread + M5 female thread			
Material	Enclosure: PBT (glass fiber reinforced); LCD display: acrylic; pressure port: stainless steel (SUS303); mounting threaded part: brass (nickel plated); switch part: silicone rubber, M8 connector part: brass • nickel plated (shell)/brass • gold plated (contact)			
Accessories	Unit selection plate: 1			

Note: Where measurement conditions have not been specified precisely, the conditions used were ambient temperature +20°C.

DPH-100 / DPC-100



DPH-100/ DPC-100

Single-axis type digital pressure sensor with optional dual 3-color display

Features

Direct installation using a hexagonal wrench

The sensor head is tightened with a hexagonal wrench, making installation easy, especially in tight spaces.

Dual display + Direct setting

The dual display allows you to check current and threshold values simultaneously.

To facilitate setting operations, three modes have been devised:

- "RUN mode" is for operation settings that are carried out daily
- "MENU SETTING mode" for basic settings
- "PRO mode" for special and detailed setting

Controllers can be connected to a master controller one by one, and the master can transmit settings to the slave controllers. This significantly reduces time required when you need to make multiple, identical settings, or during production change-overs. Moreover, it reduces the possibility for error in such cases.

Automatic sensor head recognition

The controller automatically recognizes sensor heads when they are connected, even if their rated pressure ranges are different.

Typical Applications

Checking suction

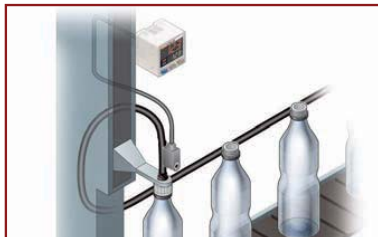

Reference pressure checking



Technical Specifications

DPH-100 / DPC-100

Type	Pressure sensor							
	Compound pressure ±100 kPa type			Positive pressure 1 MPa type		Vacuum pressure -101 kPa type		
PN	DPH-101(-R)	DPH-101-M3(-R)	DPH-101-M5(-R)	DPH-102	DPH-102-M5	DPH-103(-R)	DPH-103-M3(-R)	DPH-103-M5(-R)
Type of pressure	Gauge pressure							
Rated pressure range	-100.0 to +100.0kPa			0 to +1.000Mpa		0 to -101.0kPa		
Pressure resistance	500kPa			1.5Mpa		500kPa		
Applicable fluid	Air, non-corrosive gas							
Supply voltage	12 to 24VDC ± 10% Ripple P-P 10% or less							
Analog voltage output	Output voltage: 1 to 5V (overrated pressure range)							
Protection	IP40 (IEC)							
Ambient temperature	0 to +50°C (No dew condensation allowed), Storage: -10 to +60°C							
Ambient humidity	35 to 85% RH, Storage: 35 to 85% RH							
Pressure port	DPH-10x(-R): R1/8 male thread + M5 female thread, DPH-10x-M3(-R): M3 male thread (for installing gasket) DPH-10x-M5(-R): M5 male thread (for installing gasket)							
Rated current consumption	15mA or less							
Housing material	Front case: PBT, Rear case: PBT (glass fiber reinforced), Pressure port: Stainless steel (SUS303)							
Connecting method	Connector							
Physical size (HxWxL), mm	23x13.2x 23.4	17x10x 20.5	17.5x10x 20.5	17x10x 20.5	17.5x10x 20.5	17x10x 20.5	17.5x 10x 20.5	
Weight	Net weight: DPH-10x(-R): Head 10g approx. / Cable 40g approx., DPH-10x-M3/M5(-R): Head 6 g approx. / Cable 40g approx. DPH-10x(-R): 80g approx., DPH-10x-M3/M5(-R): 70g approx.							
Accessory	Connector (e-CON): 1pc.							

Controller		
Type	NPN output type	PNP output type
PN	DPC-101	DPC-101-P
Applicable sensor head	DPH-101x, DPH-102x, DPH-103x	
Rated pressure range	Compound pressure: -100.0 to +100.0kPa, Positive pressure: 0 to +1.000MPa, Vacuum pressure: 0 to -101.0kPa	
Supply voltage	12 to 24 VDC ± 10% Ripple P-P 10% or less	
Power consumption	Normal operation: 960mW or less (Current consumption 40mA or less at 24V supply voltage) ECO mode (STD): 720mW or less (Current consumption 30mA or less at 24V supply voltage) ECO mode (FULL): 600mW or less (Current consumption 25mA or less at 24V supply voltage) Excluding the current consumption of sensor head and analog output current	
Protection	IP40 (IEC)	
Ambient temperature	-10 to +50°C (No dew condensation or icing allowed), Storage: -10 to +60°C	
Ambient humidity	35 to 85% RH, Storage: 35 to 85% RH	
Material	Enclosure: PBT (glass fiber reinforced), LCD display: Acrylic, Mounting threaded part: Brass (nickel plated), Switch part: Silicone rubber)	
Ambient humidity	35 to 85% RH, Storage: 35 to 85% RH	
Connecting method	Connector	
Cable length	Total length up to 100m is possible with cable of 0.3mm ² or more	
Weight	Net weight: approx. 25g (excluding connector attached cable), Gross weight: approx. 140g	
Accessories	CN-66A-C2 (Cable (2m) with attached connector), Pressure unit label: 1 set	

DP2



DP2

High-performance digital pressure sensors

Features

High accuracy, high resolution, high speed

The DP2 series achieves a 2.5ms or less response time at a high resolution of 1/1,000. It enables highly accurate sensing with its excellent repeatability and temperature characteristics.

Clearly visible LED display with 3.5 digits

Bright red LED 7-segment display having 3.5 digits, 10mm high. The displayed figures are remarkably noticeable not only in a dark area, but also in a well-lit place.

Setting with easy key operation

Initialization and threshold value settings are easily done by key operation while seeing the values on the display.

Selection from six pressure units

The pressure unit can be selected from six different systems to suit your requirement.

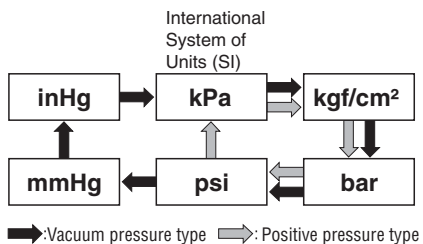

Four output modes enable versatile pressure level control

1) Hysteresis mode

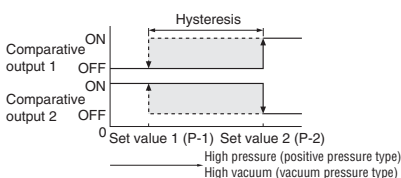

2) Window comparator mode

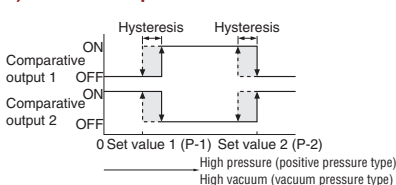

3) Dual output mode

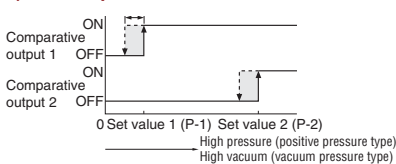

4) Automatic sensitivity setting mode

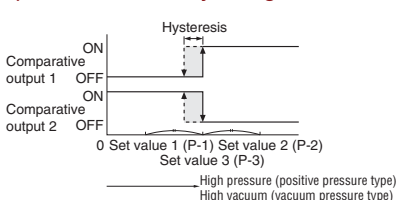

Technical Specifications

Type	Vacuum pressure				Positive pressure						
	- 101kPa type				100kPa type			1MPa type			
	Standard	Light weight	Flat	IP67	Standard	Flat	IP67	Standard	Flat	IP67	
Asian	DP2-20	DP2-80	—	DP2-60	DP2-21	DP2-41	DP2-61	DP2-22	DP2-42	DP2-62	
North American (Note)	DP2-20F (-P)	—	DP2-40N	DP2-60N	DP2-21F (-P)	DP2-41N	DP2-61N	DP2-22F (-P)	DP2-42N	DP2-62N	
European	—	—	DP2-40E	DP2-60E	—	DP2-41E	DP2-61E	—	DP2-42E	DP2-62E	
Type of pressure	Gauge pressure										
Rated pressure range	0 to -101.3kPa				0 to 100.0kPa			0 to 1.000MPa			
Applicable fluid	Non-corrosive gas										
Supply voltage	12 to 24VDC +10% / -15% Ripple P-P 10% or less										
Output	< Asian, North American (Standard NPN output, flat and IP67 types)> NPN open-collector transistor					< North American (Standard PNP output type), European> PNP open-collector transistor					
Analog voltage output	Output voltage: 1 to 5 V (over rated pressure range) Zero-point: within 1 V \pm 5% F.S. Span: within 4 V \pm 5% F.S. Linearity: within \pm 1% F.S. Output impedance: 1k Ω approx.										
Pressure port	Asian	Standard, Flat and IP67 types: Rc (PT) 1/8 female thread, Light weight type: M5 female thread									
	North American	Standard type: , NPTF 1/8 female thread, Flat and IP67 types: NPT 1/8 female thread									
	European	Flat and IP67 types: G (PF) 1/8 female thread									
Housing material	Front case: ABS, Rear case: PPS (glass fiber reinforced), Display surface: Acrylic Pressure port attachment: Die-cast zinc alloy (Light weight type: POM (glass fiber reinforced), pressure port is brass (nickel plated)) Front cover (IP67 type only): Polycarbonate										
Weight	Standard type: 95g approx., Flat type: 120g approx., IP67 type: 370g approx., Light weight type: 70g approx.										
Accessories	Hexagon-socket-head plug for pressure port: 1 pc. (Standard type only), Pressure unit label: 1 pc.										

Note: Model Nos. of North American standard type having the suffix "P" are PNP output type.

Typical Applications

Verifying proper workpiece seating

Air is supplied from under the base, and the pressure sensor checks for air leakage from any gap between the base and the workpiece.

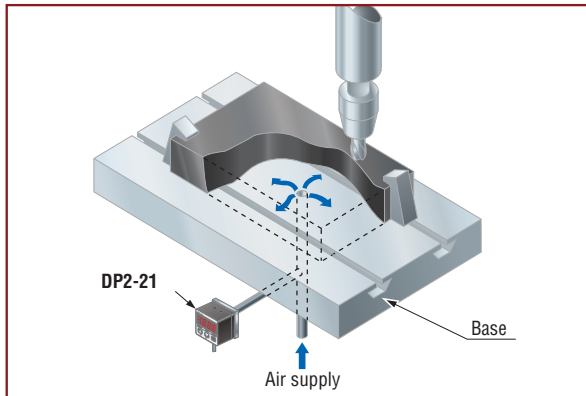

Detecting broken spool

The pressure sensor detects if a spool is chipped by sensing even slight air leakage in the air-supply system shown below.

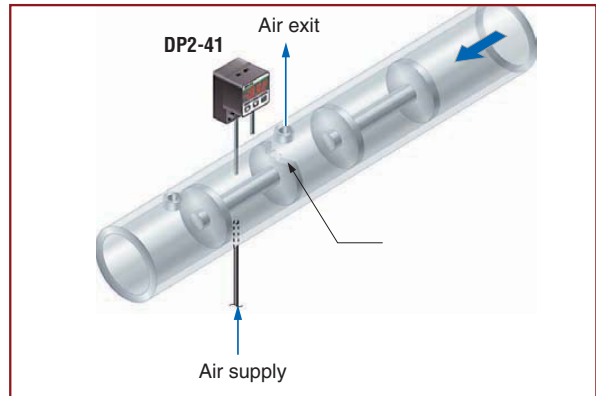

DP4



DP4

Suitable for panel installation due to new shape

Features

Lightweight, compact design

A compact form specifically designed for mounting on an equipment panel.

It uses only half the space of our conventional product and boasts the lightest weight of just 30g (cable excluded).



Supplied with a simple-to-mount panel mounting bracket

A panel mounting bracket (**MS-DP-1**) is enclosed to enable simple mounting of the sensor onto the panel surface, thus contributing to the total cost reduction.

Bright, easy-to-view 2-color digital display

The digital display is a large, easy-to-view 2-color digital display. It also functions as an output indicator as it changes from green to red when the output turns ON, enabling you to confirm the output status at a glance.

Typical Applications

Vacuum level confirmation for vacuum moulding

Detects the smallest air leaks from pinholes and other minute imperfections.

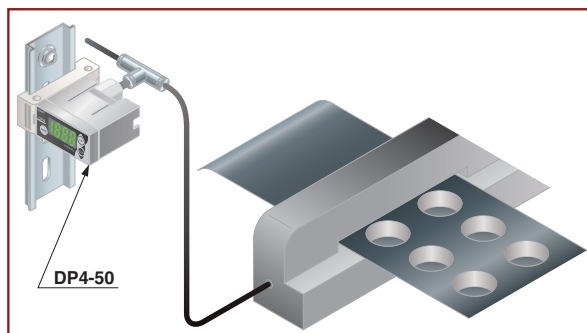

Confirming suction of wafer

While a wafer is being carried, the pressure sensor checks the vacuum level in the vacuum pad to verify that the wafer is being securely gripped.

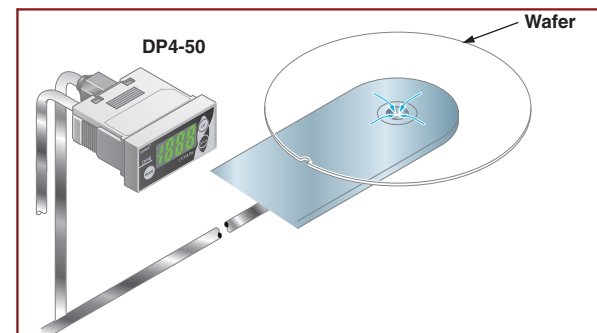

Technical Specifications

Type	Vacuum pressure		Positive pressure		Compound pressure	
	- 101kPa type		1MPa type		±100kPa type	
	NPN output	PNP output	NPN output	PNP output	NPN output	PNP output
PN	DP4-50	DP4-50P	DP4-52	DP4-52P	DP4-57	DP4-57P
Type of pressure	Gauge pressure					
Rated pressure range	0 to -101.3kPa		0 to 1.000MPa		-100.0 to 100.0kPa	
Applicable fluid	Non-corrosive gas					
Supply voltage	12 to 24VDC +10%/-15% Ripple P-P 10% or less					
Output	<NPN output type> NPN open-collector transistor			<PNP output type> PNP open-collector transistor		
Response time	2ms, 16ms, 128ms, 512ms or less (selectable by key operation)					
Protection	IP40 (IEC)					
Pressure port	M5 female thread					
Housing material	Front case: ABS, LCD display: PET, Rear case: PBT((M5 threaded part: Brass (nickel plated))					
Connecting method	Connector					
Weight	30g approx.					
Accessories	Panel mounting bracket (MS-DP-1): 1 set, Pressure unit label: 1 pc. Connector: 1 set (Housing: 1 pc., Connector pin: 3 pcs.)					

DP5/DPH



DP5/DPH

1/1000 second high-speed response

Response time 1ms

Mounting the detachable head close to the detecting section minimizes piping and enables response time of 1ms, as well as greatly decreasing tact time delay. In addition, the ultra small and lightweight design of the head means it can easily be mounted on moving sections.

Sensor head with operation indicator

The sensor head is also equipped with an operation indicator. Output ON/OFF can be checked on the sensor head, so that it is suitable for checking operation at the suction head.

Independent use of sensor head possible

Lightweight, compact design

The controller inherits its lightweight, compact design from the popular DP4 series of digital pressure sensors. Control panel setup is low cost and requires minimal space.

Convenient intermediate cable with connector

Intermediate cable with connectors for connecting the sensor head and the controller makes operation and maintenance easier.

Typical Applications

IC suction confirmation

With a light 6g head and a 1ms high-speed response time, it can be used with a high-speed mounter.



Verifying tightening of nut by impact wrench

The pressure sensor senses the back pressure of the impact wrench to verify that the nut is securely tightened.

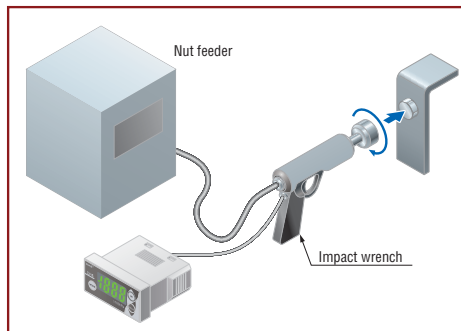

Verifying clamping pressure of welding hand

Since the pressure sensor incorporates two outputs, the clamping pressure can be classified into three levels: low, OK and high.

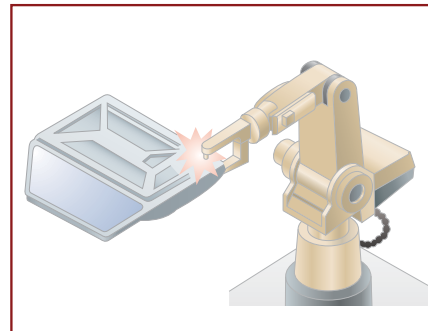

Technical Specifications

Type	Vacuum pressure				Positive pressure			Compound pressure		
	- 101kPa type				1MPa type			±100kPa type		
PN	DPH-A00	DPH-A10	DPH-A20	DPH-A30	DPH-A02	DPH-A12	DPH-A22	DPH-A07	DPH-A17	DPH-A27
Type of pressure	Gauge pressure									
Rated pressure range	0 to -101.3kPa				0 to 1.000MPa			-100.0 to 100.0kPa		
Applicable fluid	Non-corrosive gas									
Supply voltage	12 to 24VDC +10% /-15% Ripple P-P 10% or less									
Analog voltage output	<ul style="list-style-type: none"> • Output voltage: 1 to 5V (over rated pressure range) • Zero point: within 1V ± 2% F.S. (vacuum / positive pressure type) within 3V ± 3% F.S. (compound pressure type) • Span: within 4V ± 3.5% F.S. 									
Pressure port	DPH-A0□ : M5 female thread (for installing gasket), DPH-A1□ : R (PT) 1/8 male thread / M5 female thread DPH-A2□ : NPT 1/8 male thread / 10-32UNF female thread, DPH-A30 : 10-32UNF male thread (for installing gasket),									
Housing material	Enclosure: PBT, Pressure port: Brass (nickel plated) (however, stainless steel (SUS303) in case of DPH-A0□)									
Connecting method	Connector									
Weight	DPH-A0□ / DPH-A30 : 6g approx., DPH-A1□ / DPH-A2 : 10g approx.									
Accessories	Gasket (DPH-A0□ , DPH-A30 only)									

Type	NPN output type	PNP output type
PN	DP5-C	DP5-C-P
Applicable pressure sensor head	DPH-A00, DPH-A02, DPH-A07, DPH-A10, DPH-A12, DPH-A17, DPH-A20, DPH-A22, DPH-A27, DPH-A30	
Rated pressure range	Vacuum pressure: 0 to -101.3kPa, Positive pressure: 0 to 1.000MPa, Compound pressure: -100.0 to 100.0kPa	
Supply voltage	12 to 24VDC +10% /-15% Ripple P-P 10% or less	
Analog voltage output	<ul style="list-style-type: none"> • Output voltage: 1 to 5V (over rated pressure range) • Zero point: within 1V ± 2.5% F.S. (vacuum / positive pressure type) within 3V ± 3.5% F.S. (compound pressure type) • Span: within 4V ± 4% F.S. 	
Housing material	Front case: ABS, LCD display selection: PET, Rear case: PBT	
Connecting method	Connector	
Weight	20g approx.	
Accessories	Panel mounting bracket (MS-DP-1): 1 set, Connector: 1 set (Housing: 1 pc., Connector pin: 6 pcs.), Pressure unit label: 1 set., Connector cap: 1 pc.	

PRESSURE & FLOW SENSORS

DP-M



DP-M

Precisely detects minute differences in pressure levels

Features

High accuracy and resolution

Due to differential pressure sensing, the pressure can be set with a high resolution of 0.01kPa.D (1mm H₂O.D) over a pressure range of 0 to 2.00kPa.D (0 to 204mm H₂O.D) and, moreover, the detection accuracy is within 51% F.S.

Bright digital display

Three bright red 7-segment LEDs, 12mm high, are incorporated in the compact body.

Simple key setting

Initialization or pressure settings can be easily done with key operation while looking at the display.

Analog current output (4 to 20mA) incorporated DP-M2A is also available

Intermediate cable with connectors for connecting the sensor head and the controller makes operation and maintenance easier.

Technical Specifications

Type	Vacuum pressure		Positive pressure
	DP-M2		DP-M2A
PN			
Type of pressure	Differential pressure		
Rated pressure range	0 to 2.00kPa.D (0 to 204mmH ₂ O.D)		
Applicable fluid	Non-corrosive gas		
Supply voltage	12 to 24V DC +10% /-15% Ripple P-P 10% or less		
Analog current output	-		<ul style="list-style-type: none"> • Output current: 4 to 20mA (from 0 to 1.96kPa.D (0 to 200mmH₂O.D)) • Zero point: within 4mA ± 12% F.S. • Span: within 16mA ± 3% F.S. • Linearity: within ± 1% F.S.
Ambient temperature	0 to +50°C (No dew condensation), Storage: -10 to +60°C		
Ambient humidity	35 to 85% RH, Storage: 35 to 85% RH		
Pressure port	ø4.8mm resin pipe		
Housing material	Front case: ABS, Rear case: ABS, LED display: Acrylic, Pressure port: PA		
Connecting method	0.18mm ² 3-core oil resistance cabtyre cable, 2m long		0.18mm ² 4-core oil resistance cabtyre cable, 2m long
Weight	75g approx.		

CC Link

Network communication

Features

Network communication

With the CC-Link SC-GU2-C communication unit, you can connect to a CC-Link open network, allowing you to monitor or change settings via a PLC, PC, etc.

Ultra high-speed response time of 150µs

Independent dual outputs and 5 output modes

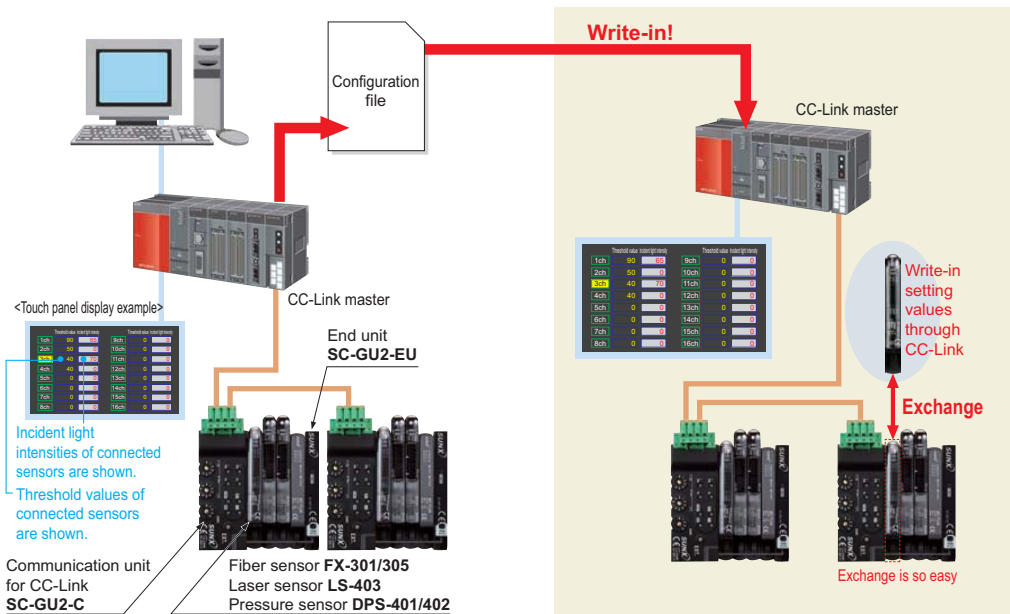

Features

Thin controller lineup

The DPS-400 series has answered industry's call to downsize pressure sensors at production sites and conveniently fit into most machines and reduction of man-hours when it comes to replacement.

Saves wire and space

Quick-connection cables not only reduce wiring, they reduce the time necessary for setting up relay terminals, and they save space. DPS-400 series controllers can be connected side-by-side with FX-300 series fiber sensors or LS series laser sensors.

Current value and threshold value can be checked simultaneously on the dual display

The controller is equipped with a 4-digit dual digital display, which allows you to adjust the threshold value while checking the current value (current pressure value), i.e. it is no longer necessary to switch screen modes.

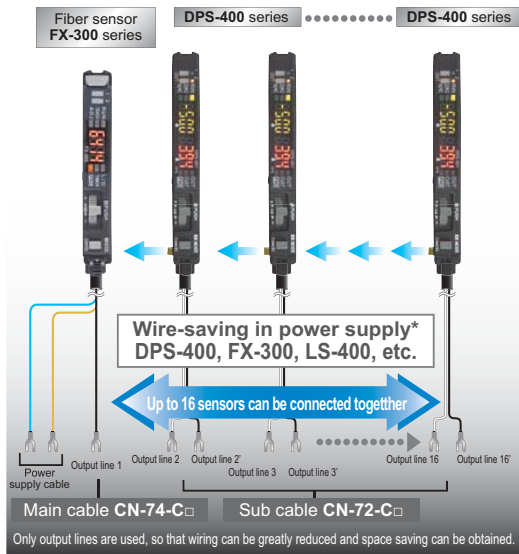

* Check the instruction manual of each model for the arrangement order such when connecting as communication varies depending on the model.

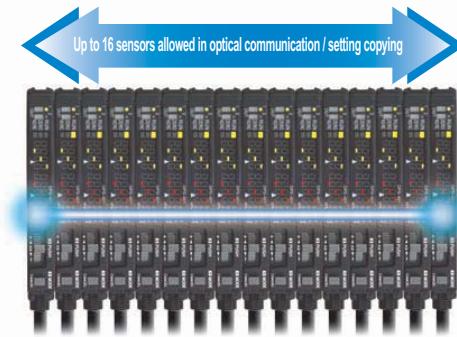

Network communication

With the CC-Link SC-GU2-C communication unit, you can connect to a CC-Link open network, allowing you to monitor or change settings via a PLC, PC, etc. Batch communication can even be executed when connected to FX-301/305 series digital fiber sensors or DPS-401/402 series digital pressure sensors.

Threshold tracking function

This function tracks changes in the light emitting amount over long periods, such as those caused by dust levels, and threshold values can be reset automatically, helping reduce maintenance costs.

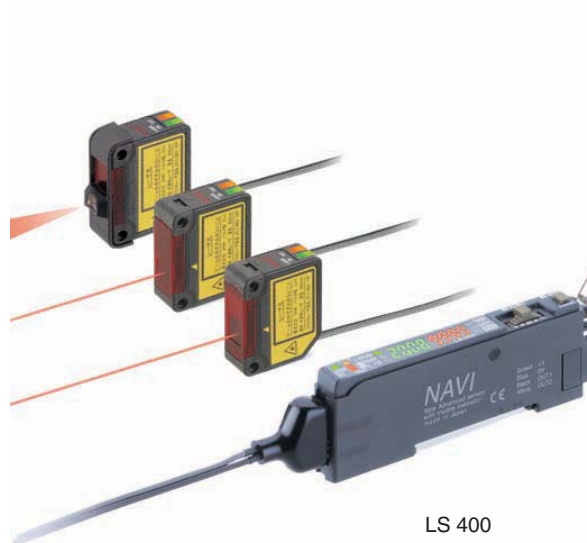



GX-F/H

Industry No. 1* in stable sensing

* Based on a research conducted by SUNX as of August 2007 among equivalent rectangular inductive sensors

Features

Environmental resistance

10 times the durability! (Compared to previous models)

This sensor has the longest stable sensing range among the same level of rectangular inductive proximity sensors in the industry. It is easy to install the sensor.

- Highly resistant to water or oil!
- Can be installed with ample space
- IP68g* protective construction

The new, integrated construction method improves environmental resistance performance.

*The IP68g prevents damage to the sensor by stopping water and oil from getting inside.

Indicators are easy to see over a wide field of view

A prism with a wide field of view has been developed, thereby greatly improving the visibility of the operation indicators.

Typical Applications

Checking up/down operation of compact molding equipment

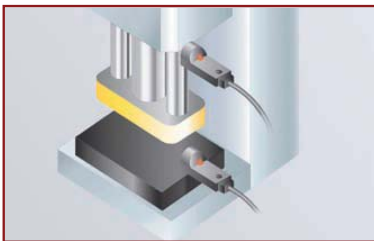

Shock resistance: 5000G

Sensing presence of metallic objects on a part feeder



Vibration resistance: 500Hz

Positioning metal pallets

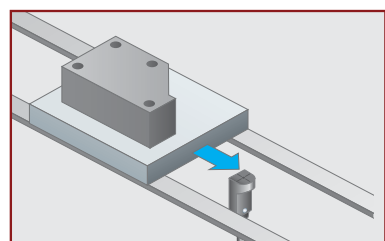

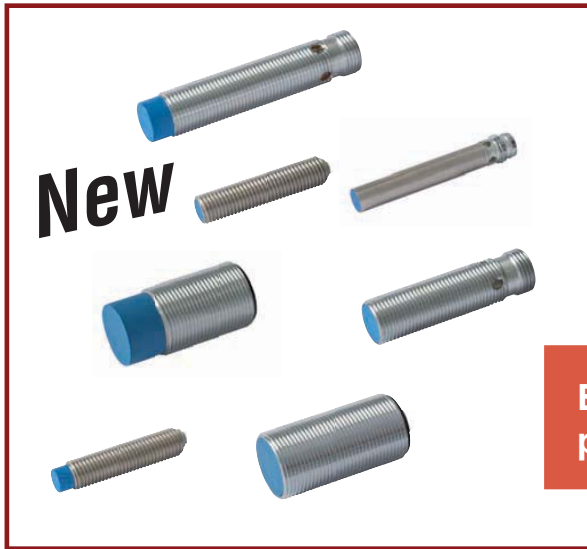

GX-S

Easy-to-use, cylindrical proximity sensors

Features

Variety

- Stainless steel or chrome plated brass housings
- PNP or NPN output
- Cylinder or thread types
- Connection or cable types

Cost effective

- With a widely used M8/M12/M18
- Cylindrical shape housing means quick and easy installation

Typical Applications

Controlling depth of drilling

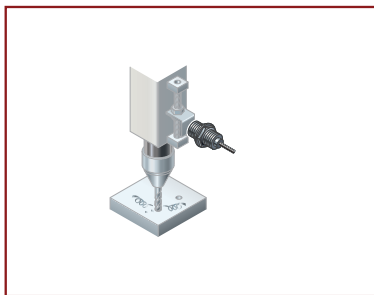

Sensing the punch of a die

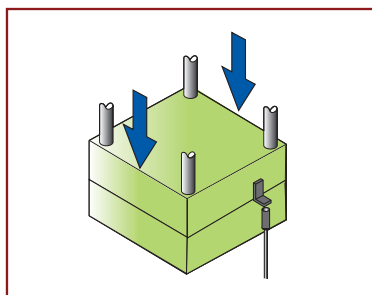

Counting parts

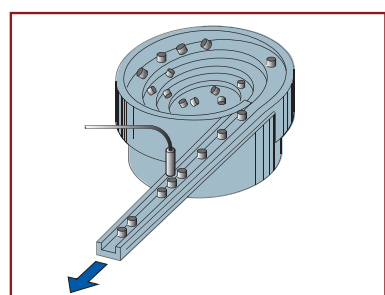

GX-S Technical Specifications

	GXS-E015-DV2-(P/)(J/Z/)	GXS-E020-DV2-(P/)(J/Z/)	GXS-E015-CV2-(P/)(J/Z/)	GXS-E020-CV2-(P/)(J/Z/)	GXS-N025-CV2-(P/)(J/Z/)	GXS-E020-BBCS-(P/)(Z/)	GXS-E020-BBC-(P/)(Z/)	GXS-N040-BBC-(P/)(Z/)	GXS-N040-BBBS-(P/)(Z/)
Mounting	Embedable	Embedable	Embedable	Embedable	Non-embedable	Embedable	Embedable	Non-embedable	Non-embedable
Sensor type	Cylinder type	Cylinder type	Thread type	Thread type	Thread type	Thread type	Thread type	Thread type	Thread type
(Ø in mm)	Ø 6.5	Ø 6.5	M8	M8	M8	M12	M12	M12	M12
Maximum operating distance	1.5mm +10%	2.0mm ±10%	1.5mm ±10%	2.0mm ±10%	2.5mm ±10%	2.0mm ±10%	2.0mm ±10%	4.0mm ±10%	4.0mm ±10%
Stable sensing range	0 - 1.2mm	0 - 1.6mm	0 - 1.2mm	0 - 1.6mm	0 - 2.0mm	0 - 1.6mm	0 - 1.6mm	0 - 3.2mm	0 - 3.2mm
Detection frequency	5kHz	3kHz	5kHz	3kHz	3kHz	3kHz	3kHz	2kHz	2kHz
Standard	Steel	Steel	Steel	Steel	Steel	Steel	Steel	Steel	Steel
Detectable object	6.5x6.5x1mm	6.5x6.5x1mm	8.0x8.0x1mm	8.0x8.0x1mm	8.0x8.0x1mm	12.0x12.0x1mm	12.0x12.0x1mm	12.0x12.0x1mm	12.0x12.0x1mm
Supply voltage	±20%								
Hysteresis	Max. 15% of maximum operating range								
Output transistor	Max. 200mA								
Current consumption	Max. 10mA								
Housing material	Stainless steel					Chrome plated brass			
Protection	IP67								
Connection	J=Connector M8 Z=Connector M12=cable2m								

P=PNP =NPN J=Connector M8 Z=Connector M12=cable2m

	GXS-E040-BBC-(P/)(Z/)	GXS-E040-BBBS-(P/)(Z/)	GXS-E050-ABC-(P/)(Z/)	GXS-E050-ABCS-(P/)(Z/)	GXS-N080-ABC-(P/)(Z/)	GXS-N080-ABCS-(P/)(Z/)	GXS-Q080-ABC-(P/)(Z/)	GXS-Q080-ABCS-(P/)(Z/)
Mounting	Embedable	Embedable	Embedable	Embedable	Non-embedable	Non-embedable	Quasi-embedable	Quasi-embedable
Sensor type	Thread type	Thread type	Thread type	Thread type	Thread type	Thread type	Thread type	Thread type
(Ø in mm)	M12	M12	M18	M18	M18	M18	M18	M18
Maximum operating distance	4.0mm ±10%	4.0mm ±10%	5.0mm ±10%	5.0mm ±10%	8.0mm ±10%	8.0mm ±10%	8.0mm ±10%	8.0mm ±10%
Stable sensing range	0 - 3.2mm	0 - 3.2mm	0 - 4.0mm	0 - 4.0mm	0 - 5.4mm	0 - 5.4mm	0 - 5.4mm	0 - 5.4mm
Detection frequency	2.5kHz	2.5kHz	2kHz	2kHz	1.4kHz	1kHz	1kHz	1kHz
Standard	Steel	Steel	Steel	Steel	Steel	Steel	Steel	Steel
Detectable object	12.0x12.0x1mm	12.0x12.0x1mm	18.0x18.0x1mm	18.0x18.0x1mm	24.0x24.0x1mm	24.0x24.0x1mm	24.0x24.0x1mm	24.0x24.0x1mm
Supply voltage	10 to 30VDC ±20%							
Hysteresis	Max. 15% of maximum operating range							
Output transistor	200mA							
Current consumption	Max. 10mA							
Housing material	Chrome plated brass							
Protection	IP67							
Connection	J=Connector M8 Z=Connector M12=cable2m							

P=PNP =NPN J=Connector M8 Z=Connector M12=cable2m



GP-X

High-speed sampling 25 μ s and high resolution 0.02% eddy current type

Features

We have realized a 25 μ s (40,000 times/sec.) ultra high sampling speed

These devices boast 0.07% F.S./7C temperature characteristics

They perform with a $\pm 0.3\%$ F.S. linearity for stainless steel and iron

Because they perform with a $\pm 0.3\%$ F.S. linearity, they can be used for sensing stainless steel and iron, enabling precise measurements not affected by the workpiece's material.

Intelligent monitor GP-XAiM (optional) optimal for collecting and analyzing measurement data

The 5-digit, dual, 2-color digital display offers great visibility

If the measurement results fall within the setting range (GO), they will appear on the lower digital display in green. If they are out of range (HI, LO), they will be displayed in the upper digital display in orange. The display position and color change permit accurate visibility even for momentary changes.

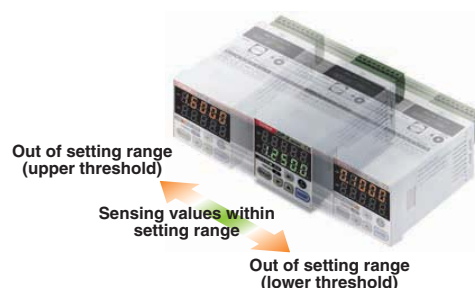

Technical Specifications

Sensor heads

Model no.	GP-X3SE	GP-X5SE	GP-X8S	GP-X10M	GP-X12ML	GP-X22KL
Sensing range	0 to 0.8mm	0 to 1mm	0 to 2mm	0 to 2mm	0 to 5mm	0 to 10mm
Standard sensing object	Stainless steel (SUS304)/iron sheet 60×60×1mm					
Ambient temperature	-10 to +55°C					
Dimensions (mm)	∅3.8×17	∅5.4×17	∅8×17	M10×17	M12×21	∅22×35

Controller

Set model no.	NPN output type GP-XC□, PNP output type GP-XC□-P
Supply voltage	24VDC $\pm 10\%$
Resolution	(64 times average processing): GP-XC3SE/XC5SE 0.04% F.S. GP-XC8S/XC10M/XC12ML/XC22KL 0.02% F.S.
Analog voltage output:	Output voltage 15 to +5V
Comparative outputs (HI, GO, LO)	GP-XC□ NPN open-collector transistor GP-XC□-P PNP open-collector transistor
Dimensions (mm)	W48×H48×D83

LM-10



LM-10

The entrance model in μm resolution distance measurement

High-precision measurements, comparative output (amount of light / displacement) function

In addition to conventional analog output, it is equipped with standard ON/OFF control output (single /double comparator) enabling its use as a photoelectric sensor. It is compatible for 'micro-spotting' and 'high-precision' applications normally reserved for lasers.

Laser class 1, visible red light version

The LM-10 series is the newest generation of laser sensors and offers excellent performance. The new single channel technology and the automatic gain adjustment allow high resolution measurements at a wide dynamic range. The LM-10 series is especially suitable for accurate thickness, displacement and position measurements.

Laser class 2, visible red light version

The LM-10 series also includes a wide range of class 2 sensor heads which offer an even smaller resolution. Also a long distance type with a measuring range from 100mm to 400mm is available. The cable length of all class 2 types is expandable to up to 30m.

LCD display for analog values and set points (double comparator type)

In addition to the analog output, the LM-10 controllers have one (single comparator type) or two (double comparator type) set-point judgement outputs. The double comparator type shows the analog values on an LCD.

Technical Specifications

Sensor heads

Type	ANR1250	ANR1251	ANR1282	ANR1215	ANR1226
Laser class	2				
Measurement range (mm)	50 ± 10	50 ± 10	80 ± 20	130 ± 50	250 ± 150
Beam dimensions (mm)	0.6 x 1.1	0.09 x 0.05	0.7 x 1.2	0.7 x 1.4	0.8 x 1.5
Response frequency	10/100/1000Hz				
Resolution (µm)	1/3.5/10	1/3.5/10	4/13/40	20/65/200	150/500/1500
Laser wavelength	685nm				
Lasser class	1				
Max. output of laser diode	1.6mW				
Housing material	Zinc die cast				
Degree of protection	IP67				
Size	60 x 60 x 20mm				
Connection method	Connector				
Ambient temperature	0°C to +50°C				
Weight (approx.)	300g				

Controllers

NPN output	ANR5131	ANR5141	ANR5231	ANR5241
PNP output	ANR5132	ANR5142	ANR5232	ANR5242
Type	Single comparator		Double comparator	
Indication	LED		LCD display	
Analog output	± 5V, max. 100mA	4 - 20mA	± 5V, max. 100mA	4 - 20mA
Evaluation output	Transistor, max. 100mA, 30V DC			
Intensity output	± 5V			
Alarm output	Transistor, max. 100mA, 30V DC			
Housing material	Plastic			
Size	35 x 96 x 55mm			
Connection method	Cable			
Operating voltage	12 to 24 V DC (-15% / +10%)			
Ambient temperature	0°C to +50°C			
Weight (approx.)	180g			

Typical Applications

Measuring packing tape thickness

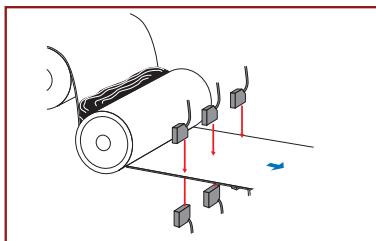

Slack detection

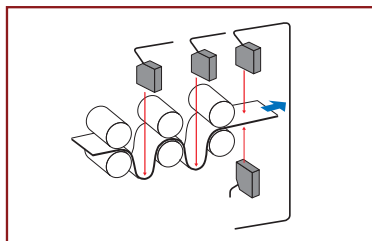

Asymmetry detection

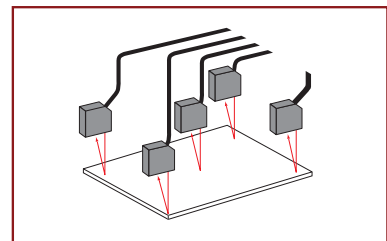

HL-C1



HL-C1

Ultra high-speed & stable measurement for a variety of measurement objects

Features

100µs of sampling rate is now available

The most amazing, ultra high-speed sampling in the industry has now been achieved for displacement sensors utilizing linear image sensors, thus enabling ultra high-speed measurement of rotating, vibrating and moving objects.

Resolution of 1µm, linearity of ±0.1% F.S.

Now available with ultra-precise 1µm resolution measurement capability (HL-C105B-BK, HL-C105F-BK, HL-C105B, HL-C105F) and a linearity of ±0.1% F.S. (for all models).

Touch panel operation, easy and compact

A variety of setting and measurement data can be displayed easily (optional).



High accuracy measurement is now possible, unaffected by the surface condition of the detected object

All deficiencies inherent in the conventional PSD sensing method have now been completely solved. Whereas the PSD method measures position information from the center of gravity of the total light quantity distribution of the light spots connected along each light element, the linear image sensing method measures the peak position values for the light spots themselves. This advance now makes high-precision measurement possible, regardless of the surface condition of the object, whether for metal hairline surface cracks or for non-reflective surfaces, e.g. black rubber.

Two sensor heads can be connected! Reduces costs and saves space

Controller compact and front connection reduces setup space

The ultra compact controller with dimensions of W40×H120×D74mm requires extremely little space for installation. Adhesive installation is also possible. Furthermore, the cables can be connected directly or to a removable terminal block, so that all connections come from the same direction in order to further save space.

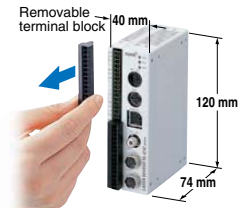

Equipped with serial input/output

An RS 232C interface for serial input and output is provided so that settings can be retrieved and saved.

Measurement values can also be retrieved.

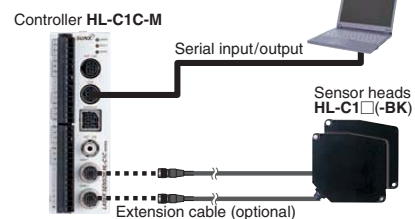

FDA standards conforming types are available

Special version for measurement of raw and completed rubber tire

The HL-C1 series has added a new line of tire measuring specialized versions for tire making processes.

The high-powered 5mW type enables high accuracy and stable measurement of raw tires and completed tires which were previously considered difficult to measure.

Typical Applications

Measuring glass substrate thickness

The HL-C1 series specular reflective type realizes stable distance measurements even for specular and transparent objects.

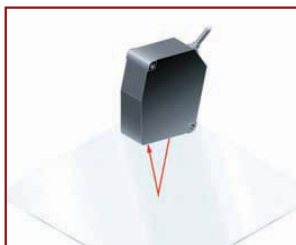

Detecting the presence of a resin coating

The HL-C1 series detects translucent resin coating.

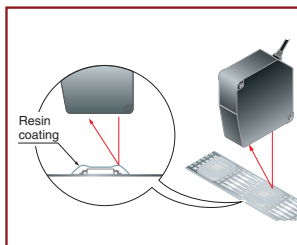

Measuring the eccentricity of a metal shaft

By using the filter function, it can quickly and stably measure even workpieces with tiny scratches.



Technical Specifications

Sensor heads

Type	Diffuse reflective		Specular reflective	
	General propose	High accuracy	General propose	High accuracy
Model no. (Note 1)	HL-C108B(F)-BK	HL-C105B(F)-BK	HL-C108B(F)	HL-C105B(F)
Measurement center distance	85mm	50mm	81.4mm	46mm
Measuring range	±20mm	±5mm	±16mm	±4mm
Resolution (Note 2)	2μm	1μm	2μm	1μm
Linearity	±0.1%F.S.			
Emitting element	Red semiconductor laser, Class 2 (class II for FDA standards conforming type)(IEC/JIS standards conforming type: IEC / JIS, FDA standards conforming type: JIS / IEC / FDA)(Max. output: 1 mW, Peak emission wavelength: 685 nm)			
Beam diameter	100×140μm approx.	70×120μm approx.	100×140μm approx.	70×120μm approx.
Protection	IP67 (excluding connector)			
Ambient temperature	0 to +45°C			
Dimensions (W×H×D)	26.6×82×87mm			

Notes: 1) HL-C10□B(-BK) is IEC / JIS standards conforming type.
 HL-C10□F(-BK) is FDA standards conforming type.
 2) Where measurement conditions have not been specified precisely, the conditions used were as follows: supply voltage 24VDC, ambient temperature +20°C, sampling rate 100μs, average number of samples: 256, measurement center distance, object measured is made of white ceramic (an aluminum vapor deposition surface reflection mirror was used with specular reflective type). Linearity also depends upon the characteristics of the object being measured.

Controller

Model no.		HL-C1C-M
Connectable sensor head		Max. 2 sensor heads
Supply voltage		24VDC±10%
Sampling rate		Selectable from 100μs / 144μs / 200μs / 255μs / 332μs / 498μs / 1000μs
Analog output	Voltage	Output voltage ±5 V/VS, Output current: Max. 2mA Output impedance: 50Ω
	Current	Output current: 4 to 20mA/F.S., Load resistance: 250Ω or less
	Output range	Voltage: 110.9 to +10.9V, Current: 0 to 29.5mA
Judgment outputs (O1, O2)		PhotoMOS relay
Average number of samples		OFF, 2 to 32,768 cycles (switching in 16 steps)
Ambient temperature		0 to +50°C
Dimensions (mm)		W40×H120×D74

HL-C135C-BK10



HL-C135C-BK10 HL-C1C-M-WL

Superlative wide-range measurement with small head

Features

Measures wide changes over long ranges

The long-range and wide-range capabilities over **350mm** $\pm 200\text{mm}$ allow large changes to be measured. Even if the object's position changes, there is no need to change the sensor head settings or position.

High-speed and high-precision even over long and wide ranges

High-speed and high-precision measurement is possible with high-speed sampling of **100 μs** at a resolution of **10 μm** and a linearity of $\pm 0.1\%$ F.S.



Sensor heads

Measurement center distance	350mm
Measuring range	$\pm 200\text{mm}$
Emitting element	Red semiconductor laser, Class 3B (IEC/JIS)
Beam diameter	400 \times 200 μm approx.
Controller	Specifications are the same as for the HL-C1C-M controller on the previous page
Dimensions (mm)	W48 \times H48 \times D83

Typical Applications

Measuring brake disk thickness

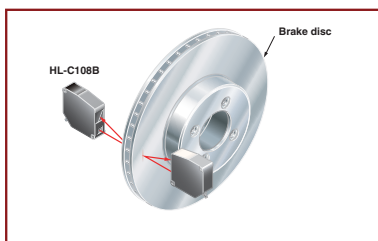

Inspecting tire form



Measuring the thickness of a rubber sheet

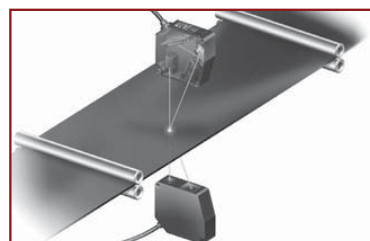



New

Ultra high-speed, precision laser displacement sensors

Features

Excellent basic performance

10 μ s sampling rate available

The HDLC-CMOS sensors have been developed especially for the HL-C2 series. High density light-receiving cells and a processing speed close to the maximum limit result in resolutions and speeds that exceed all expectations for laser displacement sensors.

Resolution up to 0.01 μ m, linearity up to $\pm 0.02\%$ F.S

Superior resolution of 0.01 μ m. Linearity of $\pm 0.02\%$ F.S enabled by latest high resolution lens technology.



Touch panel simplifies operation

Measurement values and wavelength of the light intensity are displayed. Via the menu, you can set the sensor head function and output conditions.



Compact sensor head saves space

The volume ratio has been reduced by 23% compared to the previous model, minimizing installation space.



Compact but with a wide array of functions

You can connect two sensor heads and a variety of devices to the ultra compact controller. Measurement values can be analyzed and displayed while the sensors are being controlled.



Detection tolerance improved for tilted objects

Detection tolerance for tilted objects has increased by 50% over the previous model, allowing you more flexibility in applications in which the position of the object being sensed fluctuates.

HL-C2 Typical Applications

Measurement of the position of patterned glass

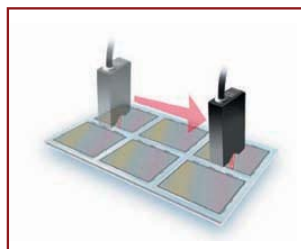

Control of the camera focus



Measurement of the shape of a camshaft



Measurement of the heights of chip parts



Technical Specifications

Model no.	Sensor heads						
	HL-C201F[E]	HL-C203F[E]		HL-C211F[E]		HL-C211F5[E]	
Type	Small beam spot type						
	Specular reflective	Diffuse reflective	Specular reflective	Diffuse reflective	Specular reflective	Diffuse reflective	Specular reflective
Laser class	1	2			3R		
Measuring range	10 ± 1mm	30 ± 5mm	26.4 ± 4.6mm	110 ± 15mm	106.7 ± 14.5mm	110 ± 15mm	106.7 ± 14.5mm
Beam diameter	ø20µm	ø30µm	ø30µm	ø80µm			
Sampling frequency	up to 100kHz						
Resolution	0.01µm	0.025µm	0.25µm	0.1µm	0.25µm	0.1µm	0.25µm
Laser wavelength	658nm						
Max. power of the emitting element	0.1mW	1mW		5mW			
Housing material	Die-cast aluminum						
Protection	IP67						
Physical size (HxWxL)	54 x 95 x 20mm	80 x 70 x 26mm			95 x 54 x 20mm		
Cable	0.5m with connector						
Ambient temp.	0°C to +45°C						
Ambient humidity	35 to 85% RH, Storage: 35 to 85% RH						
Weight (approx.)	250g (including cable)			300g (including cable)			
	[E] = Reduced resolution types						

Technical Specifications

Model no.	Sensor heads (linear beam spot type)						
	HL-C201F[E]-MK	HL-C203F[E]-MK		HL-C211F[E]-MK		HL-C211F5[E]-MK	
Type	Linear beam spot type						
	Specular reflective	Diffuse reflective	Specular reflective	Diffuse reflective	Specular reflective	Diffuse reflective	Specular reflective
Laser class	1	2				3R	
Measuring range	10 ± 1mm	30 ± 5mm	26.4 ± 4.6mm	110 ± 15mm	106.7 ± 14.5mm	110 ± 15mm	106.7 ± 14.5mm
Beam diameter	20 x 700µm	30 x 1200µm		80 x 1700µm			
Sampling frequency	up to 100kHz						
Resolution	0.01µm	0.025µm	0.25µm	0.1µm	0.25µm	0.1µm	0.25µm
Laser wavelength	658nm						
Max. power of the emitting element	0.1mW	1mW		5mW			
Housing material	Die-cast aluminum						
Protection	IP67						
Physical size (HxWxL)	54 x 95 x 20mm	80 x 70 x 26mm		95 x 54 x 20mm			
Cable	0.5m with connector						
Ambient temp.	0°C to +45°C						
Ambient humidity	35 to 85% RH, Storage: 35 to 85% RH						
Weight (approx.)	250g (including cable)			300g (including cable)			
[E] = Reduced resolution types							

Model no.	Controllers	
	HL-C2C	HL-C2C-P
Type	Controller (NPN) for up to 2 HL-C2 sensor heads	Controller (PNP) for up to 2 HL-C2 sensor heads
Analog output	±10.8V, 1-25mA	
Outputs	Alarm, judgment, strobe, max. 100mA 30VDC	
Inputs	Timer, zero set, remote interlock, reset 12 to 24VDC	
USB interface	USB 2.0	
Serial input/output	RS-232C (300 - 19.200bps)	
Current consumption	With 1 sensor head: 350mA With 2 sensor heads: 500mA	
Housing material	Die-cast aluminum	
Physical size (HxWxL)	105.5 x 120 x 59mm	
Connection method	Input terminal	
Supply voltage	24VDC (±10%)	
Ambient temp.	0°C to + 50°C	
Temperature characteristics	±0.01% F.S. (25°C)	
Weight (approx.)	450g	

HL-T1



HL-T1

A high-functionality intelligent controller

Features

Small sensor head

The most compact size and yet the highest level of performance in their class. These sensors save space.

Resolution of 4μm

A high resolution of 4μm (at an average 64 cycles) allows high-precision positioning and size judgment.

High-precision measurement even of minute differences in light intensity

The sensors are sensitive to minute differences in light intensity so that they can judge even the opacity of glass and turbidity of liquids. In addition, the amount of light received can be displayed as a percentage to allow you to determine permeation rates.

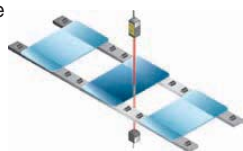

Distinguishing opacity of glass

Calculations for 2 sensors are possible

The calculation unit (optional) just needs to be connected between the two controllers to enable calculations (addition and subtraction) to be carried out for two sensors. No digital panel controller is needed.

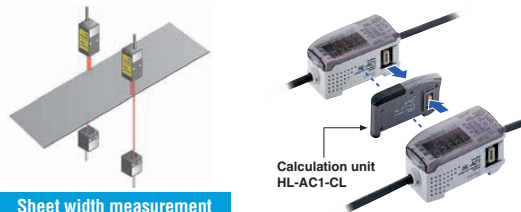

Sheet width measurement

FDA standards conforming types are available

FDA standards conforming types, most suitable for equipment used in the USA, are now available (FDA: class II, IEC/JIS: class 1).

Technical Specifications

Sensor heads

Type	Beam diameter \varnothing 1mm type	Sensing width 5mm	Sensing width 10mm type
Model no. (Note 1)	HL-T1001A(F)		HL-T1010A(F)
Sensing range	0 to 500mm	500 to 2000mm	500mm
Sensing width	\varnothing 1mm	\varnothing 1 to \varnothing 2.5mm	5mm / 10mm
Min. sensing object	\varnothing 8μm opaque object	\varnothing 50μm opaque object	\varnothing 0.05mm opaque object / \varnothing 0.1mm opaque object
Repeatability (during the state in which light is half blocked)	4μm (Note 2)	-	4μm (Note 2)
Linear output resolution	4μm (Note 2)	-	4μm (Note 2)
Ambient temperature	0 to +50°C		
IEC/JIS standards	Red semiconductor laser, Class 1 (IEC/JIS) [modulated, max. output 0.35mW (HL-T1001A(F): 0.2mW), emission peak wavelength: 650nm]		
FDA standards conforming type	Red semiconductor laser, Class 2 (FDA) [modulated, max. output 0.35mW (HL-T1001A(F): 0.2 mW), emission peak wavelength: 650nm] (IEC/JIS: class 1)		

Notes: 1) HL-T10MA is IEC/JIS standards conforming type.
HL-T10MF is FDA standards conforming type.
2) With an average sampling rate of 64 times.

Controllers

Type	NPN output	PNP output
Model no.	HL-AC1	HL-AC1P
Supply voltage	12 to 24VDC \pm 10%	
Measuring cycle	150μs	
Linear output	Current / voltage output switchable • During current output: 4 to 20mA/F.S., max. load resistance 300Ω • During voltage output: 54V/F.S., output impedance 100Ω (In the monitor focus function, it can also be set at 55V, 0 to 5V, etc.)	
Temperature characteristics	\pm 0.2% F.S./°C	
Settable average sampling rate	1 / 2 / 4 / 8 / 16 / 32 / 64 / 128 / 256 / 512 / 1024 / 2048 / 4096	
Judgment output (HIGH, PASS, LOW)	NPN open-collector transistor	PNP open-collector transistor
Ambient temperature	0 to +50°C	
Dimensions (mm)	W30×H34.3×D64.3	



ER-F Series

Low-volume fan type

Two exchangeable louvers to suit your needs

- Just simply replace the louver to change configuration between long distance and wide area ionization.
- The two louvers come with the ionizer main body.

Remove the louver for effortless maintenance

- Because the discharge needle unit is attached to the louver, exchange or maintenance of the needles is made easy without touching the main unit.
- A safe design where once the louver is removed, the high-voltage circuit and the fan will halt.

Straight louver



Removes charges quickly at long distance

Angle louver



Removes charges completely in wide area



ER-F Series **Technical Specifications**

Type	Standard fan type	Low-volume fan type
Model no.	ER-F12	ER-F12S
Charge removal time	1 sec. approx. (Note 1)	1.5 sec. approx. (Note 1)
Ion balance	±10 V or less (Note 2)	
Power supply voltage	24 V DC ±10%	
Power consumption	700 mA or less	400 mA or less
Discharge method	High-frequency AC method	
Discharge output voltage	± 2 kV approx.	
Max. fan speed	5.3 m/s (Note 2)	4.0 m/s (Note 2)
Max. fan volume	3.68 m ³ /min	2.50 m ³ /min
Main functions	Error output, Discharge halt input	
Indicators	Discharge error (Red), Fan error (Red), Power (Green), Discharge (Green)	
Ozone generation amount	0.04 ppm or less (Note 1)	
Ambient temperature	0 to +50°C (No dew condensation) / Storage: -10 to +65°C	
Ambient humidity	35 to 65% RH (No dew condensation) / Storage: 35 to 65% RH	
Grounding method	C (capacitor) grounding	
Material	Enclosure: ABS, Louver: ABS, Discharge needle unit: PBT Discharge needle: Tungsten, Bracket: SPHC	
Weight	Main unit: 790 g approx.	
Accessories	Straight louver: 1 pc. (Note 3), Angle louver: 1 pc. Caution label: 1 set, Rubber cushion: 1 pc.	

- Notes: 1) Typical value at 200 mm from directly in front of air outlet, fan speed MAX, straight louver, with no filter installed.
 2) Typical value at 300 mm from directly in front of air outlet, fan speed MAX, straight louver, with no filter installed.
 3) The discharge needle unit is loaded on the straight louver before shipment.

ER-TF



Wide-area ionizer

Flexible layout

The air blowing direction can be easily adjusted even after installation.

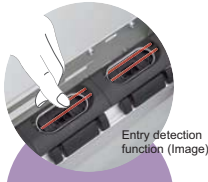

Safe design

Detection of entry to the discharger interrupts the high voltage circuit.

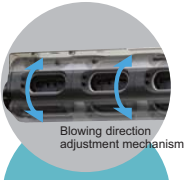

Easy maintenance

Discharge needle units can be detached or attached quickly by sliding open the cover.



Easy filter cleaning

The fan air intake filter can be easily removed. This greatly reduces the time needed for cleaning.



Airflow can be set to 4 different speeds

Fan can be set to 4 different speeds. The MAX setting quickly removes static charge over a wide area.



The new, wide-area ionizer from SUNX provides you with a new opportunity to effectively remove static from your production line. ER-TF ionizers are safe in design, easy to maintain and come in a variety of sizes to meet your workstation requirements. Moreover, there is no need for compressed air, which makes installation easy and keeps costs under control.

Problems with cell production lines

Up until now ionizers had not been able to fully meet the needs for on-site work.

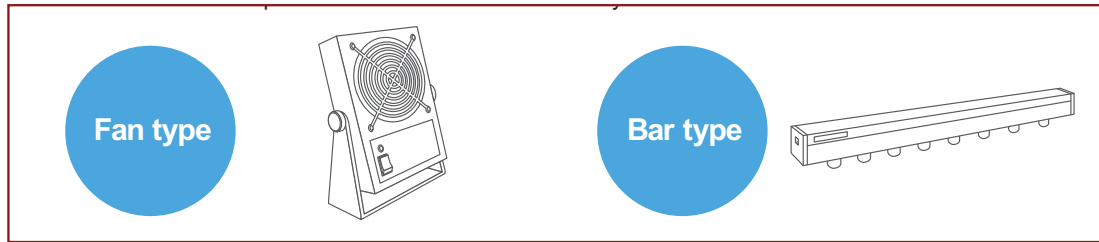

- One unit is not enough to cover the working area.
- Must be located near your hands for effective static removal.
- Two units take up too much space on the workbench.
- Compressed air is costly.
- Complicated piping makes layout change troublesome.
- Disturbance of airflow or contact with discharger decreases work efficiency.

Characteristics of ER-TF series

A style not seen before that pursues performance in cell production lines and resolves dissatisfaction with existing ionizers.

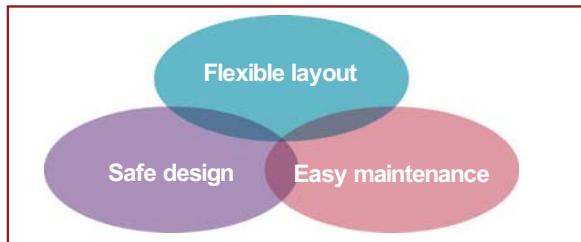

Typical Applications

Desktop setup, 800mm type to accommodate wide workbench

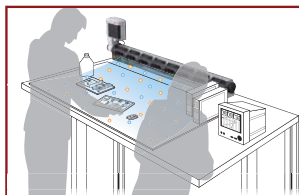

Front setup, 400mm type to suit operation space

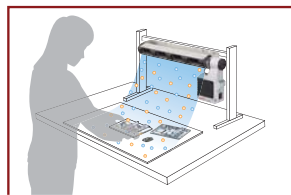

Overhead setup, 600mm type to cover cell production

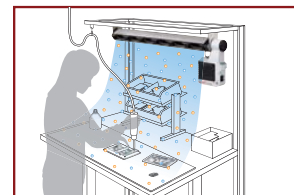

Technical Specifications

Model no.	Wide-area fan type		
	ER-TF04-EX	ER-TF06-EX	ER-TF08-EX
Type			
Charge removal time ($\pm 1,000V \rightarrow \pm 100V$)	Approx. 1s (Note 1)		
Ion balance	$\pm 10V$ or less (Note 2)		
Supply voltage	Accessory AC adapter input: 100 to 240VAC $\pm 10\%$ 50/60Hz (Output: 24VDC)		
Ambient temperature	0 to + 50°C (No dew condensation), AC adapter: 0 to + 40°C		
Material	Bar unit enclosure: ABS, Fan unit enclosure: ABS, Discharge needles: Tungsten, Mounting bracket: SPCC		
Weight (approx.)	Net weight: 1.0kg	Net weight: 1.2kg	Net weight: 1.4kg

Notes: 1) Typical value at a distance of 200mm from the front surface of the air outlet at the unit center at maximum fan speed.

2) Typical value at a distance of 300mm from the front surface of the air outlet at the unit center at maximum fan speed.

ER-VW



Nozzle angle adjustment and joint layout can be selected as desired

Features

Nozzle angle adjustment mechanism

The angles of the two nozzles can be adjusted within a range of approximately 190° by screwing down the ends of the nozzles. After adjusting the angle, turn the ends of the nozzles to tighten them and secure them at that angle. This allows the nozzle angles of the ER-VW to be adjusted easily after installation.

Installation examples

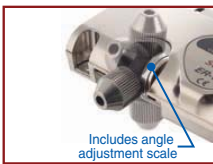
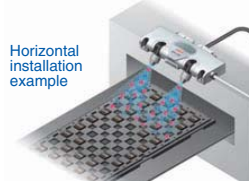
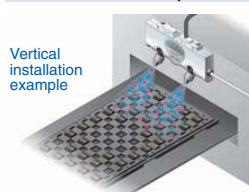

Compact and ultrathin design

The thickness of the unit is 18.9mm. Even so, the nozzle angles can be adjusted so that they can still be installed in places where there are space restrictions such as inside other equipment or along several adjacent production lines.

Minimum air consumption 15ℓ/min. (ANR)

ER-VW can utilize air flow levels starting from a minimum of 15ℓ/min. Because the amount of air consumed is so low, the loads placed on air supply equipment can be reduced and costly clean air can be used much more economically.

Comparison of air consumption

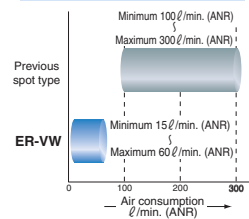

Air supply monitoring function

This function causes discharging to stop automatically if the supply of air drops below a certain pressure. Notification of this is given when the AIR indicator lights up and the discharge output (DSC) turns off. This prevents objects which are not charged from being overlooked when the air supply has been stopped.

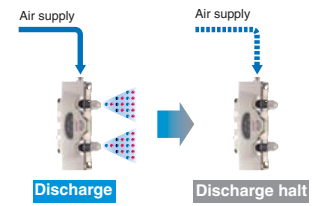

Easy connection possible

The joint kit (optional) can be used to connect up to a maximum of 5 ER-VW units. The air supply part is connected via quick connection joints, and the power supply and input/output signals can also be connected easily using connection cables with connectors at both ends.

Multiple ER-VW units can be connected to provide charge removal layouts that suit the target equipment.

Connection application example

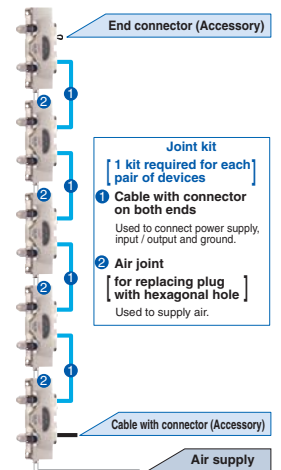
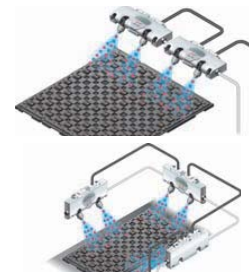

ER-VW

Functions to support accurate charge removal

In addition to the air supply monitoring function, the ER-VW is equipped with the following functions to ensure accurate charge removal.



Typical Applications

Removing charge during pickup from dicing type

Ideal for preventing damage to devices from static electricity.

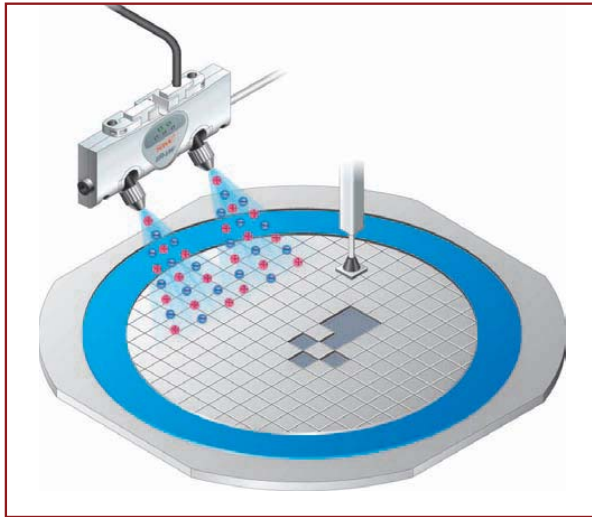

Removing charges from surfaces of CDs / DVDs

Adjustment of the nozzle angle allows the charge removal area to be laid out in accordance with the position of the object.



Technical Specifications

Type	Spot type
Model no.	ER-VW
Charge removal time ($\pm 1,000V \rightarrow \pm 100V$)	1 sec. or less (Note 1)
Ion balance	Within $\pm 15V$ (Note 1)
Supply voltage	24VDC $\pm 10\%$
Output Check (CHECK) Error (ERROR) Discharge (DSC) (Note 2)	NPN open-collector transistor
Ambient temperature	0 to $+55^{\circ}C$

Notes: 1) A typical sample applied with a supply voltage of 24V, a distance of 100mm from the front surface of the air flow outlet and a pressure of 0.25MPa (measured on a sample left in the atmosphere at a relative humidity of 65% RH or less for 24 hours or more).
2) 'DSC' is the abbreviated symbol for 'DISCHARGE'.

ER-V



Ultra compact high-performance ionizer

Features

Produces excellent ion balance

The adoption of high-frequency AC method allows extremely stable ion balance to be achieved. Because the ion balance is not affected by the pressure of air supplied or by the setup distance, no troublesome adjustments are required after setup.

High performance but no controller needed

A full range of functions have been provided with full consideration given to ease of use in the workplace. No separate controller is needed.

Nozzle variations can be selected to suit the application

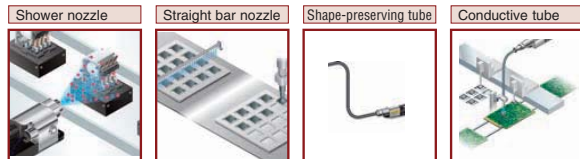

Ultra compact design accurately removes charges of objects even from narrow spaces

The main unit is merely 109×27×28mm so it can easily be combined with other devices and also be installed as an add-on. Furthermore, the high-voltage power supply is built-in so no extra space is required except for the ionizer itself.

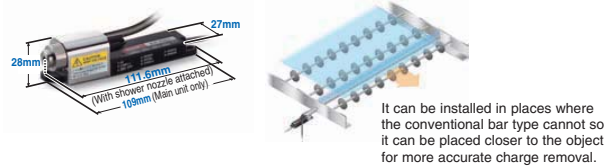

Type	Spot type
Model no.	ER-VS01
Charge removal time (±1000V → ±100V)	1 sec. or less (Note 1)
Ion balance	Within ±15V (Note 1)
Supply voltage	24VDC ±10%
Output	Check (CHECK) Error (ERROR)
	NPN open-collector transistor
Ambient temperature	0 to +55°C

Note: A typical sample applied with a supply voltage of 24V, a distance of 100mm from the front surface of the air flow outlet and a pressure of 0.25MPa while the shower nozzle is in use (measured on a sample left in the atmosphere at a relative humidity of 65% RH or less for 24 hours or more).

Typical Applications

Change removal and dust removal of lenses

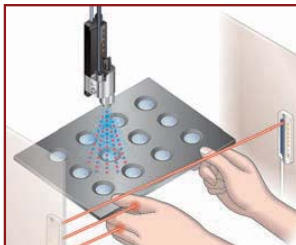

Prevent discharge damage in circuit board LEDs

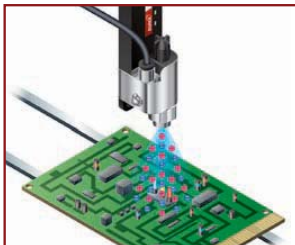

Charge removal of FPD glass surfaces

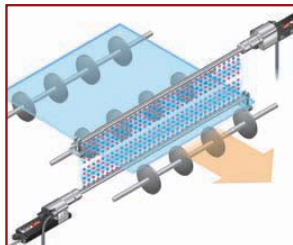

EC-G



EC-G

Pulse air-gun ionizer

Features

Direct ionized air emission

With the new pulse air-gun ionizer from SUNX, operators can comfortably neutralize static electricity while manually cleaning.

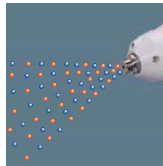

Pulsed ionized air

Instant pulse air emission with high air pressure removes dust all at once. The pulse air-gun's light-weight, ergonomic design combined with an oil- and heat-resistant 2m cable make it ideal for flexible use at the production line.



White LED illumination

A white LED on the front of the gun illuminates target objects.



Technical Specifications

Model no.	EC-G01
Charge removal time	0.5s or less ($\pm 1,000V \rightarrow \pm 100V$) (Note 1)
Applicable fluid	Air (dried clean air) (Note 2)
Supplied air flow	Max. 300l/min. (ANR) or less
Air pressure range	0.05 to 0.50MPa
Power supply voltage	Accessory AC adapter INPUT: 100 to 240VAC $\pm 10\%$ 50/60Hz (OUTPUT: 24VDC)
Power consumption	30VA or less
Discharge method	High-frequency AC method
Pulse air mode	Pulse 1 (long) / Pulse 2 (short) / CONT (continuous) selectable by switch
Weight	270g approx. (main unit only)

Notes: 1) Typical value for pulse air mode: CONT at 100mm from the front of discharge nozzle at on applied air pressure of 0.50MPa.
 2) Dried clean air is the air passing through air dryer (clearpoint $-20^{\circ}C$ approx.) and airfilter (mesh size 0.01 μm approx.)

Typical Applications

Remove dust on PCB



Remove dust on FPD



Remove dust before painting



EF-S1



Constantly checks static electricity in process lines

Features

Maintains and regulates product quality by eliminating static electric damage

The static electricity that can build up in various places in a process line can be monitored constantly so that abnormalities can be prevented before they occur. This makes it possible to determine if damage or malfunctions are being caused by static electricity so that stable product quality can be maintained.

Reduces man hours for ionizer inspections

The de-ionizing effectiveness of ionizers can be understood in real-time so that things such as ionizer damage and the replacement period for worn components can be checked objectively, reducing the number of man hours required for inspection and testing.

Sensor head

Type	Spot type
Model no.	EF-S1HS
Sensing range	8.0 to 20.5mm (51kV range) 21.0 to 40.5mm (52kV range)

Controller

Type	Spot type
Model no.	EF-S1C
Supply voltage	24VDC \pm 10%
Display range (Measurement range)	11,000 to 1000 (51kV range) 12,000 to 2000 (52kV range)
Judgment output	NPN open-collector transistor
Analog output	Output voltage 1 to 5V Output impedance 100 Ω approx.

Typical Applications

Measuring surface potential when removing BG sheets

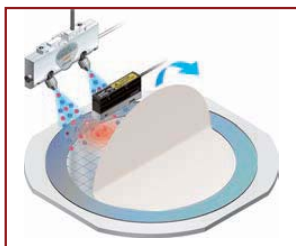

Measuring static electric charges in lead frames

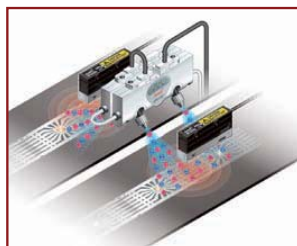

Measuring frictional electrification of LCD modules

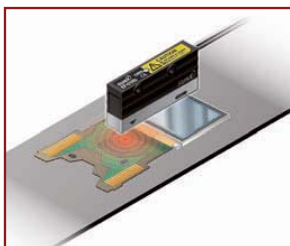

Also available: SUNX Laser markers



SUNX laser markers are ideal for non-contact, permanent labelling of most materials, e.g. plastics, glass, paper, wood and leather. Several CO₂ laser marking systems and a unique FAYb laser marker can be easily integrated into existing production systems for a great variety of labelling tasks.

Further Panasonic products

Panasonic Electric Works offers a wide product range from one source, from individual components to complete systems. Technology support for advice, design-in, installation and commissioning by our qualified application engineers round off the Panasonic service profil.



Programmable controllers

Programmable controllers from Panasonic represent "control advantages" that pay for themselves right from the start.



Servo Drives

Panasonic servo drives enable high performance motion control to be applied to almost all types of machines, including chip mounting machines and general industrial machines.



UV curing system

Aicure UJ20 is a LED curing system that quickly hardens UV-sensitive resins such as adhesives, ink and coatings. Its cutting edge LED technology is especially suited for precise, high-intensity curing.



ACD components

Components such as Eco-power meters, timers/counters, temperature controllers, limit switches and fans round off our wide Factory Automation product range.



Machine Vision Systems

Panasonic offers the complete range of high quality industrial Machine Vision Systems. From the easy Vision-Sensor to the high-end inspection machine, 100% quality inspection and process control is assured.



Human Machine Interfaces

Our compact size, bright and easy-to-read Human Machine Interfaces can be used to visualize inspection results. Touch panels can even replace the standard keypad if you so desire.

Global Network

North America

Europe

Asia Pacific

China

Japan

Panasonic Electric Works

Please contact our Global Sales Companies in:

Europe		
▶ Headquarters	Panasonic Electric Works Europe AG	Rudolf-Diesel-Ring 2, 83607 Holzkirchen, Tel. +49 (0) 8024 648-0, Fax +49 (0) 8024 648-111, www.panasonic-electric-works.com
▶ Austria	Panasonic Electric Works Austria GmbH	Josef Madersperger Str. 2, 2362 Biedermannsdorf, Tel. +43 (0) 2236-26846, Fax +43 (0) 2236-46133 www.panasonic-electric-works.at
	PEW Electronic Materials Europe GmbH	Ennshafenstraße 30, 4470 Enns, Tel. +43 (0) 7223 883, Fax +43 (0) 7223 88333, www.panasonic-electronic-materials.com
▶ Benelux	Panasonic Electric Works Sales Western Europe B.V.	De Rijn 4, (Postbus 211), 5684 PJ Best, (5680 AE Best), Netherlands, Tel. +31 (0) 499 372727, Fax +31 (0) 499 372185, www.panasonic-electric-works.nl
▶ Czech Republic	Panasonic Electric Works Czech s.r.o.	Průmyslová 1, 34815 Planá, Tel. (+420)-374 799 990, Fax (+420)-374 799 999, www.panasonic-electric-works.cz
▶ France	Panasonic Electric Works Sales Western Europe B.V.	Succursale française, 10, rue des petits ruisseaux, 91370 Verrières Le Buisson, Tél. +33 (0) 1 6013 5757, Fax +33 (0) 1 6013 5758, www.panasonic-electric-works.fr
▶ Germany	Panasonic Electric Works Europe AG	Rudolf-Diesel-Ring 2, 83607 Holzkirchen, Tel. +49 (0) 8024 648-0, Fax +49 (0) 8024 648-111, www.panasonic-electric-works.de
▶ Hungary	Panasonic Electric Works Europe AG	Erdőalja út 91/a, 1037 Budapest, Tel. +36 (0) 20 9715688, www.panasonic-electric-works.hu
▶ Ireland	Panasonic Electric Works UK Ltd.	Dublin, Tel. +353 (0) 14600969, Fax +353 (0) 14601131, www.panasonic-electric-works.co.uk
▶ Italy	Panasonic Electric Works Italia srl	Via del Commercio 3-5 (Z.I. Ferlina), 37012 Bussolengo (VR), Tel. +39 (0) 456752711, Fax +39 (0) 456700444, www.panasonic-electric-works.it
▶ Nordic Countries	Panasonic Electric Works Nordic AB	Sjöängsvägen 10, 19272 Sollentuna, Sweden, Tel. +46 859476680, Fax +46 859476690, www.panasonic-electric-works.se
▶ Poland	Panasonic Electric Works Polska sp. z o.o.	Jungmansgatan 12, 21119 Malmö, Tel. +46 40 697 7000, Fax +46 40 697 7099, www.panasonic-fire-security.com
▶ Portugal	Panasonic Electric Works España S.A.	Al. Krakowska 4/6, 02-284 Warszawa, Tel. +48 (0) 22 338-11-33, Fax +48 (0) 22 338-12-00, www.panasonic-electric-works.pl
▶ Spain	Panasonic Electric Works España S.A.	Portuguese Branch Office, Avda Adelino Amaro da Costa 728 R/C J, 2750-277 Cascais, Tel. +351 214812520, Fax +351 214812529
▶ Switzerland	Panasonic Electric Works Schweiz AG	Barajas Park, San Severo 20, 28042 Madrid, Tel. +34 913293875, Fax +34 913292976, www.panasonic-electric-works.es
▶ United Kingdom	Panasonic Electric Works UK Ltd.	Grundstrasse 8, 6343 Rotkreuz, Tel. +41 (0) 41 7997050, Fax +41 (0) 41 7997055, www.panasonic-electric-works.ch
		Sunrise Parkway, Linford Wood, Milton Keynes, MK14 6LF, Tel. +44 (0) 1908 231555, Fax +44 (0) 1908 231599, www.panasonic-electric-works.co.uk
North & South America		
▶ USA	PEW Corporation of America	629 Central Avenue, New Providence, N.J. 07974, Tel. 1-908-464-3550, Fax 1-908-464-8513, www.pewa.panasonic.com
Asia Pacific/China/Japan		
▶ China	Panasonic Electric Works (China) Co., Ltd.	Level 2, Tower W3, The Towers Oriental Plaza, No. 2, East Chang An Ave., Dong Cheng District, Beijing 100738, Tel. (010) 5925-5988, Fax (010) 5925-5973
▶ Hong Kong	Panasonic Electric Works (Hong Kong) Co., Ltd.	RM1205-9, 12/F, Tower 2, The Gateway, 25 Canton Road, Tsimshatsui, Kowloon, Hong Kong, Tel. (0852) 2956-3118, Fax (0852) 2956-0398
▶ Japan	Panasonic Electric Works Co., Ltd.	1048 Kadoma, Kadoma-shi, Osaka 571-8686, Japan, Tel. (06) 6908-1050, Fax (06) 6908-5781, http://panasonic-electric-works.net
▶ Singapore	Panasonic Electric Works Asia Pacific Pte. Ltd.	101 Thomson Road, #25-03/05, United Square, Singapore 307591, Tel. (06255) 5473, Fax (06253) 5689

Panasonic[®]

Copyright © 2010 • Printed in Germany
3174 euen 06/10