

ARUSH SWITCHGEARS

1801, 2nd Floor Bhagirath Palace, Delhi
9312211087/9811514724
enquiry@arushswitchgears.com
www.arushswitchgears.com

Numerous Brands
One Supplier

ARUSH



At *Arush Switchgears*, it is our always our constant endeavour to help our esteemed customers get the best on most competitive market prices.

Our strong alliance with the broad-list of brands helps us to always offer an extensive range of items, new product introductions from latest technologies as soon as they are available in the market. There are new products that are introduced on regular basis, from over a ocean of brands.

We'd really appreciate if you can share your product requirements for following brands & categories to get the best quotes from us.

Our Range

Automation & Control Gears	Lighting
Batteries	Pneumatics
Cables & Wires	Power Supplies
Connectors	Relays
Displays & Optoelectronics	ESD Control & Clean Room
Electricals	Sockets & Circuit Breakers
Enclosure & Storage	Switches
Fuses	Test & Measurement
HVAC, Fan & Thermal Management	Tools

Our Top Brands





CATALOG SENSORS FOR PROCESS APPLICATIONS

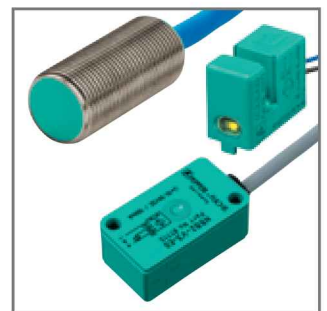
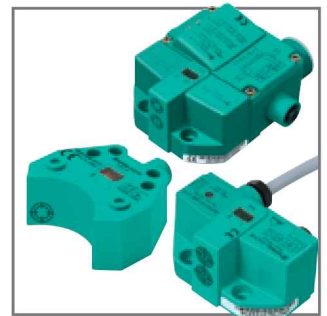



Pepperl+Fuchs – Unbeatable for quality and choice

We are a leading manufacturer of industrial sensors and sensor systems making us specialists in these fields; therefore providing you with an extensive product selection and specific solutions to fit all of your needs

SENSING YOUR NEEDS

The core area of expertise of the Factory Automation division is non-contact sensing, which is an essential requirement for efficient production processes. We offer one of the largest ranges of industrial sensors in the world, providing comprehensive coverage for a very wide range of applications. Products in the area of identification and fieldbus technology complete our offering for any kind of factory automation process.

PROTECTING YOUR PROCESS

Today, the Process Automation division of the Pepperl+Fuchs Group is the undisputed market leader in all three World markets – America, Europe and Asia – when it comes to components for intrinsic safe explosion protection.

As a worldwide leading manufacturer of industrial sensor technology and sensor systems, we are a specialist in the field of Factory Automation with an extensive range of products. The individual products can be tailored to specific application requirements on request.

Our products, which have certification in accordance with ISO 9001, meet the highest quality standards so that they can be used reliably for their intended purpose.

Our sales offices located in all major markets around the world make us right partner for the global players of Factory Automation. Through our competent contact persons we are able to provide a first-class service around the world. Our local employees have the necessary in-depth product and application knowledge to help you find the solution that best suits your needs.

Target markets:

- Machine and plant engineering
- Automotive Industry
- Mobile Equipment
- Renewable Energies
- Material Handling
- Print, Paper and Finishing
- Packaging Industry
- Process Equipment
- Doors, Gates and Elevators



Asia Pacific
Singapore



North and Central Amerika
Twinsburg, Ohio, USA

Germany

Committed to engineering excellence, our worldwide headquarters is located in Mannheim, Germany. More than 600 specialists are dedicated to continuing our heritage of high quality and innovation.



Sensors for valve actuators and valve position sensors**from page 11**

Valve position sensors are used for monitoring fittings and actuators.

These sensors from Pepperl+Fuchs combine two devices in one housing as “dual sensors” and therefore reduce mounting and maintenance costs considerably.

Pepperl+Fuchs has a wide product range of sensors and actuators approved for hazardous areas. Solutions for classic enclosure installation are available as are sensors for direct mount on the actuator.

Inductive standard sensors**from page 24**

In choosing Pepperl+Fuchs inductive sensors, you are opting for quality and performance! As a pioneer, Pepperl+Fuchs has produced inductive sensors for industrial use since 1958. Worldwide, our products have proven themselves millions of times over in automation technology.

The combinations of designs (cylindrical, rectangular, slot, ring-type) and electrical features are virtually inexhaustible.

Inductive position measurement systems**from page 36**

Pinpoint position detection plays a central role in many industrial processes. Depending on the application in question, the process may involve determining the position of linear moving units or detecting angles of valves, valve actuators, and flaps. For all these applications, Pepperl+Fuchs offers suitable non-contact operating sensors and sensor systems for industrial use.

Capacitive sensors/Magnetic field sensors**from page 38**

In addition to metallic objects, capacitive sensors detect a great variety of other materials. These are used in direct monitoring of flow and fill levels.

Our range of magnetic field sensors includes models for detecting magnets in standard applications as well as a non-contact solution for position detection of pistons in steel cylinders. You can find the required magnets for use in our magnetic field sensors in our large accessories range.

Photoelectric sensors**from page 42**

Detection, acquisition, counting, signaling, classifying, and monitoring. These processes are predominantly performed by non-contact operating photoelectric sensors, even if the distances to be bridged are somewhat large.

Pepperl+Fuchs offers one of the largest ranges of photoelectric sensors under the VISOLUX trademark. We have the right sensor for your automation application.

Rotary encoders**from page 50**

Rotary encoders are used where physical values, such as rotational speed, speed, acceleration, and direction, are to be detected. Pepperl+Fuchs offers a complete line of incremental and absolute rotary encoders, including those for use in ignition protection classes of flameproof enclosure and intrinsic safety in hazardous areas.

AS-Interface**from page 54**

Pepperl+Fuchs offers a wide range of AS-Interface modules for use in the process field.

The modules offer various options for diagnosis and communicates the status of the bus and inputs and outputs via their built-in LEDs.

Interface technology**from page 58**

Interface modules from Pepperl+Fuchs guarantee safe, reliable, and efficient signal transfer between field devices and control level. The product range extends from intrinsically safe isolated switch amplifiers to HART communication modules and Zener barriers for DIN rail installation and motherboard solutions to signal processing for all areas of application. Fieldbus solutions for decentralized connection of sensors and actuators are also part of the Pepperl+Fuchs portfolio. The product portfolio is rounded off by a variety of power supplies and a large range of accessories.

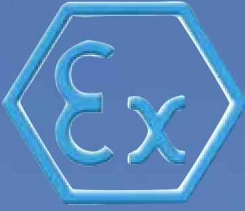

Sensors are essential to meet the various requirements of automated production in hazardous areas.

We provide reliable products for applications such as variable area flow measuring, position feedback signals on valve positioners or recording limit values on position actuators.

In addition you will find the right solution for your application in our broad range of products.



Sensors for Process Applications

<u>Contents</u>	<u>page</u>
Pepperl+Fuchs, worldwide _____	2
Overview: sensors, systems, and interfaces for hazardous areas _____	3
ATEX explosion protection _____	6
ATEX marking and meaning for electrical equipment _____	8
Inductive sensors for process applications _____	10
Position feedback for valve actuators _____	11
Sensors for box installation _____	11
Accessories for series -F25 dual sensors _____	16
Direct mount sensors _____	17
Pucks for series -F31/-F31K dual sensors _____	23
Inductive sensors, standard versions _____	24
Inductive slot type sensors _____	25
Cylindrical standard sensors _____	26
Rectangular standard sensors _____	33
Inductive ring sensors _____	35
Inductive position measurement systems _____	36
Capacitive sensors / Magnetic field sensors _____	38
Photoelectric sensors _____	42
Fork type sensors _____	44
Thru-beam sensors _____	45
Retro-reflective sensors _____	46
Diffuse mode sensors _____	47
Safety light curtains _____	48
Elevator light grid _____	48
Rotary encoders _____	50
Incremental rotary encoders _____	52
Absolute rotary encoders _____	53
AS-Interface _____	54
Interface technology for mounting rails _____	58
Switch amplifiers _____	60
Speed monitors, frequency converters, solenoid drivers _____	61
Valve couplers for FOUNDATION FIELDBUS and PROFIBUS PA _____	62
Intrinsic safe inductive sensors for 2:1 technology _____	63
Accessories _____	64
Chemical resistance _____	70
Alphabetical type list _____	71

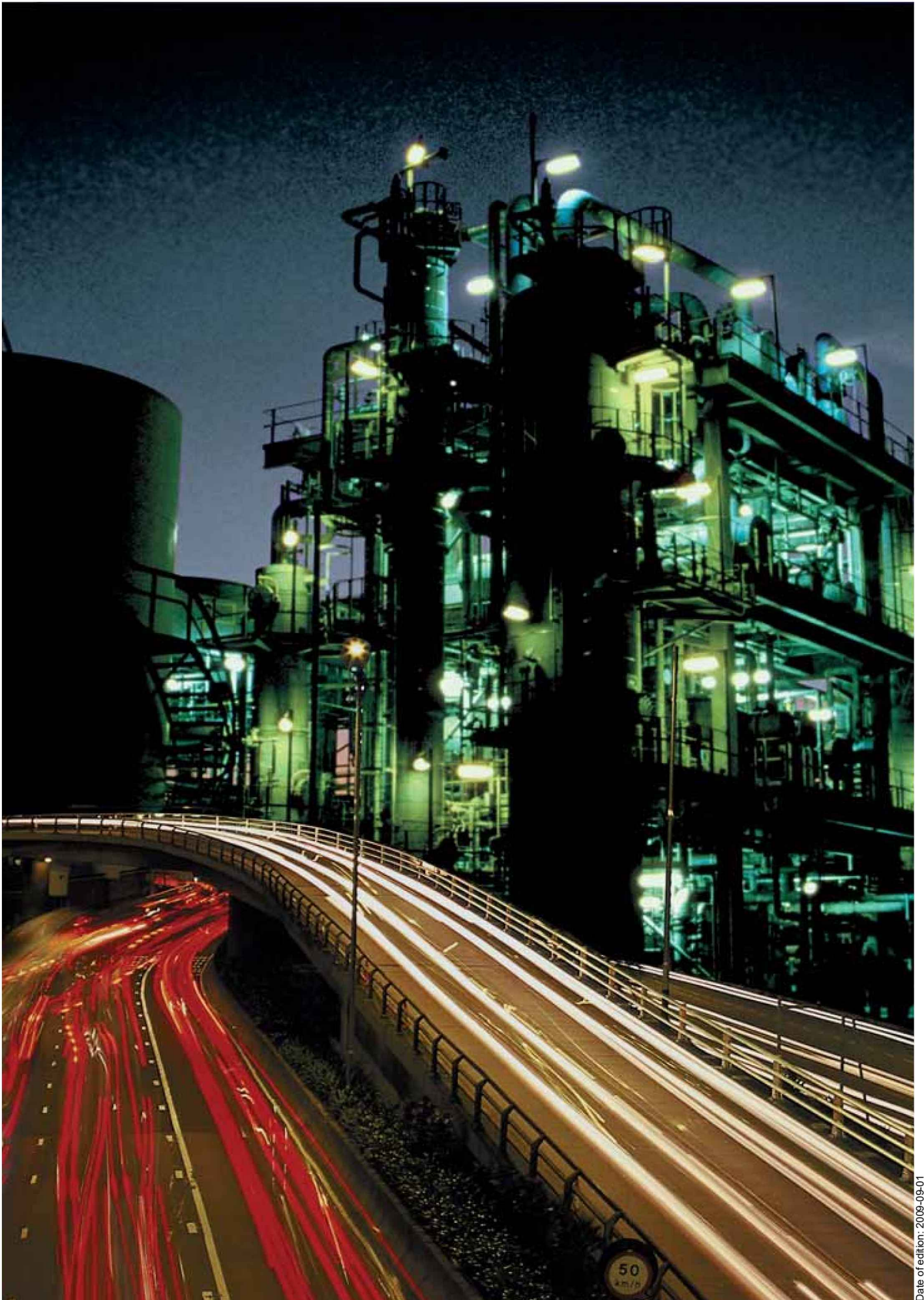

Date of edition: 2009-09-01

Basic considerations concerning ATEX and explosion protection

The fundamental concept of explosion protection not only concerns the safety of a corresponding piece of apparatus, but concerns a multitude of measures, above all organizational.

The following list shows an extract of corresponding European standards which concern the topic of mounting, installation, operation, and testing of systems in hazardous areas:

- EN 1127-1: Basic concepts and methodology of explosion protection
- EN 60079-10 / 61241-10: Zoning of gas hazardous atmospheres/dust hazardous areas
- EN 60079-14 / EN 61241-14: Guidelines for installation of electrical systems in gas hazardous areas/dust hazardous areas
- EN 60079-17: Testing and maintenance in gas and dust hazardous areas
- EN 60079-19: Repair and overhaul

In addition, relevant national laws and regulations for hazardous areas are to be observed.

Pepperl+Fuchs employees regularly conduct seminars and training on the topic of explosion protection.

Also available is the Pepperl+Fuchs "Explosion protection through intrinsic safety" manual, containing over 200 pages of information. Here, important topics concerning explosion protection are thoroughly discussed.

This and other documents on explosion protection are available for download as PDF files from our website:

<http://www.pepperl-fuchs.com>

First select your home country at the cover page. In the headline on your native page select the link "Branches + Applications" and on the next page click "Process Equipment".

The image shows a sequence of three screenshots from the Pepperl+Fuchs website. The first screenshot shows the 'Markets+Applications' menu with a red circle around the 'Markets+Applications' link. A red arrow points to the second screenshot, which shows the 'Markets+Applications' page with a red circle around the 'Process Equipment' link. Another red arrow points to the third screenshot, which shows the 'Process Equipment' page with a red circle around the 'Product Information' link.

Physikalisch-Technische Bundesanstalt
Braunschweig und Berlin

PTB



(1) Mitteilung über die Anerkennung der Qualitätssicherung Produktion

- (2) Geräte oder Schutzsysteme oder Komponenten zur bestimmungsgemäßen Verwendung in explosionsgefährdeten Bereichen - Richtlinie 94/9/EG 
- (3) Mitteilungsnummer: **PTB 97 ATEX Q008**
- (4) Produktgruppe(n): Elektronische Bausteine, Stromversorgungsgeräte, Sensoren jeweils in der bestimmenden Zündschutzart „Eigensicherheit“ Stromversorgungsgeräte in den bestimmenden Zündschutzarten „Eigensicherheit“ und „Vergußkapselung“ Sicherheitseinrichtungen in der bestimmenden Zündschutzart „Überdruckkapselung“
- Die benannte Stelle führt eine Liste der EG-Baumusterprüfbescheinigungen, für die diese Mitteilung gilt.
- (5) Antragsteller: Pepperl + Fuchs GmbH
Königsberger Allee 87, D-68307 Mannheim
- (6) Hersteller: Pepperl + Fuchs GmbH
Königsberger Allee 87, D-68307 Mannheim
- (7) Die Physikalisch-Technische Bundesanstalt (PTB), benannte Stelle Nr. 0102 für Anhang IV nach Artikel 9 der Richtlinie des Rates der Europäischen Gemeinschaften 94/9/EG vom 23. März 1994, teilt dem Antragsteller mit, daß der Hersteller ein Qualitätssicherungssystem für die Produktion unterhält, das dem Anhang IV dieser Richtlinie genügt.
- (8) Diese Mitteilung basiert auf dem vertraulichen Auditbericht Nr. 97/342/06, ausgestellt am 24.07.1997. Die Mitteilung ist gültig bis 23.07.2000 und kann zurückgezogen werden, wenn der Hersteller die Anforderungen des Anhangs VII nicht mehr erfüllt.
- Die Ergebnisse des Überwachungsaudits des Qualitätssicherungssystems Produktion sind Bestandteil dieser Mitteilung.**
- (9) Gemäß Artikel 10 (1) der Richtlinie 94/9/EG ist hinter der CE-Kennzeichnung die Kennnummer 0102 der PTB als der benannten Stelle anzugeben, die in der Produktionsüberwachungsphase tätig wird.

Zertifizierungsstelle Explosionschutz
Im Auftrag
Dr.-Ing. U. Johannsmiedler
Oberregierungsrat



Braunschweig, 24.07.1997

Seite 1/1

Mitteilungen ohne Unterschrift und ohne Siegel haben keine Gültigkeit.
Diese Mitteilung darf nur unverändert weiterverbreitet werden.
Auszüge oder Änderungen bedürfen der Genehmigung der Physikalisch-Technischen Bundesanstalt.

Approvals of Pepperl+Fuchs products for hazardous areas

You can find the ATEX approvals of our products for hazardous areas in the product overviews from Page 12.

In addition, Pepperl+Fuchs products have additional international approvals for hazardous areas, e.g. IEC-Ex, FM, NEPSI, GHOST, CCOE.

Condition for an Explosion: Ignitable source + oxygen + combustible material

Ignition source:

- Hot surfaces
- Flames and hot gases
- Mechanically generated sparks
- Electrical equipment
- Equalizing currents
- static electricity
- Lightning stroke, ultrasound

Oxygen:

- Air (21 % oxygen)
- Pure oxygen
- Compounds yielding oxygen (e. g. potassium permanganate)

Combustible material:

"Gases and dust that originate from combustible liquids and solids and are present in the right ignitable concentration"

Additional Marking According to RL 94/9/EC (ATEX 95)

Marking According to EN 60079-0

Tested According to ATEX Directive 94/9/EC

Group I includes equipment approved for mines susceptible to firedamp.

Group II covers the areas "above ground" such as chemical industry, petrochemical industry, mills (dust) etc. For the "intrinsic safety" and pressure-resistant encapsulation" type of protection, another differentiation is made between device group IIA to IIC due to protection criteria and the different ignition powers of the different gases.



II 1G

Ex

Area of Application

Equipment certified according to ATEX95 Directive is provided with an additional marking which describes the installation location (or in the case of associated electrical equipment, explains where the signal cable may lead).

First the device group is indicated, then the category and finally the atmosphere (gas and/or dust). The following categorization applies to device group II:

**Category 1
Very high safety level**

Sufficient safety due to 2 safety measures / in the case of 2 errors.

Use in zone
0 20

Atmosphere
G D

**Category 2
High safety level**

Sufficient safety in the case of frequent device faults / 1 fault.

Use in zone
1 21

Atmosphere
G D

**Category 3
Normal safety level**

Sufficient safety in case of fault free operation.

Use in zone
2 22

Atmosphere
G D*

* not conducting dust (G = gas, D = dust)

Explosion Protection

[Ex ia]

Meanings of the Brackets

Associated electrical equipment is installed in the safe area. Signal cables lead into the Ex area

Electrical equipment is divided into temperature classes according to its maximum surface temperatures. The gases are classified according to the different ignition temperatures.

Highest surface temperature of the equipment

- T1: 450 °C
- T2: 300 °C
- T3: 200 °C
- T4: 135 °C
- T5: 100 °C
- T6: 85 °C

Temperature Classes

Zone Classification

Areas in which a hazardous, explosive atmosphere may occur are divided into zones according to the probability of occurrence of these hazardous atmospheres. In case of gas atmospheres, a classification is made into zones 0, 1 and 2. In case of dust atmospheres, a classification is made into zones 20, 21 and 22.

Zone		Definition
Gas	Dust	
0	20	Present continuously or for long periods of time
1	21	Likely to exist under normal operations
2	22	Not likely under normal conditions, if so, only for short periods

CENELEC Marking	Typical Gas	Ignition power μJ
I	Methane	280
II A	Propane	> 180
II B	Ethylene	60 ... 180
II C	Hydrogen	< 60

Gerätegruppen

ia

II C





T6

For Areas at Risk from Gas Explosions

nA	Non-sparking electrical equipment (circulating machines, fuses, lights, measuring instruments and equipment with low power)
nL	Equipment and circuits with limited power

Type of Protection "n", Selection

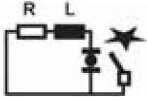
Protection type, Selection for Areas at Risk from Gas Explosions

Protection type	Gen. requirements	Flameproof	Increased safety	Intrinsic safety	Encapsulation	Protection type "n"
Symbol						
Designation		EX d	EX e	EX i	EX m	EX n
Principle of protection		Explosion is contained	Avoidance of sparks and temperatures	Power limit of sparks and temperatures	Ex-atmosphere is kept away from ignition source	Various principles of protection for zone 2
Use in zone		1 or 2	1 or 2	0, 1 or 2 *	1 or 2	2
CENELEC	EN 60079-0	EN 60079-1	EN 60079-7	EN 60079-11 / EN 60079-25	EN 60079-18	EN 60079-15
Application	All applications	Switchgear, controls, motors, command and signaling devices, power electronics	Distribution and connecting boxes, housings, motors, lights, terminals	Measurement and control technology, sensors, actuators, instrumentation	Coils of relays and motors, electronic equipment, solenoid valves, connection systems	All applications for zone 2

* ia = use in zone 0, 1 and 2, ib = use in zone 1 and 2, ic = use in zone 2

Protection type, Selection for Areas at Risk from Dust Explosions

Ex II 1D Ex iaD 20 T108 °C

Protection type intrinsic safety ia for dust

Use in zone 20

Maximum surface temperature 108 °C

Ex II 3D Ex tD A22 IP67 T80 °C

Protection type: protection by housing

Use in zone 22 according to method A (EN 61241-1)

IP protection degree for dust tightness

Maximum surface temperature 80 °C

Inductive sensors for process applications

NAMUR interface

NAMUR* proximity sensors historically have a constant characteristic.

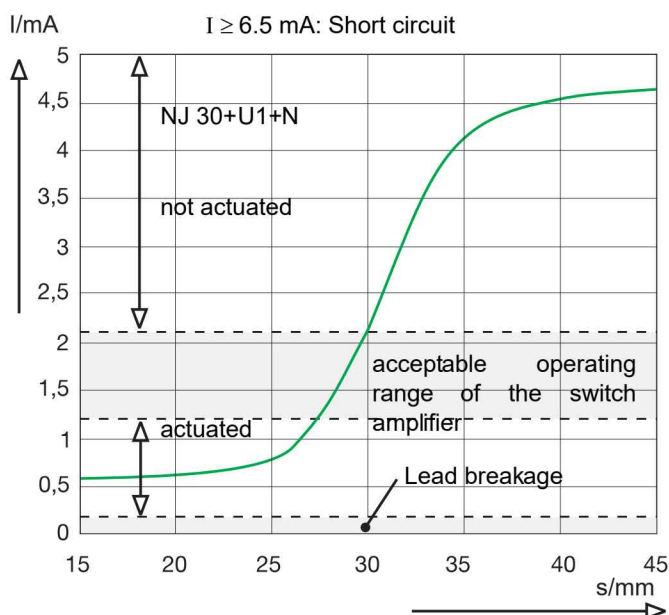

Through the use of modern technology, while retaining standard voltage and current, binary switching behavior can now be achieved in the proximity sensor (simultaneous switch status change at the sensor and amplifier).

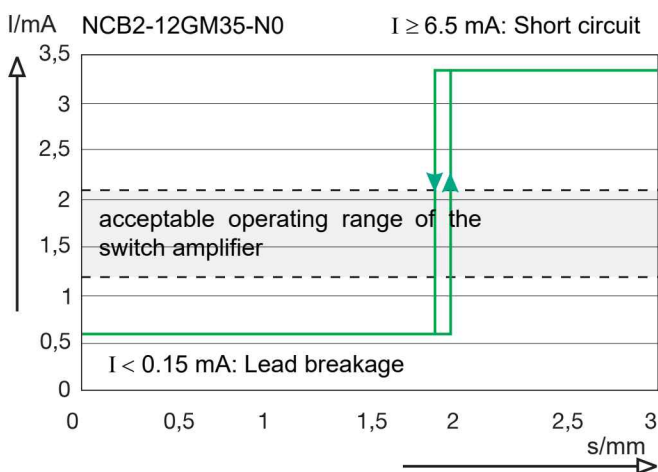

*NAMUR: Normenarbeitsgemeinschaft für Mess- und Regelungs-technik der chemischen Industrie [Standardization commission for measuring and control technology in the German chemical industry].

The advantage of the binary switching behavior of NAMUR N0 sensors is that the on/off switching status on the LED is more clearly visible (no dim effect).

Intrinsic safety

The values of current and voltage are kept so low that the NAMUR* proximity sensor can be used in hazardous areas (intrinsic safety ignition protection class). An N at the end of the designation, sometimes combined with a number, identifies this product family.

The power limitation takes place in the associated apparatus. This means that the circuit which includes a NAMUR proximity sensor is also intrinsically safe if it is supplied by a corresponding switch amplifier. The conformity of the electric values of proximity sensors and switch amplifiers is supported via a Certificate of Intrinsic Safety. As the cable inductance and capacity comprise energy storage, they are also included in this certificate.

You can find more information about explosion protection and intrinsic safety in our Explosion Protection manual.

Sensors with safety function

In principle, these proximity sensors correspond to the N types, but with a special characteristic: In the event of a sensor malfunction, the control unit, or the common connection cable, the output of the control unit automatically switches to the safe "off" state.

A series of sensors are evaluated according to IEC 61508, so that the corresponding data of failure characteristics and failure rates are available. In the SIL column of the product list, you can find information on the SIL for each sensor in the circuit.

You can find more information on the topic of Functional Safety in the **Safety Integrity Level SIL** handbook from Pepperl+Fuchs. This and other documents are available for download at <http://www.pepperl-fuchs.com> (see page 7, below).

Sensors that are suitable and approved for SIL3 are identified with the marking SN or S1N at the end of the designation. The safety function is only guaranteed with corresponding control units.

You can find a selection of these interface and control units from Pepperl+Fuchs on page 60 and the complete overview at <http://www.pepperl-fuchs.com>. Enter ***-SH-*** in the "Product/Key word search" field and click SEARCH. The first 5 results are displayed. To display all results, click on "Show more results".

The note in the data sheets, "for NF metals only," for types with contact function indicates that this model only functions with non-ferrous metals (e.g. aluminum/brass).

2:1 technology: two intrinsically safe signals via one line



In many applications there are two intrinsically safe, binary signals at one measuring point. In conventional circuit technology, every measuring point in a hazardous area is assigned a switch amplifier in a non-hazardous area.

The signal transfer is then provided via 2 isolated NAMUR circuits.

With 2:1 technology, Pepperl+Fuchs offers you the opportunity to transmit two intrinsically safe signals via one cable, cutting wiring costs by 50%. Wiring is via conventional wiring technology. The evaluation of both signals takes place in a single switch amplifier, providing for additional savings in costs and installation space in the control cabinet.

You can find more information about 2:1 technology on Page 59.

Sensors for box installation

The “box solution” concept means the integration of sensors in an accessories box, which also provides mechanical coupling of sensors to actuators of various dimensions.



This solution developed so that the sensors are not directly exposed to ambient conditions and allows conventional standard sensors to be used.

The majority of reputable drive manufacturers offer standard boxes equipped with Pepperl+Fuchs sensors, optionally with or without visual display.

Features:

- **Versatile** – the box offers individual interface options
- **Reliable** – the installation is integrated in the box and protected against manipulation and contamination
- **Safe** – the box complies with accident prevention regulations
- **Simple** – as mounting takes place via preset sensors
- **Standardized** – the connection marking of MSR devices corresponds to DIN 45140 T.1 and the mechanical mounting of VDI/VDE 3845

Standard sensors

Pepperl+Fuchs offers both cylindrical standard sensors with short lengths up to 40 mm as well as slot sensors with 3.5 mm slot widths and series V3 sensors for box installation. These are rectangular sensors in standard dimensions of mechanical microswitches. As output stages, standard DC-versions can be used, as can NAMUR versions with an increased temperature range (from -50 °C to +100 °C).

cylindrical



slot-type

V3 series



Position sensors for box installation

With the F25 sensor series, Pepperl+Fuchs offers you an effective alternative for position monitoring of valve actuators.



They combine two devices in one enclosure as “dual sensors” and therefore reduce installation and maintenance costs considerably. Decades of experience has provided Pepperl+Fuchs with a wide product range of sensors and actuators. Sensors of the F25 series are suitable for both the box solution as well as for direct mount on the actuator.

Features:

- **dual sensor** – the sensor has 2 active zones
- **Safe** – fingers cannot be inserted between the actuator and the sensor and therefore complies with accident prevention regulations
- **Variable** – mounting is directly on the drive or fitting via a console or in the box
- **Simple** – mounting is adjustment free and without additional settings
- **Practical** – more than two switching points are stackable if required

Board solution for box installation

For this type of mounting, the box simultaneously serves as a terminal compartment for the sensor and valve connection.

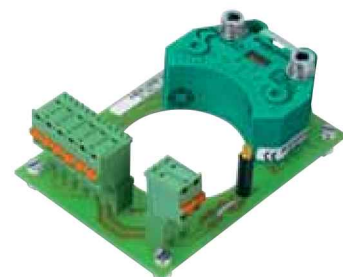

Encoded, removable screw terminals and cage clamp terminals are available.

LEDs on the dual sensor enable you to check the switching state. The LED on the board enables status check of the valve.

Versions with shielded connection (only NAMUR) and with 2 valve controllers are available.

Features:

- **Plug & Play** – due to the encoded, removable terminal block, expansion of the drive together with accessories requires no qualified specialists
- **Inexpensive** – the connection option for the drive control valve saves an additional terminal box or plug
- **Simple** – fault location is facilitated due to the LED status display
- **Safe connection** – encoded terminal blocks prevent misconnection
- **Safe operation** – it is adjustment free and completely factory checked

1.1

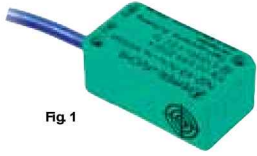

Fig. 1



Fig. 2

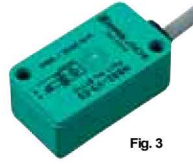

Fig. 3



- Protection degree IP67
- 2 mm embeddable
NJ2-... / NCB2-... / NBB2-...
- 3 mm embeddable
NBB3-...
- 4 mm not embeddable
NBN4-... NCN4-...

Slot type sensors and cylindrical sensors for box installation you will find starting from page 24

Inductive Sensors, for box installation

	Switching element function	Rated operating distance	Installation	2:1-Technology *)	Ambient Temperature	Connection Type	Ex-identification	Figure	SIL, acc. to IEC 61508	Wiring diagram
2 Wire, NAMUR										
NJ2-V3-N	NAMUR N.C.	2 mm	embeddable	●	-25 ... 100 °C	130 mm, PVC cable	II 1G Ex ia IIC T6 II 1D Ex iaD 20 T 108 °C	1	2	
NJ2-V3-N-V5	NAMUR N.C.	2 mm	embeddable	●	-25 ... 100 °C	Faston 4.8 mm	II 1G Ex ia IIC T6 II 1D Ex iaD 20 T 108 °C	2	2	
NCB2-V3-N0	NAMUR N.C.	2 mm	embeddable		-25 ... 100 °C	130 mm, PVC cable	II 1G Ex ia IIC T6 II 1D Ex iaD 20 T 108 °C	1	2	
NCB2-V3-N0-V5	NAMUR N.C.	2 mm	embeddable		-25 ... 100 °C	Faston 4.8 mm	II 1G Ex ia IIC T6 II 1D Ex iaD 20 T 108 °C	2	2	
NCN4-V3-N0	NAMUR N.C.	4 mm	not embeddable		-25 ... 100 °C	130 mm, PVC cable	II 1G Ex ia IIC T6 II 1D Ex iaD 20 T 108 °C	1	2	
NCN4-V3-N0-V5	NAMUR N.C.	4 mm	not embeddable		-25 ... 100 °C	Faston 4.8 mm	II 1G Ex ia IIC T6 II 1D Ex iaD 20 T 108 °C	2	2	
2 Wire, DC										
NBB3-V3-Z4	N.O.	3 mm	embeddable		-25 ... 85 °C	130 mm, PVC cable		3	-	
NBB3-V3-Z4-V5	N.O.	3 mm	embeddable		-25 ... 70 °C	Faston 4.8 mm		2	-	
3 Wire, DC										
NBB2-V3-E2-3G-3D	PNP N.O.	2 mm	embeddable		-25 ... 70 °C	130 mm, PVC cable	II 3G Ex nA IIC T6 X II 3D Ex tD A22 IP67 T80°C X	3	-	
NBN4-V3-E2-3G-3D	PNP N.O.	4 mm	not embeddable		-25 ... 70 °C	130 mm, PVC cable	II 3G Ex nA IIC T6 X II 3D Ex tD A22 IP67 T80°C X	3	-	
NBB2-V3-E2	PNP N.O.	2 mm	embeddable		-25 ... 70 °C	130 mm, PVC cable		3	-	
NBB2-V3-E2-V5	PNP N.O.	2 mm	embeddable		-25 ... 70 °C	Faston 4.8 mm		2	-	
NBN4-V3-E2	PNP N.O.	4 mm	not embeddable		-25 ... 70 °C	130 mm, PVC cable		3	-	
NBB2-V3-E3-3G-3D	PNP N.C.	4 mm	embeddable		-25 ... 70 °C	130 mm, PVC cable	II 3G Ex nA IIC T6 X II 3D Ex tD A22 IP67 T80°C X	3	-	
2 Wire, AC/DC										
NBB2-V3-US	N.O.	2 mm	embeddable		-25 ... 70 °C	2 m, PVC cable		3	-	

*) Information on 2:1 technology from Pepperl+Fuchs you will find at page 59

Slot type sensors and cylindrical sensors for box installation you will find starting from page 24

For complete data and product description, see data sheet on www.pepperl-fuchs.com

Date of edition: 2009-08-27



Fig. 1



Fig. 2



- Rated operating distance 3 mm
- Protection degree IP67
- Embeddable mountable

	Switching element function	2:1-Technology ^{*)}	Ambient Temperature	Connection Type	Protection degree	Ex-Identification	SIL, acc. to IEC 61508	Figure	Wiring diagram
2 Wire, NAMUR									
NCN3-F25-N4-K	NAMUR Dual N.C.		-25 ... 100 °C	MINI-COMBICON	IP20	II 2G Ex ia IIC T6		2	
NCN3-F25-N4-0,14	NAMUR Dual N.C.	●	-25 ... 100 °C	180 mm, PVC cable	IP67	II 1G Ex ia IIC T6 II 3G Ex nL IIC T6 X II 3G Ex ic IIC T6 X II 3D Ex tD A22 IP67 T80°C X		1	
NCN3-F25-SN4-0,14	NAMUR Dual N.C.		-25 ... 100 °C	180 mm, PVC cable	IP67	II 1G Ex ia IIC T6 II 3G Ex ic IIC T6 X	3 ^{**)}	1	
2 Wire, DC									
NBN3-F25-Z8-0,14	Dual N.O.		-25 ... 70 °C	180 mm, PVC cable	IP67			1	
3 Wire, DC									
NBN3-F25-E8-K	PNP, Dual N.O.		-25 ... 70 °C	MINI-COMBICON	IP20			2	
NBN3-F25-E8-0,14	PNP, Dual N.O.		-25 ... 70 °C	180 mm, PVC cable	IP67			1	

^{*)} Information on 2:1 technology from Pepperl+Fuchs you will find at page 59

^{**)} The SIL3 functionality can only be achieved if this safety sensor is operated with an actuator BT32XS or BT32XAS and a suitable Pepperl+Fuchs switch amplifier, e.g. KFD2-SH-EX1.



Matching with the series -F25 dual sensors we provide with various actuators which differ in height and hole diameter for the installation on different drive shafts.

To match the mounting hole configurations of different valve positioners we provide with suitable installation kits which consist of an actuator and if needed a mounting plate.

You will find these accessory parts at page 16.



Fig 1

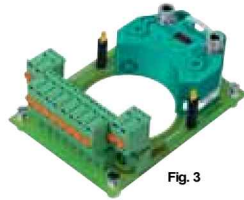

Fig 3

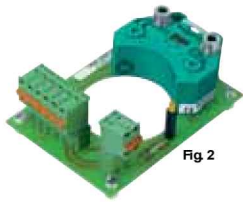

Fig 2



- Rated operating distance 3 mm
- Embeddable mountable
- PL2... without valve connection
- PL3... with valve and screen connection
- PL4... with 2 valve connections
- Simplified connection for 2:1-Technology
PL...-F25-N5-...

2:1-Technology

	Switching element function	2:1-Technology *)	Ambient Temperature	Connection Type	Valve Connection	Ex-Identification	SIL, acc. to IEC 61508	Figure	Wiring diagram
2 Wire, NAMUR									
PL2-F25-N4-K	NAMUR Dual N.C.	●	-25 ... 100 °C	Cage clamp terminals	-	II 1G Ex ia IIC T6 II 3G Ex nL IIC T6 X	1		
PL2-F25-N4-S	NAMUR Dual N.C.	●	-25 ... 100 °C	screw terminals	-	II 1G Ex ia IIC T6	1		
PL2-F25-SN4-K	NAMUR Dual N.C.	●	-25 ... 100 °C	Cage clamp terminals	-	II 1G Ex ia IIC T6 II 3G Ex ic IIC T6 X	3**) 1		
PL2-F25-N5-K	NAMUR Dual N.C.	●	-25 ... 100 °C	Cage clamp terminals	-	II 1G Ex ia IIC T6	1		
PL2-F25-N5-S	NAMUR Dual N.C.	●	-25 ... 100 °C	screw terminals	-	II 1G Ex ia IIC T6	1		
PL3-F25-N4-K	NAMUR Dual N.C.	●	-25 ... 100 °C	Cage clamp terminals	●	II 1G Ex ia IIC T6 II 3G Ex nL IIC T6 X	2		
PL3-F25-N4-S	NAMUR Dual N.C.	●	-25 ... 100 °C	screw terminals	●	II 1G Ex ia IIC T6	2		
PL3-F25-SN4-K	NAMUR Dual N.C.	●	-25 ... 100 °C	Cage clamp terminals	●	II 1G Ex ia IIC T6 II 3G Ex ic IIC T6 X	3**) 2		
PL3-F25-N5-K	NAMUR Dual N.C.	●	-25 ... 100 °C	Cage clamp terminals	●	II 1G Ex ia IIC T6	2		
PL3-F25-N5-S	NAMUR Dual N.C.	●	-25 ... 100 °C	screw terminals	●	II 1G Ex ia IIC T6	2		
PL4-F25-N4-K	NAMUR Dual N.C.	●	-25 ... 100 °C	Cage clamp terminals	●	II 1G Ex ia IIC T6 II 3G Ex nL IIC T6 X	3		
PL4-F25-N4-S	NAMUR Dual N.C.	●	-25 ... 100 °C	screw terminals	●	II 1G Ex ia IIC T6	3		

*) Information on 2:1 technology from Pepperl+Fuchs you will find at page 59

**) The SIL3 functionality can only be achieved if this safety sensor is operated with an actuator BT32XS or BT32XAS and a suitable Pepperl+Fuchs switch amplifier, e.g. KFD2-SH-EX1.

Suitable actuators, installation kits and mounting plates you will find at page 16.

For complete data and product description, see data sheet on www.pepperl-fuchs.com



Fig 1

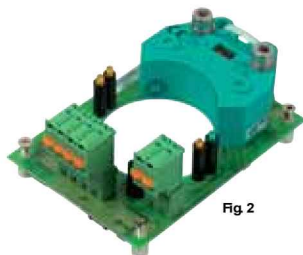

Fig 2



- Rated operating distance 3 mm
- Embeddable mountable
- PL1... with valve connection
- PL2... without valve connection

	Switching element function	Ambient Temperature	Connection Type	Valve Connection	Figure	Wiring diagram
3 Wire, DC						
PL1-F25-E8-K	PNP Dual N.O.	-25 ... 70 °C	Cage clamp terminals	●	2	
PL1-F25-E8-S	PNP Dual N.O.	-25 ... 70 °C	screw terminals	●	2	
PL2-F25-E8-K	PNP Dual N.O.	-25 ... 70 °C	Cage clamp terminals	-	1	
PL2-F25-E8-S	PNP Dual N.O.	-25 ... 70 °C	screw terminals	-	1	
AS-Interface						
PL1-F25-B3B-K	AS-Interface	-25 ... 70 °C	Cage clamp terminals	●	2	
PL1-F25-B3B-S	AS-Interface	-25 ... 70 °C	screw terminals	●	2	

Suitable actuators, installation kits and mounting plates you will find at page 16.

Pucks, Installation Kits and Mounting Plates for Series -F25 Dual Sensors

1.1

Inductive Sensors, for box installation

Installation kit ¹⁾	Shaft diameter ²⁾	Shaft height	Mounting hole configuration	consisting of:		Fig.
				Puck	Plate	
BT32-F25-0	< 34 mm	20 mm	30 x 80 mm	BT32	–	1
BT33-F25-0	< 34 mm	30 mm	30 x 80 mm	BT33	–	3
BT34-F25-2	preferably > 34 mm	20/30 mm	30 x 80 mm	BT34	K2	2
BT34-F25-3	preferably > 34 mm	30 mm	30 x 130 mm	BT34	K3	4
BT34-F25-4	preferably > 34 mm	50 mm	30 x 130 mm	BT34	K4	5
MH5-F25-Y43089	< 34 mm	20/30 mm	30 x 130 mm	–	Metal plate	6
MH20-F25-Y43090	Height compensation for additionally mounted controller			–	F25 fully encapsulated	7

1) Fixing screws for the dual senso in scope of delivery

2) If the ring height is > 3 mm then the snap ring height is the determinator, not the shaft diameter.

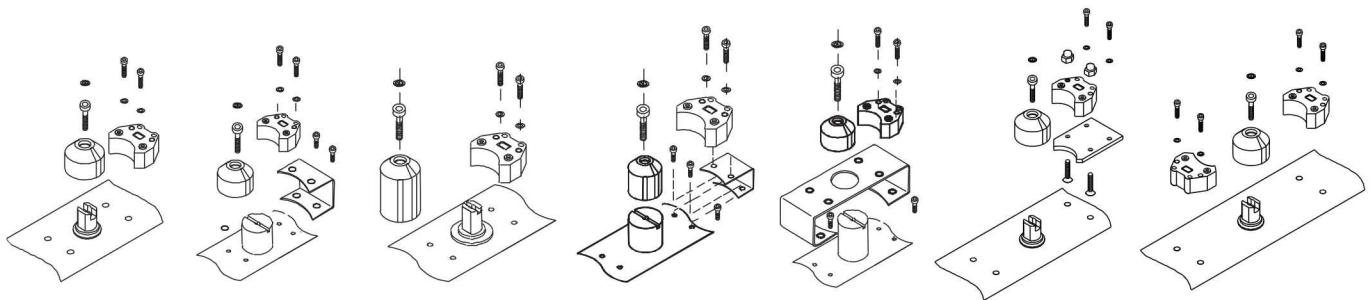

Part	Shaft diameter	Shaft height	Number of actuators	Notes	Fig.
Puck ³⁾					
BT32	≤ 34 mm	20 mm	2	Height of active surface: 28 mm	8
BT32XS	≤ 34 mm	20 mm	1	as BT32, but reversed direction of action	9
BT32XAS	≤ 34 mm	20 mm	2	as BT32, but reversed direction of action	9
BT33	≤ 34 mm	30 mm	2	Height of active surface: 38 mm	10
BT34	≥ 34 mm	≥ 20 mm	2	Height of active surface: 28 mm, sitting on the shaft	11
BT37	≥ 34 mm	20 mm	1	Puck BT37 with 4 mm groove for regulator attachment	–
Mounting Plate					
K2	–	–	–	Mounting hole configuration 30 x 80 mm	2
K3	–	–	–	Mounting hole configuration 30 x 130 mm	4
K4	–	–	–	Mounting hole configuration 30 x 130 mm	5

3) Puck without fixing screws for the dual sensor

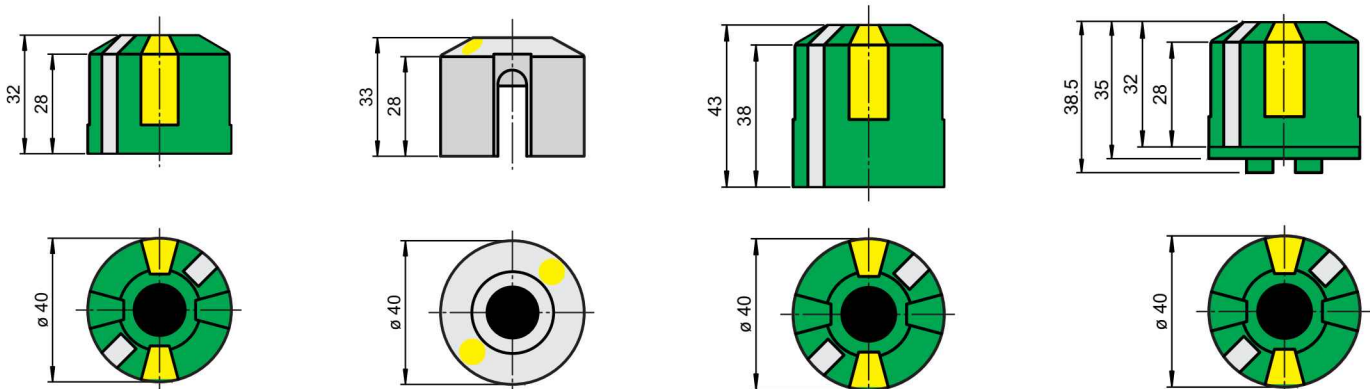

Fig. 8

Fig. 9

Fig. 10

Fig. 11

Date of edition: 2009-08-24

Direct mount sensors

Are you looking for a solution for position feedback that enables direct, stable, and durable mounting of the sensor and actuator?

Series F31 and F31K from Pepperl+Fuchs are best suited for direct mounting on drives with no additional mounting fittings required. You can request the position of all normal drives irrespective of size and make with just two actuators.

Series F31K offers a terminal compartment with cage clamp technology or screw terminals for system and valve connection.

Versions with one, two, and without valve connections are available. The valve controller can be directly connected via the sensor connection if required. This reduces mounting time and wiring costs.

With series F25 sensors, Pepperl+Fuchs also offers an interesting solution for position feedback of manually operated ball valves and butterfly valves.

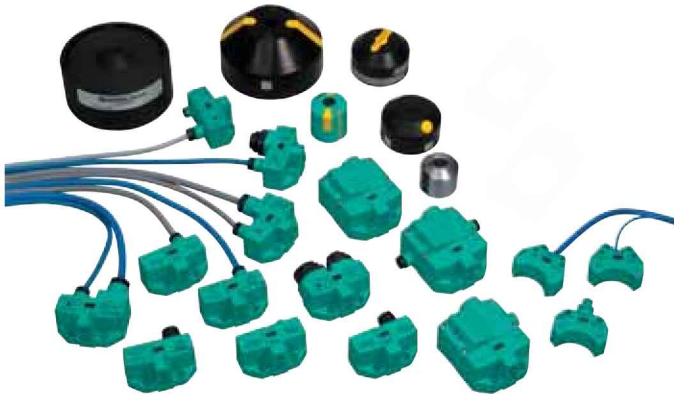

Features:

- **Safe** - the dimensions of the sensor as well as the distances between the sensor and actuator are selected such that the system involves no risk of injury during operation (which is TÜV certified)
- **Variable** - the sensors are suitable for all normal drives irrespective of size and make
- **Fixed** - because of the round mounting holes in the sensor enclosure, the alignment is retained after a sensor is changed.
- **Universal** - clockwise and counterclockwise drives can be scanned
- **Unambiguous** - the assignment of the actuator to the hole pattern of the drive is clear and the actuator position is plainly visible
- **Diverse** - you can choose between cable connection, plug connection (V1, V16, or V18), and terminal compartment connection
- **Transparent** - the switching states, supply voltage, and valve controller are clearly indicated via LEDs



- Rated operating distance: 3 mm
- Protection degree IP67
- Direct mounting on standard actuators
- Embeddable mountable

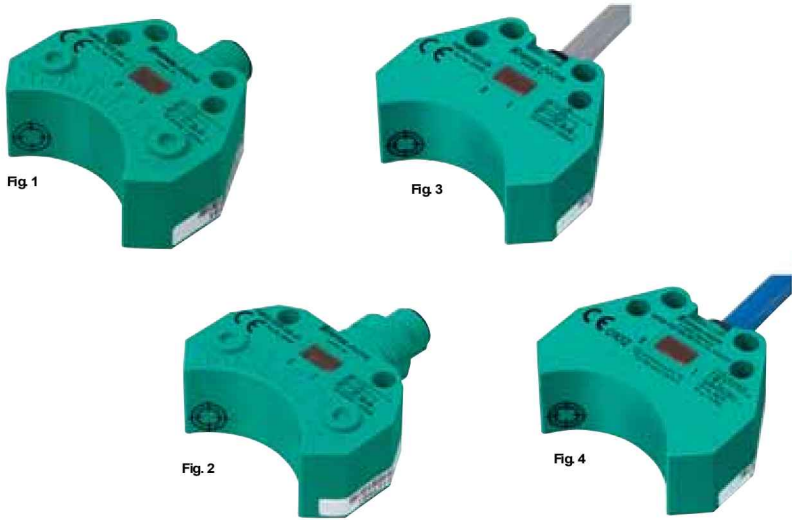

Switching element function	2:1-Technology *)	Connection Type	Ambient Temperature	Ex-Identification	SIL, acc. to IEC 61508	Figure	Wiring diagram
----------------------------	-------------------	-----------------	---------------------	-------------------	------------------------	--------	----------------

2 Wire, NAMUR								
NCN3-F25-N4-V1	NAMUR Dual N.C.	●	Connector M12 x 1, 4 pin	-25 ... 100 °C	ⓧ II 1G Ex ia IIC T6 ⓧ II 3G Ex nL IIC T6 X ⓧ II 3G Ex ic IIC T6 X ⓧ II 3D Ex tD A22 IP67 T80°C X	1		
NCN3-F25-N4-5M	NAMUR Dual N.C.	●	5 m, PVC cable	-25 ... 100 °C	ⓧ II 1G Ex ia IIC T6 ⓧ II 3G Ex nL IIC T6 X ⓧ II 3G Ex ic IIC T6 X ⓧ II 3D Ex tD A22 IP67 T80°C X	4		
NCN3-F25F-N4-V1	NAMUR Dual N.C.	●	Connector M12 x 1, 4 pin	-25 ... 100 °C	ⓧ II 1G Ex ia IIC T6 ⓧ II 3G Ex nL IIC T6 X ⓧ II 3G Ex ic IIC T6 X ⓧ II 3D Ex tD A22 IP67 T80°C X	2		
NCN3-F25-SN4-5M	NAMUR Dual N.C.		5 m, PVC cable	-25 ... 100 °C	ⓧ II 1G Ex ia IIC T6 ⓧ II 3G Ex ic IIC T6 X	3**)		4
NCN3-F25-SN4-V1	NAMUR Dual N.C.		Connector M12 x 1, 4 pin	-25 ... 100 °C	ⓧ II 1G Ex ia IIC T6 ⓧ II 3G Ex ic IIC T6 X	3**)		1

2 Wire, DC							
NBN3-F25-Z8-5M	Dual N.O.		5 m, PVC cable	-25 ... 70 °C		3	
NBN3-F25-Z8-V1	Dual N.O.		V1-Connector	-25 ... 70 °C		1	

3 Wire, DC							
NBN3-F25-E8-5M	PNP Dual N.O.		5 m, PVC cable	-25 ... 70 °C		3	
NBN3-F25-E8-V1	PNP Dual N.O.		V1-Connector	-25 ... 70 °C		1	
NBN3-F25F-E8-V1	PNP Dual N.O.		V1-Connector	-25 ... 70 °C		2	
NBN3-F25-E8-3G-3D-5M	PNP Dual N.O.		5 m, PVC cable	-25 ... 70 °C	ⓧ II 3G Ex nA IIC T6 X ⓧ II 3D Ex tD A22 IP67 T80°C X	3	
NBN3-F25-E8-V1-3G-3D	PNP Dual N.O.		V1-Connector	-25 ... 70 °C	ⓧ II 3G Ex nA IIC T6 X ⓧ II 3D Ex tD A22 IP67 T80°C X	1	
NBN3-F25F-E8-V1-3G-3D	PNP Dual N.O.		V1-Connector	-25 ... 70 °C	ⓧ II 3G Ex nA IIC T6 X ⓧ II 3D Ex tD A22 IP67 T80°C X	2	

*) Information on 2:1 technology from Pepperl+Fuchs you will find at page 59

**) The SIL3 functionality can only be achieved if this safety sensor is operated with an actuator BT32XS or BT32XAS and a suitable Pepperl+Fuchs switch amplifier, e.g. KFD2-SH-EX1.

Suitable actuators, installation kits and mounting plates you will find at page 16.

For complete data and product description, see data sheet on www.pepperl-fuchs.com

Date of edition: 2009-08-27

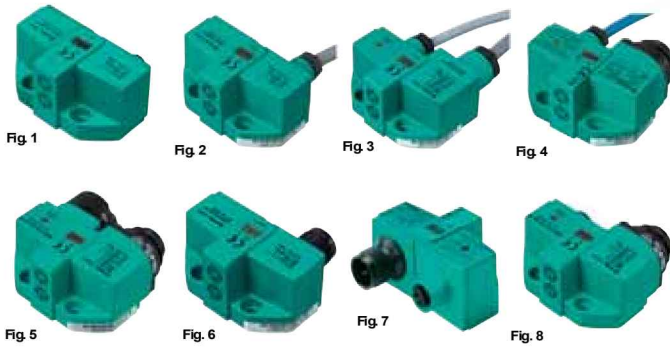

- 3 mm Rated operating distance
- Embeddable mountable
- Protection degree IP67
- Direct mounting on standard actuators
- Compact and stable housing
- Simplified connection for 2:1-technology
NCN3-F31-N5-V18-V1

	Switching element function	2:1-Technology *)	Ambient Temperature	Connection (system side)	Connection (valve side)	Ex-identification	Figure	Wiring diagram
2 Wire, NAMUR								
NCN3-F31-N4-V1	NAMUR Dual N.C.	●	-25 ... 100 °C	Connector M12 x 1, 4 pin		Ex II 1G Ex ia IIC T6 Ex II 3G Ex ic IIC T6 X	1	
NCN3-F31-N4-K	NAMUR Dual N.C.	●	-25 ... 100 °C	5 m PVC cable		Ex II 1G Ex ia IIC T6 Ex II 3G Ex ic IIC T6 X	2	
NCN3-F31-N4-V18	NAMUR Dual N.C.	●	-25 ... 100 °C	Connector M18 x 1, 4 pin		Ex II 1G Ex ia IIC T6 Ex II 3G Ex ic IIC T6 X	6	
NCN3-F31-N4-K-K	NAMUR Dual N.C.	●	-25 ... 100 °C	5 m PVC cable	0.5 m PVC cable	Ex II 1G Ex ia IIC T6 Ex II 3G Ex ic IIC T6 X	3	
NCN3-F31-N4-V16-K	NAMUR Dual N.C.	●	-25 ... 100 °C	Connector Rd24 x 1/8", 7 pin	0.5 m PVC cable	Ex II 1G Ex ia IIC T6 Ex II 3G Ex ic IIC T6 X	4	
NCN3-F31-N4-V16-V16	NAMUR Dual N.C.	●	-25 ... 100 °C	Connector Rd24 x 1/8", 7 pin	Connector Rd24 x 1/8", 7 pin	Ex II 1G Ex ia IIC T6 Ex II 3G Ex ic IIC T6 X	5	
NCN3-F31-N4-V16-V1	NAMUR Dual N.C.	●	-25 ... 100 °C	Connector Rd24 x 1/8", 7 pin	Connector M12 x 1, 4 pin	Ex II 1G Ex ia IIC T6 Ex II 3G Ex ic IIC T6 X	8	
NCN3-F31-N5-V18-V1	NAMUR Dual N.C.	●	-25 ... 100 °C	Connector M18 x 1, 4 pin	Connector M12 x 1, 4 pin	Ex II 1G Ex ia IIC T6	7	
2 Wire, DC								
NBN3-F31-Z8-V1	Dual N.O.		-25 ... 70 °C	Connector M12 x 1, 4 pin			1	
NBN3-F31-Z8-V1-3G-3D	Dual N.O.		-25 ... 70 °C	Connector M12 x 1, 4 pin		Ex II 3G Ex nA IIC T6 X Ex II 3D Ex tDA22 IP67 T80°C X	1	
NBN3-F31-Z8-K	Dual N.O.		-25 ... 70 °C	5 m PVC cable			2	
NBN3-F31-Z8-K-3G-3D	Dual N.O.		-25 ... 70 °C	5 m PVC cable		Ex II 3G Ex nA IIC T6 X Ex II 3D Ex tDA22 IP67 T80°C X	2	
NBN3-F31-Z8-V18	Dual N.O.		-25 ... 70 °C	Connector M18 x 1, 4 pin			6	
NBN3-F31-Z8-K-K	Dual N.O.		-25 ... 70 °C	5 m PVC cable	0.5 m PVC cable		3	
NBN3-F31-Z8-V16-V16	Dual N.O.		-25 ... 70 °C	Connector Rd24 x 1/8", 7 pin	Connector Rd24 x 1/8", 7 pin		5	
NBN3-F31-Z8-V16-V15	Dual N.O.		-25 ... 70 °C	Connector Rd24 x 1/8", 7 pin	Connector M12 x 1, 5 pin		8	
2 Wire, AC/DC								
NBN3-F31-U8-K	Dual N.O.		-25 ... 70 °C	5 m PVC cable			2	
NBN3-F31-U8-V18	Dual N.O.		-25 ... 70 °C	Connector M18 x 1, 4 pin			6	
NBN3-F31-U8-V125	Dual N.O.		-25 ... 70 °C	Connector 1/2"-20, 3 pin			1	

*) Information on 2:1 technology from Pepperl+Fuchs you will find at page 59

For complete data and product description, see data sheet on www.pepperl-fuchs.com

Date of edition: 2009-09-01

1.2

Inductive Sensors, position feedback for open construction

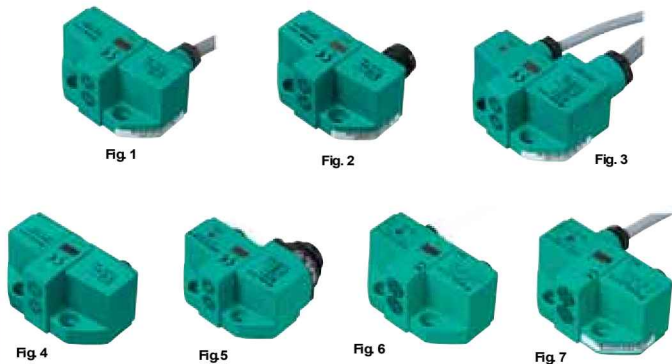

- 3 mm Rated operating distance
- Ambient Temperature -25 °C ... 70 °C
- Embeddable mountable
- Protection degree IP67
- Direct mounting on standard actuators
- Compact and stable housing
- A/B slave with extended addressing possibility for up to 62 slaves
NCN3-F31-B3B-...

1.2

Inductive Sensors, position feedback for open construction

	Switching element function	Connection (system side)	Connection (valve side)	Ex-identification	Figure	Wiring diagram
3 Wire, DC						
NBN3-F31-E8-K	PNP Dual N.O.	5 m PVC cable	-		1	
NBN3-F31-E8-K-3G-3D	PNP Dual N.O.	5 m PVC cable	-	Ⓢ II 3G Ex nA IIC T6 X Ⓢ II 3D Ex tD A22 IP67 T80°C X	1	
NBN3-F31-E8-V1	PNP Dual N.O.	Connector M12 x 1, 4 pin	-		4	
NBN3-F31-E8-V1-3G-3D	PNP Dual N.O.	Connector M12 x 1, 4 pin	-	Ⓢ II 3G Ex nA IIC T6 X Ⓢ II 3D Ex tD A22 IP67 T80°C X	4	
NBN3-F31-E8-V18	PNP Dual N.O.	Connector M18 x 1, 4 pin	-		2	
NBN3-F31-E8-V18-3G-3D	PNP Dual N.O.	Connector M18 x 1, 4 pin	-	Ⓢ II 3G Ex nA IIC T6 X Ⓢ II 3D Ex tD A22 IP67 T80°C X	2	
NBN3-F31-E8-K-K	PNP Dual N.O.	5 m PVC cable	0.5 m PVC cable		3	
NBN3-F31-E8-K-K-3G-3D	PNP Dual N.O.	5 m PVC cable	0.5 m PVC cable	Ⓢ II 3G Ex nA IIC T6 X Ⓢ II 3D Ex tD A22 IP67 T80°C X	3	
NBN3-F31-E8-V16-V15	DC Dual N.O.	Connector Rd 24 x 1/8, 7 pin	Connector M12 x 1, 5 pin		5	
AS-Interface ¹⁾						
NCN3-F31-B3B-V1	programmable	Connector M12 x 1, 4 pin	-		4	
NCN3-F31-B3B-V1-V1	programmable	Connector M12 x 1, 4 pin	Connector M12 x 1, 4 pin		6	
NCN3-F31-B3B-V1-K	programmable	Connector M12 x 1, 4 pin	0.5 m PVC cable		7	
NCN3-F31-B3B-V1-K-3G-3D	programmable	Connector M12 x 1, 4 pin	0.5 m PVC cable	Ⓢ II 3G Ex nA IIC T6 X Ⓢ II 3D Ex tD A22 IP67 T80°C X	7	

¹⁾ Connection with FAZ-T1-FK-V1R

For complete data and product description, see data sheet on www.pepperl-fuchs.com

Date of edition: 2009-08-27



Fig. 1



Fig. 3



Fig. 2



Fig. 4

- 3 mm Rated operating distance
- Embeddable mountable
- Protection degree IP67
- Direct mounting on standard actuators
- Compact and stable housing



	Switching element function	2:1-Technology ^{*)}	Ambient Temperature	Connection (system side)	Connection (valve side)	Ex-Identification	Figure	Wiring diagram
2 Wire, NAMUR								
NCN3-F31K-N4	NAMUR Dual N.C.	●	-25 ... 100 °C	Cage clamp terminals	-	II 1G Ex ia IIC T6 II 3G Ex ic IIC T6 X	1	
NCN3-F31K-N4-S	NAMUR Dual N.C.		-25 ... 100 °C	screw terminals	-	II 1G Ex ia IIC T6	1	
NCN3-F31K-N4-K	NAMUR Dual N.C.	●	-25 ... 100 °C	Cage clamp terminals	Cage clamp terminals	II 1G Ex ia IIC T6 II 3G Ex ic IIC T6 X	2	
NCN3-F31K-N4-K-S	NAMUR Dual N.C.		-25 ... 100 °C	screw terminals	screw terminals	II 1G Ex ia IIC T6 II 3G Ex ic IIC T6 X	2	
NCN3-F31K-N4-V1-V1	NAMUR Dual N.C.	●	-25 ... 100 °C	Cage clamp terminals	2 x Connector M12 x 1, 4 pin	II 1G Ex ia IIC T6 II 3G Ex ic IIC T6 X	3	
2 Wire, DC								
NBN3-F31K-Z8	DC Dual N.O.		-25 ... 70 °C	Cage clamp terminals	-		1	
NBN3-F31K-Z8-3G-3D	DC Dual N.O.		-25 ... 70 °C	Cage clamp terminals	-	II 3G Ex nA IIC T6 X II 3D Ex tD A22 IP67 T80°C X	1	
NBN3-F31K-Z8-K	DC Dual N.O.		-25 ... 70 °C	Cage clamp terminals	Cage clamp terminals		2	
NBN3-F31K-Z8-B13-3G-3D	DC Dual N.O.		-25 ... 70 °C	Cage clamp terminals	Cage clamp terminals	II 3G Ex nA IIC T6 X II 3D Ex tD A22 IP67 T80°C X	4	
NBN3-F31K-Z8-V1-V1	DC Dual N.O.		-25 ... 70 °C	Cage clamp terminals	2 x Connector M12 x 1, 4 pin		3	

^{*)} Information on 2:1 technology from Pepperl+Fuchs you will find at page 59

For complete data and product description, see data sheet on www.pepperl-fuchs.com

Date of edition: 2009-09-01

Subject to modifications without notice

Pepperl+Fuchs Group
www.pepperl-fuchs.com

USA: +1 330 486 0001
fa-info@us.pepperl-fuchs.com

Germany: +49 621 776-4411
fa-info@pepperl-fuchs.com

Copyright Pepperl+Fuchs

Singapore: +65 6779 9091
fa-info@sg.pepperl-fuchs.com



Fig. 1

Fig. 3

Fig. 5



Fig. 2



Fig. 4

- 3 mm Rated operating distance
- Embeddable mountable
- Protection degree IP67
- Direct mounting on standard actuators
- Compact and stable housing
- A/B slave with extended addressing possibility for up to 62 slaves
NCN3-F31K-B3B...



1.2

Inductive Sensors, position feedback for open construction





	Switching element function	Ambient Temperature	Connection (system side)	Connection (valve side)	Ex-identification	Figure	Wiring diagram
3 Wire, DC							
NBN3-F31K-E8	PNP Dual N.O.	-25 ... 70 °C	Cage clamp terminals	-		1	
NBN3-F31K-E8-3G-3D	PNP Dual N.O.	-25 ... 70 °C	Cage clamp terminals	-	II 3G Ex nA IIC T6 X II 3D Ex tD A22 IP67 T80°C X	1	
NBN3-F31K-E8-K	PNP Dual N.O.	-25 ... 70 °C	Cage clamp terminals	Cage clamp terminals		2	
NBN3-F31K-E8-B13-3G-3D	PNP Dual N.O.	-25 ... 70 °C	Cage clamp terminals	Cage clamp terminals	II 3G Ex nA IIC T6 X II 3D Ex tD A22 IP67 T80°C X	5	
NBN3-F31K-E8-V1-V1	PNP Dual N.O.	-25 ... 70 °C	Cage clamp terminals	2 x Connector M12 x 1, 4 pin		3	
AS-Interface							
NCN3-F31K-B3B-B31	programmable	-25 ... 70 °C	screw terminals			4	

Date of edition: 2009-09-02



For complete data and product description, see data sheet on www.pepperl-fuchs.com

Pucks for Series -F31 dual sensors with fixed switch positions

These positioning pucks are made of a conductive plastic material which prevents static charges and allows installation in potentially explosive environments. The outer surfaces of the BT65X and BT115X positioning pucks are made of stainless steel with openings as activation targets. This results in an inverted operation.

Puck	Shaft diameter	Shaft height	Mounting hole configuration	Notes	Figure
BT65A	< 58 mm	20 mm and 30 mm	30 x 80 mm	Ring diameter max. 65 mm, snap ring height max. 6 mm. Suitable for cw and ccw moving valve positioners. 90°/180° action (BT65A) or 90° action (BT65X)	
BT65X					
BT115A	< 90 mm	30 mm and 50 mm	30 x 130 mm	Ring diameter max. 110 mm, snap ring height max. 7 mm. Suitable for cw and ccw moving valve positioners. 90°/180° action (BT115A) or 90° action (BT115X)	
BT115X					

Pucks for Series F31 dual sensors with adjustable switching positions

Puck	Shaft diameter	Shaft height	Mounting hole configuration	Notes	Figure
BT65B	< 58 mm	20 mm and 30 mm*)	30 x 80 mm	Ring diameter max. 65 mm, snap ring height max. 6 mm.	
BT115B	< 90 mm	30 mm and 50 mm	30 x 130 mm	Ring diameter max. 110 mm, snap ring height max. 7 mm.	

*) 30 mm if mounting plate MH-BT65B is used

Mounting plate MH-BT65B

<p>MH-BT65B</p> <p>Adaptor plate for the use of BT65B pucks on positioners with: Mounting hole configuration 80 mm x 30 mm Mounting hole configuration 130 mm x 30 mm and shaft height 30 mm</p>	
--	---

Date of edition: 2009-09-01

Inductive sensors, standard versions

For reliable, non-contact detection of metallic objects up to a distance of 100 mm, inductive sensors are the correct technical and economic solution. As a pioneer, Pepperl+Fuchs has produced inductive sensors for industrial use since 1958.

Our inductive sensors have proven themselves in use millions of times over in automation technology. The combinations of designs and electrical features are virtually inexhaustible.

1. Slot sensors

The detection field for sensors of this design lies between the two housing sections. Metallic objects are reliably detected in this area.



Features:

- **Versatile** - slot widths from 2 mm to 30 mm are available.
- **Universal** - all metals are reliably detected without a reduction factor.

2. Standard cylindrical designs

A variety of applications requires the use of cylindrical inductive sensors with various sensing ranges and electric output types; the most varied dimensions and with tried and tested enclosure materials, such as stainless steel, in cable as well as connector version.

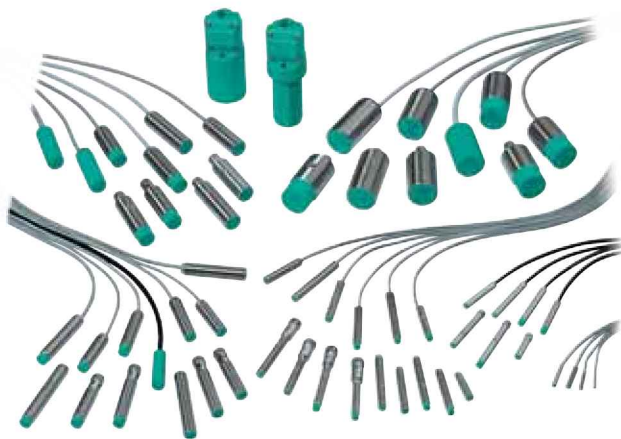

Features:

- **Versatile** - diameters from 4.5 mm to 50 mm
- **Variable** - cable as well as connector versions
- **Cost-effective** - nickel-plated brass enclosure is also available for pnp NO types
- **Powerful performance** - standard as well as increased switching distances are available for NAMUR and DC types

3. Standard rectangular designs

As with cylindrical sensors, a wide variety of enclosure versions for surface mounting are also available for rectangular sensors, optionally with cable, connector, or terminal compartment and with the greatest variety of sensing ranges.



Removable bases with terminal compartment enable simple sensor changes without disconnecting cables and the loss of settings for the *VariKont* and FP series. The *VariKont* and *VariKont L (-L2)* series with their rotating heads offer simple and extremely stable adaptation of the detection direction relevant to the requirements of the plant.

Features:

- **Versatile** - the terminal compartment versions allow connection of a wide range of cables
- **Variable** - the *VariKont* series sensor surface rotates 5 ways and the *VariKont L* series, as many as 25 ways

4. Ring sensors

For sensors of this series, the magnetic field for object detection is directed inwards toward the ring-shaped opening. Due to their design, these sensors are suitable for use in float-type detection during flow control.



Features:

- **Versatile** - diameters from 10 mm to 43 mm are available

1.3

Inductive Sensors, standard type sensors



- Slot width 2 mm ... 30 mm
 - Extended temperature range down to -50 °C and up to +100 °C
 - Protection degree IP67
 - Applicable up to SIL2 acc. to IEC 61508
 - Applicable up to SIL3 acc. to IEC 61508
- SJ2-SN
SJ2-S1N
SJ3,5-SN
SJ3,5-S1N

	Switching element function	Slot width [mm]	Depth of immersion (lateral) typ. [mm]	2:1-Technology ¹⁾	Ambient temperature	Connection type	Ex-identification	SIL, acc. to IEC 61508	Wiring diagram
2 Wire, NAMUR, N.C.									
SJ2-SN	N.C.	2	6	●	-40 ... 100 °C	Strand	II 1G Ex ia IIC T6 II 3G Ex ic IIC T6 X II 1D Ex iaD 20 T 108 °C	3 ^{**)}	
SC2-N0-GN ²⁾	N.C.	2	6		-25 ... 100 °C	Strand	II 1G Ex ia IIC T6 II 3G Ex ic IIC T6 X II 1D Ex iaD 20 T 108 °C	2	
SC2-N0-YE ²⁾	N.C.	2	6		-25 ... 100 °C	Strand	II 1G Ex ia IIC T6 II 3G Ex ic IIC T6 X II 1D Ex iaD 20 T 108 °C	2	
SJ3,5-SN	N.C.	3,5	6	●	-50 ... 100 °C	Strand	II 1G Ex ia IIC T6 II 3G Ex ic IIC T6 X II 1D Ex iaD 20 T 108 °C	3 ^{**)}	
SC3,5-G-N0	N.C.	3,5	6	●	-25 ... 100 °C	Strand	II 1G Ex ia IIC T6 II 3G Ex ic IIC T6 X II 1D Ex iaD 20 T 108 °C	2	
SC3,5-N0-BU ²⁾	N.C.	3,5	6	●	-25 ... 100 °C	Strand	II 1G Ex ia IIC T6 II 1D Ex iaD 20 T 108 °C	2	
SC3,5-N0-GN ²⁾	N.C.	3,5	6	●	-25 ... 100 °C	Strand	II 1G Ex ia IIC T6 II 1D Ex iaD 20 T 108 °C	2	
SC3,5-N0-WH ²⁾	N.C.	3,5	6	●	-25 ... 100 °C	Strand	II 1G Ex ia IIC T6 II 1D Ex iaD 20 T 108 °C	2	
SC3,5-N0-YE ²⁾	N.C.	3,5	6	●	-25 ... 100 °C	Strand	II 1G Ex ia IIC T6 II 1D Ex iaD 20 T 108 °C	2	
SJ5-N	N.C.	5	6		-25 ... 100 °C	Strand	II 1G Ex ia IIC T6 II 1D Ex iaD 20 T 108 °C	2	
SJ5-G-N	N.C.	5	6		-25 ... 100 °C	Strand	II 1G Ex ia IIC T6 II 1D Ex iaD 20 T 108 °C	2	
SJ5-K-N	N.C.	5	9		-25 ... 100 °C	PVC cable	II 1G Ex ia IIC T6 II 2G Ex ia IIC T6 II 1D Ex iaD 20 T 108 °C	2	
SJ10-N	N.C.	10	15		-25 ... 100 °C	PVC cable	II 1G Ex ia IIC T6 II 1D Ex iaD 20 T 108 °C	2	
SJ15-N	N.C.	15	17,5		-25 ... 70 °C	PVC cable	II 1G Ex ia IIC T6 II 1D Ex iaD 20 T 108 °C	2	
SJ30-N	N.C.	30	28,5		-25 ... 70 °C	PVC cable	II 1G Ex ia IIC T6 II 1D Ex iaD 20 T 108 °C	2	
2 Wire, NAMUR, N.O.									
SJ2-S1N	N.O.	2	6	●	-25 ... 100 °C	Strand	II 1G Ex ia IIC T6 II 3G Ex ic IIC T6 X II 1D Ex iaD 20 T 108 °C	3	
SJ3,5-S1N	N.O.	3,5	6	●	-25 ... 100 °C	Strand	II 1G Ex ia IIC T6 II 3G Ex ic IIC T6 X II 1D Ex iaD 20 T 108 °C	3	

^{**)} The SIL3 functionality can only be achieved if this safety sensor is operated with a suitable Pepperl+Fuchs switch amplifier, e.g. KFD2-SH-EX1.

¹⁾ Information on 2:1 technology from Pepperl+Fuchs you will find at page 59

²⁾ Depending on the value of their different switching hysteresis slotted sensors with otherwise identical characteristics are indicated by an additional marking.

- YE: switching hysteresis = 0 ... 0.05 mm
- WH: switching hysteresis = 0.06 ... 0.1 mm
- GN: switching hysteresis = 0.11 ... 0.2 mm
- BU: switching hysteresis = 0.21 ... 0.4 mm

For complete data and product description, see data sheet on www.pepperl-fuchs.com

Subject to modifications without notice

Pepperl+Fuchs Group
www.pepperl-fuchs.com

USA: +1 330 486 0001
fa-info@us.pepperl-fuchs.com

Germany: +49 621 776-4411
fa-info@pepperl-fuchs.com

Copyright Pepperl+Fuchs
Singapore: +65 6779 9091
fa-info@sg.pepperl-fuchs.com



- NAMUR interface, N.C.
 - Extended temperature range down to -40 °C and up to +100 °C
 - High protection degree, up to IP68
 - Applicable up to SIL2 acc. to IEC 61508
 - Applicable up to SIL3 acc. to IEC 61508
- NJ2-11-SN
 NJ2-11-SN-G
 NJ6-22-SN
 NJ6-22-SN-G



1.3

Inductive Sensors, standard type sensors

	Rated operating distance [mm]	2:1-Technology *)	Installation	Threaded housing	Diameter [mm]	Ambient temperature	Connection type	Protection degree	Ex-identification	SIL acc. to IEC 61508	Wiring diagram
--	--------------------------------	-------------------	--------------	------------------	---------------	---------------------	-----------------	-------------------	-------------------	-----------------------	----------------

2 Wire, NAMUR N.C.											
NJ0,8-4,5-N	0.8	●	embed-dable		4.5	-25 ... 100 °C	PVC cable	IP67	Ex II 2G Ex ia IIC T6	2	
NCB1,5-6,5M25-N0	1.5	●	embed-dable		6.5	-25 ... 100 °C	PVC cable	IP67	Ex II 2G Ex ia IIC T6	2	
NCB1,5-6,5M25-N0-V1	1.5	●	embed-dable		6.5	-25 ... 100 °C	Connector M12 x 1, 4-pol.	IP67	Ex II 2G Ex ia IIC T6	2	
NJ1,5-6,5-N	1.5	●	embed-dable		6.5	-25 ... 100 °C	PVC cable	IP67	Ex II 1G Ex ia IIC T6 Ex II 1G Ex ia IIC T6 Ex II 1D Ex iaD 20 T 108 °C	2	
NJ2-11-N	2	●	embed-dable		11	-25 ... 100 °C	PVC cable	IP68	Ex II 1G Ex ia IIC T6 Ex II 3G Ex nL IIC T6 X Ex II 3G Ex ic IIC T6 X Ex II 1D Ex iaD 20 T 108 °C Ex II 3D Ex tD A22 IP67 T80°C X	2	
NJ2-11-N-G	2		embed-dable	●	14	-25 ... 100 °C	PVC cable	IP68	Ex II 1G Ex ia IIC T6 Ex II 3G Ex nL IIC T6 X Ex II 3G Ex ic IIC T6 X Ex II 1D Ex iaD 20 T 108 °C Ex II 3D Ex tD A22 IP67 T80°C X	2	
NJ2-11-SN	2	●	embed-dable		11	-40 ... 100 °C	silicon cable	IP68	Ex II 1G Ex ia IIC T6 Ex II 1D Ex iaD 20 T 108 °C	3**)	
NJ2-11-SN-G	2	●	embed-dable	●	14	-40 ... 100 °C	silicon cable	IP68	Ex II 1G Ex ia IIC T6 Ex II 1D Ex iaD 20 T 108 °C	3**)	
NJ5-11-N	5		not embed-dable		11	-25 ... 100 °C	PVC cable	IP68	Ex II 2G Ex ia IIC T6	2	
NJ5-11-N-G	5	●	not embed-dable	●	14	-25 ... 100 °C	PVC cable	IP68	Ex II 2G Ex ia IIC T6 Ex II 1D Ex iaD 20 T 108 °C	2	
NJ6-22-N	6		embed-dable		22	-25 ... 100 °C	PVC cable	IP68	Ex II 2G Ex ia IIC T6 Ex II 3G Ex ic IIC T6 X	2	
NJ6-22-N-G	6		embed-dable	●	24	-25 ... 100 °C	PVC cable	IP68	Ex II 2G Ex ia IIC T6	2	
NJ6-22-SN	6		embed-dable		22	-40 ... 100 °C	silicon cable	IP68	Ex II 1G Ex ia IIC T6 Ex II 1D Ex iaD 20 T 108 °C	3**)	
NJ6-22-SN-G	6	●	embed-dable	●	24	-40 ... 100 °C	silicon cable	IP68	Ex II 1G Ex ia IIC T6 Ex II 1D Ex iaD 20 T 108 °C	3**)	
NJ10-22-N	10		not embed-dable		22	-25 ... 100 °C	PVC cable	IP68	Ex II 2G Ex ia IIC T6	2	
NJ10-22-N-G	10		not embed-dable	●	24	-25 ... 100 °C	PVC cable	IP68	Ex II 2G Ex ia IIC T6	2	

*) Information on 2:1 technology from Pepperl+Fuchs you will find at page 59

***) The SIL3 functionality can only be achieved if this safety sensor is operated with a suitable Pepperl+Fuchs switch amplifier, e.g. KFD2-SH-EX1.

For complete data and product description, see data sheet on www.pepperl-fuchs.com

Date of edition: 2009-09-01

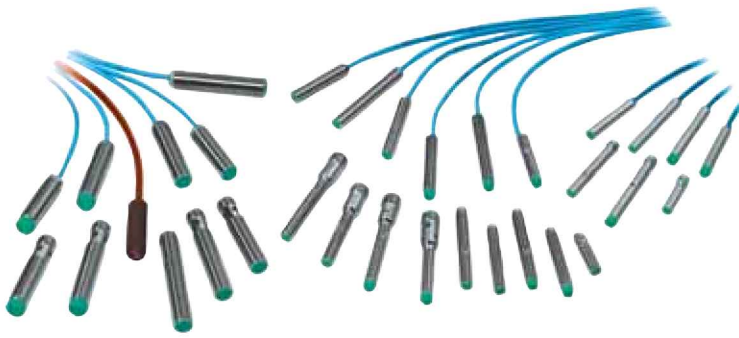

- Plastic or stainless steel housing
- NAMUR interface, N.C.
- High protection degree, up to IP68
- Best visible LED
all ...-N0 - types
- Extended temperature range down to -50 °C and up to +100 °C
- Applicable up to SIL2 acc. to IEC 61508
- Applicable up to SIL3 acc. to IEC 61508
NJ2-12GK-SN
NJ4-12GK-SN

Switching element function	Rated operating distance [mm]	2:1-Technology *)	Installation	Ambient temperature	Connection type	Protection degree	Ex-identification	SIL, acc. to IEC 61508	Wiring diagram
----------------------------	-------------------------------	-------------------	--------------	---------------------	-----------------	-------------------	-------------------	------------------------	----------------

2 Wire, NAMUR N.C.

NJ0,8-5GM-N	N.C.	0,8	●	embeddable	-25 ... 100 °C	PVC cable	IP67	Ex II 1G Ex ia IIC T6 Ex II 1D Ex iaD 20 T 108 °C	2	
NCB1,5-8GM25-N0	N.C.	1,5	●	embeddable	-25 ... 100 °C	PVC cable	IP67	Ex II 1G Ex ia IIC T6 Ex II 3G Ex ic IIC T6 X Ex II 1D Ex iaD 20 T 108 °C	2	
NCB1,5-8GM25-N0-V1	N.C.	1,5	●	embeddable	-25 ... 100 °C	Connector M12 x 1, 4 pin	IP67	Ex II 1G Ex ia IIC T6 Ex II 1D Ex iaD 20 T 108 °C	2	
NJ1,5-8GM-N	N.C.	1,5	●	embeddable	-25 ... 100 °C	PVC cable	IP67	Ex II 1G Ex ia IIC T6	2	
NJ1,5-8GM-N-V1	N.C.	1,5	●	embeddable	-25 ... 100 °C	Connector M12 x 1, 4 pin	IP67	Ex II 2G Ex ia IIC T6	2	
NJ2-12GK-N	N.C.	2	●	embeddable	-25 ... 100 °C	PVC cable	IP68	Ex II 2G Ex ia IIC T6 Ex II 1D Ex iaD 20 T 108 °C	2	
NJ4-12GK-N	N.C.	4		not embeddable	-25 ... 100 °C	PVC cable	IP68	Ex II 2G Ex ia IIC T6 Ex II 1D Ex iaD 20 T 108 °C	2	
NJ2-12GK-SN	N.C.	2	●	embeddable	-40 ... 100 °C	silicon cable	IP68	Ex II 1G Ex ia IIC T6 Ex II 1D Ex iaD 20 T 108 °C	3**)	
NJ4-12GK-SN	N.C.	4		not embeddable	-50 ... 100 °C	silicon cable	IP68	Ex II 1G Ex ia IIC T6 Ex II 3G Ex nL IIC T6 X Ex II 3G Ex ic IIC T6 X Ex II 1D Ex iaD 20 T 108 °C Ex II 3D Ex tD A22 IP67 T80°C X	3**)	
NCB2-12GK35-N0	N.C.	2		embeddable	-25 ... 100 °C	PVC cable	IP67	Ex II 2G Ex ia IIC T6 Ex II 1D Ex iaD 20 T 108 °C	2	
NCN4-12GK35-N0	N.C.	4		not embeddable	-25 ... 100 °C	PVC cable	IP67	Ex II 2G Ex ia IIC T6 Ex II 1D Ex iaD 20 T 108 °C	2	
NJ2-12GM-N	N.C.	2	●	embeddable	-25 ... 100 °C	PVC cable	IP67	Ex II 1G Ex ia IIC T6 Ex II 1D Ex iaD 20 T 108 °C	2	
NJ2-12GM-N-V1	N.C.	2	●	embeddable	-25 ... 100 °C	Connector M12 x 1, 4 pin	IP67	Ex II 1G Ex ia IIC T6	2	
NJ4-12GM-N	N.C.	4		not embeddable	-25 ... 100 °C	PVC cable	IP67	Ex II 1G Ex ia IIC T6 Ex II 1D Ex iaD 20 T 108 °C	2	
NJ4-12GM-N-V1	N.C.	4		not embeddable	-25 ... 100 °C	Connector M12 x 1, 4 pin	IP67	Ex II 1G Ex ia IIC T6	2	
NCB2-12GM35-N0	N.C.	2		embeddable	-25 ... 100 °C	PVC cable	IP67	Ex II 1G Ex ia IIC T6 Ex II 3G Ex nL IIC T6 X Ex II 3G Ex ic IIC T6 X Ex II 1D Ex iaD 20 T 108 °C Ex II 3D Ex tD A22 IP67 T80°C X	2	
NCN4-12GM35-N0	N.C.	4		not embeddable	-25 ... 100 °C	PVC cable	IP67	Ex II 1G Ex ia IIC T6 Ex II 3G Ex nL IIC T6 X Ex II 3G Ex ic IIC T6 X Ex II 1D Ex iaD 20 T 108 °C Ex II 3D Ex tD A22 IP67 T80°C X	2	
NCB2-12GM35-N0-V1	N.C.	2		embeddable	-25 ... 100 °C	Connector M12 x 1, 4 pin	IP67	Ex II 1G Ex ia IIC T6 Ex II 1D Ex iaD 20 T 108 °C	2	
NCN4-12GM35-N0-V1	N.C.	4		not embeddable	-25 ... 100 °C	Connector M12 x 1, 4 pin	IP67	Ex II 1G Ex ia IIC T6 Ex II 1D Ex iaD 20 T 108 °C	2	
NCB4-12GM40-N0	N.C.	4	●	embeddable	-25 ... 100 °C	PVC cable	IP67	Ex II 1G Ex ia IIC T6 Ex II 3G Ex ic IIC T6 X	2	
NCB4-12GM40-N0-V1	N.C.	4	●	embeddable	-25 ... 100 °C	Connector M12 x 1, 4 pin	IP67	Ex II 1G Ex ia IIC T6 Ex II 3G Ex nL IIC T6 X Ex II 3G Ex ic IIC T6 X Ex II 3D Ex tD A22 IP67 T80°C X	2	

*) Information on 2:1 technology from Pepperl+Fuchs you will find at page 59

***) The SIL3 functionality can only be achieved if this safety sensor is operated with a suitable Pepperl+Fuchs switch amplifier, e.g. KFD2-SH-EX1.

For complete data and product description, see data sheet on www.pepperl-fuchs.com

Date of edition: 2009-08-27

Subject to modifications without notice

Pepperl+Fuchs Group
www.pepperl-fuchs.com

USA: +1 330 486 0001
fa-info@us.pepperl-fuchs.com

Germany: +49 621 776-4411
fa-info@pepperl-fuchs.com

Copyright Pepperl+Fuchs

Singapore: +65 6779 9091
fa-info@sg.pepperl-fuchs.com



- Plastic or stainless steel housing
- NAMUR interface
- High protection degree, up to IP68
- Extended temperature range down to -40 °C and up to +150 °C
- Applicable up to SIL2 acc. to IEC 61508
- Applicable up to SIL3 acc. to IEC 61508
 NJ3-18GK-S1N
 NJ5-18GK-SN
 NJ8-18GK-SN
- Compression proof up to 350 bar, dynamic on active surface
 NJ1,5-18GM-N-D
 NJ1,5-18GM-N-D-V1

1.3

Inductive Sensors, standard type sensors

	Switching element function	Rated operating distance [mm]	2:1-Technology ¹⁾	Installation	Ambient temperature	Connection type	Protection degree	Ex-identification	SIL, acc. to IEC 61508	Wiring diagram
2 Wire, NAMUR										
NJ3-18GK-S1N	N.O.	3	●	embeddable	-25 ... 100 °C	silicon cable	IP68	Ex II 1G Ex ia IIC T6 Ex II 3G Ex ic IIC T6 X Ex II 1D Ex iaD 20 T 108 °C	3**	
NJ3-18GK-S1N-130	N.O.	3		embeddable	-25 ... 130 °C	silicon cable	IP68		3**	
NJ1,5-18GM-N-D	N.C.	1.5		embeddable	-25 ... 85 °C	PVC cable	IP68	Ex II 2G Ex ia IIC T6 Ex II 1D Ex iaD 20 T 108 °C	2	
NJ1,5-18GM-N-D-V1	N.C.	1.5		embeddable	-25 ... 85 °C	connector M12 x 1, 4 pin	IP67	Ex II 2G Ex ia IIC T6 Ex II 1D Ex iaD 20 T 108 °C	2	
NJ5-18GK-N	N.C.	5		embeddable	-25 ... 100 °C	PVC cable	IP68	Ex II 2G Ex ia IIC T6 Ex II 1D Ex iaD 20 T 108 °C	2	
NJ5-18GK-SN	N.C.	5		embeddable	-40 ... 100 °C	silicon cable	IP68	Ex II 1G Ex ia IIC T6 Ex II 3G Ex ic IIC T6 X Ex II 1D Ex iaD 20 T 108 °C	3**	
NJ5-18GK-N-150	N.C.	5		embeddable	-40 ... 150 °C	SIHF cable	IP65	Ex II 1G Ex ia IIC T6	2	
NCB5-18GK40-N0	N.C.	5		embeddable	-25 ... 100 °C	PVC cable	IP67	Ex II 2G Ex ia IIC T6 Ex II 1D Ex iaD 20 T 108 °C	2	
NCB5-18GM40-N0	N.C.	5		embeddable	-25 ... 100 °C	PVC cable	IP67	Ex II 1G Ex ia IIC T6 Ex II 3G Ex nL IIC T6 X Ex II 3G Ex ic IIC T6 X Ex II 1D Ex iaD 20 T 108 °C Ex II 3D Ex tD A22 IP67 T80 °C X	2	
NCB5-18GM40-N0-V1	N.C.	5		embeddable	-25 ... 100 °C	connector M12 x 1, 4 pin	IP67	Ex II 1G Ex ia IIC T6 Ex II 1D Ex iaD 20 T 108 °C	2	
NJ5-18GM-N	N.C.	5		embeddable	-25 ... 100 °C	PVC cable	IP67	Ex II 1G Ex ia IIC T6 Ex II 1D Ex iaD 20 T 108 °C	2	
NJ5-18GM-N-V1	N.C.	5		embeddable	-25 ... 100 °C	connector M12 x 1, 4 pin	IP67	Ex II 1G Ex ia IIC T6	2	
NCB5-18GM70-N0	N.C.	5		embeddable	-25 ... 100 °C	PVC cable	IP67	Ex II 1G Ex ia IIC T6 Ex II 1D Ex iaD 20 T 108 °C	2	
NJ8-18GK-N	N.C.	8		not embeddable	-25 ... 100 °C	PVC cable	IP68	Ex II 2G Ex ia IIC T6 Ex II 1D Ex iaD 20 T 108 °C	2	
NJ8-18GK-SN	N.C.	8		not embeddable	-40 ... 100 °C	silicon cable	IP68	Ex II 1G Ex ia IIC T6 Ex II 3G Ex nL IIC T6 X Ex II 3G Ex ic IIC T6 X Ex II 1D Ex iaD 20 T 108 °C Ex II 3D Ex tD A22 IP67 T80 °C X	3**	
NJ8-18GK-N-150	N.C.	8		not embeddable	-40 ... 150 °C	SIHF cable	IP65	Ex II 1G Ex ia IIC T6	2	
NCN8-18GK40-N0	N.C.	8		not embeddable	-25 ... 100 °C	PVC cable	IP67	Ex II 2G Ex ia IIC T6 Ex II 1D Ex iaD 20 T 108 °C	2	
NCB8-18GM40-N0	N.C.	8	●	embeddable	-25 ... 100 °C	PVC cable	IP67	Ex II 1G Ex ia IIC T6 Ex II 3G Ex nL IIC T6 X Ex II 3G Ex ic IIC T6 X Ex II 3D Ex tD A22 IP67 T80 °C X	2	
NCB8-18GM40-N0-V1	N.C.	8	●	embeddable	-25 ... 100 °C	connector M12 x 1, 4 pin	IP67	Ex II 1G Ex ia IIC T6 Ex II 3G Ex ic IIC T6 X	2	
NCN8-18GM40-N0	N.C.	8		not embeddable	-25 ... 100 °C	PVC cable	IP67	Ex II 1G Ex ia IIC T6 Ex II 3G Ex nL IIC T6 X Ex II 3G Ex ic IIC T6 X Ex II 1D Ex iaD 20 T 108 °C Ex II 3D Ex tD A22 IP67 T80 °C X	2	
NCN8-18GM40-N0-V1	N.C.	8		not embeddable	-25 ... 100 °C	connector M12 x 1, 4 pin	IP67	Ex II 1G Ex ia IIC T6 Ex II 1D Ex iaD 20 T 108 °C	2	
NJ8-18GM-N	N.C.	8		not embeddable	-25 ... 100 °C	PVC cable	IP67	Ex II 1G Ex ia IIC T6	2	
NJ8-18GM-N-V1	N.C.	8		not embeddable	-25 ... 100 °C	connector M12 x 1, 4 pin	IP67	Ex II 1G Ex ia IIC T6	2	

¹⁾ Information on 2:1 technology from Pepperl+Fuchs you will find at page 59

^{**}) The SIL3 functionality can only be achieved if this safety sensor is operated with a suitable Pepperl+Fuchs switch amplifier, e.g. KFD2-SH-EX1.

For complete data and product description, see data sheet on www.pepperl-fuchs.com

Date of edition: 2009-08-27



- Plastic or stainless steel housing
- NAMUR interface
- High protection degree, up to IP68
- Extended temperature range down to -40 °C and up to +200 °C
- Applicable up to SIL2 acc. to IEC 61508
- Applicable up to SIL3 acc. to IEC 61508
NJ5-30GK-S1N
NJ10-30GK-SN
NJ15-30GK-SN
- Best visible LED
all ...N0 types

	Switching element function	Rated operating distance [mm]	2:1-Technology ^{*)}	Installation	Ambient temperature	Connection type	Protection degree	Ex-identification	SIL, acc. to IEC 61508	Wiring diagram
2 Wire, NAMUR										
NJ5-30GK-S1N	N.O.	5	I	embeddable	-25 ... 100 °C	silicon cable	IP68	II 1G Ex ia IIC T6 II 1D Ex iaD 20 T 108 °C	3 ^{**})	
NJ4-30GM-N-200	N.C.	4		embeddable	0 ... 200 °C	SIHF cable	IP65	II 1G Ex ia IIC T6	2	
NJ10-30GK-N	N.C.	10		embeddable	-25 ... 100 °C	PVC cable	IP68	II 2G Ex ia IIC T6 II 1D Ex iaD 20 T 108 °C	2	
NJ10-30GKK-N	N.C.	10		embeddable	-25 ... 100 °C	terminal compartment	IP67	II 2G Ex ia IIC T6	2	
NJ10-30GK-SN	N.C.	10		embeddable	-50 ... 100 °C	silicon cable	IP68	II 1G Ex ia IIC T6 II 1D Ex iaD 20 T 108 °C	3 ^{**})	
NCB10-30GK40-N0	N.C.	10		embeddable	-25 ... 100 °C	PVC cable	IP67	II 2G Ex ia IIC T6 II 1D Ex iaD 20 T 108 °C	2	
NJ10-30GM-N	N.C.	10		embeddable	-25 ... 100 °C	PVC cable	IP67	II 1G Ex ia IIC T6 II 1D Ex iaD 20 T 108 °C	2	
NJ10-30GM-N-V1	N.C.	10		embeddable	-25 ... 100 °C	connector M12 x 1, 4 pin	IP65	II 1G Ex ia IIC T6	2	
NCB10-30GM40-N0	N.C.	10	I	embeddable	-25 ... 100 °C	PVC cable	IP67	II 1G Ex ia IIC T6 II 3G Ex ic IIC T6 X II 1D Ex iaD 20 T 108 °C	2	
NCB10-30GM40-N0-V1	N.C.	10	I	embeddable	-25 ... 100 °C	connector M12 x 1, 4 pin	IP67	II 1G Ex ia IIC T6 II 1D Ex iaD 20 T 108 °C	2	
NCN15-30GK40-N0	N.C.	15		not embeddable	-25 ... 100 °C	PVC cable	IP67	II 2G Ex ia IIC T6 II 1D Ex iaD 20 T 108 °C	2	
NJ15-30GK-N	N.C.	15		not embeddable	-25 ... 100 °C	PVC cable	IP68	II 2G Ex ia IIC T6 II 1D Ex iaD 20 T 108 °C	2	
NJ15-30GKK-N	N.C.	15		not embeddable	-25 ... 100 °C	terminal compartment	IP67	II 2G Ex ia IIC T6	2	
NJ15-30GK-N-150	N.C.	15		not embeddable	-25 ... 150 °C	SIHF cable	IP65	II 1G Ex ia IIC T6	2	
NJ15-30GK-SN	N.C.	15		not embeddable	-40 ... 100 °C	silicon cable	IP68	II 1G Ex ia IIC T6 II 3G Ex nL IIC T6 X II 3G Ex ic IIC T6 X II 1D Ex iaD 20 T 108 °C II 3D Ex tD A22 IP67 T80°C X	3 ^{**})	
NJ15-30GM-N	N.C.	15		not embeddable	-25 ... 100 °C	PVC cable	IP67	II 1G Ex ia IIC T6 II 1D Ex iaD 20 T 108 °C	2	
NCB15-30GM40-N0	N.C.	15		quasi embeddable	-25 ... 100 °C	PVC cable	IP67	II 1G Ex ia IIC T6 II 3G Ex nL IIC T6 X II 3G Ex ic IIC T6 X II 3D Ex tD A22 IP67 T80°C X	2	
NCB15-30GM40-N0-V1	N.C.	15		quasi embeddable	-25 ... 100 °C	connector M12 x 1, 4 pin	IP67	II 1G Ex ia IIC T6 II 3G Ex nL IIC T6 X II 3G Ex ic IIC T6 X II 3D Ex tD A22 IP67 T80°C X	2	
NCN15-30GM40-N0	N.C.	15		not embeddable	-25 ... 100 °C	PVC cable	IP67	II 1G Ex ia IIC T6 II 1D Ex iaD 20 T 108 °C	2	
NCN15-30GM40-N0-V1	N.C.	15		not embeddable	-25 ... 100 °C	connector M12 x 1, 4 pin	IP67	II 1G Ex ia IIC T6 II 1D Ex iaD 20 T 108 °C	2	
NJ20-40-N	N.C.	20		not embeddable	-25 ... 100 °C	terminal compartment	IP67	II 2G Ex ia IIC T6	2	
NJ25-50-N	N.C.	25		not embeddable	-25 ... 100 °C	PVC cable	IP67	II 2G Ex ia IIC T6	2	

^{*)} Information on 2:1 technology from Pepperl+Fuchs you will find at Seite 59

^{**)} The SIL3 functionality can only be achieved if this safety sensor is operated with a suitable Pepperl+Fuchs switch amplifier, e.g. KFD2-SH-EX1.

For complete data and product description, see data sheet on www.pepperl-fuchs.com

Date of edition: 2009-08-27

Subject to modifications without notice

Pepperl+Fuchs Group
www.pepperl-fuchs.com

USA: +1 330 486 0001
fa-info@us.pepperl-fuchs.com

Germany: +49 621 776-4411
fa-info@pepperl-fuchs.com

Copyright Pepperl+Fuchs

Singapore: +65 6779 9091
fa-info@sg.pepperl-fuchs.com



- Brass or stainless steel housing
- Protection degree IP67
- Increased rated operating distance
NBB2-8GM40-E2-V1-3G-3D
NBB4-12GM50-E2-3G-3D
NBB4-12GM50-E2-V1-3G-3D
- Best visible LED

1.3

Switching element function	Rated operating distance [mm]	Installation	Ambient temperature	Connection type	Ex-identification	Wiring diagram
----------------------------	-------------------------------	--------------	---------------------	-----------------	-------------------	----------------

2 Wire, DC

NBB2-12GM40-Z0-V1-3G-3D	N.O.	2	embeddable	-25 ... 70 °C	connector M12 x 1, 4 pin	 	
NBB2-12GM40-Z0-3G-3D	N.O.	2	embeddable	-25 ... 70 °C	PVC cable	 	
NCN4-12GM40-Z0-3G-3D	N.O.	4	not embeddable	-25 ... 70 °C	PUR cable	 	

3 Wire, DC

NBB2-8GM40-E2-V1-3G-3D	PNP, N.O.	2	embeddable	-25 ... 70 °C	connector M12 x 1, 4 pin	 	
NBB2-12GM40-E2-3G-3D	PNP, N.O.	2	embeddable	-25 ... 70 °C	PUR cable	 	
NBB2-12GM40-E2-V1-3G-3D	PNP, N.O.	2	embeddable	-25 ... 70 °C	connector M12 x 1, 4 pin	 	
NCN4-12GM40-E2-3G-3D	PNP, N.O.	4	not embeddable	-25 ... 70 °C	PUR cable	 	
NCN4-12GM40-E2-V1-3G-3D	PNP, N.O.	4	not embeddable	-25 ... 70 °C	connector M12 x 1, 4 pin	 	
NBB4-12GM50-E2-3G-3D	PNP, N.O.	4	embeddable	-25 ... 70 °C	PVC cable	 	
NBB4-12GM50-E2-V1-3G-3D	PNP, N.O.	4	embeddable	-25 ... 70 °C	connector M12 x 1, 4 pin	 	

4 Wire, DC

NBB2-12GM60-A2-3G-3D	PNP, antivalent	2	embeddable	-25 ... 70 °C	PVC cable	 	
----------------------	-----------------	---	------------	---------------	-----------	------	--

Inductive Sensors, standard type sensors

For complete data and product description, see data sheet on www.pepperl-fuchs.com



- Brass or stainless steel housing
- Protection degree IP67
- Increased rated operating distance
 NBB8-18GM50-E2-V1-3G-3D
 NBB8-18GM50-E2-3G-3D
 NBB8-18GM60-A2-V1-3G-3D

	Switching element function	Rated operating distance [mm]	Installation	Ambient temperature	Connection type	Ex-identification	Wiring diagram
2 Wire, DC							
NCB5-18GM40-Z0-V1-3G-3D	N.O.	5	embeddable	-25 ... 70 °C	connector M12 x 1, 4 pin	⚠ II 3G Ex nA IIC T6 X ⚠ II 3D Ex tD A22 IP67 T80°C X	
NBB5-18GM40-Z0-3G-3D	N.O.	5	embeddable	-25 ... 70 °C	PVC cable	⚠ II 3G Ex nA IIC T6 X ⚠ II 3D Ex tD A22 IP67 T80°C X	
NCB5-18GM40-Z0-3G-3D	N.O.	5	embeddable	-25 ... 70 °C	PUR cable	⚠ II 3G Ex nA IIC T6 X ⚠ II 3D Ex tD A22 IP67 T80°C X	
NCN8-18GM40-Z0-3G-3D	N.O.	8	not embeddable	-25 ... 70 °C	PUR cable	⚠ II 3G Ex nA IIC T6 X ⚠ II 3D Ex tD A22 IP67 T80°C X	
3 Wire, DC							
NJ5-18GM50-E2-3G-3D	PNP, N.O.	5	embeddable	-25 ... 70 °C	PVC cable	⚠ II 3G Ex nA IIC T6 X ⚠ II 3D Ex tD A22 IP67 T80°C X	
NJ5-18GM50-E2-V1-3G-3D	PNP, N.O.	5	embeddable	-25 ... 70 °C	connector M12 x 1, 4 pin	⚠ II 3G Ex nA IIC T6 X ⚠ II 3D Ex tD A22 IP67 T80°C X	
NBB8-18GM50-E2-V1-3G-3D	PNP, N.O.	8	embeddable	-25 ... 70 °C	connector M12 x 1, 4 pin	⚠ II 3G Ex nA IIC T6 X ⚠ II 3D Ex tD A22 IP67 T80°C X	
NBB8-18GM50-E2-3G-3D	PNP, N.O.	8	embeddable	-25 ... 70 °C	PVC cable	⚠ II 3G Ex nA IIC T6 X ⚠ II 3D Ex tD A22 IP67 T80°C X	
NCN8-18GM50-E2-3G-3D	PNP, N.O.	8	not embeddable	-25 ... 70 °C	PVC cable	⚠ II 3G Ex nA IIC T6 X ⚠ II 3D Ex tD A22 IP67 T80°C X	
NCN8-18GM50-E2-V1-3G-3D	PNP, N.O.	8	not embeddable	-25 ... 70 °C	connector M12 x 1, 4 pin	⚠ II 3G Ex nA IIC T6 X ⚠ II 3D Ex tD A22 IP67 T80°C X	
4 Wire, DC							
NBB5-18GM60-A2-V1-3G-3D	PNP antivalent	5	embeddable	-25 ... 70 °C	connector M12 x 1, 4 pin	⚠ II 3G Ex nA IIC T6 X ⚠ II 3D Ex tD A22 IP67 T80°C X	
NBB8-18GM60-A2-V1-3G-3D	PNP antivalent	8	embeddable	-25 ... 70 °C	connector M12 x 1, 4 pin	⚠ II 3G Ex nA IIC T6 X ⚠ II 3D Ex tD A22 IP67 T80°C X	



- Brass or stainless steel housing
- Protection degree IP67
- Increased rated operating distance
NBB 15-30GM50-E2-3G-3D
NBB 15-30GM50-E2-V1-3G-3D

1.3

Inductive Sensors, standard type sensors

	Switching element function	Rated operating distance [mm]	Installation	Ambient temperature	Connection type	Ex-Identification	Wiring diagram
2 Wire, DC							
NCB10-30GM40-Z1-3G-3D	DC N.C.	10	embeddable	-25 ... 70 °C	PVC cable	Ⓧ II 3G Ex nA IIC T6 X Ⓧ II 3D Ex tD A22 IP67 T80°C X	
NCB10-30GM40-Z0-V1-3G-3D	DC N.O.	10	embeddable	-25 ... 70 °C	connector M12 x 1, 4 pin	Ⓧ II 3G Ex nA IIC T6 X Ⓧ II 3D Ex tD A22 IP67 T80°C X	
NCB10-30GM40-Z0-3G-3D	DC N.O.	10	embeddable	-25 ... 70 °C	PVC cable	Ⓧ II 3G Ex nA IIC T6 X Ⓧ II 3D Ex tD A22 IP67 T80°C X	
NBB10-30GM40-Z0-3G-3D	DC N.O.	10	embeddable	-25 ... 70 °C	PVC cable	Ⓧ II 3G Ex nA IIC T6 X Ⓧ II 3D Ex tD A22 IP67 T80°C X	
NCN15-30GM40-Z0-3G-3D	DC N.O.	15	not embeddable	-25 ... 70 °C	PVC cable	Ⓧ II 3G Ex nA IIC T6 X Ⓧ II 3D Ex tD A22 IP67 T80°C X	
3 Wire, DC							
NJ10-30GM50-E2-3G-3D	PNP N.O.	10	embeddable	-25 ... 70 °C	PVC cable	Ⓧ II 3G Ex nA IIC T6 X Ⓧ II 3D Ex tD A22 IP67 T80°C X	
NJ10-30GM50-E2-V1-3G-3D	PNP N.O.	10	embeddable	-25 ... 70 °C	connector M12 x 1, 4 pin	Ⓧ II 3G Ex nA IIC T6 X Ⓧ II 3D Ex tD A22 IP67 T80°C X	
NJ15-30GM50-E2-3G-3D	PNP N.O.	15	not embeddable	-25 ... 70 °C	PVC cable	Ⓧ II 3G Ex nA IIC T6 X Ⓧ II 3D Ex tD A22 IP67 T80°C X	
NJ15-30GM50-E2-V1-3G-3D	PNP N.O.	15	not embeddable	-25 ... 70 °C	connector M12 x 1, 4 pin	Ⓧ II 3G Ex nA IIC T6 X Ⓧ II 3D Ex tD A22 IP67 T80°C X	
NBB15-30GM50-E2-3G-3D	PNP N.O.	15	embeddable	-25 ... 70 °C	PVC cable	Ⓧ II 3G Ex nA IIC T6 X Ⓧ II 3D Ex tD A22 IP67 T80°C X	
NBB15-30GM50-E2-V1-3G-3D	PNP N.O.	15	embeddable	-25 ... 70 °C	connector M12 x 1, 4 pin	Ⓧ II 3G Ex nA IIC T6 X Ⓧ II 3D Ex tD A22 IP67 T80°C X	

For complete data and product description, see data sheet on www.pepperl-fuchs.com

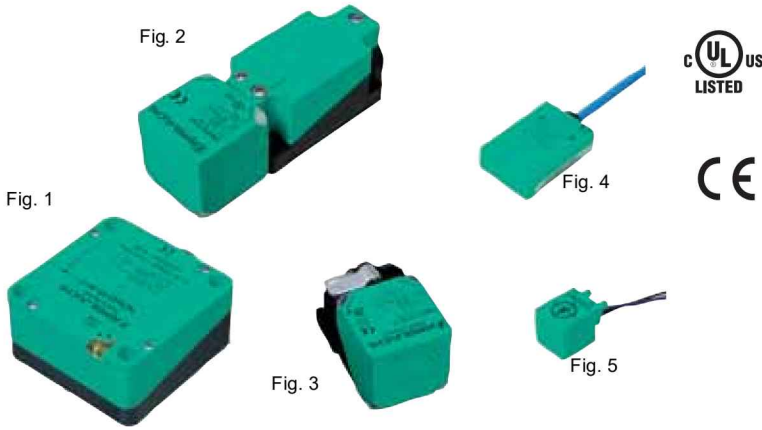

- **Extended temperature range down to -40 °C and up to +100 °C**
- **LEDs visible from all directions**
 NJ6S1+U1+N1
 NJ15S+U1+N
 NJ20S+U4+N
 NCB20-L2-N0-V1
 NCN40-L2-N0-V1
- **High protection degree up to IP69k**
- **Quick mounting bracket**
 NCB20-L2-N0-V1
 NCN40-L2-N0-V1

	Switching element function	Rated operating distance [mm]	Installation	Ambient temperature	Connection type	Protection degree	Ex-identification	SIL, acc. to IEC 61508	Figure	Wiring diagram
2 Wire, NAMUR										
NJ0,8-F-N	N.C.	0.8	embeddable	-25 ... 100 °C	PVC cable	IP67	Ex II 2G Ex ia IIC T6		5	
NJ1,5-F-N	N.C.	1.5	not embeddable	-25 ... 100 °C	LIFYW strands	IP68	Ex II 2G Ex ia IIC T6 Ex II 1D Ex iaD 20 T 108 °C		5	
NJ6-F-N	N.C.	6	embeddable	-25 ... 100 °C	PUR cable	IP67	Ex II 2G Ex ia IIC T6		4	
NJ6S1+U1+N1	N.O.	6	embeddable	-25 ... 100 °C	terminal compartment	IP68	Ex II 1G Ex ia IIC T6 Ex II 1D Ex iaD 20 T 108 °C	3**)	2	
NJ10-F-N	N.C.	10	not embeddable	-25 ... 100 °C	PUR cable	IP67	Ex II 2G Ex ia IIC T6		4	
NBB15-U1K-N0	N.C.	15	embeddable	-25 ... 100 °C	terminal compartment	IP67 / IP69K	Ex II 1G Ex ia IIC T6 Ex II 3G Ex ic IIC T6 X		2	
NBB15-U4K-N0-V1	N.C.	15	embeddable	-25 ... 100 °C	connector M12 x 1	IP67 / IP69K	Ex II 1G Ex ia IIC T6 Ex II 3G Ex ic IIC T6 X		2	
NJ15S+U1+N	N.C.	15	embeddable	-40 ... 100 °C	terminal compartment	IP68	Ex II 1G Ex ia IIC T6 Ex II 1D Ex iaD 20 T 108 °C	3**)	2	
NJ20S+U4+N	N.C.	20	not embeddable	-40 ... 100 °C	terminal compartment	IP68	Ex II 1G Ex ia IIC T6 Ex II 1D Ex iaD 20 T 108 °C	3**)	2	
NBB20-U1K-N0	N.C.	20	embeddable	-25 ... 100 °C	terminal compartment	IP67 / IP69K	Ex II 1G Ex ia IIC T6 Ex II 3G Ex ic IIC T6 X		2	
NCB20-L2-N0-V1	N.C.	20	embeddable	-25 ... 100 °C	connector M12 x 1	IP69K	Ex II 1G Ex ia IIC T6 Ex II 3G Ex nL IIC T6 X Ex II 3G Ex ic IIC T6 X Ex II 3D Ex tD A22 IP67 T80 °C X	2	3	
NBN30-U1K-N0	N.C.	30	not embeddable	-25 ... 100 °C	terminal compartment	IP67 / IP69K	Ex II 1G Ex ia IIC T6 Ex II 3G Ex ic IIC T6 X		2	
NBN30-U4K-N0-V1	N.C.	30	not embeddable	-25 ... 100 °C	connector M12 x 1	IP67 / IP69K	Ex II 1G Ex ia IIC T6 Ex II 3G Ex ic IIC T6 X		2	
NBN40-U1K-N0	N.C.	40	not embeddable	-25 ... 100 °C	terminal compartment	IP67 / IP69K	Ex II 1G Ex ia IIC T6 Ex II 3G Ex ic IIC T6 X		2	
NBN40-U1K-N0-V1	N.C.	40	not embeddable	-25 ... 100 °C	connector M12 x 1	IP67 / IP69K	Ex II 1G Ex ia IIC T6 Ex II 3G Ex ic IIC T6 X		2	
NBN40-U4K-N0-V1	N.C.	40	not embeddable	-25 ... 100 °C	connector M12 x 1	IP67 / IP69K	Ex II 1G Ex ia IIC T6 Ex II 3G Ex ic IIC T6 X		2	
NCN40-L2-N0-V1	N.C.	40	not embeddable	-25 ... 100 °C	connector M12 x 1	IP69K	Ex II 1G Ex ia IIC T6 Ex II 3G Ex nL IIC T6 X Ex II 3G Ex ic IIC T6 X Ex II 3D Ex tD A22 IP67 T80 °C X	2	3	
NCB40-FP-N0-P1	N.C.	40	embeddable	-25 ... 100 °C	terminal compartment	IP67	Ex II 1G Ex ia IIC T6 Ex II 1D Ex iaD 20 T 108 °C	2	1	
NCB40-FP-N0-P1-V1	N.C.	40	embeddable	-25 ... 100 °C	connector M12 x 1	IP67	Ex II 1G Ex ia IIC T6 Ex II 1D Ex iaD 20 T 108 °C		1	
NJ40-FP-SN-P1	N.C.	40	not embeddable	-40 ... 100 °C	terminal compartment	IP68	Ex II 2G Ex ia IIC T6 Ex II 1D Ex iaD 20 T 108 °C	3**)	1	
NCN50-FP-N0-P1	N.C.	50	not embeddable	-25 ... 100 °C	terminal compartment	IP67	Ex II 1G Ex ia IIC T6 Ex II 1D Ex iaD 20 T 108 °C	2	1	

***) The SIL3 functionality can only be achieved if this safety sensor is operated with a suitable Pepperl+Fuchs switch amplifier, e.g. KFD2-SH-EX1.

Series **VariKont** (-U... and +U...) and series **-FP** sensors consist of the sensor device and a base. The bases are available in different types. **VariKont**: -U1K and +U1 = plastic base (PA), -U4K and +U4 = metal base **FP**: P1 = plastic base (PBT), P4 = metal base

For complete data and product description, see data sheet on www.pepperl-fuchs.com

Date of edition: 2009-08-28

Subject to modifications without notice

Pepperl+Fuchs Group
www.pepperl-fuchs.com

USA: +1 330 486 0001
fa-info@us.pepperl-fuchs.com

Germany: +49 621 776-4411
fa-info@pepperl-fuchs.com

Copyright Pepperl+Fuchs

Singapore: +65 6779 9091
fa-info@sg.pepperl-fuchs.com

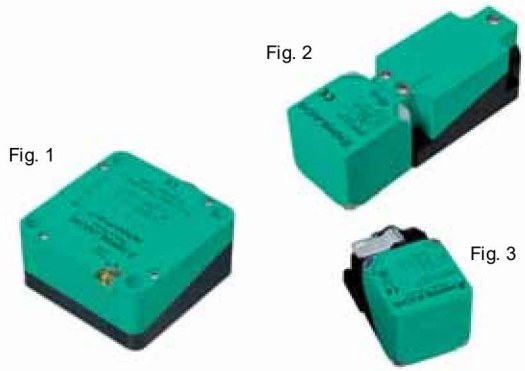

- High protection degree up to IP69K
- Extended temperature range up to +85 °C
- 4 indicator LEDs for 360° visibility
N...-U1K-...
N...-L2-...
- Quick mounting bracket
N...-L2-...



1.3

Inductive Sensors, standard type sensors

	Switching element function	Rated operating distance [mm]	Installation	Ambient temperature	Connection type	Protection degree	Ex-indication	Figure	Wiring diagram
3 Wire, DC									
NBB15-U1K-E2-3G-3D	PNP, N.O.	15	embeddable	-25 ... 85 °C	terminal compartment	IP67/ IP69K	II 3G Ex nA IIC T6 X II 3D Ex tD A22 IP67 T80°C X	2	
NBB20-U1K-E2-3G-3D	PNP, N.O.	20	embeddable	-25 ... 85 °C	terminal compartment	IP67/ IP69K	II 3G Ex nA IIC T6 X II 3D Ex tD A22 IP67 T80°C X	2	
NBB20-L2-E2-V1-3G-3D	PNP, N.O.	20	embeddable	-25 ... 85 °C	connector M12 x 1, 4 pin	IP69K	II 3G Ex nA IIC T6 X II 3D Ex tD A22 IP67 T80°C X	3	
NBN30-U1K-E2-3G-3D	PNP, N.O.	30	not embeddable	-25 ... 85 °C	terminal compartment	IP67/ IP69K	II 3G Ex nA IIC T6 X II 3D Ex tD A22 IP67 T80°C X	2	
NBN40-U1K-E2-3G-3D	PNP, N.O.	40	not embeddable	-25 ... 85 °C	terminal compartment	IP67/ IP69K	II 3G Ex nA IIC T6 X II 3D Ex tD A22 IP67 T80°C X	2	
NBN40-L2-E2-V1-3G-3D	PNP, N.O.	40	not embeddable	-25 ... 85 °C	connector M12 x 1, 4 pin	IP69K	II 3G Ex nA IIC T6 X II 3D Ex tD A22 IP67 T80°C X	3	
NCB50-FP-E2-P1-V1-3G-3D	PNP, N.O.	50	embeddable	-25 ... 70 °C	connector M12 x 1, 4 pin	IP67	II 3G Ex nA IIC T6 X II 3D Ex tD A22 IP67 T80°C X	1	
4 Wire, DC									
NBB20-L2-A2-V1-3G-3D	PNP antivalent	20	embeddable	-25 ... 85 °C	connector M12 x 1, 4 pin	IP69K	II 3G Ex nA IIC T6 X II 3D Ex tD A22 IP67 T80°C X	3	
NBN40-L2-A2-V1-3G-3D	PNP antivalent	40	not embeddable	-25 ... 85 °C	connector M12 x 1, 4 pin	IP69K	II 3G Ex nA IIC T6 X II 3D Ex tD A22 IP67 T80°C X	3	
NCB40-FP-A2-P1-3G-3D	PNP antivalent	40	embeddable	-25 ... 70 °C	terminal compartment	IP68	II 3G Ex nA IIC T6 X II 3D Ex tD A22 IP67 T80°C X	1	
NCN50-FP-A2-P1-3G-3D	PNP antivalent	50	not embeddable	-25 ... 70 °C	terminal compartment	IP67	II 3G Ex nA IIC T6 X II 3D Ex tD A22 IP67 T80°C X	1	
NCB50-FP-A2-P1-3G-3D	PNP antivalent	50	embeddable	-25 ... 70 °C	terminal compartment	IP67	II 3G Ex nA IIC T6 X II 3D Ex tD A22 IP67 T80°C X	1	

Series **VariKont** (-U... and +U...) and series **-FP** sensors consist of the sensor device and a base. The bases are available in different types.

VariKont: -U1K and +U1 = plastic base (PA), -U4K and +U4 = metal base
FP: P1 = plastic base (PBT), P4 = metal base

For complete data and product description, see data sheet on www.pepperl-fuchs.com



CE
0102

- Diameter 10 mm ... 43 mm
- Direction detection by means of bistable switching behavior
RC10-14-N3
RC15-14-N3
- High passage speed 10 m/s
RC15-14-N3

	Switching element function	Innendurchmesser	Ambient temperature	Connection type	Protection degree	Ex-identification	SIL, acc. to IEC 61608	Figure	Wiring diagram
2 Wire, NAMUR									
RC10-14-N0	N.C.	10 mm	-20 ... 65 °C	PVC cable	IP67	Ex II 2G Ex ia IIC T6	2	2	
RC10-14-N3	bistable	10 mm	-20 ... 100 °C	PVC cable	IP67	Ex II 2G Ex ia IIC T6		2	
RJ15--N	N.C.	15 mm	-25 ... 70 °C	PVC cable	IP67	Ex II 2G Ex ia IIC T6		1	
RJ15-14-N	N.C.	15 mm	-25 ... 70 °C	PVC cable	IP67	Ex II 2G Ex ia IIC T6		2	
RC15-14-N0	N.C.	15 mm	-20 ... 65 °C	PVC cable	IP67	Ex II 2G Ex ia IIC T6	2	2	
RC15-14-N3	bistable	15 mm	-20 ... 70 °C	PVC cable	IP67	Ex II 2G Ex ia IIC T6		2	
RJ21-N	N.C.	21 mm	-25 ... 70 °C	PVC cable	IP67	Ex II 2G Ex ia IIC T6		3	
RJ43-N	N.C.	43 mm	-25 ... 70 °C	PVC cable	IP67	Ex II 2G Ex ia IIC T6		4	

Inductive position measurement systems

Pinpoint position detection plays a central role in many industrial processes. Depending on the application in question, the process may involve determining the position of linear moving units such as workpiece or tool carriers or detecting angles of valve actuators.

For all these applications, Pepperl+Fuchs offers suitable non-contact operating sensors and sensor systems for industrial use.



A number of position measurement systems for high precision detection of linear and rotary movements are available. Their inductive operating principle makes these systems highly resistant to dirt. The possible measuring lengths cover a range from a few millimeters up to a meter, or a range of angles from 0 to 360 degrees. Depending on the version, in addition to the standard analog output for displaying the calculated position, further freely configurable switch outputs are available for up to three positions as a separate switching signal.

Inductive instead of magnetic

Due to the inevitable further development of the inductive sensor, Pepperl+Fuchs developers have created innovative position and angle sensors that function inductively, in contrast to standard magnetic systems.



In one device, a number of coils are arranged in such a way that several coil systems are always simultaneously damped by one target element.

With the aid of an integrated control interface, an output signal proportional to displacement can be calculated. The determined position is output as an absolute value and is also immediately available after switching on the sensor, without inconvenient referencing.

Simple steel targets

Apart from the robustness due to the encapsulated housing, the main advantage of inductive systems is the use of non-magnetic steel targets.

Compared to conventional magnetic systems, this clearly reduces the danger of failure of the measuring system from contaminants due to metallic abrasion.

Also suitable for precise angle position detection

The F130 model is the counterpart to the linear position measurement systems for angle measurement. The coils are in a circular arrangement.



The compact sensor enables non-contact detection of angle positions from 0° to 360°.

High resolution and accuracy

A key strength of the inductive position measurement and angle positioning systems is the high angle resolution, despite the non-contact angle detection. The microcontroller-based evaluation enables a direction resolution of up to 33 µm or angle resolution of 0.09°, so the smallest alterations can be detected, which is ideal for high-quality applications in the Machine Tool Manufacturing Industry.

The measured value is superimposed on an analog voltage or current signal at the output. Thanks to the simultaneous evaluation of several coil systems, the highly precise sensors achieve a measurement accuracy of up to ±0.3 mm.

Different measuring lengths

For linear position measurement, there are various designs to choose from. They cover measurement lengths from 80 mm to 960 mm depending on design. The inductive angle sensor of the F130 series has a measurement range of 0° to 360°.

Integrated safety functions

The intelligent sensors register if the actuating element is beyond the measurement and detection range and, via a fault signal, transmit a message to the higher level control.



Date of edition: 2009-09-01

1.4

Inductive Sensors, analog positioning systems



- Analog voltage and current outputs
- Up to 3 free adjustable switching outputs
- Measuring range 0 ... 120 mm (length)
Series F90
- Measuring range 0 ... 960 mm (length)
Series F110
- Measuring range 0 ... 360° (angle)
Series F130

	Measuring range	Switching output	Analog output	Protection degree	Wiring diagram
Linear measurement with adjustable switching and analog outputs					
PMI80-F90-IUE8-V15	0 ... 80 mm	2 switching outputs pnp, N.O.	1 current output or voltage output, depends on load 4 ... 20 mA / 0 ... 5 V	IP67	
PMI104-F90-IUE8-V15	0 ... 104 mm	2 switching outputs pnp, N.O.	1 current output or voltage output, depends on load 4 ... 20 mA / 0 ... 5 V	IP67	
PMI120-F90-IUE8-V15	0 ... 120 mm	2 switching outputs pnp, N.O.	1 current output or voltage output, depends on load 4 ... 20 mA / 0 ... 5 V	IP67	
Linear measurement with 2 analog outputs					
PMI80-F90-IU-V15	0 ... 80 mm		1 current output: 4 ... 20 mA 1 voltage output: 0 ... 10 V	IP67	
PM104-F90-IU-V15	0 ... 104 mm		1 current output: 4 ... 20 mA 1 voltage output: 0 ... 10 V	IP67	
PMI120-F90-IU-V15	0 ... 120 mm		1 current output: 4 ... 20 mA 1 voltage output: 0 ... 10 V	IP67	
PMI210-F110-IU-V1	0 ... 210 mm		1 current output: 4 ... 20 mA 1 voltage output: 0 ... 10 V	IP65	
PMI360-F110-IU-V1	0 ... 360 mm		1 current output: 4 ... 20 mA 1 voltage output: 0 ... 10 V	IP65	
PMI510-F110-IU-V1	0 ... 510 mm		1 current output: 4 ... 20 mA 1 voltage output: 0 ... 10 V	IP65	
PMI810-F110-IU-V1	0 ... 810 mm		1 current output: 4 ... 20 mA 1 voltage output: 0 ... 10 V	IP65	
PMI960-F110-IU-V1	0 ... 960 mm		1 current output: 4 ... 20 mA 1 voltage output: 0 ... 10 V	IP65	
Angle measurement with adjustable switching and analog outputs					
PMI360D-F130-IE8-V15	0 ... 360°	2 switching outputs pnp, N.O.	1 current output: 4 ... 20 mA	IP67	

Accessories

Series F90			Series F110			Series F130
MH-F90	BT-F90-G	BT-F90-W	MH-F110	BT-F110-G	BT-F110-W	BT-F130-A
Mounting bracket	Target	Target	Mounting bracket	Target	Target	Target

Date of edition: 2009-09-01

For complete data and product description, see data sheet on www.pepperl-fuchs.com

Subject to modifications without notice

Pepperl+Fuchs Group
www.pepperl-fuchs.com

USA: +1 330 486 0001
fa-info@us.pepperl-fuchs.com

Germany: +49 621 776-4411
fa-info@pepperl-fuchs.com

Copyright Pepperl+Fuchs

Singapore: +65 6779 9091
fa-info@sg.pepperl-fuchs.com

1. Capacitive sensors

Capacitive sensors work just like inductive sensors, non-contact and reaction-free. They complement them in areas of application where the inductive function principle fails. In addition to conducting materials, capacitive sensors can detect non-conducting materials such as glass, plastic, bulk solids, and liquids.

Depending on the material of a non-conductive target, different changes in capacitance result. This effect is noticeable in the output of a capacitive sensor as a signal change. Therefore, similar to inductive sensors, a reduction factor is defined depending on the material.

Capacitive sensors are used in direct monitoring of flow and fill levels.

Features at a glance:

- Cylindrical sensors in plastic or stainless steel enclosures
- Slimline designs with a height of just 5 mm
- Sensing range up to 40 mm

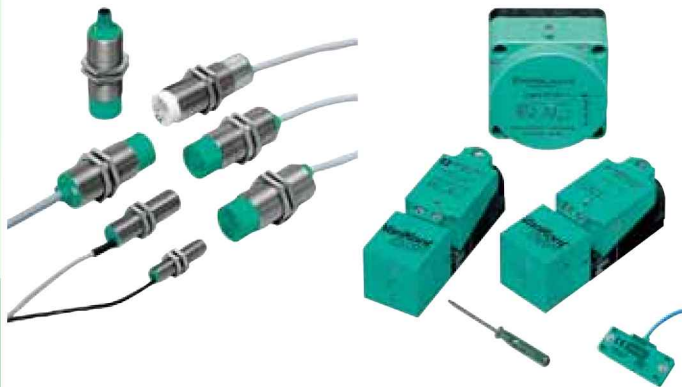

Series F46(A)

Due to its compact, flat design, series F46 offers some features which make it particularly suitable for certain applications. They can be mounted directly onto metal parts. The sensor's electronics are shielded due to the special arrangement of the sensor electrode. Therefore, the sensors can be mounted with no spacing. The close arrangement permits the determination of positions, speeds, and movements. In addition, this high degree of shielding from external fields provides the sensor with superior EMC features.

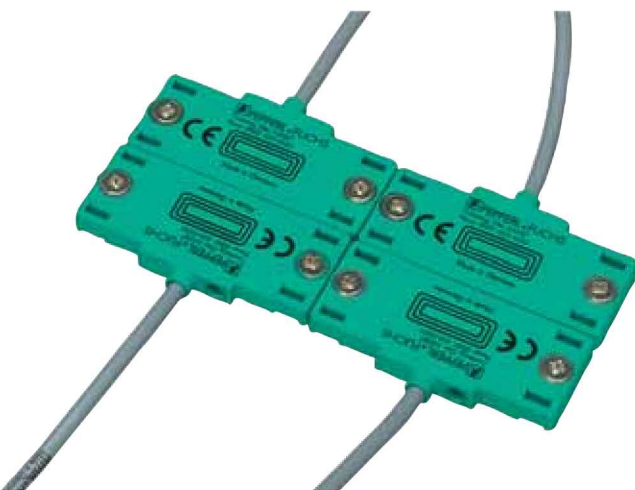

They are able to penetrate non-conducting materials such as thin wooden panels and hose or pipe walls. Four mounting holes make mounting with tie-wraps extremely simple, e.g. on hoses for detecting liquid.

Chemical resistance

In the F46A version, the sensor features a chemically-resistant enclosure. This makes it particularly suitable for use under the harshest of conditions. In addition to degree of protection IP68 (submersion resistance), it also fulfills IP69k (steam jet protection). With its PVDF housing and the FEP connecting cable, it is the ideal solution for the Chemical Industry.

2. Magnetic field sensors

Our range of magnetic field sensors includes various series for standard application of magnet detection. This enables applications such as, non-contact position detection of pistons in steel cylinders. For this application, the permanent magnets installed in small bores in the pistons are available as accessories from Pepperl+Fuchs.

Magnetic field sensors provide a comparatively large sensing range. They can be completely encapsulated in metal housings. Due to their exclusive sensitivity for magnets, they are extremely immune to noise. This feature allows completely new areas of application, in particular, under extreme conditions.

The responsiveness of a magnetic field sensor is dependent on the mechanical orientation of the magnets. Due to this characteristic, it can be used for "difficult" applications.

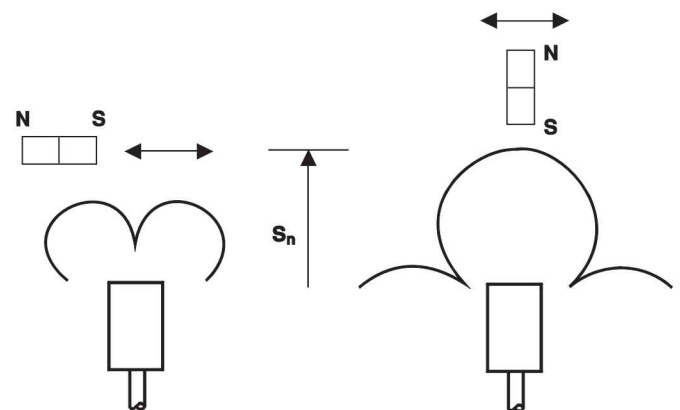

2

Capacitive Sensors / Magnetic Sensors



- The switching distance can be set over a wide range with the potentiometer
- High protection degree up to IP68
- Plain construction
Series F46(A)
- Installation holes for binders
Series F46(A)
- Detection of dry styrofoam granules
CJ6-18GK-N-Y.....
- Chemical resistant PVDF housing
Series F46A

	Switching element function	Rated operating distance [mm]	Installation	cylindrical style	Ambient temperature	Connection type	Protection degree	Ex-identification	Wiring diagram
--	----------------------------	-------------------------------	--------------	-------------------	---------------------	-----------------	-------------------	-------------------	----------------

2 Wire, NAMUR									
CJ1-12GK-N	N.O.	1	not embeddable	x	-25 ... 70 °C	PVC cable	IP68	II 1G Ex ia IIC T6 II 1D Ex iaD 20 T 85 °C	
CJ2-18GK-N	N.O.	2	not embeddable	x	-25 ... 70 °C	PVC cable	IP68	II 1G Ex ia IIC T6 II 1D Ex iaD 20 T 85 °C	
CJ4-12GK-N	N.O.	4	not embeddable	x	-25 ... 70 °C	PVC cable	IP68	II 1G Ex ia IIC T6 II 1D Ex iaD 20 T 85 °C	
CJ6-18GK-N	N.O.	6	not embeddable	x	-25 ... 70 °C	PVC cable	IP68	II 1G Ex ia IIC T6 II 1D Ex iaD 20 T 85 °C	
CJ15-40-N	N.O.	15	embeddable	x	-25 ... 70 °C	terminal compartment	IP65	II 1G Ex ia IIC T6 II 1D Ex iaD 20 T 85 °C	
CJ40-FP-N-P1	N.O.	40	not embeddable	-	-25 ... 70 °C	terminal compartment	IP65	II 1G Ex ia IIC T6 II 1D Ex iaD 20 T 85 °C	
CJ40-FP-N-P4	N.O.	40	not embeddable	-	-25 ... 70 °C	terminal compartment	IP65	II 1G Ex ia IIC T6 II 1D Ex iaD 20 T 85 °C	
CBN2-F46-N1	N.O.	2	not embeddable	-	-25 ... 70 °C	PUR cable	IP67	II 1G Ex ia IIC T6 II 1D Ex iaD 20 T 85 °C	
CBN5-F46-N1	N.O.	5	not embeddable	-	-25 ... 70 °C	PUR cable	IP67	II 1G Ex ia IIC T6 II 1D Ex iaD 20 T 85 °C	
CCN5-F46A-N1	N.O.	5	not embeddable	-	-25 ... 70 °C	PVDF cable	IP68	II 1G Ex ia IIC T6 II 1D Ex iaD 20 T 85 °C	
CBN10-F46-N1	N.O.	10	not embeddable	-	-25 ... 70 °C	PUR cable	IP67	II 1G Ex ia IIC T6 II 1D Ex iaD 20 T 85 °C	
CCN10-F46A-N1	N.O.	10	not embeddable	-	-25 ... 70 °C	PVDF cable	IP68	II 1G Ex ia IIC T6 II 1D Ex iaD 20 T 85 °C	
CCB10-30GM80-N1	N.O.	10	embeddable	x	-20 ... 70 °C	PVC cable	IP67	II 1G Ex ia IIC T6 II 1D Ex iaD 20 T 85 °C	
CCB10-30GM80-N1-V1	N.O.	10	embeddable	x	-20 ... 70 °C	Connector M12 x 1	IP67	II 1G Ex ia IIC T6 II 1D Ex iaD 20 T 85 °C	

3 Wire, DC									
CJ10-30GM-E2-3G-3D	PNP N.O.	10	embeddable	x	-25 ... 70 °C	PVC cable	IP67	II 3G Ex nA IIC T6 X II 3D IP67 T 90 °C X II 3D Ex tD A22 IP67 T80°C X	

4 Wire, DC									
CJ10-30GK-A2-3D	PNP antivalent	10	embeddable	x	-25 ... 70 °C	PVC cable	IP65	II 3D IP65 T 91 X	
CJ10-30GM-A2-3D	PNP antivalent	10	embeddable	x	-25 ... 70 °C	PVC cable	IP67	II 3D IP67 T 89 X	
CJ40-FP-A2-P1-3D	PNP antivalent	40	not embeddable	-	-25 ... 70 °C	terminal compartment	IP65	II 3D IP65 T 97 °C X	

Date of edition: 2009-08-27

For complete data and product description, see data sheet on www.pepperl-fuchs.com

Subject to modifications without notice

Pepperl+Fuchs Group
www.pepperl-fuchs.com

USA: +1 330 486 0001
fa-info@us.pepperl-fuchs.com

Germany: +49 621 776-4411
fa-info@pepperl-fuchs.com

Copyright Pepperl+Fuchs

Singapore: +65 6779 9091
fa-info@sg.pepperl-fuchs.com



- **60 mm embeddable with permanent magnet**
DM 60-31-15
MC60-12GM50-1N
MC60-12GM50-1N-V1
- **35 mm embeddable**
MJ35-F12-1N
- **5 mm not embeddable**
MBN5-V3-N

Switching element function	Rated operating distance [mm]	Installation	Ambient temperature	Connection type	Protection degree	Ex-identification	Wiring diagram
----------------------------	-------------------------------	--------------	---------------------	-----------------	-------------------	-------------------	----------------

2 Wire, NAMUR							
MBN5-V3-N	N.C.	5	not embeddable	-25 ... 75 °C	PVC cable	IP67	
MJ35-F12-1N	N.O.	35	embeddable	-25 ... 70 °C	PVC cable	IP67	
MC60-12GM50-1N	N.O.	60	embeddable	-25 ... 70 °C	PVC cable	IP67	
MC60-12GM50-1N-V1	N.O.	60	embeddable	-25 ... 70 °C	Connector M12 x 1, 4 pin	IP67	

Accessories for Magnetic Field Sensors

Clamping straps acc. to DIN 3017, stainless steel, strap width 9 mm, strap thickness 0.70 mm, hexagonal screw size 6

Clamping strap	Designation	suitable for hydraulic cylinders with ...
SB 40-60 09R	Clamping strap	Ø30 ... 48 mm
SB 50-70 09R	Clamping strap	Ø40 ... 58 mm
SB 60-80 09R	Clamping strap	Ø50 ... 68 mm
SB 70-90 09R	Clamping strap	Ø60 ... 78 mm

Clamping straps with screw

Stainless steel, strap width 10 mm, strap thickness 0.5 mm

Clamping strap	Designation	suitable for hydraulic cylinders with ...
SB 10M 10R	Clamping strap, 10 m roll	Ø > 70 mm
SBS 100 R	Screw	-

Permanent magnets

DM 06-05 NDFEB	DM 10-10 NDFEB	DM 20-10 NDFEB	DM 25-32-07	DM 60-31-15
Material: NdFeB Coating: Ni + Sn Ambient Temperature: max. 120 °C Packing unit 20 items	Material: NdFeB Coating: Ni + Sn Ambient Temperature: max. 120 °C	Material: NdFeB Coating: Ni + Sn Ambient Temperature: max. 120 °C	Material: BaFe with steel jacket Ambient Temperature: -40 ... 85 °C	Material: SrFe Ambient Temperature: max. 200 °C

Type DM ... NDFEB magnets are intended for installation in the cylinder piston.

For complete data and product description, see data sheet on www.pepperl-fuchs.com

Date of edition: 2009-08-27

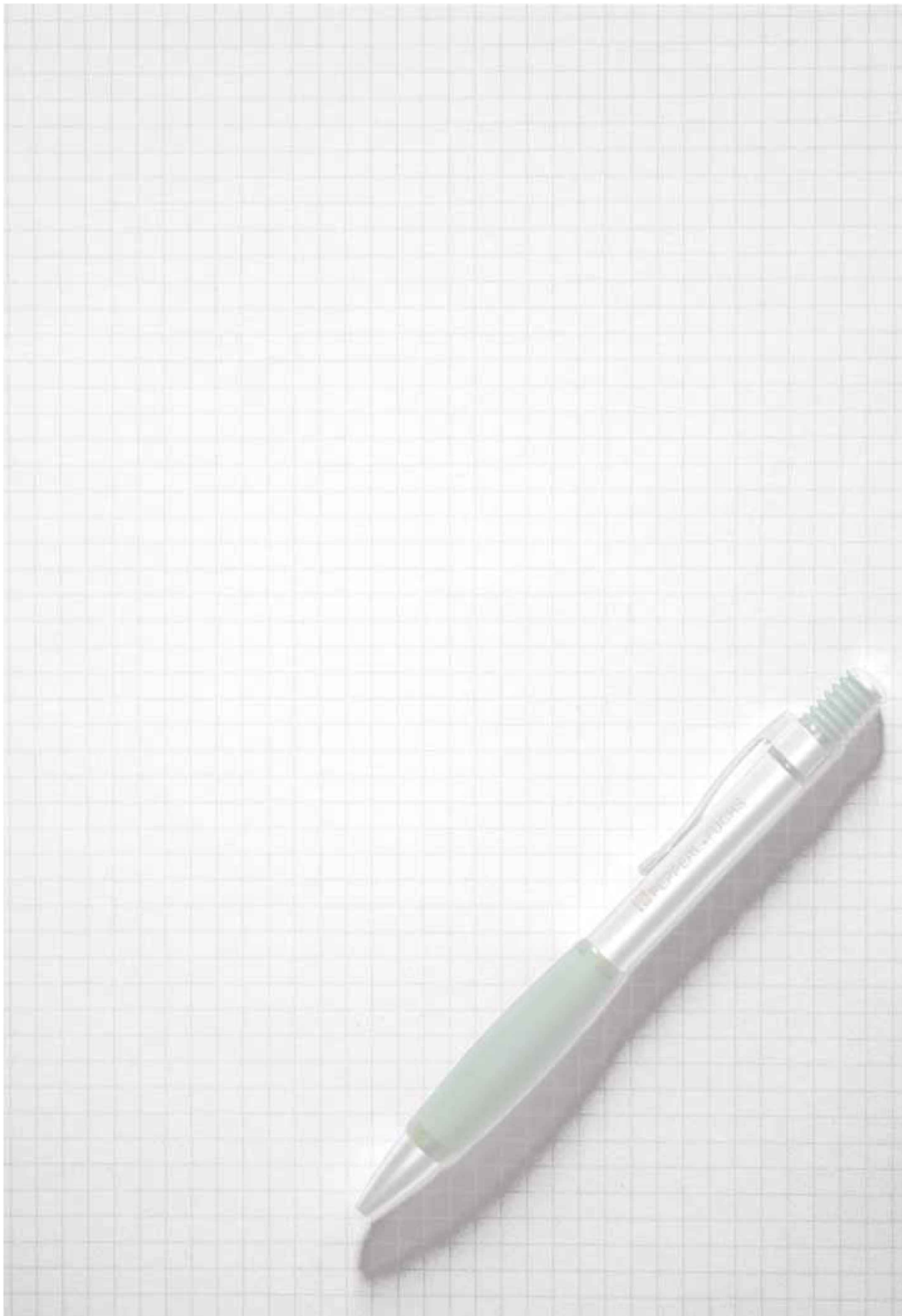

Date of edition: 2009-08-27

Subject to modifications without notice

Pepperl+Fuchs Group
www.pepperl-fuchs.com

USA: +1 330 486 0001
fa-info@us.pepperl-fuchs.com

Germany: +49 621 776-4411
fa-info@pepperl-fuchs.com

Copyright Pepperl+Fuchs

Singapore: +65 6779 9091
fa-info@sg.pepperl-fuchs.com



3

Photoelectric Sensors

Date of edition: 2009-08-26

Photoelectric sensors

Detection, acquisition, positioning, classifying, counting, signaling, and monitoring. Today, processes such as these are predominantly performed by non-contact photoelectric sensors.

Applications cover all areas of industry. Pepperl+Fuchs offers one of the largest ranges of photoelectric sensors under its VISOLUX trademark. We have the right photoelectric sensor for your application.



Because of their special features, photoelectric sensors from Pepperl+Fuchs provide you with economical procurement, efficiency in use and the highest reliability, even under critical conditions.

Overview of operating principles

The system design and choice of suitable sensor types depends upon the type, size, shape, and surface characteristics of the object to be detected, the distance between the sensor, and object and ambient conditions.

1. Thru-beam sensors

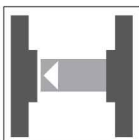

The transmitters and receivers of the thru-beam sensors are housed in distinct, separately arranged housings. The transmitter sends a light beam directly to the receiver. If a light beam is interrupted, the switching function is triggered.

2. Fork type sensors

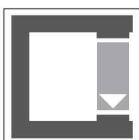

If a short distance of just a few millimeters or centimeters has to be bridged between the transmitter and the receiver, both can be housed opposite one another in a U-shaped housing. As only one device needs to be wired, fork type sensors enjoy the advantage of simplified electrical installation compared to

a normal thru-beam sensor. Furthermore, the optical axes do not need to be adjusted.

3. Retro-reflective sensors

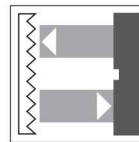

The retro-reflective sensor contains a transmitter and receiver incorporated in a single enclosure. The transmitter light is reflected back to the receiver by a reflector. When the light beam is interrupted, the switch function is triggered.

The typical problem for reflection systems, that glossy and reflective surfaces are not reliably recognized, is eliminated in the vast majority of sensors with the VISOLUX trademark by the use of polarization filters.

Subtypes of retro-reflective sensor are:

- Retro-reflective sensor with foreground suppression
- Retro-reflective sensor for clear glass/foil detection

4. Diffuse mode sensor

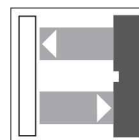

The diffuse mode sensor is, in principle, constructed like a retro-reflective sensor. However, it has no reflector and the light reflected from the detected object is evaluated by the receiver.

Due to the diffuse reflection (remission) from the object, the sensing range of the sensor is reduced compared to a retro-reflective sensor. This is referred to as sensing range.

Subtypes of diffuse mode sensor are:

- Background suppression sensor
- Background evaluation sensor
- Contrast sensor

5. Light curtains/light grid



The light curtain/light grid consists of a transmitter and a receiver which form a photoelectric protective device. The protection field is formed by an infrared light beam. The distance

between the individual beams determines the minimum resolution of an object that will be safely detected in the protective field area.



Fig 1



Fig 2



Fig 3



- ATEX approval for zone 2
- Optimised for the detection of small parts
- High switching frequency
- Sensitivity adjuster and light/dark switch as standard features of this series
- Infrared light
- Protection degree IP67

	Fork width [mm]	Supply voltage [VDC]	Signal output	Ambient temperature [°C]	Protection degree	Connection type	EX-identification	Figure	SIL, acc. to IEC 60508	Wiring diagram
3 Wire, DC										
GL30-IR-EX2/32/40a/98a	30	10 ... 30	1 PNP	-20 ... 60	IP67	Connector M8 x 1, 3 pin	⊕ Ex II 3G Ex op is nA IIC T6 Gc X	1		
GL50-IR-EX2/32/40a/98a	50	10 ... 30	1 PNP	-20 ... 60	IP67	Connector M8 x 1, 3 pin	⊕ Ex II 3G Ex op is nA IIC T6 Gc X	1		
GL80-IR-EX2/32/40a/98a	80	10 ... 30	1 PNP	-20 ... 60	IP67	Connector M8 x 1, 3 pin	⊕ Ex II 3G Ex op is nA IIC T6 Gc X	2		
GL121-IR-EX2/32/40a/98a	121	10 ... 30	1 PNP	-20 ... 60	IP67	Connector M8 x 1, 3 pin	⊕ Ex II 3G Ex op is nA IIC T6 Gc X	3		



Date of edition: 2009-08-27

For complete data and product description, see data sheet on www.pepperl-fuchs.com



Fig. 1



Fig. 2



Fig. 3



- **ATEX approval for zone 1**
M11/MV11-Ex/40b/112
L36/LV36-Ex/40b/116
- **Intrinsic safe**
M11/MV11-Ex/40b/112
L36/LV36-Ex/40b/116
- **ATEX approval for zone 2 and zone 22**
L32/LV32-Ex2...
- **Sleek design, especially for storage and conveyor systems**
L32/LV32-Ex2...
- **Scratch-resistant and solvent resistant glass lens**
L32/LV32-Ex2...

	Sensing range [m]	Supply voltage [V DC]	Test input	Signal output	Ambient temperature [°C]	Protection degree	Connection type	Ex-identification	Figure	SIL, acc. to IEC 60508	Wiring diagram
2 Wire, NAMUR											
M11/MV11-Ex/40b/112	10	6 ... 16	-	NAMUR, N.O./N.C.	-25 ... 70	IP67	Connector M12 x 1, 4 pin	Ex II 2G Ex op is ia IIC T6	1	2	
L36/LV36-Ex/40b/116	30	6 ... 16	-	NAMUR, N.O./N.C.	-25 ... 70	IP54	Terminal compartment	Ex II 2G Ex op is ia IIC T4	2	2	
3 Wire, DC											
L32/LV32-Ex2/47/73c	10	10 ... 30	Emitter cutoff	2 PNP, antivalent	-20 ... 50	IP65	Connector M12 x 1, 4 pin	Ex II 3G Ex nA op is II T4 Ex II 3D Ex tD A22IP65 T 75°C	3		
L32/LV32-Ex2/35/47/73C	30	10 ... 30	Emitter cutoff	2 PNP, antivalent	-20 ... 50	IP65	Connector M12 x 1, 4 pin	Ex II 3G Ex nA op is II T4 Ex II 3D Ex tD A22IP65 T 75°C	3		

Date of edition: 2009-08-27

For complete data and product description, see data sheet on www.pepperl-fuchs.com

Subject to modifications without notice

Pepperl+Fuchs Group
www.pepperl-fuchs.com

USA: +1 330 486 0001
fa-info@us.pepperl-fuchs.com

Germany: +49 621 776-4411
fa-info@pepperl-fuchs.com

Copyright Pepperl+Fuchs

Singapore: +65 6779 9091
fa-info@sg.pepperl-fuchs.com



- Sleek design, especially for storage and conveyor systems
RL32-54-Ex2...
- Glare protected with polarization filter
- Scratch-resistant and solvent resistant glass lens
RL32-54-Ex2...
OCS2000-M1K-N2
RL36-55-Ex/40b/116
- Adjustable sensor head
OCS2000-M1K-N2

	Sensing range [m]	Supply voltage [V DC]	Signal output	Ambient temperature [°C]	Protection degree	Connection type	Ex-identification	Figure	SIL, acc. to IEC 60508	Wiring diagram
2 Wire, NAMUR										
OCS2000-M1K-N2	2	6 ... 20	NAMUR, N.O./N.C.	-25 ... 70	IP67	Terminal compartment	ⓧ II 2G Ex op is ia IIC T6 ⓧ II 1D Ex iaD 20 T 85°C	1		
MLV11-54-Ex/40b/112	3	6 ... 20	NAMUR, N.O./N.C.	-25 ... 70	IP67	Connector M12 x 1, 4 pin	ⓧ II 2G Ex op is ia IIC T6	2		
RL36-55-Ex/40b/116	8	6 ... 20	1NAMUR, N.O./N.C.	-25 ... 70	IP54	Terminal compartment	ⓧ II 2G Ex op is ia IIC T4	3		
4 Wire, DC										
RL32-54-Ex2/47/73c	4	10 ... 30	2 PNP, antivalent	-20 ... 50	IP65	Connector M12 x 1, 4 pin	ⓧ II 3G Ex nA op is II T4 ⓧ II 3D Ex tD A22 IP65 T 75°C	4		
RL32-55-Ex2/47/73c	10	10 ... 30	2 PNP, antivalent	-20 ... 50	IP65	Connector M12 x 1, 4 pin	ⓧ II 3G Ex nA op is II T4 ⓧ II 3D Ex tD A22 IP65 T 75°C	4		

3 Reflectors for Retro-Reflective Sensors

A wide range of reflectors that are used with retro-reflective sensors as reference targets can be found in our accessories. They are available in a wide range of shapes, sizes, and methods of attachment. We have the right reflector for each application.

Model number	Description
C110-2	Diameter 84 mm with central mounting hole
H50	50.9 mm x 50.9 mm corner cube with slotted mounting holes on a lateral bracket
VR10	60 mm x 19 mm corner cube with 2 opposite mounting holes
H60	40.5 mm x 60 mm corner cube with 2 diagonal mounting holes
H85-2	84.5 mm x 84.5 mm square corner cube with 2 diagonal mounting holes
H160	60 mm x 18 mm corner cube with 2 opposite mounting holes
OFR-100/100	Reflective tape 100 mm x 100 mm, self adhesive



For complete data and product description, see data sheet on www.pepperl-fuchs.com



- **Sleek design, especially for storage and conveyor systems**
RL32-8-H-800-Ex2/47/73c
- **Adjustable background suppression**
RL32-8-H-800-Ex2/47/73c
- **Scratch-resistant and solvent resistant glass lens**
RL32-8-H-800-Ex2/47/73c
OCT300-M1K-N2
- **commonly used with glass fibre light guide, adapter type 18**
OCT300-M1K-N2



	Sensing range [mm]	Supply voltage [V DC]	Signal output	Ambient temperature [°C]	Protection degree	Connection type	Ex-identification	Figure	Wiring diagram
2 Wire, NAMUR									
OCT300-M1K-N2	0 ... 300	6 ... 20	NAMUR, N.O./N.C.	-25 ... 70	IP67	Terminal compartment	II 2G Ex op is ia IIC T6 II 1D Ex iaD 20 T 85°C	1	
MLV11-8-500-Ex/40b/112	0 ... 500	6 ... 20	NAMUR, N.O./N.C.	-25 ... 70	IP67	Connector M12 x 1, 4 pin	II 2G Ex op is ia IIC T6	2	
RL36-8-2000-Ex/40b/116	0 ... 2000	6 ... 20	NAMUR, N.O./N.C.	-25 ... 70	IP54	Terminal compartment	II 2G Ex op is ia IIC T4	3	
4 Wire, DC									
RL32-8-H-800-Ex2/47/73c	30 ... 800	10 ... 30	2 PNP, antivalent	-20 ... 50	IP65	Connector M12 x 1, 4 pin	II 3G Ex nA op is II T4 II 3D Ex tD A22 IP65 T 75°C	4	
RL32-8-H-800-RT-Ex2/47/73c	40 ... 800	10 ... 30	2 PNP, antivalent	-20 ... 50	IP65	Connector M12 x 1, 4 pin	II 3G Ex nA op is II T4 II 3D Ex tD A22 IP65 T 75°C	4	



Date of edition: 2009-08-27

For complete data and product description, see data sheet on www.pepperl-fuchs.com

Subject to modifications without notice

Pepperl+Fuchs Group
www.pepperl-fuchs.com

USA: +1 330 486 0001
fa-info@us.pepperl-fuchs.com

Germany: +49 621 776-4411
fa-info@pepperl-fuchs.com

Copyright Pepperl+Fuchs

Singapore: +65 6779 9091
fa-info@sg.pepperl-fuchs.com



- Resolution 14 mm (finger protection)
SLC14-750/133
- Resolution 30 mm (hand protection)
SLC30-1500/133
- Resolution 90 mm
SLC90-1800/133
- Protection degree IP66
- Terminal compartment with cable gland
- Start/Restart disable
- Further protection field height available (150 mm ... 1800 mm)

	Safety type acc. to IEC/EN 61496	Width of protected area [m]	Protection field height [mm]	Operation voltage [V DC]	Inputs	Outputs	Ambient temperature [°C]	Ex-identification	SIL, acc. to IEC 60508
SLC14-750/133	4	0,2 ... 5	750	24	Reset-input for system test Start release	2 fail safe semiconductor outputs. 2 PNP for start readiness and OSSD-condition	0 ... 55	II 3G Ex nA op is IIC T4 II 3D Ex tD A22 IP66 T 90°C	3
SLC30-1500/133	4	0,2 ... 15	1500	24	Reset-input for system test Start release	2 fail safe semiconductor outputs. 2 PNP for start readiness and OSSD-condition	0 ... 55	II 3G Ex nA op is IIC T4 II 3D Ex tD A22 IP66 T 90°C	3
SLC90-1800/133	4	0,2 ... 15	1800	24	Reset-input for system test Start release	2 fail safe semiconductor outputs. 2 PNP for start readiness and OSSD-condition	0 ... 55	II 3G Ex nA op is IIC T4 II 3D Ex tD A22 IP66 T 90°C	3

Elevator Light Grid for Zone 2 / Zone 22

AL2109-P-1820-Ex2/25/49/115

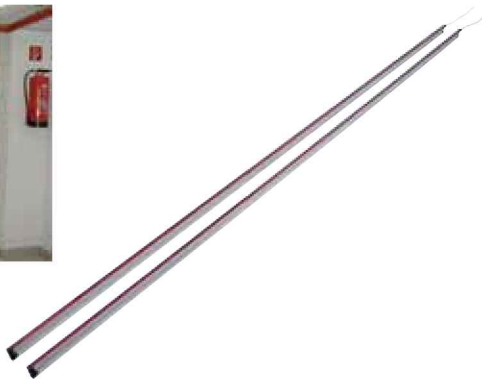

- ATEX approval for Zone 2 and Zone 22
- Object detection, even at distance zero
- Dense detection field with up to 135 beams
- Automatic beam crossing
- Automatic beam deflection
- Ambient light limit > 100.000 Lux
- In accordance with EN 81-70 and EN 12015/15
- Various possibilities for mounting

	Range [mm]	Field height [mm]	Number of beams	Connection type	Ex-identification
AL2109-P-1820-Ex2/25/49/115	0 ... 3500	1800 mm	61 ... 135 (dynamically)	5 m cable	II 3G Ex nA op is IIC T4 II 3D Ex tD A22 IP54 T 80°C

Wiring diagram

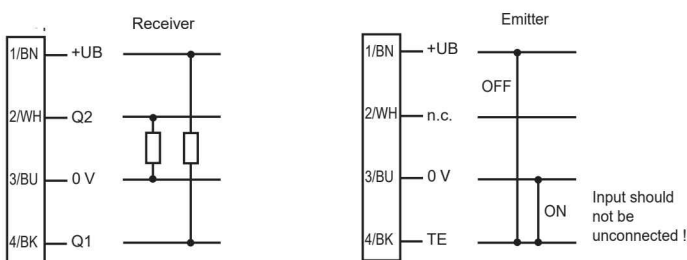

For complete data and product description, see data sheet on www.pepperl-fuchs.com

Date of edition: 2009-08-27

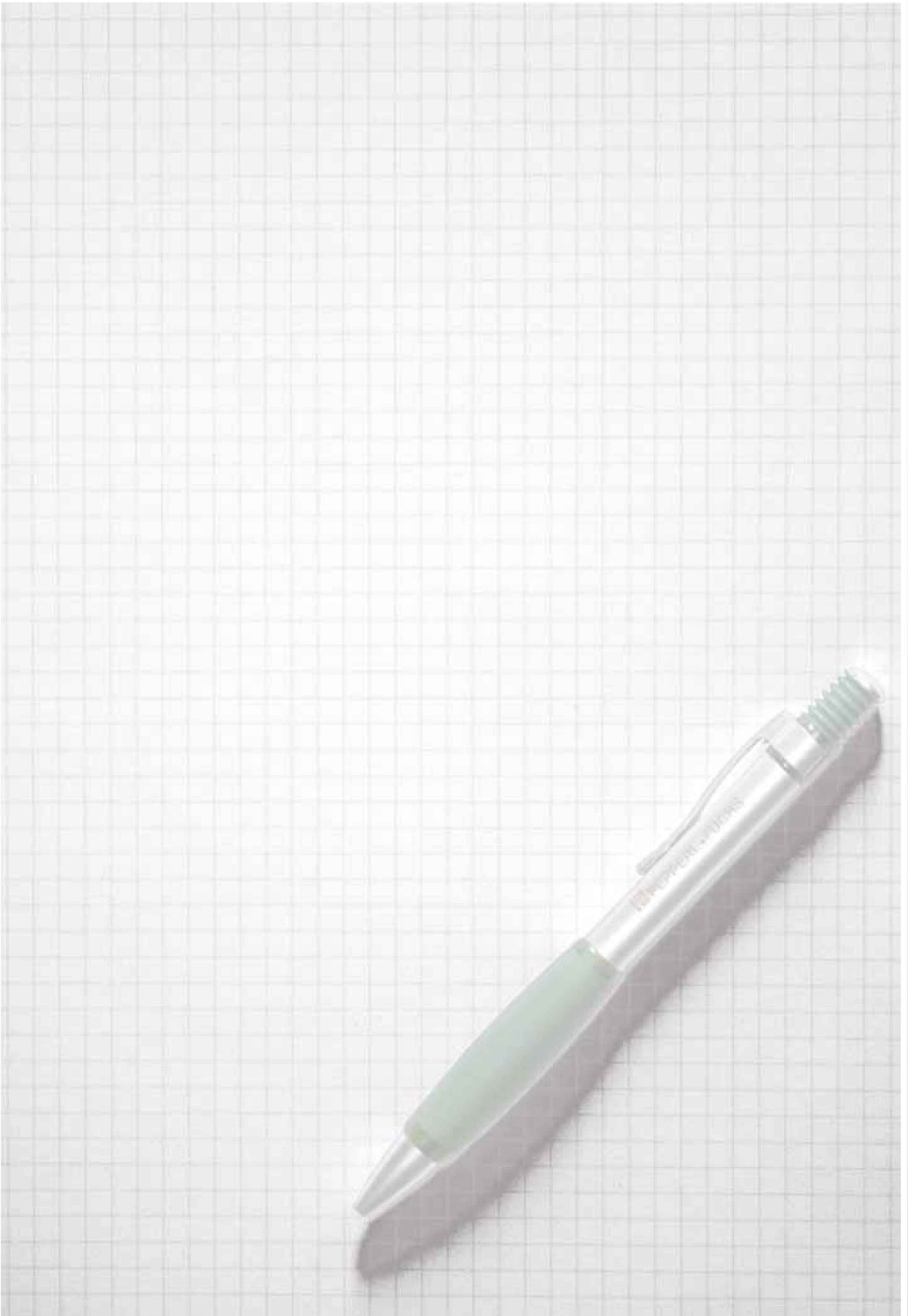

Date of edition: 2009-08-27

Subject to modifications without notice

Pepperl+Fuchs Group
www.pepperl-fuchs.com

USA: +1 330 486 0001
fa-info@us.pepperl-fuchs.com

Germany: +49 621 776-4411
fa-info@pepperl-fuchs.com

Copyright Pepperl+Fuchs
Singapore: +65 6779 9091
fa-info@sg.pepperl-fuchs.com

PEPPERL+FUCHS
SENSING YOUR NEEDS



Rotary Encoders

Rotary encoders are used for accurate position measurement and speed feedback. Due to their universal application, rotary encoders can be found in almost all applications in automation, as well as in machinery and plant construction. Let us help you select a rotary encoder for your application demands.



Function Principles at a Glance

1. Incremental Rotary Encoders

Incremental rotary encoders provide a defined number of pulses per shaft revolution. Measurement of the cycle duration and the number of pulses per unit of time provide the rotational speed. If the number of pulses from a reference point are measured, the numerical value represents a measure of the angle displaced and the distance covered around the path. Two-channel encoders – with a phase shift of 90° – provide the series connected electronics to determine the direction of rotation of the shaft and thereby also enable bi-directional positioning tasks. Threechannel incremental encoders provide a so-called null signal once per revolution.

2. Absolute Rotary Encoders

Absolute value rotary encoders output a uniquely coded numerical value at each shaft position. In particular in positioning tasks, absolute encoders are free of the electronics of the counting tasks, so that complicated and expensive input assemblies can be eliminated. In addition, no referencing movements are required when switching the machine on and following a power failure, since the current position value remains immediately available. New technologies, such as magnetic scanning, extend the application possibilities and complete the range of absolute rotary encoders.

On serial absolute rotary encoders the output data is output via standardized interfaces and in accordance with standardized protocols. Although in the past point-to-point connections with serial data transfer were frequently employed, today field-bus systems are increasing.

2.1 Singleturn Absolute Rotary Encoders

In case of singleturn encoder, a revolution of the encoder (360°) is divided up into a maximum of 65,536 measuring steps (16 Bit). After each complete revolution, the coding process starts at the initial value. The encoder electronics does not recognise how many revolutions have been carried out.

2.2 Multiturn Absolute Rotary Encoders

In this configuration, a gear has been integrated – in addition to the disc coded in the singleturn configuration. This gear has been geared down and coded in such a way that up to 16,384 revolutions (14 bit) can be picked up. Thus, the overall resolution amounts to 16 bit (singleturn resolution) plus 14 bit (speed), totalling 30 bit. On account of the high number of measuring this type of encoder can be used to divide very long linear distances into small measuring steps.

Rotary Encoders for Hazardous Areas

Pepperl+Fuchs offers rotary encoders with the ignition protection types "Intrinsic Safety" (Ex i), "Flame Proof Enclosure" (Ex d) and "Non Sparking" (Ex nA).

Ignition Protection Type Ex i

The rated values of voltage and current are kept at such low levels that the NAMUR encoders can be used in hazardous areas. The power limitation is realized by the assigned switching amplifier (see page 60).

Ignition Protection Type Ex d

Devices of ignition protection type EEx d are designed in a way that their housings are not damaged in case of an explosion of an explosive mixture inside the housing. Thus, a propagation of the explosion to the surrounding explosive atmosphere is prevented. These encoders can be operated in zone 1 / zone 21.

Ignition Protection Type Ex nA

These are category 3 devices. They are bound for zone 2 or zone 22 where is only little occurrence-chance of explosive mixtures. Typical electrical devices type II3G for zone 2 (gas) or II3D for zone 22 (dust) are rotary encoders with ignition protection type nA - "Non Sparking". The requirements for ignition protection type n meet widely the requirements of ignition protection type e, but for failure-free operation.

CUSTOMIZED ENCODER SOLUTIONS

Can't find a rotary encoder for your application among our standard products? The team at the Customer Solution Center of Pepperl+Fuchs GmbH will be pleased to help you match an encoder to your specification.

Please speak to our experts, so that we can help you develop a tailor-made solution for your specific application.

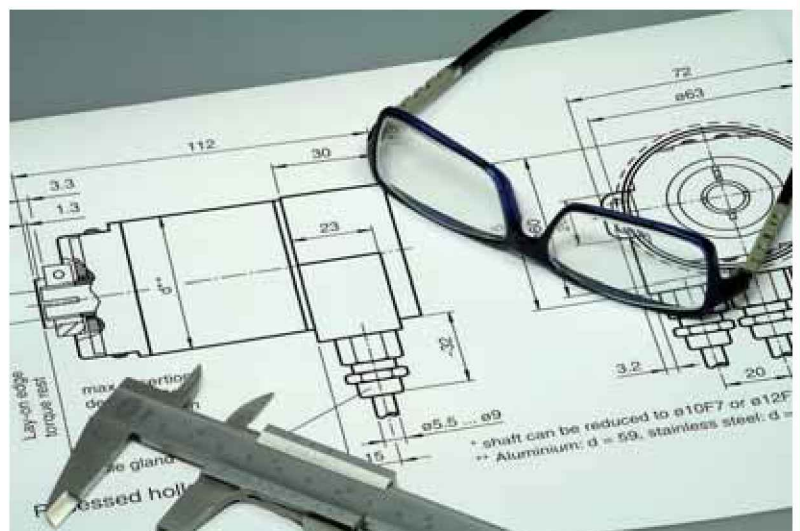

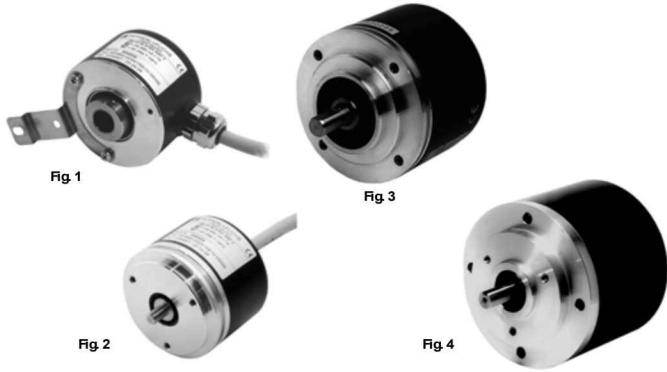

- Industrial standard housing
- ATEX approval
- Up to 5000 ppr
- Intrinsic safe
RVI84
- Flameproof enclosure
14-1436*
- Non-sparking
RVI58X-...
RSI58X-...

	Pulse count [max.]	Solid shaft	Recessed hollow shaft	Clamping flange	Servo flange	Output type	Connection type	Protection degree	Max. speed [min ⁻¹]	Ex-identification	Figure
2 Wire NAMUR											
RVI84	25	●		●	●	NAMUR	cable	IP65	3000	Ex II 2G Ex ia IIC T6	3
Push-pull outputs / RS 422 interface											
14-14361	5000	●		●	●	push-pull	cable	IP66	6000	Ex II 2G Ex d IIC T6 Ex II 2D Ex tD A21 IP66 T80°C	4
14-14366	5000	●		●	●	RS 422	cable	IP66	6000	Ex II 2G Ex d IIC T6 Ex II 2D Ex tD A21 IP66 T80°C	4
14-1436X	5000	●		●	●	RS 422	cable	IP66	6000	Ex II 2G Ex d IIC T6 Ex II 2D Ex tD A21 IP66 T80°C	4
RVI58X_*****1	5000	●		●	●	push-pull	cable	IP64	6000	Ex II 3G Ex nA IIB T4 Ex II 3D Ex tD A22 IP64 T105°C	2
RVI58X_*****6	5000	●		●	●	RS 422	cable	IP64	6000	Ex II 3G Ex nA IIB T4 Ex II 3D Ex tD A22 IP64 T105°C	2
RVI58X_*****X	5000	●		●	●	RS 422	cable	IP64	6000	Ex II 3G Ex nA IIB T4 Ex II 3D Ex tD A22 IP64 T105°C	2
RSI58X_*****1	5000		●			push-pull	cable	IP54	6000	Ex II 3G Ex nA IIB T4 Ex II 3D Ex tD A22 IP54 T105°C	1
RSI58X_*****6	5000		●			RS 422	cable	IP54	6000	Ex II 3G Ex nA IIB T4 Ex II 3D Ex tD A22 IP54 T105°C	1
RSI58X_*****X	5000		●			RS 422	cable	IP54	6000	Ex II 3G Ex nA IIB T4 Ex II 3D Ex tD A22 IP54 T105°C	1

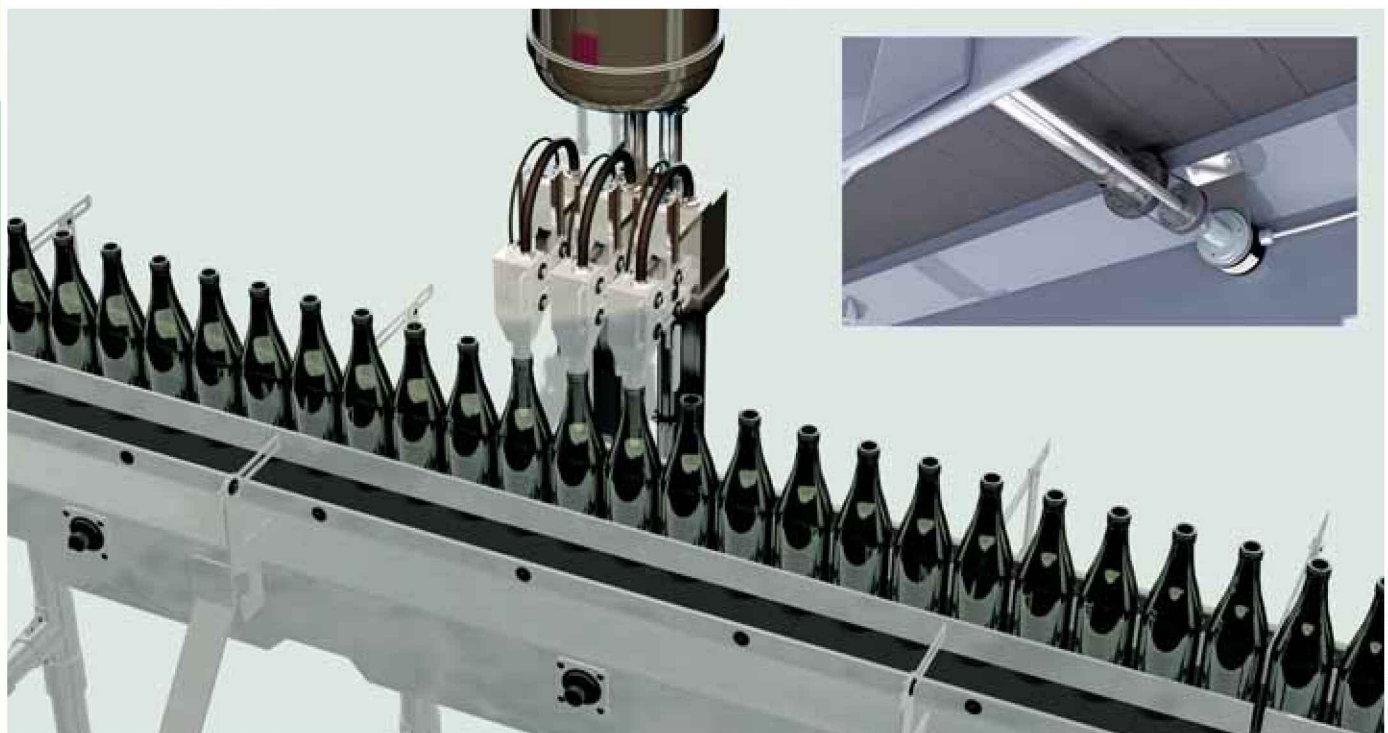

For complete data and product description, see data sheet on www.pepperl-fuchs.com

Date of edition: 2009-06-14

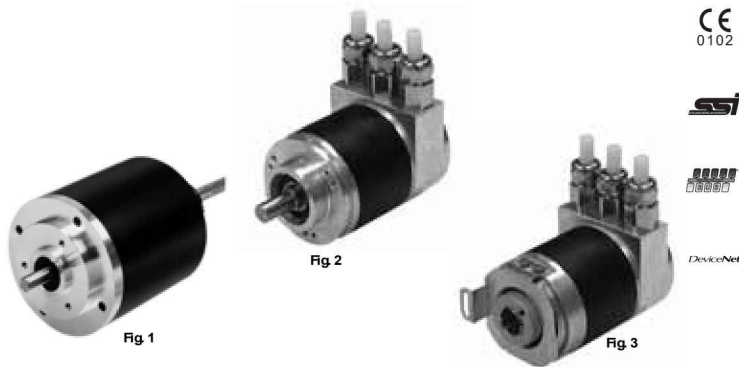

- Industrial standard housing
- Up to 16 Bit singleturn
- Up to 30 Bit multiturn
- Ex approval
- Programmable limit switches
- Max. speed 6000 min⁻¹

	Interface	Resolution singleturn [Bit]	Resolution multiturn [Bit]	Solid shaft	Recessed hollow shaft	Clamping flange	Servo flange	Connection type	Protection degree	Operation temperature [°C]	Gas Ex area [°C]	Dust Ex area [°C]	Max. speed [min ⁻¹]	Ex-identification	Figure
Protection type „Flameproof enclosure“															
AVS14	SSI	12	-	●	●	●	●	cable	IP66		-40 ... 55	-30 ... 55	6000	Ex II 2G Ex d IIC T6 Ex II 2D Ex TD A21 IP66 T80°C	1
AVM14	SSI	12	12	●	●	●	●	cable	IP66		-40 ... 55	-30 ... 55	6000	Ex II 2G Ex d IIC T6 Ex II 2D Ex TD A21 IP66 T80°C	1
PVS14	PROFIBUS	13	-	●	●	●	●	cable	IP66		-40 ... 55	-30 ... 55	6000	Ex II 2G Ex d IIC T6 Ex II 2D Ex TD A21 IP66 T80°C	1
PVM14	PROFIBUS	13	12	●	●	●	●	cable	IP66		-40 ... 55	-30 ... 55	6000	Ex II 2G Ex d IIC T6 Ex II 2D Ex TD A21 IP66 T80°C	1
CVM14	CANopen	13	12	●	●	●	●	cable	IP66		-40 ... 55	-30 ... 55	6000	Ex II 2G Ex d IIC T6 Ex II 2D Ex TD A21 IP66 T80°C	1
DVM14	DeviceNet	13	12	●	●	●	●	cable	IP66		-40 ... 55	-30 ... 55	6000	Ex II 2G Ex d IIC T6 Ex II 2D Ex TD A21 IP66 T80°C	1
Protection type „Non-sparking“															
PVS58X	PROFIBUS	up to 16	-	●	●	●	●	Terminal compartment	shaft side: IP64 /IP66 housing side: IP65	-30 ... 55	-	-	6000	Ex II 3G Ex nA IIB T4 Ex II 3D Ex tD A22 IP64 T120°C	2
PVM58X	PROFIBUS	up to 16	14	●	●	●	●	Terminal compartment	shaft side: IP64 /IP66 housing side: IP65	-30 ... 55	-	-	6000	Ex II 3G Ex nA IIB T4 Ex II 3D Ex tD A22 IP64 T120°C	2
PSM58X	PROFIBUS	up to 16	14	●	●	●	●	Terminal compartment	shaft side: IP64 /IP66 housing side: IP65	-30 ... 55	-	-	6000	Ex II 3G Ex nA IIB T4 Ex II 3D Ex tD A22 IP64 T120°C	3
PSS58X	PROFIBUS	up to 16	-	●	●	●	●	Terminal compartment	shaft side: IP64 /IP66 housing side: IP65	-30 ... 55	-	-	6000	Ex II 3G Ex nA IIB T4 Ex II 3D Ex tD A22 IP64 T120°C	3

AS-Interface

AS-Interface is the standard solution for simple, cost-effective networking of sensors and actuators in the field. In addition to expert application analysis and technical expertise, Pepperl+Fuchs provides a complete product family..



Masters and Gateways

- For PROFIBUS, Interbus, EtherNet/IP, ProfiNet, Modbus/TCP, DeviceNet, CANopen, CC-Link and serial connection
- With integrated PLC functionality
- For field and switching cabinet installation
- As a single or dual master (for two AS-Interface circuits)
- Graphical display with full text diagnostics
- Detects ground fault and duplicate addressing
- Integrated data decoupling available as option

Power supplies

- From 2 A to 8 A with overload protection
- With and without line fault detection

Slave modules

- For binary and analog signals
- For the connection of pneumatic valves
- For hazardous areas
- For indicator lamps
- Displays and controls

Safety Switch and Enabling Switch

- Door latching devices and door latching retention
- Enabling switch and emergency stop

AS-Interface at a Glance

- Topology free: easy to extend and modify
- Works with all fieldbuses
- Mechanically keyed flat cable guarantees correct polarity, utilizes redundant piercing connection technology
- High interference immunity
- Automatic single node replacements
- Comprehensive diagnostic functions and graphical LC display
- Power and communication on the same 2-conductor cable



AS-Interface - Safety at Work

AS-Interface Safety at Work technology has been tested by the TÜV and found to meet the requirements for safety categories up to and including Category 4 of EN 954-1 and has achieved certification for use in systems up to and including SIL3 (as in IEC 61508).

This is accomplished using AS-Interface and safety on only one flat cable. Cabling costs are minimized. The wiring between the Safety Monitor and the Safety Nodes is continually monitored. Any fault in the cabling is immediately detected. Software ASIMON is available to configure the Safety Monitor.

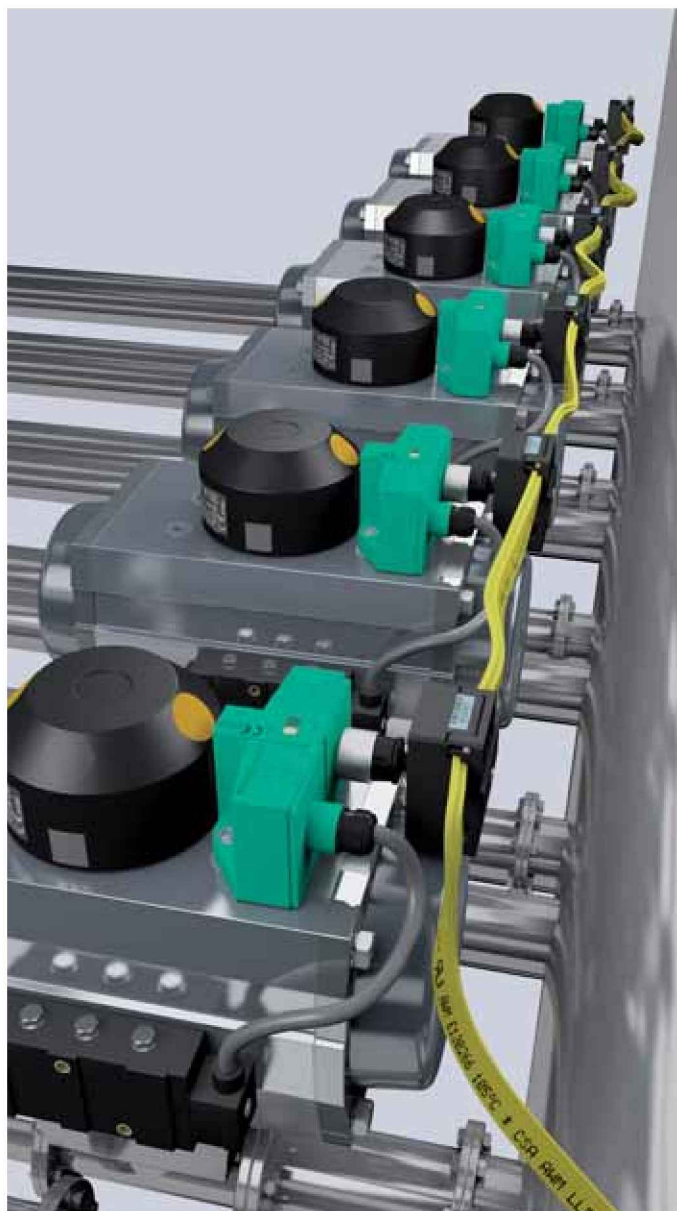



Fig. 1



Fig. 2



Fig. 3



Fig. 4



	Function	Supply voltage	Current loading capacity	Interface	Protection degree	Specification	Inputs	Outputs	UL approval	Figure
VAN-115/230AC-K17	Power supply	90 ... 265 V AC	4 A	-	IP20			1	●	1
VAN-115/230AC-K24	Power supply	115/230 V AC	8 A	-	IP20			1	●	2
VAN-G4-PE-4A	Power extender	30 V DC	4 A	-	IP67		1	1		3
VAN-KE2-2PE	Power extender	30 V DC	4 A	-	IP20			2		4



Fig. 1



Fig. 2



	Function	Supply voltage	Schnittstelle	Protection degree	Spezifikation	UL-Zulassung	Figure
VBG-DN-K20-D	AS-Interface Gateway	from AS-Interface	DeviceNet	IP20	V3.0	●	1
VBG-DN-K20-DMD	AS-Interface Gateway with integrated double master	from AS-Interface	DeviceNet	IP20	V3.0	●	1
VBG-PB-K20-D	AS-Interface Gateway	from AS-Interface	PROFIBUS DP	IP20	V3.0	●	2
VBG-PB-K20-DMD	AS-Interface Gateway with integrated double master	from AS-Interface	PROFIBUS DP	IP20	V3.0	●	2

Date of edition: 2009-08-27

For complete data and product description, see data sheet on www.pepperl-fuchs.com

Subject to modifications without notice

Pepperl+Fuchs Group
www.pepperl-fuchs.com

USA: +1 330 486 0001
fa-info@us.pepperl-fuchs.com

Germany: +49 621 776-4411
fa-info@pepperl-fuchs.com

Copyright Pepperl+Fuchs

Singapore: +65 6779 9091
fa-info@sg.pepperl-fuchs.com



Fig. 1



Fig. 2



Fig. 3



Fig. 4



Fig. 5



Fig. 6



Fig. 7



Function	Protection degree	Specification	Inputs	Outputs	UL approval	Figure	
VAA-4E2A-G5-N/V2-Ex	Ex module II (1GD) 2G Ex e mb [ia] IIB/IC T4	IP54	V2.0	4	2		1
VBA-2E2A-G12-ZAJ/EA2L	Digital I/O module	IP67	V3.0	2	2	●	2
VBA-4E4A-G12-ZAJ/EA2L	Digital I/O module	IP67	V3.0	4	4	●	3
VBA-4E4A-KE-ZE/E2	Digital I/O module	IP20	V3.0	4	4	●	4
VBA-4E-G12-ZAJ	Digital I/O module	IP67	V3.0	4		●	2
VBA-4E-KE-ZE	Digital I/O module	IP20	V2.1	4		●	4
VBA-2E-KE2-I/U-V3.0	Analog I/O module	IP20	V3.0	2			5
VBA-4E-G4-Pt100	Analog I/O module	IP65	V2.1	4			6
VBA-2A-KE2-I/U	Analog I/O module	IP20	V3.0		2	●	5
VBA-4E4A-CB1-ZEJ/E2J	Digitales I/O-Modul	IP20	V2.1	4	4	●	7

Pneumatic Modules



Fig. 1



Fig. 2



Fig. 3



Function	Protection degree	Specification	Inputs	Outputs	Air pressure [bar]	Possible external valve supply	CSA approval	Figure
VAA-4E2A-G1-ZE/PEXT-S	IP65	V2.0	2 x 2	2	2 ... 8	●	●	1
VAA-4E2A-G1-ZE/P-S	IP65	V2.0	2 x 2	2	2 ... 8		●	1
VBA-4E2A-G1-ZE/PEXT-S		V3.0	2 x 2	2	2 ... 8	●		2
VBA-4E2A-G1-ZE/P-S		V3.0	2 x 2	2	2 ... 8			3

For complete data and product description, see data sheet on www.pepperl-fuchs.com



Fig. 1



Fig. 2



Fig. 3

	Function	Connection	Protection degree	Current load capacity	Figure
VAZ-T1-FK-1M-PUR-V1-W	Splitter box	AS-Interface flat cable → M12 x 1, socket	IP67 / IP 68 / IP69K	max. 4 A	1
VAZ-T1-FK-V1R	Splitter box	AS-Interface flat cable → M12 x 1, socket	IP67 / IP 68 / IP69K	max. 4 A	2
VAZ-2FK-B3	Splitter box	AS-Interface flat cable → AS-Interface flat cable	IP67 / IP 68 / IP69K	max. 8 A	3

Miscellaneous



Fig. 1



Fig. 2



Fig. 3



Fig. 4



Fig. 5



Fig. 6



Fig. 7



	Function	Protection degree	Specification	UL approval	Figure
VBP-HH1-V3.0-V1	Handheld programming device	IP20	V3.0		1
VAR-KE3-TERM	Repeater	IP20	V3.0	●	2
VAZ-TERM	Terminal resistor	IP67	V2.11		3
VBA-LT2-G1	Indication/operation	IP67	V2.1		4
U-G1FFA	Base	IP67		●	5
VAZ-FK-R-YE ¹⁾	Cable, yellow			●	6
VAZ-FK-R-BK	Cable, black			●	7

¹⁾ The cable VAZ-FK-R-YE is bound to be used as indoors energy bus wire.

For complete data and product description, see data sheet on www.pepperl-fuchs.com

Subject to modifications without notice

Pepperl+Fuchs Group
www.pepperl-fuchs.com

USA: +1 330 486 0001
fa-info@us.pepperl-fuchs.com

Germany: +49 621 776-4411
fa-info@pepperl-fuchs.com

Copyright Pepperl+Fuchs
Singapore: +65 6779 9091
fa-info@sg.pepperl-fuchs.com

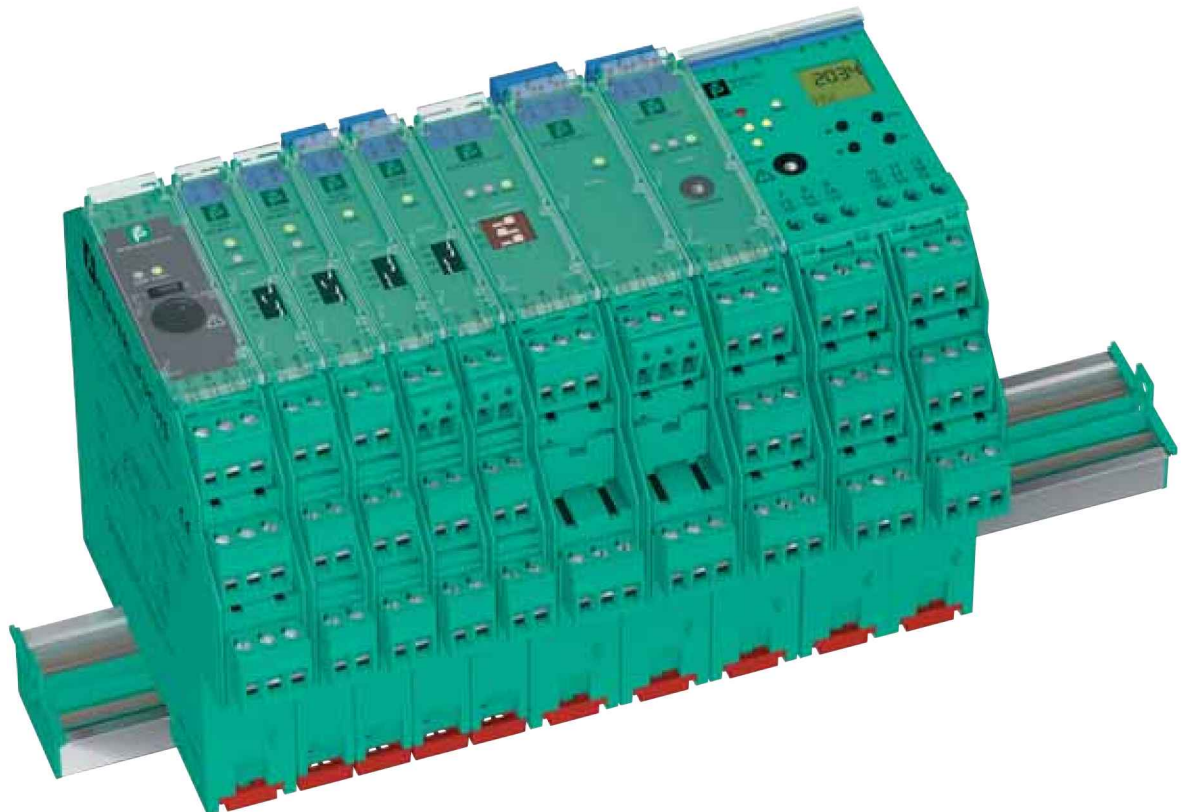

The K system is flexible: as you need it

Pepperl+Fuchs is the world's leading manufacturer of intrinsically safe isolated barriers. Our large selection of K-System isolator modules confirms this fact: the series consists of over 150 different modules.

The K system is easy to specify, integrate, and expand and is synonymous with safety and reliability.

The 12.5 mm wide KC modules have all the same proven features as the tried and tested 20 mm and 40 mm wide KF modules.

KF modules

- 20 mm housing
- Highest packing density with only 5 mm per channel
- Extensive product range of isolator modules
- 40 mm housing
- Logic control units determine and monitor the standstill, rotational speed and direction, slip, and flow amounts
- Analog signal converters monitor signals from transmitters, measuring bridges, and temperature sensors
- Configurable with PACTware or pushbuttons
- Wide range power supply



KC modules

- High signal integrity
- Compact housing: only 12.5 mm wide
- Only 0.8 W power requirement per module



International safety standards

SIL
IEC61508

- Standardized documentation: one set of models for all applications
- Global certification
- Replacement parts can be reduced to the minimum
- Proven technology and international support

SIL data is available for systems and processes without additional charge. In order to reduce safety risks, Pepper+Fuchs has integrated SIL levels into the standard K system offering.

2:1 technology: two signals on one line



In the process automation sector, digital signals are mainly transmitted via inductive sensors. Intrinsically safe sensors are specifically designed for use in hazardous areas. The specifications of these sensors comply with the EN 60947-5-6 standard and they are also called NAMUR sensors. The sensor supply and the status information are transmitted simultaneously on the 2-wire connection.

With conventional field wiring, each sensor is connected to the associated switch amplifier via its own 2-wire cable. With 2:1 technology, the signals from two NAMUR-compliant sensors can be transmitted to the control cabinet by the same stranded pair.

This patented evaluation system from Pepperl+Fuchs is simple but effective. Both 2-wire sensors have an integrated reverse polarity protection function and have an antiparallel wire connection to a cable pair. The special evaluation electronics of the connected Pepperl+Fuchs control device in 2:1 technology differentiate between the signals on the basis of their polarity and divide them into two separate channels which are sent to the output to enable the signals to be processed.

Due to the high switching speed between the two channels, more exacting demands are placed on the time response of the sensor. Compatible sensors are marked in the data section of this catalog.

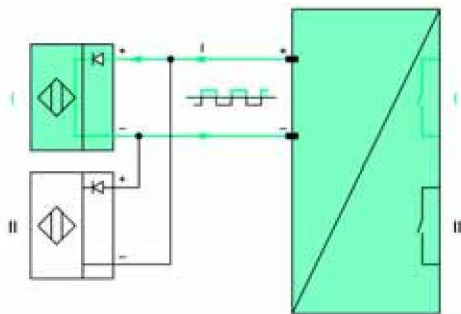

Sensor I is active

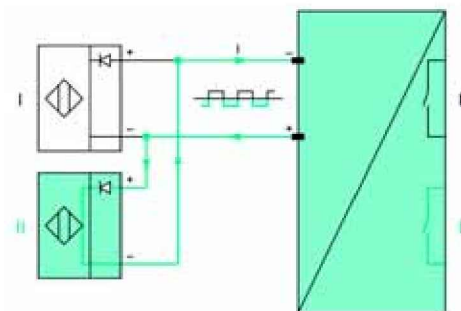

Sensor II is active

The 2:1 technology is of particular advantage in situations where digital signals occur in pairs on one measuring point, e.g. for position monitoring with poppet valves and rotary drives or trip amplifiers for min./ max. positions on dials.

A synergy is created with the combination of dual sensors and Pepperl+Fuchs technology. One sensor and one cable supply two signals.

For system enhancements, additional signals can use the existing wiring via the 2:1 transmission technology.



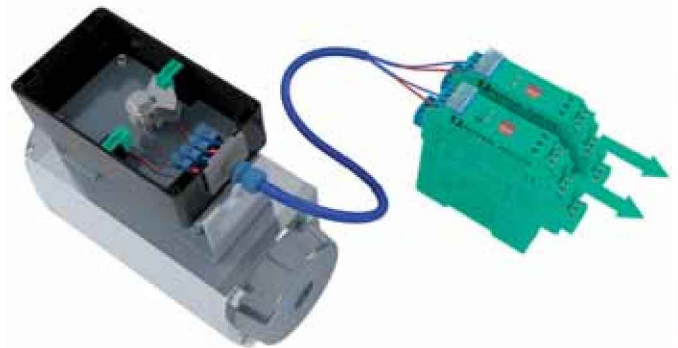



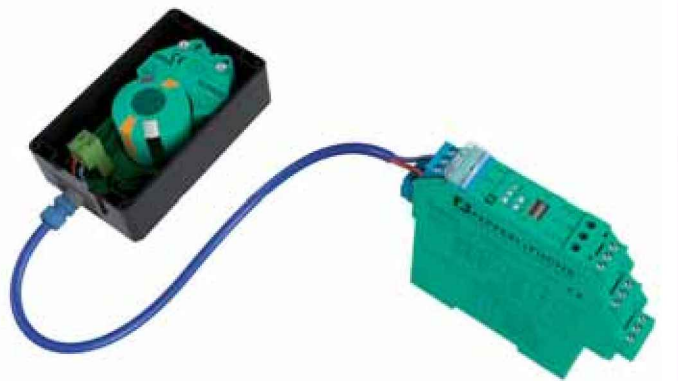







The required installation time and space within the control cabinet are also reduced significantly. First, only half the number of terminals has to be connected and second, an ideal packing density can be achieved due to four-channel switch amplifiers in the terminal housing, which is only 20 mm wide. The cables are monitored for short circuits and lead breakages in the usual way. When servicing, correct functioning can be checked using any multimeter and a series diode.









Classic wiring with 2 isolated NAMUR circuits and 2 switch amplifiers



2:1 technology in combination with a dual sensor









Switch Amplifiers							
	Device function	Number of channels	Input (field side)	Output (control side)	Operating voltage/ Fieldbus interface	Ex-identification	SIL, acc. to IEC 61508
KCD2-SR-Ex1.LB	Switch amplifier	1	NAMUR sensor	2 relay	19 ... 30 V DC	 II (1)GD [Ex ia] IIC; [Ex ia D] I (M1) [Ex ia] I  II 3G Ex nA nC IIC T4 X	2
KCD2-SR-Ex2	Switch amplifier	2	NAMUR sensor	2 relay	19 ... 30 V DC	 II (1)GD [Ex ia] IIC; [Ex ia D] I (M1) [Ex ia] I  II 3G Ex nA nC IIC T4 X	2
KFA6-SR2-Ex2.W	Switch amplifier	2	NAMUR sensor	2 relay	207 ... 253 V AC	 II (1)GD [Ex ia] IIC	2
KFD2-ST2-Ex2	Switch amplifier	2	NAMUR sensor	2 transistor	20 ... 30 V DC	 II (1)GD [Ex ia] IIC  II 3G Ex nA II T4	2
KFD2-SOT2-Ex2	Switch amplifier	2	NAMUR sensor	2 transistor	20 ... 30 V DC	 II (1)GD [Ex ia] IIC  II 3G Ex nA II T4	2
KFA6-SOT2-Ex2	Switch amplifier	2	NAMUR sensor	2 transistor	207 ... 253 V AC	 II (1)G [Ex ia] IIC  II (1)D [Ex iaD]	2
KFD2-SOT2-Ex1.N	Switch amplifier	1	NAMUR sensor	NAMUR	20 ... 30 V DC	 II (1)GD [Ex ia] IIC  II 3G Ex nA II T4 X	2























Switch Amplifiers in 2:1 Technology							
 	Device function	Number of channels	Input (field side)	Output (control side)	Operating voltage/ Fieldbus interface	Ex-identification	SIL, acc. to IEC 61508
KFD2-SRA-Ex4	Switch amplifier	4	NAMUR sensor	4 relay	19 ... 30 V DC	 II (1)GD [Ex ia] IIC	

Safety Switch Amplifiers							
	Device function	Number of channels	Input (field side)	Output (control side)	Operating voltage/ Fieldbus interface	Ex-identification	SIL, acc. to IEC 61508
KFD2-SH-Ex1	Safety switch amplifier	1	NAMUR sensor	2 relay	20 ... 35 V DC	 II (1)GD [Ex ia] IIC  II 3G Ex nAC IIC T4	3
KHA6-SH-Ex1	Safety switch amplifier	1	NAMUR sensor	2 relay	85 ... 253 V AC	 II (1)GD [Ex ia] IIC	3

Switch Amplifiers for Safe Areas							
	Device function	Number of channels	Input (field side)	Output (control side)	Operating voltage/ Fieldbus interface	Ex-identification	SIL, acc. to IEC 61508
KCD2-SR-1.LB	Switch amplifier	1	NAMUR sensor	2 relay	19 ... 30 V DC	-	2
KCD2-SR-2	Switch amplifier	2	NAMUR sensor	2 relay	19 ... 30 V DC	-	2

For complete data and product description, see data sheet on www.pepperl-fuchs.com

Speed Monitors / Frequency Converters								
	Device function	Number of channels	Input (field side)	Output (control side)	Operating voltage/ Fieldbus interface	Ex-identification	SIL, acc. to IEC 61508	
	KFD2-DWB-Ex1.D	Speed monitor	1	-	Relay	20 ... 30 V DC	 II (1)GD [Ex ia] IIC  II 3G Ex nA nC IIC T4	2
	KFA6-DWB-Ex1.D	Speed monitor	1	-	Relay	230 V AC	 II (1)GD [Ex ia] IIC	2
	KFD2-SR2-Ex2.W.SM	Standstill monitor	1	NAMUR sensor	Relay	20 ... 30 V DC	 II (1)GD [EEx ia] IIC  II (3)G (EEx nL) IIC T4  II 3G EEx nAC IIC T4	2
	KFU8-UFC-Ex1.D	Frequency converter	1	Speed / Frequency	Relay + analog	20 ... 90 V DC / 48 ... 253 V AC	 II (1)GD [Ex ia] IIC	2
	KFU8-UFT-Ex2.D	Frequency converter	2	-	Relay + analog	20 ... 90 V DC / 48 ... 253 V AC	 II (1)GD [Ex ia] IIC	

Solenoid Drivers								
	Device function	Number of channels	Input (field side)	Output (control side)	Operating voltage/ Fieldbus interface	Ex-identification	SIL, acc. to IEC 61508	
	KFD0-SD2-Ex1.1065	Solenoid driver	1	-	-	loop powered	 II (1)GD [Ex ia] IIC	3
	KFD0-SD2-Ex1.1180	Solenoid driver	1	-	-	loop powered	 II (1)GD [Ex ia] IIB	3
	KFD0-SD2-Ex1.1045	Solenoid driver	1	-	-	loop powered	 II (1)GD [Ex ia] IIC	3
	KFD0-SD2-Ex2.1045	Solenoid driver	2	-	-	loop powered	 II (1)GD [Ex ia] IIC  II 3G Ex nA II T4	3
	KCD0-SD-Ex1.1245	Solenoid driver	1	-	-	-	 II (1)GD [Ex ia] IIC; [Ex ia D]  I (M1) [Ex ia] I  II 3G Ex nA II T4 X	3
	KFD0-SD2-Ex2.1245	Solenoid driver	2	-	-	loop powered	 II (1)GD [Ex ia] IIC	3
	KFD0-SD2-Ex1.10100	Solenoid driver	1	-	-	loop powered	 II (1)GD [Ex ia] IIC	3
	KFD2-SL2-Ex1	Solenoid driver	1	with pre-logic	-	20 ... 30 V DC	 II (1)GD [Ex ia] IIC; [Ex ia D]  II 3G Ex nA II T4 X	2
	KFD2-SL2-Ex1.B	Solenoid driver	1	with pre-logic	-	20 ... 30 V DC	 II (1)GD [Ex ia] IIC; [Ex ia D]  II 3G Ex nA II T4 X	2
	KFD2-SL2-Ex1.LK	Solenoid driver	1	with pre-logic	-	19 ... 30 V DC	 II (1)GD [Ex ia] IIC; [Ex ia D]  II 3G Ex nA nC IIC T4 X	2
	KFD2-VM-Ex1.35	Solenoid driver	1	with pre-logic	-	20 ... 30 V DC	 II (1)GD [Ex ia] IIC	
	KFD2-VM-Ex1.35.L	Solenoid driver	1	with pre-logic	-	20 ... 30 V DC	 II (1)GD [Ex ia] IIC	
	KFD2-SL2-Ex2	Solenoid driver	2	with pre-logic	-	20 ... 30 V DC	 II (1)GD [Ex ia] IIC; [Ex ia D]  II 3G Ex nA II T4 X	2
	KFD2-SL2-Ex2.B	Solenoid driver	2	with pre-logic	-	20 ... 30 V DC	 II (1)GD [Ex ia] IIC; [Ex ia D]  II 3G Ex nA II T4 X	2

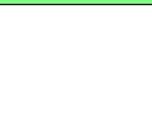
Speed Monitors for Safe Areas								
	Device function	Number of channels	Input (field side)	Output (control side)	Operating voltage/ Fieldbus interface	Ex-identification	SIL, acc. to IEC 61508	
	KFU8-DWB-1.D	Speed monitor	1	NAMUR sensor	Relay	20 ... 90 V DC / 48 ... 253 V AC		2
	KFD2-SR2-2.W.SM	Standstill monitor	1	NAMUR sensor	Relay	20 ... 30 V DC		2

For complete data and product description, see data sheet on www.pepperl-fuchs.com

Date of edition: 2009-08-28

Subject to modifications without notice

Pepperl+Fuchs Group
www.pepperl-fuchs.com

USA: +1 330 486 0001
fa-info@us.pepperl-fuchs.com

Germany: +49 621 776-4411
fa-info@pepperl-fuchs.com

Copyright Pepperl+Fuchs

Singapore: +65 6779 9091
fa-info@sg.pepperl-fuchs.com



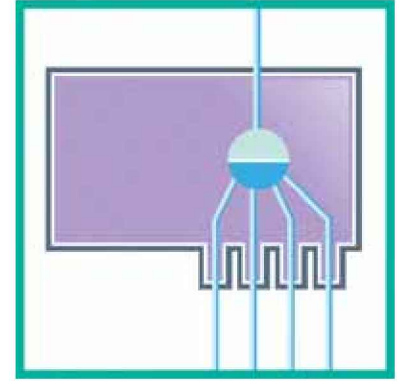

Efficient data exchange with field devices is an important requirement for every field bus infrastructure. Proximity switches, safety cut-off valves, digital inputs, low power valves and other devices on process interfaces are associated with the fieldbus. Several conventional signals are transmitted via a process interface, and thus connected via a field bus address. The integration into the DCS is using EDDL or FDT / DTM technology.

Due to the ability of the field bus, to transfer energy and communication on a two-wire cable process interfaces are particularly in hazardous areas a cost effective solution. They can be installed close to sensors in zone 1/class I, Div. 2. The sensors themselves can be attached in zone 0 / class I, Div. 1.

The valve coupler connects up to four low power valves and position indicators with a single fieldbus address. Additional features provide for minimal effort in the configuration and maintenance. The Ventilanschaltung reports the break-away and the runtime of each valve. Information is available for asset management systems instantly.



- Power supply and control via fieldbus cable
- Up to four valves via a single bus address
- Electrical isolation between fieldbus and valves
- Integrated monitoring of end positions by means of two sensors
- Integrated partial stroke test and other software functions
- Lead breakage monitoring and short-circuit monitoring for each individual conventional signal cable

	Field bus	Number of channels	Input	Output	Ex-identification	
FD0-VC-Ex4.FF	Foundation Fieldbus	8	8 sensors	4 valves	 II (1)2G Ex ia IIC T4	
FD0-VC-Ex4.PA	PROFIBUS PA	8	8 sensors	4 valves	 II (1)2G Ex ia IIC T4	



Date of edition: 2009-08-28

For complete data and product description, see data sheet on www.pepperl-fuchs.com

Slot type sensors

Model number	Slot width [mm]
SJ2-S1N	2
SJ2-SN	2
SC2-N0	2
SJ2-N	2
SJ3,5-N-LED	3,5
SJ3,5-S1N	3,5
SJ3,5-SN	3,5
SC3,5-G-N0	3,5
SC3,5-N0-BU	3,5
SC3,5-N0-YE	3,5
SC3,5-N0-GN	3,5
SJ3,5-G-N	3,5
SJ3,5-N-BU	3,5
SJ3,5-N-YE	3,5
SJ3,5-N-GN	3,5
SC3,5-N0-WH	3,5

Ring type sensors

Model number	Ring width [mm]
RC10-14-N0	10

Sensors for valve positioners (dual sensors)

Model number	Series
NCN3-F25F-N4-V1	-F25
NCN3-F25-N4-5M	-F25
NCN3-F25-N4-0,14	-F25
NCN3-F25-N4-K1V1	-F25
NCN3-F25-N4-V1	-F25
NCN3-F31-N4-V1	-F31
NCN3-F31-N4-V16-V16	-F31
NCN3-F31-N4-K	-F31
NCN3-F31-N4-K-K	-F31
NCN3-F31-N4-V18	-F31
NCN3-F31-N4-V16-K	-F31
NCN3-F31-N4-V16-V1	-F31
NCN3-F31-N5-V18-V1	-F31
NCN3-F31K-N4	-F31K
NCN3-F31K-N4-K	-F31K
NCN3-F31K-N4-V1-V1	-F31K
PL3-F25-N4-K	Printed circuit board
PL2-F25-N4-K	Printed circuit board
PL2-F25-N5-K	Printed circuit board
PL2-F25-N5-S	Printed circuit board
PL3-F25-N5-K	Printed circuit board
PL3-F25-N5-S	Printed circuit board
PL4-F25-N4-K	Printed circuit board
PL3-F25-SN4-K	Printed circuit board
PL2-F25-SN4-K	Printed circuit board

Cylindrical sensors

Model number	Series (diameter)
NJ0,8-4,5-N	4.5 mm, metal
NJ0,8-5GM-N	M5, metal
NJ1,5-6,5-N	6.5 mm, metal
NJ1,5-6,5-N-5M	6.5 mm, metal
NCB1,5-6,5M25-N0-V1	6.5 mm, metal
NCB1,5-6,5M25-N0	6.5 mm, metal
NJ1,5-8GM-N	M8, metal
NJ1,5-8GM-N-V1	M8, metal
NCB1,5-8GM25-N0-V1	M8, metal
NCB1,5-8GM25-N0	M8, metal
NJ2-11-SN	11 mm, plastic
NJ5-11-N	11 mm, plastic
NJ2-12GK-SN	M12, plastic
NJ2-12GK-N	M12, plastic
NJ2-12GM-N	M12, metal
NJ2-12GM-N-V1	M12, metal
NCB4-12GM40-N0	M12, metal
NCB4-12GM40-N0-V1	M12, metal
NJ2-11-SN-G	M14, metal
NJ2-11-SN-G-10M	M14, metal
NJ2-11-SN-G-5M	M14, metal
NJ5-11-N-G	M14, metal
NJ5-11-N-G-10M	M14, metal
NJ5-11-N-G-5M	M14, metal
NJ5-11-N-G-6M	M14, metal
NJ3-18GK-S1N	M18, plastic
NCB8-18GM40-N0	M18, metal
NCB8-18GM40-N0-V1	M18, metal
NJ6-22-SN-G	PG21, metal
NJ6-22-SN-G-10M	PG21, metal
NJ6-22-SN-G-3M	PG21, metal
NJ5-30GK-S1N	M30, plastic
NJ5-30GK-S1N-10M	M30, plastic
NJ5-30GK-S1N-5M	M30, plastic
NCB10-30GM40-N0	M30, metal
NCB10-30GM40-N0-15M	M30, metal
NCB10-30GM40-N0-5M	M30, metal
NCB10-30GM40-N0-10M	M30, metal
NCB10-30GM40-N0-V1	M30, metal

Cubical sensors

Model number	Series
NJ2-V3-N	-V3
NJ2-V3-N-V5	-V3

More sensors and detailed information on 2:1-Technology you will find at the data sheet of the switching amplifier KFD2-SRA-Ex4. This is available in multiple languages on the Internet at www.pepperl-fuchs.com as a pdf document for download. Simply write **KFD2-SRA-Ex4** in the product search mask.

Electrical connection accessories

Suitable accessories for both mounting and electrical connection of the sensors provide an enormous economic potential. Not only do you save a great deal of time and work during commissioning, but also when replacing and servicing the sensors. If harsh external environmental conditions prevail, appropriate Pepperl+Fuchs accessories can extend the service life of the products used.

1. Plug protector for use in Zone 2/Zone 22

V1 clip The V1 clip mechanical lock protects an M12 connector from loosening without tools. This reliably prevents accidental loosening of current-bearing cables from connected apparatus and the associated risk of incendive spark formation.



2. Field attachable connectors

M12 models

Order code	Design	Connection technology	Number of pins	Core cross-section [mm ²]	
V1-G	Socket, straight	Screw terminal technology PG7 cable gland	4-pin	max. 0.75	
V1-W	Socket, angled	Screw terminal technology PG7 cable gland	4-pin	max. 0.75	
V1S-G	Plug, straight	Screw terminal technology PG7 cable gland	4-pin	max. 0.75	
V1S-W	Plug, angled	Screw terminal technology PG7 cable gland	4-pin	max. 0.75	
V15-G-PG9	Socket, straight	Screw terminal technology	5-pin	max. 0.75	
V15-W-PG9	Socket, angled	Screw terminal technology	5-pin	max. 0.75	

Rd 24 x 1/8 models



Order code	Design	Connection technology	Number of pins	Core cross-section [mm ²]	
V16-G	Socket, straight	Screw terminal technology	6-pin + ground	max. 0.75	
V16-W	Socket, angled	Screw terminal technology	6-pin + ground	max. 0.75	
V16S-G	Plug, straight	Screw terminal technology	6-pin + ground	max. 0.75	

M18 models

Order code	Design	Connection technology	Number of pins	Core cross-section [mm ²]	
V18-G	Socket, straight	Screw terminal technology	4-pin	max. 1.5	
V18-W	Socket, angled	Screw terminal technology	4-pin	max. 1.5	

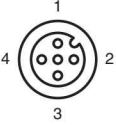
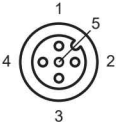

3. Cable connectors for DC sensors

M12 x 1 models, standard



Suitable for DC sensors in 2, 3, and 4 wire technology						
Cable sheath	Length [m]	Number of wires	ø [mm]	Pin assignment	Design straight	Design angled
PUR, gray	2	4	0.34		V1-G-2M-PUR	V1-W-2M-PUR
	5	4	0.34		V1-G-5M-PUR	V1-W-5M-PUR
	10	4	0.34		V1-G-10M-PUR	V1-W-10M-PUR
PUR, gray	2	5	0.34		V15-G-2M-PUR	V15-W-2M-PUR
	5	5	0.34		V15-G-5M-PUR	V15-W-5M-PUR
	10	5	0.34		V15-G-10M-PUR	V15-W-10M-PUR

PVC cables also available. Other lengths available on request

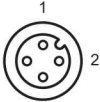
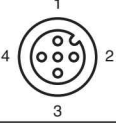
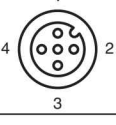

M12 x 1 models, for NAMUR sensors

Suitable for NAMUR sensors Molded head and cable sheath in blue						
Cable sheath	Length [m]	Number of wires	ø [mm]	Pin assignment	Design straight	Design angled
PVC, blue	2	2	0.34		V1-G-N-2M-PVC	V1-W-N-2M-PVC
	5	2	0.34		V1-G-N-5M-PVC	V1-W-N-5M-PVC
	10	2	0.34		V1-G-N-10M-PVC	V1-W-N-10M-PVC
PVC, blue	2	4	0.34		V1-G-N-4-2M-PVC	V1-W-N-4-2M-PVC
	5	4	0.34		V1-G-N-4-5M-PVC	V1-W-N-4-5M-PVC
	10	4	0.34		V1-G-N-4-10M-PVC	V1-W-N-4-10M-PVC
PUR, blue	2	4	0.34		V1-G-N-4-2M-PUR	V1-W-N-4-2M-PUR
	5	4	0.34		V1-G-N-4-5M-PUR	V1-W-N-4-5M-PUR
	10	4	0.34		V1-G-N-4-10M-PUR	V1-W-N-4-10M-PUR

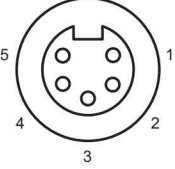

Rd 24 x 1/8 models for NAMUR sensors

Suitable for NAMUR sensors Cable sheath in blue						
Cable sheath	Length [m]	Number of wires	ø [mm]	Pin assignment	Design straight	Design angled
PVC, blue	5	4	0.34		V16-G-N-4-5M-PVC	V16-W-N-4-5M-PVC
	10	4	0.34		V16-G-N-4-10M-PVC	V16-W-N-4-10M-PVC
	15	4	0.34		V16-G-N-4-15M-PVC	V16-W-N-4-15M-PVC
	20	4	0.34		V16-G-N-4-20M-PVC	V16-W-N-4-20M-PVC

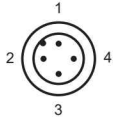
4. Cable connector in M12 x 1 model, standard

Suitable for DC sensors in 2, 3, and 4 wire technology						
Cable sheath	Length [m]	Number of wires	∅ [mm]	Pin assignment	Design straight	Design angled
PVC, gray	2	4	0.34		V1S-G-2M-PVC	V1S-W-2M-PVC

5. Cable connector in M12 x 1 model, for NAMUR sensors

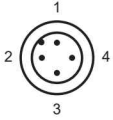
Suitable for NAMUR sensors Molded head and cable sheath in blue						
Cable sheath	Length [m]	Number of wires	∅ [mm]	Pin assignment	Design straight	Design angled
PVC, blue	0.5	4	0.34		V1S-G-N4-0,5M-PVC	V1S-W-N4-0,5M-PVC

Cable connectors are also available with green molded head and gray cable for standard sensors.

6. Junction Blocks

Junction blocks offer a cost-effective, space-saving, fast, and variable option for the installation of many initiators or actuators in the narrowest space to degree of protection IP67. You have the choice between versions with trunk cable, cage clamp plug-in connection, and M23 plug-in connection with 4 or 8 M12 slots. All types are suitable for pnp sensors/actuators. The double allocation types permit connection of 2 initiators or actuators in one M12 slot.

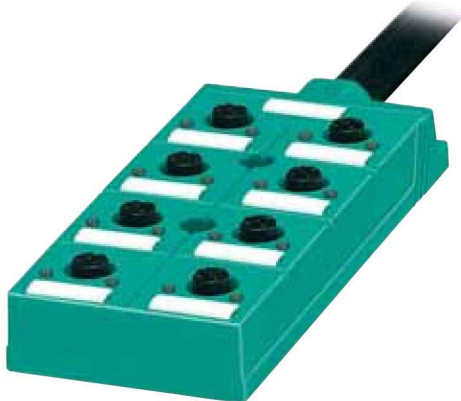
<ul style="list-style-type: none"> ■ Sensor-actuator-box with trunk cable, single allocation ■ with switching state displays ■ Dimensions (L x B x H) in mm 82 x 54 x 18.5 (4-way) 126.5 x 54 x 18.5 (8-way) 		
Cable length	Cable sheath	
5 m	PUR	
10 m	PUR	

7. Valve connectors

Valve connectors of types VMA, VMB and VMC are manufactured according to DIN EN 175301-803 (replaces DIN 43650). We also offer models VMBI (similar to VMB) and VMCI (similar to VMC). These valve connectors comply with the widespread industry design with contact gaps deviating from the standard design.

The sensor is connected with the valve connectors listed here as plug M12 x 1, angled, or field attachable. Straight connector versions are also available.



Variety

The flexibility in making the best solution for your application is evident from the variety of possible combinations. To make your selection and order as simple as possible, the following is a detailed explanation of our type code for valve connectors.

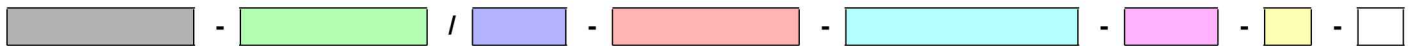
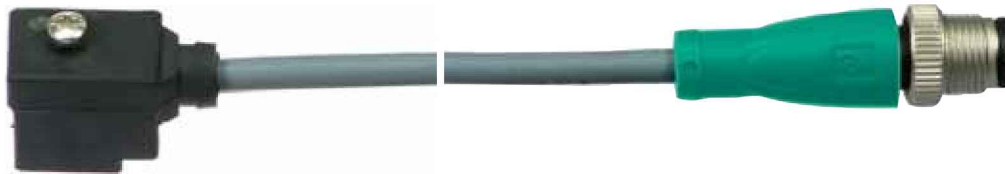

Valve connectors	
VMA	A models(DIN)
VMB	B models(DIN)
VMBI	B models (industry)
VMC	C models(DIN)
VMCI	C models(industry)

Number of pins	
2	2-pin
2+P	2-pin + ground (bridged)
3+P	3-pin + ground
...R	Connection diagram turned 180°

Wiring	
Blank	Not connected
L1	LED yellow (yellow/green for pressure switches)
Z2	with Z diode and yellow LED
S2	with suppressor diode and yellow LED
V2	with varistor and yellow LED
Other wiring available on request	

Cable length	
0.2 m - 30m	

Cable type	
PVC	2-/3-/4-pin, 0.34/0.5 mm²
PUR	2-/3-/4-pin, 0.34/0.5 mm² , halogen-free
PUR-S	halogen-free, welding bead resistant, 0.34 mm ²

Connection, sensor side	
V1	Plug M12 x 1, 4-pin
Blank	open cable end

Design	
G	straight
W	angled

Special model	
Y	

Example: VMA-2+P/Z2-5M-PUR-V1-G

A models
 2-pin + ground
 with Z diode and yellow LED
 5 m cable length
 PUR cable, 3-/5-pin, 0.34 mm², halogen-free
 M12 plug, 4 pin
 straight design

Order code	With surge protection diode and LED	Cable length	Version, valve side
------------	-------------------------------------	--------------	---------------------

A models

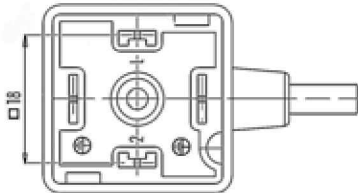
VMA-2+P-0,3M-PVC-V1-W		0.3 m	 <p>ground bridged</p>
VMA-2+P/Z2-0,3M-PVC-V1-W	●	0.3 m	
VMA-2+P-0,6M-PVC-V1-W		0.6 m	
VMA-2+P/Z2-0,6M-PVC-V1-W	●	0.6 m	
VMA-2+P/Z2-0,3M-PVC-V1-W-Y213510 ²⁾	●	0.3 m	
VMA-2+PE		field attachable	

B models

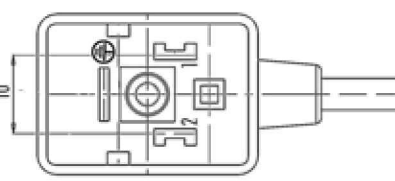
VMB-2+P-0,3M-PVC-V1-W		0.3 m	
VMB-2+P/Z2-0,3M-PVC-V1-W	●	0.3 m	
VMB-2+P-0,6M-PVC-V1-W		0.6 m	
VMB-2+P/Z2-0,6M-PVC-V1-W	●	0.6 m	
VMB-2+P/Z2-0,3M-PVC-V1-W-Y213511 ²⁾	●	0.3 m	
VMB-2+PE		field attachable	

BI models

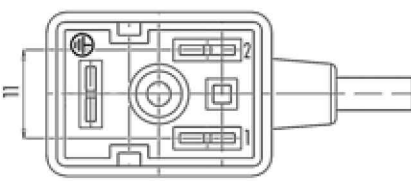
VMBI-2+P-0,3M-PVC-V1-W		0.3 m	
VMBI-2+P/Z2-0,3M-PVC-V1-W	●	0.3 m	
VMBI-2+P-0,6M-PVC-V1-W		0.6 m	
VMBI-2+P/Z2-0,6M-PVC-V1-W	●	0.6 m	
VMBI-2+P/Z2-0,3M-PVC-V1-W-Y ²⁾	●	0.3 m	
VMBI-2+PE		field attachable	

C models

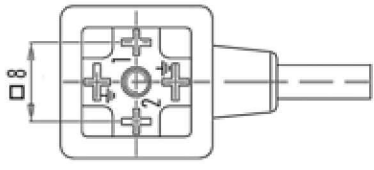
VMC-2+P-0,3M-PVC-V1-W		0.3 m	 <p>ground bridged</p>
VMC-2+P/Z2-0,3M-PVC-V1-W	●	0.3 m	
VMC-2+P-0,6M-PVC-V1-W		0.6 m	
VMC-2+P/Z2-0,6M-PVC-V1-W	●	0.6 m	
VMC-2+P/Z2-0,3M-PVC-V1-W-Y213512 ²⁾	●	0.3 m	
VMC-2+PE		field attachable	

CI models

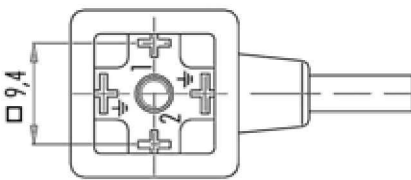
VMCI-2+P-0,3M-PVC-V1-W		0.3 m	 <p>ground bridged</p>
VMCI-2+P/Z2-0,3M-PVC-V1-W	●	0.3 m	
VMCI-2+P-0,6M-PVC-V1-W		0.6 m	
VMCI-2+P/Z2-0,6M-PVC-V1-W	●	0.6 m	
VMCI-2+P/Z2-0,3M-PVC-V1-W-Y ²⁾	●	0.3 m	
VMCI-2+PE		field attachable	

1) with integrated surge protection diode

2) In combination with dual sensors of series F31K

Also available with PUR cable and open ends, other lengths on request

8. Test devices for sensors

With our test devices for sensors you can check the function without an external power supply thanks to the built-in batteries. The test device indicates the switching state of the sensor both visually and acoustically.

In this way, sensors which are hard to see can also be simply and quickly tested. Faults can be localized and the relevant device replaced.

In addition, you have the option of making adjustments to the sensors before the electric installation is complete.

Benefits:

- Simple operation
- Visual and acoustic signaling
- Portable test devices with battery or rechargeable battery operation
- Adjustment of the sensor before the installation is complete
- Detection of wiring faults
- Test function check/battery test
- Includes two 9V block batteries

ST 03



- 2-LED display for the switching state of npn and pnp sensors
- 3 terminals for 0V, 18V, and test output
- Checking DC sensors with 2, 3, and 4-wire technology as well as for sensors with NAMUR interface (not to be used in potentially explosive conditions)
- Maximum load current 100mA
- Includes two 9V block batteries

1-1350



- 5-LED display for the switching states
- 4 terminals for 0V, 18V (pulsed, test output 1 and 2)
- Testing of AC and DC sensors in 2, 3 and 4-wire technology
- Test function check/battery test
- Includes two 9V block batteries

Chemical resistance

The following compilation of various materials provides reference for the use of our sensors and accessories under certain ambient conditions.

Chemical resistance to	V2A	ABS	Epoxy	PBT	PC	POM	PP	PPS	PS	PVC	Brass, nickel-plated
Acetone	+	-	-	+	-	+	+	+	-	-	+
Formic acid	20°C	40%	+	10%	-	-	85%	O	40%	50%	+
Ammonia	+	25%	O	10%	-	+	+	+	+	O	O
Gasoline	+	25%	+	+	O	+	-	+	-	+	+
Benzene	+	-	+	+	-	+	-	+	-	-	+
Brake fluid	-	O	-	-	-	+	+	-	-	-	
Butane	-	+	+	-	+	+	+	+	-	+	+
Butanol	-	-	-	-	-	+	+	-	-	40°C	+
Calcium chloride	-	+	-	10%	+	+	+	+	+	60°C	+
Chlorobenzene	20°C	-	+	-	-	+	-	-	-	-	□
Diesel oil	-	+	+	+	O	+	60°C	+	-	-	□
Acetic acid	20°C	25%	O	+	10%	10%	70%	+	50%	40°C	O
Formaldehyde	+	30%	50%	30%	-	+	40%	37%	40%	+	+
Frigen 113	-	-	-	-	+	-	-	+	-	+	□
Fruit juice	+	-	+	-	+	+	+	-	-	+	+
Glycerin	+	+	+	+	O	+	+	+	+	60°C	+
Heating oil	-	O	+	+	O	+	60°C	+	-	-	+
Hydraulic fluid	-	-	-	-	+	+	60°C	-	-	+	□
Caustic potash	-	50%	O	3%	-	+	50%	-	50%	60°C	□
Potassium chloride	+	-	-	-	+	+	+	-	+	60°C	+
Potassium hydroxide	+	-	-	-	-	-	+	-	-	-	+
Linseed oil	+	+	-	-	+	+	+	-	+	+	+
Methanol	+	-	+	+	-	+	+	+	-	+	+
Methylene chloride	+	-	-	-	-	O	O	+	-	-	-
Lactic acid	20°C	80%	+	-	+	+	+	-	80%	O	-
Mineral oils	+	-	+	+	-	+	+	+	-	+	+
Engine oils	+	+	-	+	-	+	+	+	O	-	□
Sodium carbonate	+	+	-	-	+	+	+	-	+	-	+
Sodium chloride	+	+	-	-	+	+	+	-	+	+	+
Sodium hydroxide	20°C	+	-	-	-	-	+	-	-	-	+
Sodium hydroxide solution	20°C	50%	-	3%	-	+	+	-	50%	+	□
Nitric acid	66%	-	-	-	10%	-	25%	-	10%	+	-
Hydrochloric acid	-	O	-	10%	20%	-	+	-	10%	O	-
Lubricating oil	+	-	+	-	+	O/+	+	-	-	-	□
Carbon disulfide	+	-	-	-	-	+	+	-	-	O	□
Sulfuric acid	-	50%	-	28%	50%	-	80%	50%	50%	70%	-
Seawater (cold)	+	-	+	+	-	+	+	+	-	+	+
Soap suds	+	-	+	-	O	+	+	-	-	+	+
Detergent	+	-	-	-	-	-	+	-	-	-	□
Turpentine oil	+	-	+	-	O	-	+	-	-	+	+
Carbon tetrachloride	+	-	-	-	O	-	-	-	-	O	+
Toluene	+	-	+	+	-	+	-	+	-	-	+
Trichloroethylene	+	-	-	+	-	-	-	O	-	-	+
Water	+	+	68°C	68°C	+	+	+	+	+	60°C	+
Tartaric acid	20°C	+	+	-	+	10%	+	-	+	60°C	+
Xylene	+	-	-	+	-	+	-	+	-	-	□
Zinc sulfate	-	+	-	-	+	-	+	-	-	-	□
Citric acid	20°C	+	+	-	10%	+	+	-	+	-	+

+: resistant / O: conditionally resistant / -: not resistant / □: no data

..°C: to ... °C resistant / ..%: to ...% solution resistant

Date of edition: 2009-09-01

Model Number	Page	Model Number	Page	Model Number	Page
1-1350	69	KFD2-SOT2-Ex2	60	NBN3-F31-Z8-V16-V15	19
14-14361	52	KFD2-SRA-Ex4	60	NBN3-F31-Z8-V16-V16	19
14-14366	52	KFD2-ST2-Ex2	60	NBN3-F31-Z8-V18	19
14-1436X	52	KFD2-VM-Ex1.35	61	NBN40-L2-A2-V1-3G-3D	34
AL2109-P-1820-Ex2/25/49/115	48	KFD2-VM-Ex1.35.L	61	NBN40-L2-E2-V1-3G-3D	34
AVM14	53	KFU8-DWB-1.D	61	NBN40-U1K-E2-3G-3D	34
AVS14	53	KFU8-UFC-Ex1.D	61	NBN40-U1K-N0	33
BT115A	23	KFU8-UFT-Ex2.D	61	NBN40-U1K-N0-V1	33
BT115B	23	KHA6-SH-Ex1	60	NBN40-U4K-N0-V1	33
BT115XA	23	L32/LV32-Ex2/35/47/73C	45	NBN4-V3-E2	12
BT32	16	L32/LV32-Ex2/47/73c	45	NBN4-V3-E2-3G-3D	12
BT32-F25-0	16	L36/LV36-Ex/40b/116	45	NCB1,5-6,5M25-N0	26
BT32XAS	16	M11/MV11-Ex/40b/112	45	NCB1,5-6,5M25-N0-V1	26
BT32XS	16	MBN5-V3-N	40	NCB1,5-8GM25-N0	27
BT33	16	MC60-12GM50-1N	40	NCB1,5-8GM25-N0-V1	27
BT33-F25-0	16	MC60-12GM50-1N-V1	40	NCB10-30GK40-N0	29
BT34	16	MH20-F25-Y43090	16	NCB10-30GM40-N0	29
BT34-F25-2	16	MH5-F25-Y43089	16	NCB10-30GM40-N0-V1	29
BT34-F25-3	16	MH-BT65B	23	NCB10-30GM40-Z0-3G-3D	32
BT34-F25-4	16	MH-F110	37	NCB10-30GM40-Z0-V1-3G-3D	32
BT37	16	MH-F90	37	NCB10-30GM40-Z1-3G-3D	32
BT65A	23	MJ35-F12-1N	40	NCB15-30GM40-N0	29
BT65B	23	MLV11-54-Ex/40b/112	46	NCB15-30GM40-N0-V1	29
BT65XA	23	MLV11-8-500-Ex/40b/112	47	NCB20-L2-N0-V1	33
BT-F110-G	37	NBB10-30GM40-Z0-3G-3D	32	NCB2-12GK35-N0	27
BT-F110-W	37	NBB15-30GM50-E2-3G-3D	32	NCB2-12GM35-N0	27
BT-F130-A	37	NBB15-30GM50-E2-V1-3G-3D	32	NCB2-12GM35-N0-V1	27
BT-F90-G	37	NBB15-U1K-E2-3G-3D	34	NCB2-12GM40-E2-3G-3D	30
BT-F90-W	37	NBB15-U1K-N0	33	NCB2-12GM40-E2-V1-3G-3D	30
C110-2	46	NBB15-U4K-N0-V1	33	NCB2-12GM40-Z0-V1-3G-3D	30
CBN10-F46-N1	39	NBB20-L2-A2-V1-3G-3D	34	NCB2-V3-N0	12
CBN2-F46-N1	39	NBB20-L2-E2-V1-3G-3D	34	NCB2-V3-N0-V5	12
CBN5-F46-N1	39	NBB20-U1K-E2-3G-3D	34	NCB40-FP-A2-P1-3G-3D	34
CCB10-30GM80-N1	39	NBB20-U1K-N0	33	NCB40-FP-N0-P1	33
CCB10-30GM80-N1-V1	39	NBB2-12GM40-Z0-3G-3D	30	NCB40-FP-N0-P1-V1	33
CCN10-F46A-N1	39	NBB2-12GM60-A2-3G-3D	30	NCB4-12GM40-N0	27
CCN5-F46A-N1	39	NBB2-8GM40-E2-V1-3G-3D	30	NCB4-12GM40-N0-V1	27
CJ10-30GK-A2-3D	39	NBB2-V3-E2	12	NCB50-FP-A2-P1-3G-3D	34
CJ10-30GM-A2-3D	39	NBB2-V3-E2-3G-3D	12	NCB50-FP-E2-P1-V1-3G-3D	34
CJ10-30GM-E2-3G-3D	39	NBB2-V3-E2-V5	12	NCB5-18GK40-N0	28
CJ1-12GK-N	39	NBB2-V3-E3-3G-3D	12	NCB5-18GM40-N0	28
CJ15-40-N	39	NBB2-V3-US	12	NCB5-18GM40-N0-V1	28
CJ2-18GK-N	39	NBB3-V3-Z4	12	NCB5-18GM40-Z0-3G-3D	31
CJ40-FP-A2-P1-3D	39	NBB3-V3-Z4-V5	12	NCB5-18GM40-Z0-V1-3G-3D	31
CJ40-FP-N-P1	39	NBB4-12GM50-E2-3G-3D	30	NCB5-18GM70-N0	28
CJ40-FP-N-P4	39	NBB4-12GM50-E2-V1-3G-3D	30	NCB8-18GM40-N0	28
CJ4-12GK-N	39	NBB5-18GM40-Z0-3G-3D	31	NCB8-18GM40-N0-V1	28
CJ6-18GK-N	39	NBB5-18GM60-A2-V1-3G-3D	31	NCN15-30GK40-N0	29
CVM14	53	NBB8-18GM50-E2-3G-3D	31	NCN15-30GM40-N0	29
DM 06-05 NDFEB	40	NBB8-18GM50-E2-V1-3G-3D	31	NCN15-30GM40-N0-V1	29
DM 10-10 NDFEB	40	NBB8-18GM60-A2-V1-3G-3D	31	NCN15-30GM40-Z0-3G-3D	32
DM 20-10 NDFEB	40	NBN30-U1K-E2-3G-3D	34	NCN3-F25F-N4-V1	18
DM 25-32-07	40	NBN30-U1K-N0	33	NCN3-F25-N4-0,14	13
DM 60-31-15	40	NBN30-U4K-N0-V1	33	NCN3-F25-N4-5M	18
DVM14	53	NBN3-F25-E8-0,14	13	NCN3-F25-N4-K	13
FD0-VC-Ex4.FF	62	NBN3-F25-E8-3G-3D-5M	18	NCN3-F25-N4-V1	18
FD0-VC-Ex4.PA	62	NBN3-F25-E8-5M	18	NCN3-F25-SN4-0,14	13
GL121-IR-EX2/32/40a/98a	44	NBN3-F25-E8-K	13	NCN3-F25-SN4-5M	18
GL30-IR-EX2/32/40a/98a	44	NBN3-F25-E8-V1	18	NCN3-F25-SN4-V1	18
GL50-IR-EX2/32/40a/98a	44	NBN3-F25-E8-V1-3G-3D	18	NCN3-F31-B3B-V1	20
GL80-IR-EX2/32/40a/98a	44	NBN3-F25F-E8-V1	18	NCN3-F31-B3B-V1-K	20
H160	46	NBN3-F25F-E8-V1-3G-3D	18	NCN3-F31-B3B-V1-K-3G-3D	20
H50	46	NBN3-F25-Z8-0,14	13	NCN3-F31-B3B-V1-V1	20
H60	46	NBN3-F25-Z8-5M	18	NCN3-F31K-B3B-B31	22
H85-2	46	NBN3-F25-Z8-V1	18	NCN3-F31K-N4	21
K2	16	NBN3-F31-E8-B13-3G-3D	20	NCN3-F31K-N4-K	21
K3	16	NBN3-F31-E8-K	20	NCN3-F31K-N4-K-S	21
K4	16	NBN3-F31-E8-K-K	20	NCN3-F31K-N4-S	21
KCD0-SD-Ex1.1245	61	NBN3-F31-E8-K-K-3G-3D	20	NCN3-F31K-N4-V1-V1	21
KCD2-SR-1.LB	60	NBN3-F31-E8-V1	20	NCN3-F31-N4-K	19
KCD2-SR-2	60	NBN3-F31-E8-V1-3G-3D	20	NCN3-F31-N4-K-K	19
KCD2-SR-Ex1.LB	60	NBN3-F31-E8-V16-V15	20	NCN3-F31-N4-V1	19
KCD2-SR-Ex2	60	NBN3-F31-E8-V18	20	NCN3-F31-N4-V16-K	19
KFA6-DWB-Ex1.D	61	NBN3-F31-E8-V18-3G-3D	20	NCN3-F31-N4-V16-V1	19
KFA6-SOT2-Ex2	60	NBN3-F31K-E8	22	NCN3-F31-N4-V16-V16	19
KFA6-SR2-Ex2.W	60	NBN3-F31K-E8-3G-3D	22	NCN3-F31-N4-V18	19
KFD0-SD2-Ex1.10100	61	NBN3-F31K-E8-K	22	NCN3-F31-N5-V18-V1	19
KFD0-SD2-Ex1.1045	61	NBN3-F31K-E8-K-3G-3D	22	NCN40-L2-N0-V1	33
KFD0-SD2-Ex1.1065	61	NBN3-F31K-E8-V1-V1	22	NCN4-12GK35-N0	27
KFD0-SD2-Ex1.1180	61	NBN3-F31K-Z8	21	NCN4-12GM35-N0	27
KFD0-SD2-Ex2.1045	61	NBN3-F31K-Z8-3G-3D	21	NCN4-12GM35-N0-V1	27
KFD0-SD2-Ex2.1245	61	NBN3-F31K-Z8-B13-3G-3D	21	NCN4-12GM40-E2-3G-3D	30
KFD2-DWB-Ex1.D	61	NBN3-F31K-Z8-K	21	NCN4-12GM40-E2-V1-3G-3D	30
KFD2-SH-Ex1	60	NBN3-F31K-Z8-V1-V1	21	NCN4-12GM40-Z0-3G-3D	30
KFD2-SL2-Ex1	61	NBN3-F31-U8-K	19	NCN4-V3-N0	12
KFD2-SL2-Ex1.B	61	NBN3-F31-U8-V125	19	NCN4-V3-N0-V5	12
KFD2-SL2-Ex1.LK	61	NBN3-F31-U8-V18	19	NCN50-FP-A2-P1-3G-3D	34
KFD2-SL2-Ex2	61	NBN3-F31-Z8-K	19	NCN50-FP-N0-P1	33
KFD2-SL2-Ex2.B	61	NBN3-F31-Z8-K-3G-3D	19	NCN8-18GK40-N0	28
KFD2-SR2-Ex2.W-SM	61	NBN3-F31-Z8-K-K	19	NCN8-18GM40-N0	28
KFD2-SR2-2.W-SM	61	NBN3-F31-Z8-V1	19	NCN8-18GM40-N0-V1	28
KFD2-SOT2-Ex1.N	60	NBN3-F31-Z8-V1-3G-3D	19	NCN8-18GM40-Z0-3G-3D	31

Date of edition: 2009/09/01

Model Number	Page	Model Number	Page	Model Number	Page
NCN8-18GM50-E2-3G-3D	31	PL4-F25-N4-S	14	V1-G-N-10M-PVC	65
NCN8-18GM50-E2-V1-3G-3D	31	PM104-F90-IU-V15	37	V1-G-N-2M-PVC	65
NJ0,8-4-5-N	26	PM1104-F90-IUE8-V15	37	V1-G-N-5M-PVC	65
NJ0,8-5GM-N	27	PMI120-F90-IUE8-V15	37	V1-G-N4-10M-PUR	65
NJ0,8-F-N	33	PMI120-F90-IU-V15	37	V1-G-N4-10M-PVC	65
NJ1,5-18GM-N-D	28	PMI210-F110-IU-V1	37	V1-G-N4-2M-PUR	65
NJ1,5-18GM-N-D-V1	28	PMI360-F110-IU-V1	37	V1-G-N4-2M-PVC	65
NJ1,5-6-5-N	26	PMI360D-F130-IE8-V15	37	V1-G-N4-5M-PUR	65
NJ1,5-8GM-N	27	PMI510-F110-IU-V1	37	V1-G-N4-5M-PVC	65
NJ1,5-8GM-N-V1	27	PMI80-F90-IUE8-V15	37	V1S-G	64
NJ1,5-F-N	33	PMI80-F90-IU-V15	37	V1S-G-2M-PVC	66
NJ10-22-N	26	PMI810-F110-IU-V1	37	V1S-G-N4-0,5M-PVC	66
NJ10-22-N-G	26	PMI960-F110-IU-V1	37	V1S-G-Q2	64
NJ10-30GKK-N	29	PSM58X	53	V1S-W	64
NJ10-30GK-N	29	PSS58X	53	V1S-W-2M-PVC	66
NJ10-30GK-SN	29	PVM14	53	V1S-W-N4-0,5M-PVC	66
NJ10-30GM50-E2-3G-3D	32	PVM58X	53	V1-W	64
NJ10-30GM50-E2-V1-3G-3D	32	PVS14	53	V1-W-10M-PUR	65
NJ10-30GM-N	29	PVS58X	53	V1-W-2M-PUR	65
NJ10-30GM-N-V1	29	RC10-14-N0	35	V1-W-5M-PUR	65
NJ10-F-N	33	RC10-14-N3	35	V1-W-N-10M-PVC	65
NJ15-30GKK-N	29	RC15-14-N0	35	V1-W-N-2M-PVC	65
NJ15-30GK-N	29	RC15-14-N3	35	V1-W-N-5M-PVC	65
NJ15-30GK-N-150	29	RJ15-14-N	35	V1-W-N4-10M-PUR	65
NJ15-30GK-SN	29	RJ15-N	35	V1-W-N4-10M-PVC	65
NJ15-30GM50-E2-3G-3D	32	RJ21-N	35	V1-W-N4-2M-PUR	65
NJ15-30GM50-E2-V1-3G-3D	32	RJ43-N	35	V1-W-N4-2M-PVC	65
NJ15-30GM-N	29	RL32-54-Ex2/47/73c	46	V1-W-N4-5M-PUR	65
NJ15S+U1+N	33	RL32-55-Ex2/47/73c	46	V1-W-N4-5M-PVC	65
NJ20-40-N	29	RL32-8-H-800-Ex2/47/73c	47	VAA-4E2A-G1-ZE/PEXT-S	56
NJ20S+U4+N	33	RL32-8-H-800-RT-Ex2/47/73c	47	VAA-4E2A-G1-ZE/P-S	56
NJ2-11-N	26	RL36-55-Ex/40b/116	46	VAA-4E2A-G5-N/V2-Ex	56
NJ2-11-N-G	26	RL36-8-2000-Ex/40b/116	47	VAN-115/230AC-K17	55
NJ2-11-SN	26	RSI58X-*****1	52	VAN-115/230AC-K24	55
NJ2-11-SN-G	26	RSI58X-*****6	52	VAN-G4-PE-4A	55
NJ2-12GK-N	27	RSI58X-*****X	52	VAN-KE2-2PE	55
NJ2-12GK-SN	27	RVI58X-*****1	52	VAR-KE3-TERM	57
NJ2-12GM-N	27	RVI58X-*****6	52	VAZ-2FK-B3	57
NJ2-12GM-N-V1	27	RVI58X-*****X	52	VAZ-FK-R-BK	57
NJ25-50-N	29	RVI84	52	VAZ-FK-R-YE	57
NJ2-V3-N	12	SC2-N0-GN	25	VAZ-T1-FK-1M-PUR-V1-W	57
NJ2-V3-N-V5	12	SC2-N0-YE	25	VAZ-T1-FK-V1R	57
NJ3-18GK-S1N	28	SC3,5-G-N0	25	VAZ-TERM	57
NJ3-18GK-S1N-130	28	SC3,5-N0-BU	25	VBA-2A-KE2-I/U	56
NJ40-FP-SN-P1	33	SC3,5-N0-GN	25	VBA-2E2A-G12-ZAJ/EA2L	56
NJ4-12GK-N	27	SC3,5-N0-WH	25	VBA-2E-KE2-I/U-V3,0	56
NJ4-12GK-SN	27	SC3,5-N0-YE	25	VBA-4E2A-G1-ZE/PEXT-S	56
NJ4-12GM-N	27	SJ10-N	25	VBA-4E2A-G1-ZE/P-S	56
NJ4-12GM-N-V1	27	SJ15-N	25	VBA-4E4A-CB1-ZE/J/E2J	56
NJ4-30GM-N-200	29	SJ2-S1N	25	VBA-4E4A-G12-ZAJ/EA2L	56
NJ5-11-N	26	SJ2-SN	25	VBA-4E4A-KE-ZE/E2	56
NJ5-11-N-G	26	SJ3,5-S1N	25	VBA-4E-G12-ZAJ	56
NJ5-18GK-N	28	SJ3,5-SN	25	VBA-4E-G4-Pt100	56
NJ5-18GK-N-150	28	SJ30-N	25	VBA-4E-KE-ZE	56
NJ5-18GK-SN	28	SJ5-G-N	25	VBA-LT2-G1	57
NJ5-18GM50-E2-3G-3D	31	SJ5-K-N	25	VBG-DN-K20-D	55
NJ5-18GM50-E2-V1-3G-3D	31	SJ5-N	25	VBG-DN-K20-DMD	55
NJ5-18GM-N	28	SLC14-750/133	48	VBG-PB-K20-D	55
NJ5-18GM-N-V1	28	SLC30-1500/133	48	VBG-PB-K20-DMD	55
NJ5-30GK-S1N	29	SLC90-1800/133	48	VBP-HH1-V3,0-V1	57
NJ6-22-N	26	ST 03	69	VMA-2+P/Z2-0,3M-PVC-V1-W	68
NJ6-22-N-G	26	U-G1FFA	57	VMA-2+P/Z2-0,3M-PVC-V1-W-Y213510	68
NJ6-22-SN	26	V1-4A-E2-10M-PUR	66	VMA-2+P/Z2-0,6M-PVC-V1-W	68
NJ6-22-SN-G	26	V1-4A-E2-5M-PUR	66	VMA-2+P-0,3M-PVC-V1-W	68
NJ6-F-N	33	V15-G-10M-PUR	65	VMA-2+P-0,6M-PVC-V1-W	68
NJ6S1+U1+N1	33	V15-G-2M-PUR	65	VMA-2+PE	68
NJ8-18GK-N	28	V15-G-5M-PUR	65	VMB-2+P/Z2-0,3M-PVC-V1-W	68
NJ8-18GK-N-150	28	V15-W-10M-PUR	65	VMB-2+P/Z2-0,3M-PVC-V1-W-Y213511	68
NJ8-18GK-SN	28	V15-W-2M-PUR	65	VMB-2+P/Z2-0,6M-PVC-V1-W	68
NJ8-18GM-N	28	V15-W-5M-PUR	65	VMB-2+P-0,3M-PVC-V1-W	68
NJ8-18GM-N-V1	28	V15-W-PG9	64	VMB-2+P-0,6M-PVC-V1-W	68
OCS2000-M1K-N2	46	V16-G	64	VMB-2+PE	68
OCT300-M1K-N2	47	V16-G-N4-10M-PVC	65	VMBI-2+P/Z2-0,3M-PVC-V1-W	68
OFR-100/100	46	V16-G-N4-15M-PVC	65	VMBI-2+P/Z2-0,3M-PVC-V1-W-Y	68
PL1-F25-B3B-K	14	V16-G-N4-20M-PVC	65	VMBI-2+P/Z2-0,6M-PVC-V1-W	68
PL1-F25-B3B-S	14	V16-G-N4-5M-PVC	65	VMBI-2+P-0,3M-PVC-V1-W	68
PL1-F25-E8-K	14	V16S-G	64	VMBI-2+P-0,6M-PVC-V1-W	68
PL1-F25-E8-S	14	V16-W	64	VMBI-2+PE	68
PL2-F25-E8-K	14	V16-W-N4-10M-PVC	65	VMC-2+P/Z2-0,3M-PVC-V1-W	68
PL2-F25-E8-S	14	V16-W-N4-15M-PVC	65	VMC-2+P/Z2-0,3M-PVC-V1-W-Y213512	68
PL2-F25-N4-K	14	V16-W-N4-20M-PVC	65	VMC-2+P/Z2-0,6M-PVC-V1-W	68
PL2-F25-N4-S	14	V16-W-N4-5M-PVC	65	VMC-2+P-0,3M-PVC-V1-W	68
PL2-F25-N5-K	15	V1-8A-E2-10M-PUR	66	VMC-2+P-0,6M-PVC-V1-W	68
PL2-F25-N5-S	15	V1-8A-E2-5M-PUR	66	VMC-2+PE	68
PL2-F25-SN4-K	14	V18-G	64	VMCI-2+P/Z2-0,3M-PVC-V1-W	68
PL3-F25-N4-K	14	V18-W	64	VMCI-2+P/Z2-0,3M-PVC-V1-W-Y	68
PL3-F25-N4-S	14	V1-Clip	64	VMCI-2+P/Z2-0,6M-PVC-V1-W	68
PL3-F25-N5-K	15	V1-G	64	VMCI-2+P-0,3M-PVC-V1-W	68
PL3-F25-N5-S	15	V1-G-10M-PUR	65	VMCI-2+P-0,6M-PVC-V1-W	68
PL3-F25-SN4-K	14	V1-G-2M-PUR	65	VMCI-2+PE	68
PL4-F25-N4-K	14	V1-G-5M-PUR	65	VR10	46

Date of edition: 2009/09/01

FACTORY AUTOMATION – SENSING YOUR NEEDS



Pepperl+Fuchs sets the standard in quality and innovative technology for the world of automation. Our expertise, dedication, and heritage of innovation have driven us to develop the largest and most versatile line of industrial sensor technologies and interface components in the world. With our global presence, reliable service, and flexible production facilities, Pepperl+Fuchs delivers complete solutions for your automation requirements – wherever you need us.

Contact

Pepperl+Fuchs GmbH
Lilienthalstraße 200
68307 Mannheim · Germany
Tel. +49 621 776-4411 · Fax +49 621 776-27-4411
E-mail: fa-info@pepperl-fuchs.com

Worldwide Headquarters

Pepperl+Fuchs GmbH · Mannheim · Germany
E-mail: fa-info@pepperl-fuchs.com

USA Headquarters

Pepperl+Fuchs Inc. · Twinsburg · USA
E-mail: fa-info@us.pepperl-fuchs.com

Asia Pacific Headquarters

Pepperl+Fuchs Pte Ltd · Singapore
Company Registration No. 199003130E
E-mail: fa-info@sg.pepperl-fuchs.com

www.pepperl-fuchs.com

 **PEPPERL+FUCHS**
SENSING YOUR NEEDS