

ARUSH SWITCHGEARS

1801, 2nd Floor Bhagirath Palace, Delhi
9312211087/9811514724
enquiry@arushswitchgears.com
www.arushswitchgears.com

Numerous Brands
One Supplier

ARUSH



At *Arush Switchgears*, it is our always our constant endeavour to help our esteemed customers get the best on most competitive market prices.

Our strong alliance with the broad-list of brands helps us to always offer an extensive range of items, new product introductions from latest technologies as soon as they are available in the market. There are new products that are introduced on regular basis, from over a ocean of brands.

We'd really appreciate if you can share your product requirements for following brands & categories to get the best quotes from us.

Our Range

Automation & Control Gears	Lighting
Batteries	Pneumatics
Cables & Wires	Power Supplies
Connectors	Relays
Displays & Optoelectronics	ESD Control & Clean Room
Electricals	Sockets & Circuit Breakers
Enclosure & Storage	Switches
Fuses	Test & Measurement
HVAC, Fan & Thermal Management	Tools

Our Top Brands



Introduction			General index	
Absolute Encoders	General description		Singleturn and multiturn absolute encoders	2
			PARALLEL interface	4
			SSI interface	6
			ICO interface (incremental)	8
			PROFIBUS interface	10
Singleturn Absolute Encoders	PARALLEL	size 40	EA40 A - B	13
	PARALLEL	size 50	EA50 A	15
	PARALLEL SSI ICO	size 58 63 90 115	EA58 B - C EA63 A - D - E - G EA90 A EA115 A	17
Multiturn Absolute Encoders	PARALLEL SSI	size 58 63 90 115	EAM58 B - C EAM63 A - D - E - F - G EAM90 A EAM115 A	23
	PROFIBUS	size 58 63 90 115	EAM58 B - C EAM63 A - D - E - F - G EAM90 A EAM115 A	31
Absolute Special Encoders	Singleturn absolute encoder for turret tool change		EA40 T - U	37
	Flameproof singleturn absolute encoder		EAX80 A - D	39
	Accessories		Joints	41
			Connectors	42
			Output configurations	43
			Use precaution	45





SINGLETURN AND MULTITURN ABSOLUTE ENCODERS GENERAL DESCRIPTION

Operating principle

The working principle of an absolute encoder and of an incremental encoder is very similar in fact a rotating disc, with transparent and opaque windows, interrupts a light beam acquired by the photo receivers; those transform the luminous impulses into electric impulses that are processed and transmitted by the output electronics.

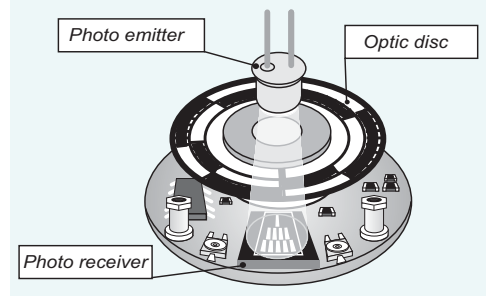

Absolute code

The absolute encoder presents important operating differences from the incremental one: in the incremental encoders the position is determined by the number of impulses from the zero index, in the absolute encoders the position is determined by the read of the output code, which is only for each position inside the turn; consequently the absolute encoders do not lose the real position when the power supply is turned off (even if shifted). To a following power up (thanks to the direct coding on the disc) the position is up to date and available and it is not necessary, as for the incremental encoders, to seek the zero index. The output code is used to define the absolute position. The most obvious choice is the binary code which can be easily manipulated from the external control device for the reading of the position and it is not necessary to have any particular conversion operations. As the code is extracted directly from the disc (which is in rotation) the synchronization and acquisition of the position at the moment of the variation between one code and another becomes very difficult. If we take, for example two consecutive binary codes as 7 (0111) and 8 (1000) we can note that all the bits of the code change their state; a reading made at the moment of the transition could result completely wrong as it is impossible that the variations are instantaneous and contemporary. Due to this problem is used a binary code variant, the Gray code, which has the particularity that in the passage between the two consecutive codes (even from the last to the first code) only one bit changes its state.

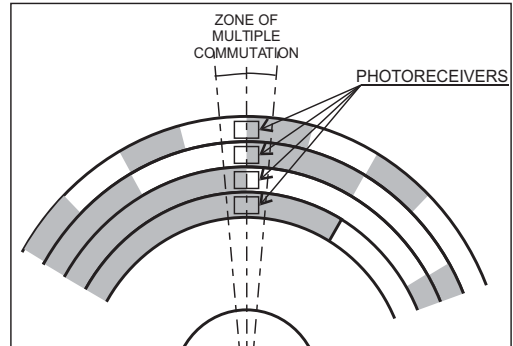

The Gray code can easily be converted with a simple combinatory circuit, in binary code:

DECIMAL	BINARY	GRAY
0	0000	0000
1	0001	0001
2	0010	0011
3	0011	0010
4	0100	0110
5	0101	0111
6	0110	0101
7	0111	0100
8	1000	1100
9	1001	1101
10	1010	1111
11	1011	1110
12	1100	1010
13	1101	1011
14	1110	1001
15	1111	1000

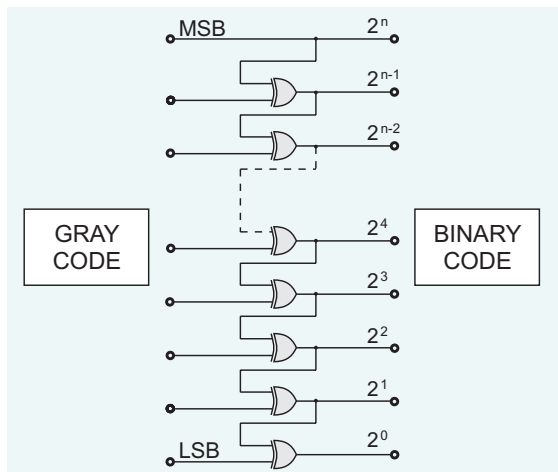

2 bit optic disc with Binary code

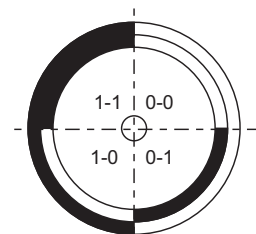

2 bit optic disc with Gray code

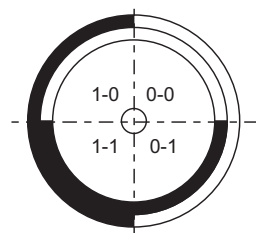

' Gray - excess - code '

POSITION	GRAY
0	0000
1	0001
2	0011
3	0010
4	0110
5	0111
6	0101
7	0100
8	1100
9	1101
10	1111
11	1110
0	0000

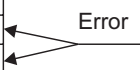

POSITION	GRAY
0	0011
1	0010
2	0110
3	0111
4	0101
5	0100
6	1100
7	1101
8	1111
9	1110
10	1010
11	1011

When the number of positions is not a power of 2 the property to change only one bits is lost in the passage from the last value to the first and vice versa. For example if we want to bring about an absolute encoder with 12 positions/turn, the code should be like the one shown in the table on the side:

one notes that at the passage between the positions 11 and 0 the contemporary state change of 3 bit can involve reading errors and this is, as previously seen, not acceptable.

The Gray - excess - code is used not to loose the characteristics of the commutation of only one bit, making correspond the 0 position to the Gray code relative to the value N, where N is the number that, subtracted from the Gray code converted into binary code, supplies the exact position value.

The calculation of N number is:

$$N = \frac{2^n - IMP}{2}$$

Where: *IMP* is the number of impulses/turn (only even impulses)

2^n the number of impulses multiple powers of 2, immediately superior to *IMP*

In our case the codification will be:

$$N = \frac{2^4 - 12}{2} = \frac{16 - 12}{2} = 2$$

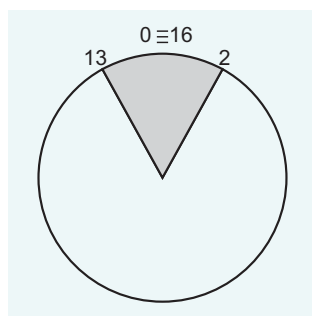

Example : conversion of position 5

The Gray code of the position 5 is 0100 which converted into binary is 0111 (7 in decimal). Subtracting from 7 the *N* value we will obtain the value of the real position that is 7-2 = 5

Singleturn absolute encoders

A singleturn absolute encoder permits the acquisition of a precise code concerning the angular position of the shaft it is coupled to, even in the event of power failure. Therefore, each single degree position is converted into an accuracy code proportional to the number of bits, in the grey or binary format.

For Eltra singleturn encoders, the current maximum resolution attainable is 8192 pos/turn (13 bits).

Multiturn absolute encoders

The range of multiturn absolute encoders is identified by the initials EAM. The multiturn encoder is an advanced instrument that permits the application field for encoders to be extended significantly. In fact, while maintaining high resolution on a single turn (up to 8182 Pos/turn), it permits an extended turn count (4096 turns). This leads to an extremely important linear development; at the same time it maintains flexibility for single customer specifications and extends the number of turns. The system used in this range uses a main shaft to which one or more mechanical reducers are associated in cascade form. This permits the reading of an extremely precise code, even after physical movements of the mechanical device without a power supply. At the moment, we have been able to reach a code position of 25 bits, equal to 33.554.432 Pos/turn. The safety and performance characteristics typical of ELTRA encoders obviously remain, with the added possibility of supplying the device in the most widely ranging interface combinations, both electronic and mechanical.



SV001GB0803A



Eltra

Via Monticello di Fara, 32 bis - Sarego (VI) - ITALY - Tel.+39 0444 436489 R.A. - Fax +39 0444 835335

<http://www.eltra.it> E-mail: eltra@eltra.it

ELTRA reserves the right to make any modifications without any prior notice



PARALLEL INTERFACE GENERAL DESCRIPTION

Parallel Interface

Singleturn and multiturn absolute encoders with a parallel output are the tradition form of encoders. These in fact supply the entire position data at the output, bit by bit, relative to the resolution adopted by the device. Whilst this form of transmission is the standard for singleturn encoders, it is more burdensome for multiturn encoders where the number of bits per turn, and on the turns, becomes high; singleturn encoders can arrive at 13 data bits, whilst multiturn ones reach 25 bits and beyond. This is without counting the normal command signals that go from count inversion to data blocking the data on the outputs (LATCH), etc. This is why data transmission methods, serially (SSI) or through field buses (PROFIBUS, CANBUS, etc.) have been introduced.

Output data in grey format:

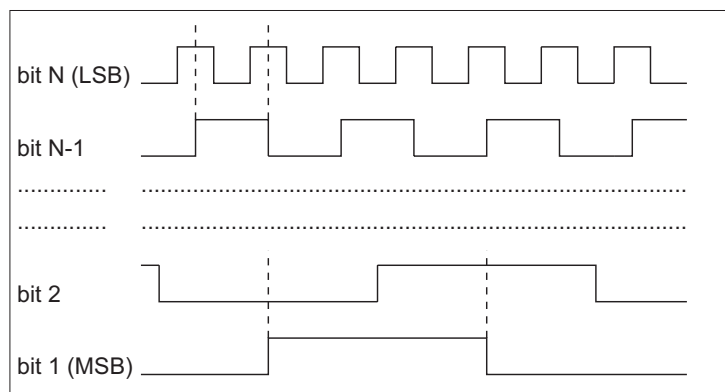

Apart from the grey format output, the data is also available in binary form. In the latest generation of encoders, the binary code is obtained by ASIC devices processing the signals in grey code supplied by the photo-receiver circuit. The problem of discriminating the status of the binary code remains however, given that unlike the grey code, binary has multiple bit switching between the various phases.

In the past, to avoid this problem and therefore to supply an output code free from errors, we used an output synchronism signal (STROBE), whilst with the adoption of programmable logics this limitation has been overcome. Output data in binary format:

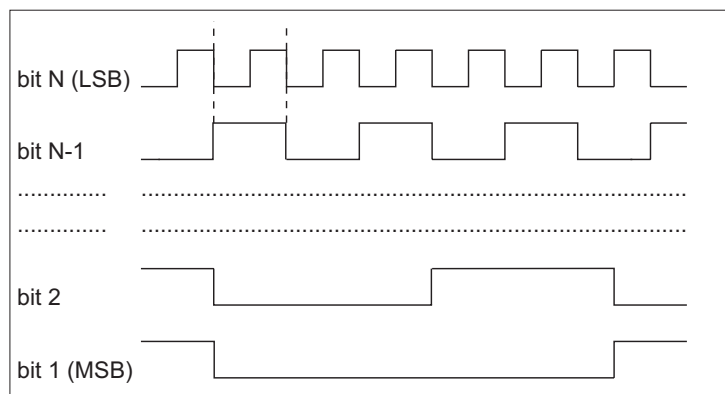

There are various output stages and these cover all the electrical-electronic requirements demanded by the most widely ranging controllers. Usually, the conformations made available are: NPN, NPN OPEN-COLLECTOR, PNP OPEN COLLECTOR, PUSH-PULL.

Command inputs and optional outputs

As mentioned earlier, external commands exist for processing and handling encoder data, even before it leaves the same; among these we shall look at a few really indispensable ones.

STANDARD SIGNALS PRESENT ON ALL THE ENCODERS:

-U/D: this permits inversion of the absolute code; it is equivalent to making the encoder shaft rotate in the opposite direction.

OPTIONAL SIGNALS (contact ELTRA for availability):

-LATCH: this command permits the data to be frozen. In this way, whilst the encoder shaft continues to turn, the output data of the same remains the same.

-TRISTATE: this permits the outputs to be placed in an isolation condition, or better, it puts them in a high impedance status, similar to an open circuit and this for example permits several encoders to be placed in parallel and the activation of just one at a time (only with electronic Push-Pull).

-G/B: this permits the automatic passage of the code from the grey format to the binary one and vice versa.

-STROBE: this is an output present only with the binary code and permits the acquisition of the binary code in a stable condition.

INPUT	STATE HIGH	STATE LOW
U/D	Inverts the code	Does not invert the code
LATCH	Blocks the code	Does not block the code
TRISTATE	Isolates the outputs	Does not isolate the output
G/B	Gray code	Binary code



Introduction

Continual evolution in the automation field has led to a continuous and growing requirement for precision in measurement devices and therefore also in absolute encoder. To satisfy these demands, absolute encoders have been created with high resolution. These however have the problem of needing a number of wires that grows with the number of bits and with the accuracy. To try to reduce installation costs and to simplify the wiring, the SSI interface was created. This performs the measurement data transmission in serial mode, usually using only two signals (CLOCK and DATA), independently of encoder accuracy.

Description

The SSI interface permits the transfer of the absolute encoder position information through a serial line, synchronised with a clock. The following figure shows the block diagram of an encoder with an SSI interface:

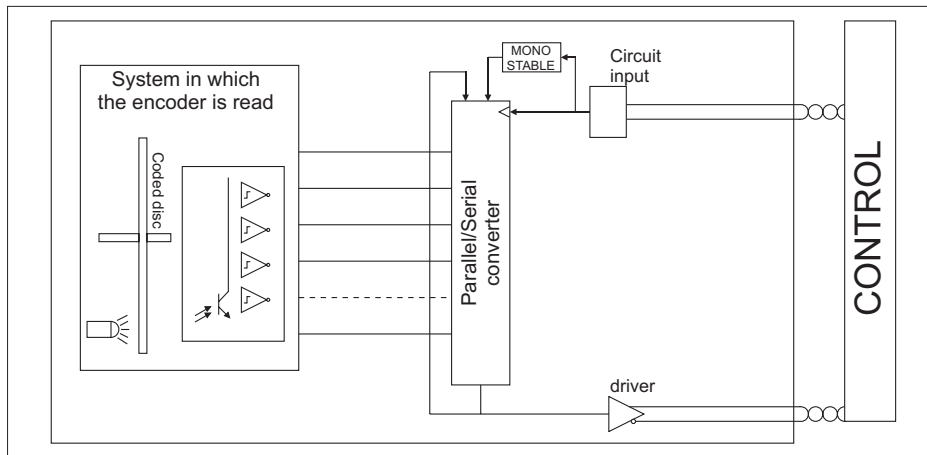

The encoder with an SSI interface is constituted by the classic absolute encoder position measurement system including: a light source, a disc with transparent and opaque zones, photo-electric receivers, comparison/trigger circuits, a parallel/serial converter, a mono-stable circuit, an input circuit for the clock signal and by an output driver for the data signal.

The value of the position is taken by the encoder reading system and continually sent to a parallel/serial converter (constituted essentially of a "shift register" with parallel loading). When the mono-stable circuit is activated by a clock signal transition, the data is memorised and sent to the output, scheduled according to the clock's own signal. The CLOCK and DATA signals are transmitted differentially (RS422) to increase immunity from interference and to be able to support long transmission distances.

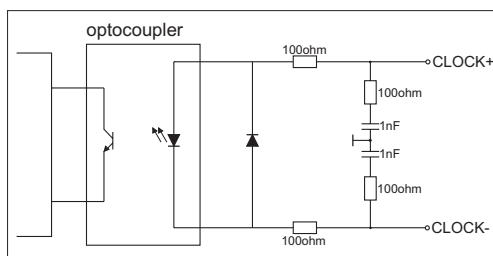

CLOCK signal circuit input

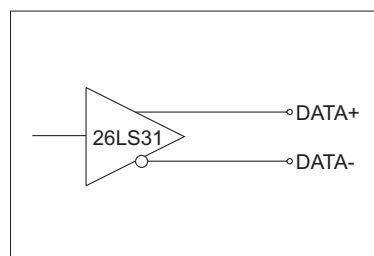

DATA signal circuit output

Operating principle

In rest conditions, the CLOCK and DATA lines are at a high logical level and the mono-stable circuit is disabled (high level).

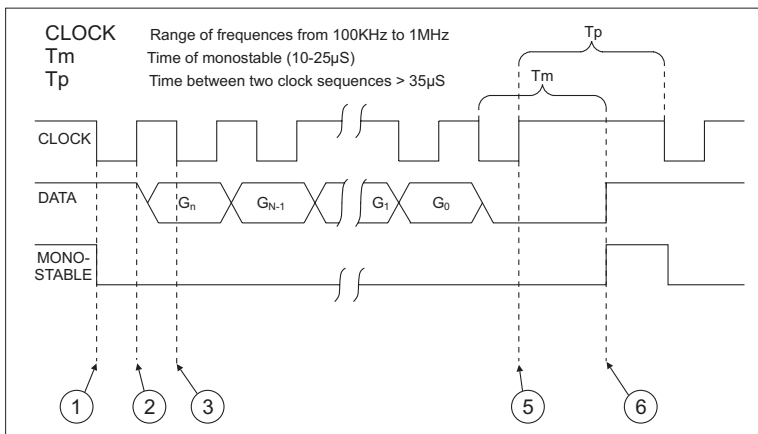

1. On the first CLOCK signal descent front, the mono-stable is activated and the parallel value present at the input to the P/S converter is memorised in the shift register.
2. On the CLOCK signal ascent front, the most significant bit (MSB) is placed in the output on the DATA line.
3. On the CLOCK descent front when the signal is stable the controller acquires the level from the DATA line, which is the value of the most significant bit, the mono-stable is re-activated.
4. On each further ascent front of the CLOCK impulse sequence, the successive bits up to the least significant one are placed in the output on the DATA line and acquired by the control on the descent front.
5. At the end of the CLOCK impulse sequence when the external control has also acquired the value of the least significant (LSB) the CLOCK impulse sequence is interrupted and therefore the mono-stable is no longer re-activated.
6. Once the mono-stable time (Tm) has elapsed, the DATA line returns to a high logical level and the mono-stable disables itself.

Transmission protocol

The frame length of the transmitted data depends only on the type of encoder (single turn or multi-turn) and not on the total number of encoder bits. In fact, the standard frame length for a single turn encoder monogiro is 13 bits, whilst for a multi-turn one it is 25 bits. The alignment of the significant data inside the frame is at the centre, as shown by the table below:

T	2 ⁿ																								Ta	2 ⁿ	n					
12	4096	1	1	G _{n+11}	G _{n+10}	G _{n+9}	G _{n+8}	G _{n+7}	G _{n+6}	G _{n+5}	G _{n+4}	G _{n+3}	G _{n+2}	G _{n+1}	G _n	G _{n-1}	G _{n-2}	G _{n-3}	G _{n-4}	G _{n-5}	G _{n-6}	G _{n-7}	G _{n-8}	G _{n-9}	G _{n-10}	G _{n-11}	G _{n-12}	G _{n-13}	0	1	8192	13
11	2048	1	1	0	G _{n+10}	G _{n+9}	G _{n+8}	G _{n+7}	G _{n+6}	G _{n+5}	G _{n+4}	G _{n+3}	G _{n+2}	G _{n+1}	G _n	G _{n-1}	G _{n-2}	G _{n-3}	G _{n-4}	G _{n-5}	G _{n-6}	G _{n-7}	G _{n-8}	G _{n-9}	G _{n-10}	G _{n-11}	G _{n-12}	0	0	1	4096	12
10	1024	1	1	0	0	G _{n+9}	G _{n+8}	G _{n+7}	G _{n+6}	G _{n+5}	G _{n+4}	G _{n+3}	G _{n+2}	G _{n+1}	G _n	G _{n-1}	G _{n-2}	G _{n-3}	G _{n-4}	G _{n-5}	G _{n-6}	G _{n-7}	G _{n-8}	G _{n-9}	G _{n-10}	G _{n-11}	0	0	0	1	2048	11
9	512	1	1	0	0	0	G _{n+8}	G _{n+7}	G _{n+6}	G _{n+5}	G _{n+4}	G _{n+3}	G _{n+2}	G _{n+1}	G _n	G _{n-1}	G _{n-2}	G _{n-3}	G _{n-4}	G _{n-5}	G _{n-6}	G _{n-7}	G _{n-8}	G _{n-9}	G _{n-10}	0	0	0	0	1	1024	10
8	256	1	1	0	0	0	0	G _{n+7}	G _{n+6}	G _{n+5}	G _{n+4}	G _{n+3}	G _{n+2}	G _{n+1}	G _n	G _{n-1}	G _{n-2}	G _{n-3}	G _{n-4}	G _{n-5}	G _{n-6}	G _{n-7}	G _{n-8}	G _{n-9}	0	0	0	0	0	1	512	9
7	128	1	1	0	0	0	0	0	G _{n+6}	G _{n+5}	G _{n+4}	G _{n+3}	G _{n+2}	G _{n+1}	G _n	G _{n-1}	G _{n-2}	G _{n-3}	G _{n-4}	G _{n-5}	G _{n-6}	G _{n-7}	G _{n-8}	0	0	0	0	0	0	1	256	8
6	64	1	1	0	0	0	0	0	0	G _{n+5}	G _{n+4}	G _{n+3}	G _{n+2}	G _{n+1}	G _n	G _{n-1}	G _{n-2}	G _{n-3}	G _{n-4}	G _{n-5}	G _{n-6}	G _{n-7}	0	0	0	0	0	0	0	1	128	7
5	32	1	1	0	0	0	0	0	0	0	G _{n+4}	G _{n+3}	G _{n+2}	G _{n+1}	G _n	G _{n-1}	G _{n-2}	G _{n-3}	G _{n-4}	G _{n-5}	G _{n-6}	0	0	0	0	0	0	0	0	1	64	6
4	16	1	1	0	0	0	0	0	0	0	0	G _{n+3}	G _{n+2}	G _{n+1}	G _n	G _{n-1}	G _{n-2}	G _{n-3}	G _{n-4}	G _{n-5}	0	0	0	0	0	0	0	0	0	1	32	5
3	8	1	1	0	0	0	0	0	0	0	0	0	G _{n+2}	G _{n+1}	G _n	G _{n-1}	G _{n-2}	G _{n-3}	G _{n-4}	0	0	0	0	0	0	0	0	0	0	1	16	4
2	4	1	1	0	0	0	0	0	0	0	0	0	0	G _{n+1}	G _n	G _{n-1}	G _{n-2}	G _{n-3}	0	0	0	0	0	0	0	0	0	0	0	1	8	3
1	2	1	1	0	0	0	0	0	0	0	0	0	0	0	G _n	G _{n-1}	G _{n-2}	0	0	0	0	0	0	0	0	0	0	0	0	1	4	2

The format of the frame transmitted depends on the configuration of the encoder concerning the number of bits per turn and the number of bits for the turns.

n = number of bits on the turn
T = number of bits for the turns

$$T_a = \frac{T_m - T_c}{2}$$

Tc = clock period
 Tm = monoflop time

SV003GB0803A



Eltra

Via Monticello di Fara, 32 bis - Sarego (VI) - ITALY - Tel. +39 0444 436489 R.A. - Fax +39 0444 835335
<http://www.eltra.it> E-mail: eltra@eltra.it

ELTRA reserves the right to make any modifications without any prior notice



ICO INTERFACE GENERAL DESCRIPTION

Introduction

Absolute encoders with an incremental output code combine the advantages of absolute encoders with those of incremental ones, in a single product. These are to all effects, absolute encoders because they measure the absolute position inside the turn and not the incremental position with respect to the zero notch, however, the output signals are those of incremental encoders. The advantages are considerable because compared to classic absolute encoders, the number of wires for the wiring is considerably reduced (above all when the bits start to be numerous). Also, for position reading, a simple counter is sufficient for the incremental encoder, instead of boards or multi I/O instruments.

Description

Concerning the reading system, an absolute encoder with an incremental output is exactly the same as for a standard absolute encoder, in other words, a beam of light, captured by photo-receivers and interrupted by a rotating disc with transparent and opaque zones. The disc however, is special in that apart from having the tracks for the absolute code bits, it also has electrical tracks of the incremental type, staggered at 90° and in phase with the absolute code. The following figure shows the encoder block diagram:

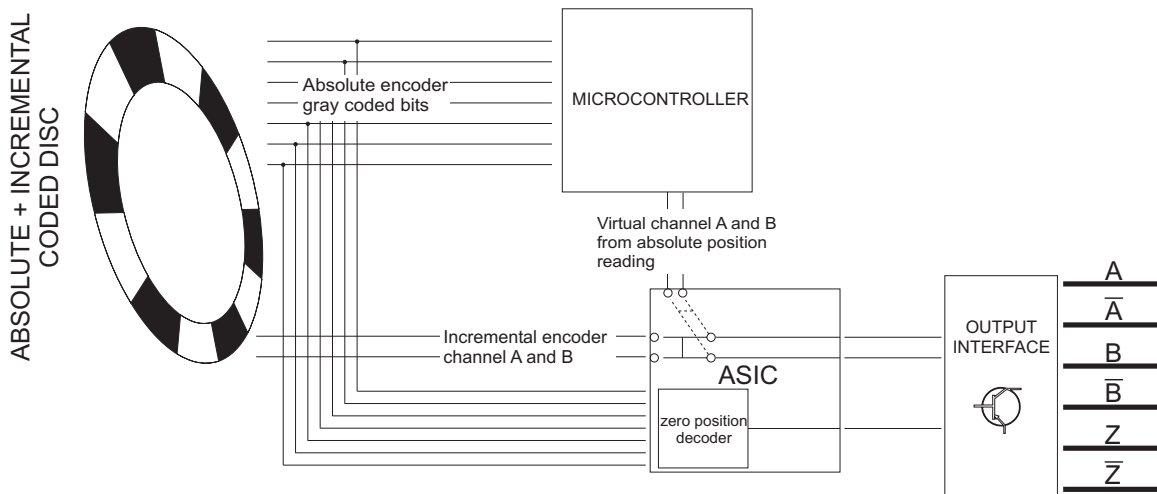

A micro-controller is distinguished that manages the encoder operation and the initialisation sequences; it reads the absolute position and controls the ASIC device. This latter implements a switch for channels A and B and a position decoder for generating the Z channel. Finally, the output interface converts the signals from the ASIC into the electronic output levels.

Operating principle

When the encoder is powered up, it goes into a stand-by state, in which the A, B and Z channels are at a low logical level and the READ output is disabled: in this state, the encoder does not work and any shaft rotation does not produce effects on the output channel status.

To make the encoder operate, it is necessary to activate the RESTART input for at least 50 ms.. In this way, the micro-controller managing the encoder reads the absolute position and send a number of impulses equal to the absolute position detected, in output to channels A and B. The impulse "train" in question is preceded by an impulse on channel Z, permitting the possible zeroing of the counter.

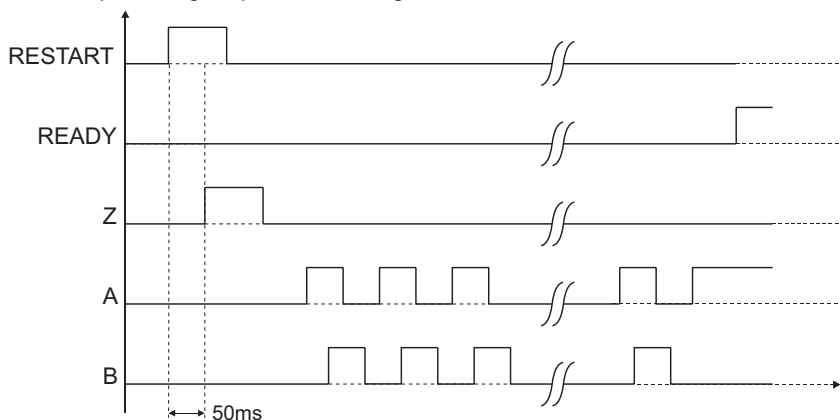

After this impulse train has been sent, the READY output assumes the high logical level and the counter count will be equal to the position of the absolute encoder. At this point, the micro-controller releases control of output channels A, B, and Z and the part that manages the incremental encoder starts to function.

This series of operations is defined as the "START-UP" sequence, at the end of which, the encoder becomes effectively operational.

U/D

The U/D (Up-Down) input, permits inversion of the rotation direction permitting the encoder count to increased/decreased. In particular, by connecting this input to the power supply positive, we increase the count with the clockwise rotation of the shaft (seen from the front), vice versa, by connecting to the negative, (or by leaving it disconnected), we obtain an increase with ant-clockwise shaft rotation.

Restart

When the RESTART input is activated for at least 50 ms., this permits the encoder to execute the START-UP sequence. This sequence can be automatically executed at the moment the power supply is switched on, by permanently connecting the RESTART input to the power supply positive.

Ready

The READY output indicates the encoder operational status. When found at a low logical state, this means that the encoder is not functioning and that it is necessary to activate the RESTART input. At the end of the "START-UP" procedure, it goes to a high logical level, indicating that the encoder is ready to operate. The READY output also indicates any encoder malfunctioning due for example, to power supply voltage interruptions or to internal faults to the extent that if continuously monitored, it can be used as an authentic alarm.

Pursuit

If the encoder is moving due to a drive offset or vibrations during the "START-UP" procedure, the position read at the start of the procedure itself, may not be the same as the one read at the end causing an error between the real position and the one effectively sent in the form of incremental impulses. The encoder check this by reading the absolute position value also after sending the incremental impulse sequence; if there are any differences, it continues to send impulses until the absolute position read is the same as the one sent in the form of incremental impulses. Only at this moment is the "START-UP" procedure terminated and the READY output is activated. If the rotation speed is faster than that at which the encoder performs acquisition and the sending of the absolute position, the READY output remains disabled.

Resolution levels

Absolute encoders with incremental output code are available with various levels of resolution, up to a maximum of 1024 imp/turn. The number of impulses specified, refers to the incremental ones; in this way, a 1000 imp/turn encoder has a resolution level equal to a 4000 pos./turn absolute encoder. This resolution is obtained by setting a x 4 multiplication factor in the encoder reading device.

Output electronics

The output electronics available are Push-Pull and Line Driver; the READY output is the push-pull type.



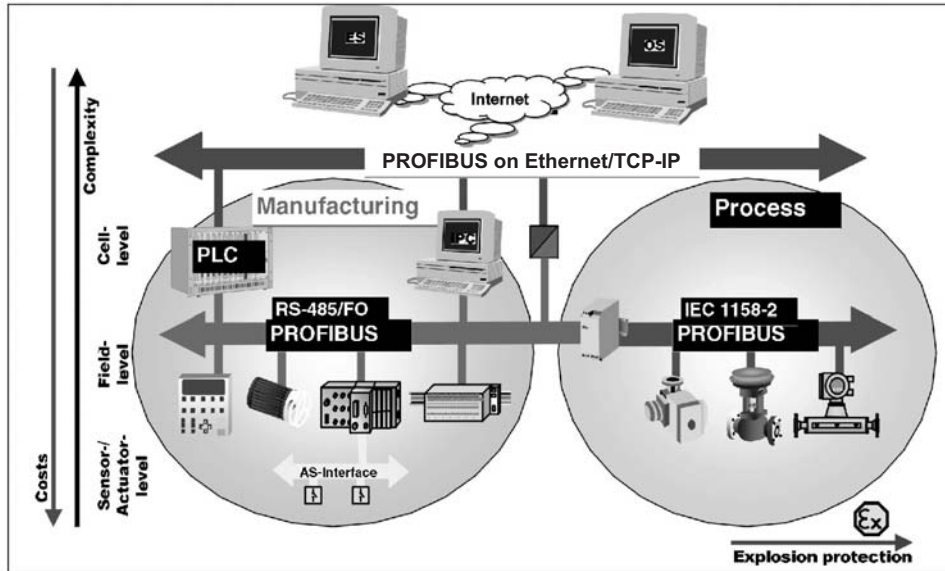

INDUSTRIAL PROFIBUS NETWORK

General information about Profibus

PROFIBUS (Process Field Bus) is a serial communications standard for devices inserted in automation networks (Field Bus); it is an open protocol defined by DIN 19246 that became European Standard EN 50170 volume 2. Profibus is promoted by Siemens and is highly diffused throughout Europe: thanks to the definition of three distinct communication profiles DP, FMS and PA this field bus is suitable for most requirements arising in automation systems. Starting with applications requiring the high speed cyclical exchange of a reduced number of bits (Profibus DP), on to the management of relatively complex communications between "intelligent" devices (Profibus FMS) or tasks strictly concerning process automation (Profibus PA).

Hereinafter attention will be especially focussed on the DP variation (Decentralized Periphery), the standard solution for managing devices via the bus, that in most cases are I/O modules, sensors/transducers or actuators on a low level in automation systems.

PROFIBUS DP characteristics

-NETWORK TOPOLOGY : the structure is a typical bus structure (terminated at the physical ends) in which up to 126 devices can be connected at the same time. If the physical support is an RS485 interface, up to 32 nodes can be inserted without the need to use signal repeaters/re-generators.

-PHYSICAL LEVEL : apart from the RS485 differential transmission serial technology, fibre optic connection can be used. It should be noted that in any case, DP and FMS devices can co-exist in the same network, given that they use the same physical communication interface (in reality, they are the same levels 1 and 2 of the ISO/OSI stack. The standard establishes extremely precise communication BaudRates ranging from a minimum of 9.6 kBaud up to a maximum of 12 Mbaud.

-DEVICES PRESENT IN THE NETWORK : a distinction is made between three possible classes of devices: class 1 Master DP (DPM1), class 2 Master DP (DPM2) and Slave. The first class includes all the devices that can cyclically exchange information with the distributed peripheral; in other words ones that can directly manage the network I/O data with the other nodes, mainly slaves. Class 2 masters on the other hand are foreseen for configuring and monitoring functions of network status and the devices connected to it. The slaves have the task of directly exchanging information with the external world, both in and out. Typical examples of slaves are digital I/O, encoders, drives, valves, various transducers, etc.

-BUS ACCESS METHODS : being a bus with mono-master or multi-master operating possibilities, two cases must be distinguished: the Token Passing method for exchanging information about network management between the possible masters present and classic polling interrogation for master-slave communication.

-MAIN FUNCTIONS : as follows, we briefly list the fundamental peculiarities of the Profibus DP with reference to the main functions implemented in the protocol:

Cyclical data exchange: each master is configured so that after the initial phases concerning slave management, (parameterization and configuration) it can exchange a maximum of 244 input bytes and 244 output bytes with each slave. The rate at which this data exchange takes place at, depends on the communication BaudRate, the nodes present in the network and on the specific bus settings. Given the possibility of arriving at up to 12Mbaud, the Profibus DP is one of the fastest field buses.

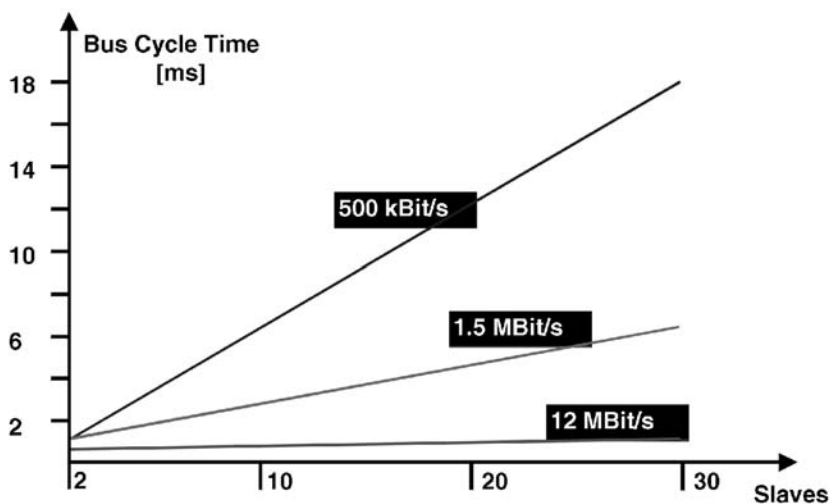

CYCLE TIMES WITH A DP MONO-MASTER NETWORK

Synchronisation : control commands are available (sent by the master in multicast) so as to render the acquisitions synchronous, by a slave, a group, or all the slaves (Freeze Mode) and the same for the output data sent to the slaves (Sync Mode).

Parameterization and configuration security: every slave added to the network must be congruent with what the master managing it expects to be present. In other words, cyclical exchange cannot take place between the master and slave if there is discordance of this type occurs.

Protection mechanisms : a mechanism is present by which both in the master/s and the slave/s, the system overall, goes into a security status if communication between the master and slave is not repeated after a certain period of time that can be set beforehand. Apart from this, in multi-master networks, every master in the network can read all the slaves, whilst they can only write on those that have been parameterized and configured.

Diagnostic functions: each slave can ask the master that parameterized it for a reading of its own diagnostic. In this way, any problems possibly present in the slave can be rapidly localised. Also in this case, the diagnostic can contain up to 244 bytes of information, the first 6 of which are obligatory for each DP slave.

Dynamic slave management: the slaves present in the network can be activated or deactivated. It is also possible to change the addresses of the slaves that make this function possible, via the bus.

Easy network configuration : the main characteristics of each device present in the network are listed in the form of a GSD file, according to a precise syntax present in the Profibus specifications. This makes parameterizing and configuring the device easy through graphic tools suitable for the purpose, such as the Siemens COM PROFIBUS Software.

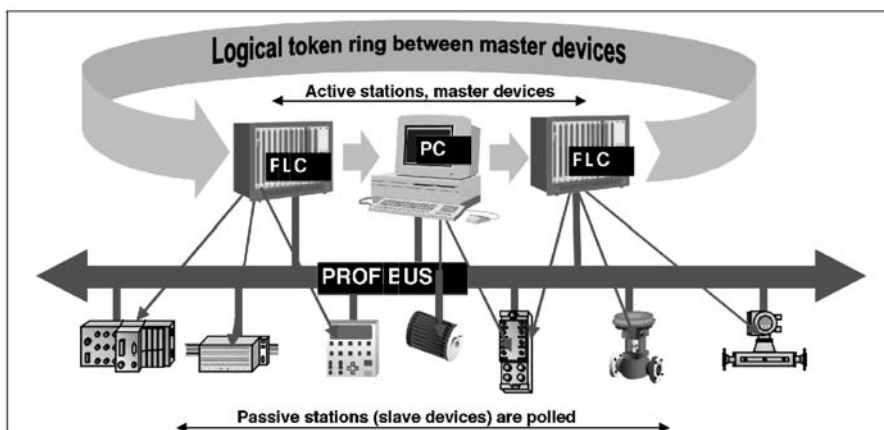

A SINGLE NETWORK CONFIGURATIONS

Master - Slave communications

As already mentioned, the master-slave data exchange takes place cyclically at well defined times, that essentially depend on the topology of the network and the number of nodes present. Before exchange can take place however, it is necessary for the slave parameter setting and configuration phases to have been successful. We now supply some further information about this.

Parameter setting: thanks to this phase, the master sends the slave a series of operating parameters necessary to specify its operation; the standard imposes the sending of 7 obligatory bytes containing the information indispensable for the slave and if there is more data this will be introduced starting from the eighth byte in the DU field (Data Unit, see the Profibus DP specifications for more information) of the communication frame up to a maximum possible 224 bytes.

Configuration: this phase can only take place once the master has successfully set the slave's parameters. Here, the master specifies the number and type of data, or better, how many bytes to exchange with the slave both incoming and outgoing. This data is also present in the DU field of the communication frame; if the slave accepts the configuration, it can go on to exchange cyclically with the master.

Cyclical exchange: the master inserts the data it intends to send to a particular slave in the DU field of the frame and receives from the same the input data from the peripheral again in the DU field of the reply frame. During this phase, the slave can advise the master that it has the new diagnostic ready and therefore asks if the master is going to read this information and not the input data from the peripheral in the next polling.

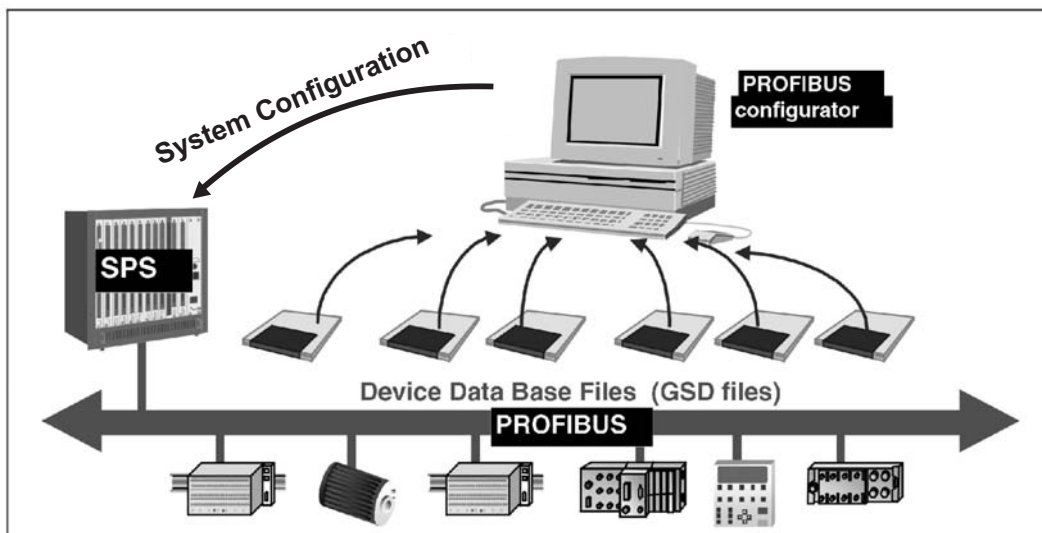

NETWORK CONFIGURATIONS BETWEEN THE GDS FILES





EA40A / B SINGLETURN ABSOLUTE ENCODER

Absolute Encoders

Absolute encoder with reduced dimensions has the following characteristics:

- Resolutions up to 256 imp/turn (8 bit).
- Different electronic configurations with power supply up to 28 Vdc.
- Output cable.
- Speed rotation up to 6000 rpm.
- Protection IP66.



Ordering codes

In case of particular Customer variant separate by a full stop

EA 40 A 256 G 8/28 R P 6 X 6 P R . XXX

EA = singleturn absolute encoder

40 = body dimension

A = mod.EA40A
B = mod.EA40B
Type of flanges

2 / 4 / 8 / 16 / 32 / 64 / 128 / 256
90 / 180
Resolutions
N.B.: For impulse availability contact our offices

G = Gray
Code

5
8 ÷ 28
Encoder power supply (Vdc)

N = NPN (Standard negative logic)
C = NPN OPEN COLLECTOR (Standard negative logic)
R = PNP (Standard positive logic)
U = PNP OPEN COLLECTOR (Standard positive logic)
Electronics output configuration
N.B.: For the optionals on the output configurations contact our offices

XXX = Particular Customer variants indicated by a progressive number from 001 to 999

R = radial
A = axial

P = output cable (standard length 0.5 m)

3 = 3000 with IP66
6 = 6000 max
R.P.M.

X = standard IP54
S = optional IP66
Protection

6 = ø6 mm
Shaft diameter

N = Negative
P = Positive
Logics

EA40A

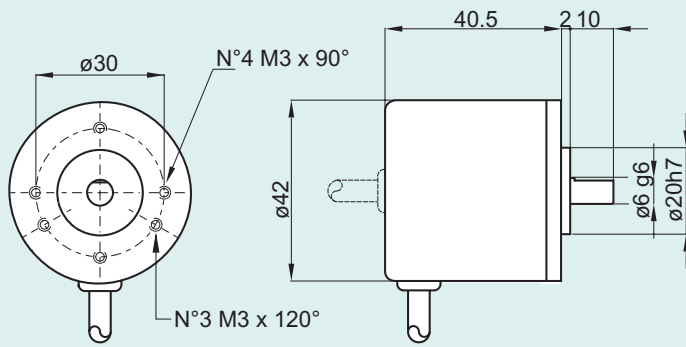

EA40B

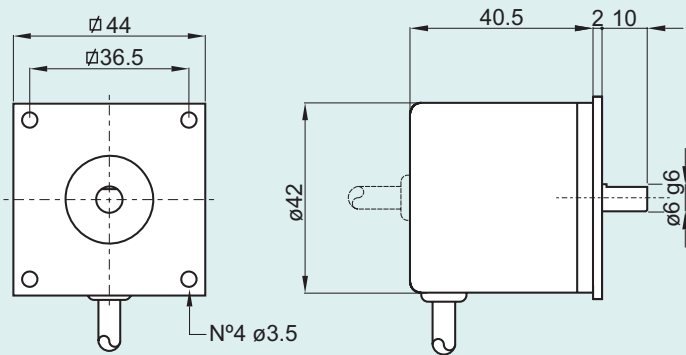

Electronic Characteristics

Resolution	2 / 4 / 8 / 16 / 32 / 64 / 128 / 256 90 / 180
Power supply	5 Vdc / 8 + 28 Vdc
Current consumption without load	150 mA
Max commutable current	40 mA per channel
Electronic output configuration	NPN / NPN OPEN COLLECTOR / PNP / PNP OPEN COLLECTOR
Max output frequency	100 KHz output code
Code	GRAY

Caratteristiche Meccaniche

Shaft diameter (mm)	ø6 g6
Protection	IP54 Standard IP66 Optional
R.P.M. Max	3000 with IP66 6000
Max shaft load	5N (0.5 Kp) axial 5N (0.5 Kp) radial
Shock	50 G per 11 msec
Vibrations	10G 10 + 2000 Hz
Bearings life	10 ⁹ revolutions
Bearings	n°2 ball bearings
Shaft material	Stainless steel AISI303
Body material	Aluminium D11S - UNI 9002/5
Cover material	Special plastic reinforced with glass fibre
Operating Temperature	0° + +60°C
Storage Temperature	-15° + +70°C
Weight	100 g

Connections and standard colours

CABLE COLOURS	FUNCTION	G
green	bit 1 (LSB)	G ⁰
yellow	bit 2	G ¹
blue	bit 3	G ²
brown	bit 4	G ³
pink	bit 5	G ⁴
white	bit 6	G ⁵
gray	bit 7	G ⁶
violet	bit 8	G ⁷
	/	/
	/	/
	/	/
red-blue	U / D	/
black	0 Volt	/
red	+ Vdc	/





EA50A SINGLETURN ABSOLUTE ENCODER

Absolute Encoders

- Absolute encoder size 50 with the following characteristics:
- Resolutions up to 1024 imp/turn (10 bit)
 - Different electronic configuration available with power supply up to 28 Vdc.
 - Output cable and connector.
 - Speed rotation up to 6000 rpm.
 - Protection IP66.



Ordering codes

EA 50 A 360 G 5 N N 6 X 6 P R . XXX

In case of a particular Customer variant separate by a full stop

EA = singleturn absolute encoder

50 = body dimension

A = mod.EA50A Type of flanges

2 / 4 / 8 / 16 / 32 / 64 / 128 / 256 / 512 / 90 / 180 / 360 / 250 / 500 Resolutions

N.B.: For impulse availability contact our offices

G = GRAY Code

5
8 ÷ 28 Encoder power supply (Vdc)

N = NPN (Standard negative logic)
C = NPN OPEN COLLECTOR (Standard negative logic)
R = PNP (Standard positive logic)
U = PNP OPEN COLLECTOR (Standard positive logic)
Electronic output configuration

N.B.: For the options on the output configurations contact our offices

XXX = Particular Customer variants indicated by a un numero progressivo da 001 a 999

R = radial

P = fairled
standard lenght 0.5 m
VB = Connector type 15 pin

3 = 3000 with IP66 R.P.M
6 = 6000

X = IP54
S = optional IP66 (only with fairled) Protection

6 = ø6g6 mm Shaft diameter

N = Negative
P = Positive Logic

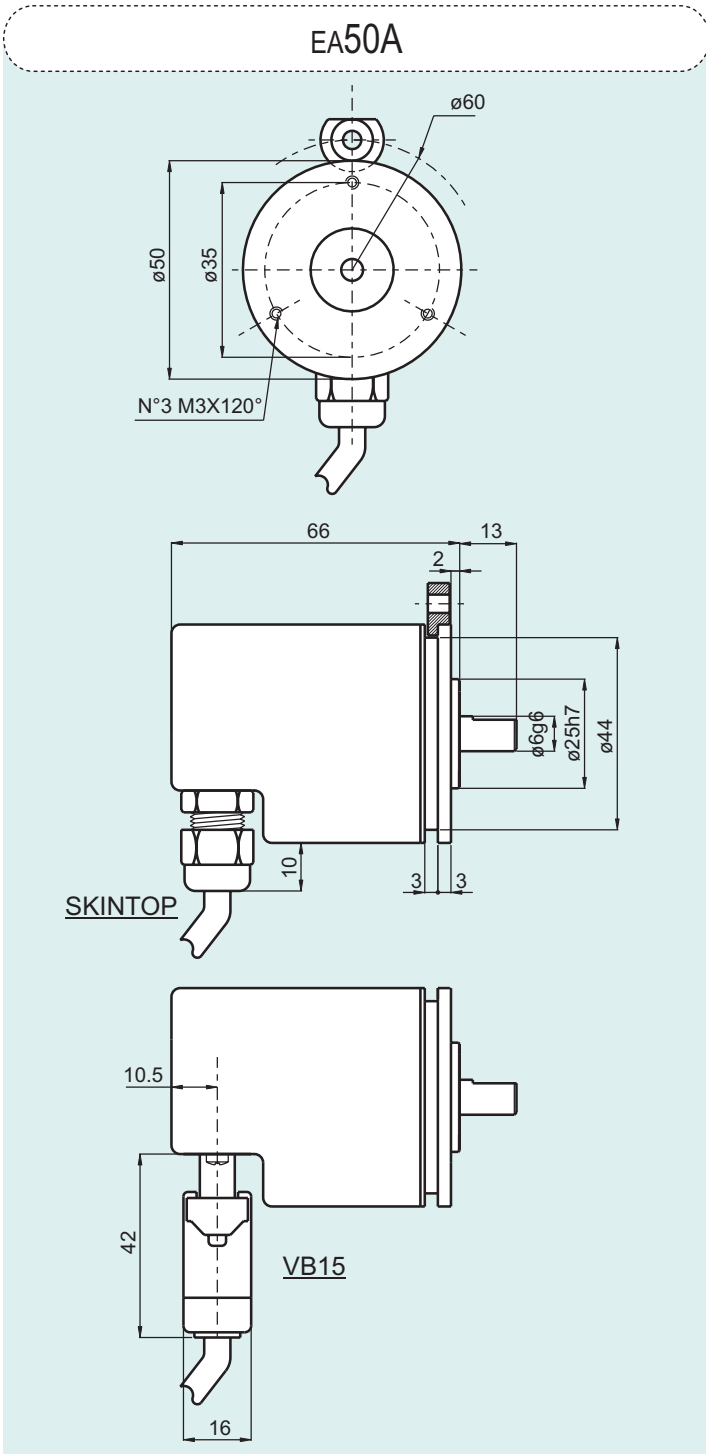

Electronic Characteristics	
Resolution	2 / 4 / 8 / 16 / 32 / 64 / 128 / 256 / 512 90 / 180 / 360 250 / 500
Power supply	5 Vdc / 8 + 28 Vdc
Current consumption without load	150 mA
Max commutable current	40 mA per channel
Electronic output configuration	NPN (negative logic) NPN Open Collector (negative logic) PNP (positive logic) PNP Open Collector (positive logic)
Max output frequency	100 KHz output code
Code	GRAY

Mechanical Characteristics	
Shaft diameter (mm)	ø6 g6
Protection	IP54 - Standard IP66 - Optional (only Skintop)
R.P.M. Max	3000 with IP66 6000 with IP54
Max shaft load	5N (0.5 Kp) axial 5N (0.5 Kp) radial
Shock	50 G per 11 msec
Vibrations	10G 10 + 2000 Hz
Bearings life	10 ⁹ revolutions
Bearings	n°2 ball bearings
Shaft material	Stainless steel AISI303
Body material	Aluminium D11S - UNI 9002/5
Cover material	Special plastic reinforced with glass fibre
Operating Temperature	0° + +60°C
Storage Temperature	-15° + +70°C
Weight	250 g

Connections and standard colours

CABLE COLOURS	FUNCTION	G	PIN "V15MP"
green	bit 1 (LSB)	G ⁰	1
yellow	bit 2	G ¹	2
blue	bit 3	G ²	3
brown	bit 4	G ³	4
pink	bit 5	G ⁴	5
white	bit 6	G ⁵	6
gray	bit 7	G ⁶	7
violet	bit 8	G ⁷	8
gray-pink	bit 9	G ⁸	9
white-green	bit 10	G ⁹	10
	/	/	11
	/	/	12
red-blue	U / D	/	13
black	0 Volt	/	14
red	+ Vdc	/	15





SINGLETURN ABSOLUTE ENCODER EA PARALLEL - SSI - ICO



Description of the PARALLEL singleturn absolute encoder

The series of parallel single turn absolute encoders was created for adaptation to any kind of application. It is available with resolution levels up to 13 bits and therefore of 8192 Positions/Turn. The various models and the different types of flanging mean that it can be used in a vast range of applications, guaranteeing correct operation, even in the most difficult conditions. This series of encoders is available with a cable or connector output and can reach a protection level of up to IP66 depending on the model. The output configurations are both grey code and binary and the output electronics cover all application fields by being available in the NPN, NPN OPEN COLLECTOR, PNP and PUSH PULL formats.

Description of the SSI singleturn absolute encoder

The range of single turn absolute encoders with SSI format output was designed to satisfy the new philosophy of the serial transmission of the data supplied by the encoder.

For this range in fact, the data in the output is formed by a 13 bit word, just like standard, in which the useful bytes are numerically proportional to the resolution chosen for the encoder.

This type of transmission considerably reduces the wiring problem while maintaining the performance of the device the same. In this range of encoders, the data connections are reduced to just four wires; one pair for the position code and one for the clock signal, both in differential logic. The mechanical components available are most diverse and capable of satisfying all dimensional requirements.

Description of the ICO singleturn absolute encoder

The range of single turn absolute encoders with incremental output is the only encoder available on the market that adds the wiring simplicity and data exploitation typical of incremental encoders to the accuracy of absolute encoders. In fact, thanks to the introduction of a micro-controller into this encoder family, it supplies all the advantages of an absolute encoder, while offering an initial position code in incremental format (channels A and B) and a transmission frequency that can be set from 0 to 10 KHz.

As for the Parallel and SSI ranges, the availability of a very broad selection of mechanical configurations is such as to guarantee device interfacing with the customer's most widely varying requirements.

Ordering codes for singleturn absolute encoder

PARALLEL

In case of a particular Customer variant separate by a full stop

EA 63 A 512 G 8/28 N N L 10 X 6 MA R . XXX

EA = singleturn absolute encoder

58 = body dimension
63 = body dimension
90 = body dimension
115 = body dimension

A = mod.EA63 / 90 / 115
B = mod.EA58
C = mod.EA58
D = mod.EA63
E = mod.EA63
G = mod.EA63

Type of flanges

2 / 4 / 8 / 16 / 32 / 64 / 128 / 256 / 512 / 1024 / 2048 / 4096 / 8192
Resolutions
90 / 180 / 360 / 720 / 1440 / 2880
225 / 450 / 900 / 1800 / 3600
250 / 500 / 1000 / 2000 / 4000
 N.B.: For impulse availability contact our offices

B = Binary
G = Gray (standard)

Code

N.B.: For the compensated code of binary encoder (0-XXX) contact the Technical office

5
8 ÷ 28

Encoder power supply (Vdc)

N = NPN (Standard negative logic)
C = NPN OPEN COLLECTOR (Standard negative logic)
R = PNP (Standard positive logic)
U = PNP OPEN COLLECTOR (Standard positive logic)
P = PUSH PULL with short circuit protection (Standard positive logic)

Electronics output configuration

N.B.: For the optionals on the output configurations contact our offices

XXX = Special Customer variants indicated by a progressive number from 001 to 999

R = radial
A = axial

PD = 16 poles cable
 standard output cable 1.5 m
PE = 32 poles cable
 standard output cable 1.5m
MA = Connector "MS" type 19 poles

3 = 3000 with IP66
6 = 6000

R.P.M.

X = IP54
S = optional IP66 excluding EA63G / EA115

Protection

6 = ø 6g6 mm -- 58B
8 = ø 8g6 mm -- 58B -- 63A / D / E -- 90A
9 = ø 9.52g6 mm -- 63 A / D / E -- 90A
10 = ø 10g6 mm -- 58B / C -- 63A / D / E -- 90A -- 115A
11 = ø 11g6 mm -- 115A

Shaft diameter

8 = ø 8H7 mm
9 = ø 9.52H7 mm
10 = ø 10H7 mm
12 = ø 12H7 mm
14 = ø 14H7 mm
15 = ø 15H7 mm

Hole diameter only for mod.63G

L = Latch
S = Strobe to indicate only with binary code
X = to indicate if not use

Options

N = Negative
P = Positive

Logics

Output connections for singleturn absolute PARALLEL encoder

FUNCTION	B / G	16 WAY CABLE COLOUR	32 WAY CABLE COLOUR	PIN M19MP
bit 1 (LSB)	B ⁰ / G ⁰	green	green	A
bit 2	B ¹ / G ¹	yellow	yellow	B
bit 3	B ² / G ²	blue	blue	C
bit 4	B ³ / G ³	brown	brown	D
bit 5	B ⁴ / G ⁴	pink	pink	E
bit 6	B ⁵ / G ⁵	white	white	F
bit 7	B ⁶ / G ⁶	gray	gray	G
bit 8	B ⁷ / G ⁷	violet	violet	H
bit 9	B ⁸ / G ⁸	gray/pink	gray/pink	J
bit 10	B ⁹ / G ⁹	white/green	white/green	K
bit 11	B ¹⁰ / G ¹⁰	brown/green	brown/green	L
bit 12	B ¹¹ / G ¹¹	white/yellow	white/yellow	M
bit 13	B ¹² / G ¹²	yellow/brown	yellow/brown	N
/	/	/	/	P
LATCH	/	/	yellow/gray	R
/	/	/	/	S
0 Volt	/	black	black	T
U / D	/	red/blue	red/blue	U
+ Vdc	/	red	red	V

Ordering codes for singleturn absolute encoder

SSI

In case of a particular Customer variant separate by a full stop

EA 63 A 512 G 8/28 S X X 10 X 6 MC R . XXX

EA = singleturn absolute encoder

58 = body dimension
63 = body dimension
90 = body dimension
115 = body dimension

A = mod.EA63 / 90 / 115
B = mod.EA58
C = mod.EA58
D = mod.EA63
E = mod.EA63
G = mod.EA63

Type of flanges

2 / 4 / 8 / 16 / 32 / 64 / 128 / 256 / 512 / 1024 / 2048 / 4096 / 8192
Resolutions
90 / 180 / 360 / 720 / 1440 / 2880
225 / 450 / 900 / 1800 / 3600
250 / 500 / 1000 / 2000 / 4000
 N.B.: For impulse availability contact our offices

B = Binary
G = Gray (standard)
 N.B.: For the compensated code of binary encoder (0-XXX) contact the Technical office

Code

5
8 ÷ 28
Encoder power supply (Vdc)

S = SSI (Serial Synchronous Interface)
Electronics output configuration
 N.B.: For the optionals on the output configurations contact our offices

XXX = Particular Customer variants indicated by a progressive number from 001 to 999

R = radial
A = axial

PC = 12 poles cable
 standard output cable 1.5 m
MC = Connector "MS" type 7 poles
HA = Connector "H" type 12 poles

3 = 3000 with IP66
6 = 6000

R.P.M.

X = IP54
S = optional IP66 excluding EA63G / EA115

Protection

6 = ø 6g6 mm -- 58B
8 = ø 8g6 mm -- 58B -- 63A / D / E -- 90A
9 = ø 9.52g6 mm -- 63 A / D / E -- 90A
10 = ø 10g6 mm -- 58B / C -- 63A / D / E -- 90A -- 115A
11 = ø 11g6 mm -- 115A

Shaft diameter

8 = ø 8H7 mm
9 = ø 9.52H7 mm
10 = ø 10H7 mm
12 = ø 12H7 mm
14 = ø 14H7 mm
15 = ø 15H7 mm

Hole diameter only for mod.63G

X = not to utilize

Options

X = not to utilize

Logics

Output connections for singleturn absolute SSI encoder

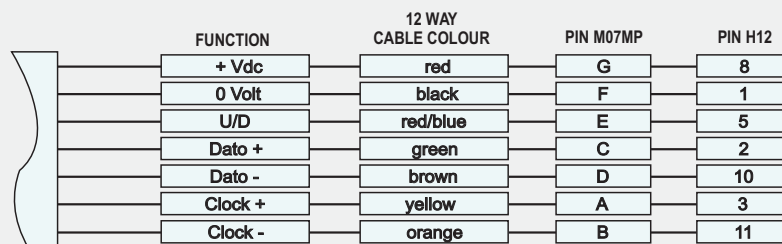

Ordering codes for singleturn absolute encoder

ICO

In case of a particular Customer variant separate by a full stop

EA 63 A 512 I 8/28 L X A 10 X 6 MC R . XXX

EA = singleturn absolute encoder

58 = body dimension
63 = body dimension
90 = body dimension
115 = body dimension

A = mod.EA63 / 90 / 115
B = mod.EA58
C = mod.EA58
D = mod.EA63
E = mod.EA63
G = mod.EA63

Type of flanges

360 / 500 / 512 / 720 / 1000 / 1024

Resolutions

N.B.: For impulse availability contact our offices

I = incremental output code

Code

5
8 ÷ 28

Encoder power supply (Vdc)

L = LINE DRIVER
P = PUSH PULL with short circuit protection

Electronics output configuration

N.B.: For the optionals on the output configurations contact our offices

XXX = Particular Customer variants indicated by a progressive number from 001 to 999

R = radial
A = axial

PC = 12 poles cable
 standard output cable 1.5 m
MA = Connector "MS" type 19 poles

3 = 3000 with IP66
6 = 6000

R.P.M.

X = IP54

S = optional IP66 excluding EA63G / Ea115

Protection

6 = ø 6g6 mm -- 58B
8 = ø 8g6 mm -- 58B -- 63A / D / E
9 = ø 9.52g6 mm -- 63 A / D / E -- 90A
10 = ø 10g6 mm -- 58B / C -- 63A / D / E -- 90A -- 115A
11 = ø 11g6 mm -- 115A

Shaft diameter

8 = ø 8H7 mm
9 = ø 9.52H7 mm
10 = ø 10H7 mm
12 = ø 12H7 mm
14 = ø 14H7 mm
15 = ø 15H7 mm

Hole diameter only for mod.63G

A = 10 KHz (standard)
B = 1 KHz

Options

X = not to utilize

Logics

Output connections for singleturn absolute ICO encoder

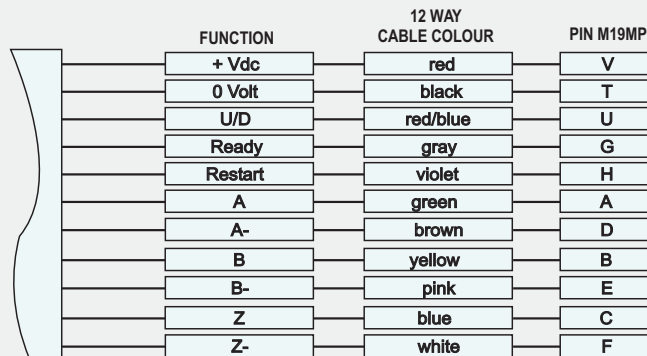

EA63A

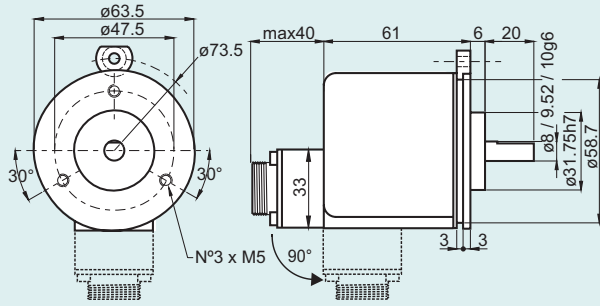

EA58B

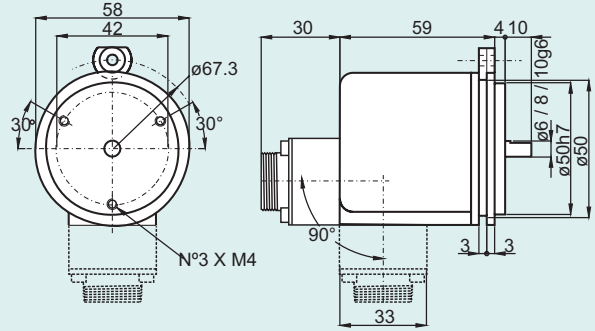

EA58C

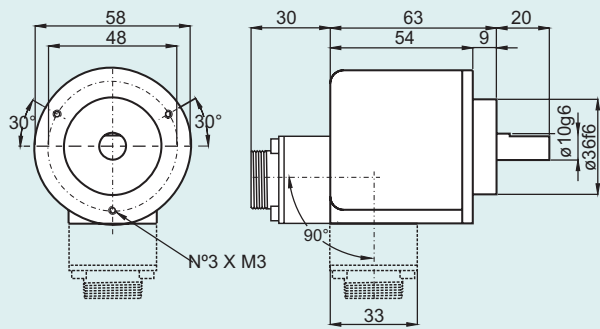

EA63D

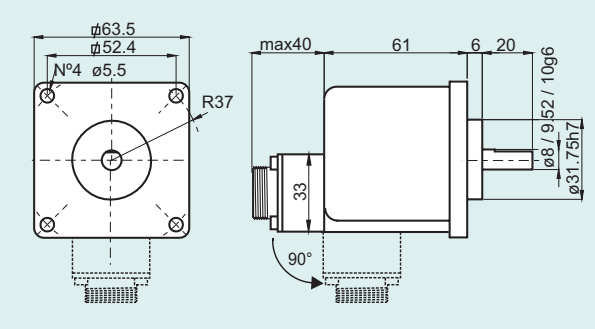

EA63E

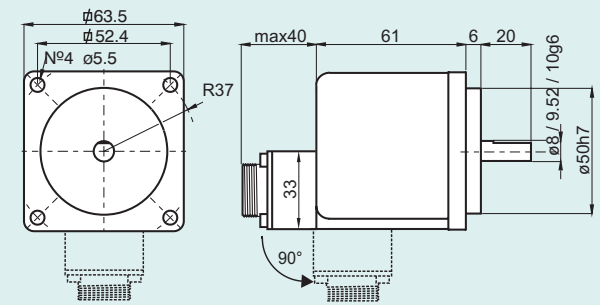

EA63G

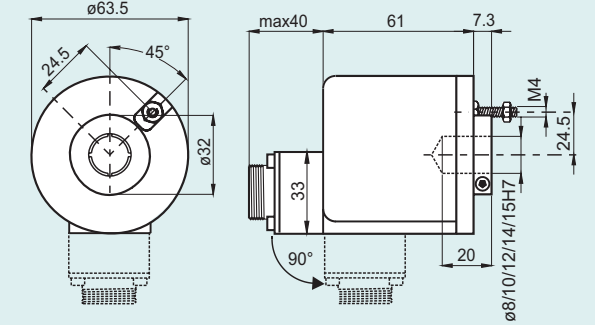

EA90A

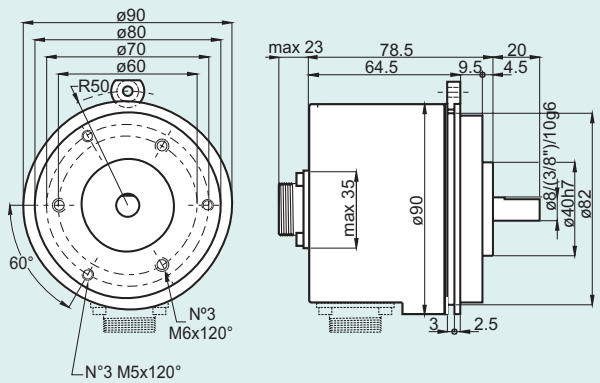

EA115A

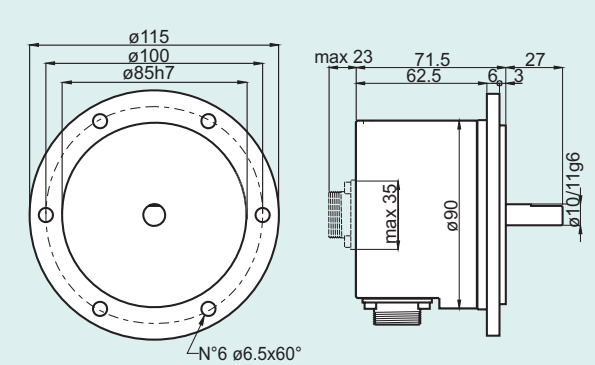

Electronic Characteristics PARALLEL

Resolution	2 / 4 / 8 / 16 / 32 / 64 / 128 / 256 / 512 / 1024 / 2048 / 4096 / 8192 90 / 180 / 360 / 720 / 1440 / 2880 225 / 450 / 900 / 1800 / 3600 250 / 500 / 1000 / 2000 / 4000
Power supply	5 Vdc / 8 + 28 Vdc
Current consumption without load	200 mA
Max commutable current	40 mA per channel
Electronic output configuration	NPN (negative logic) NPN Open Collector (negative logic) PNP (positive logic) PNP Open Collector (positive logic) PUSH PULL (positive logic)
Max output frequency	100 KHz output code $F = \frac{\text{RPM} \times \text{Resolution}}{60}$

Electronic Characteristics SSI

Resolution	2 / 4 / 8 / 16 / 32 / 64 / 128 / 256 / 512 / 1024 / 2048 / 4096 / 8192 90 / 180 / 360 / 720 / 1440 / 2880 225 / 450 / 900 / 1800 / 3600 250 / 500 / 1000 / 2000 / 4000
Power supply	5 Vdc / 8 + 28 Vdc
Current consumption without load	200 mA
Electronic output configuration	SSI (Serial Synchronous Interface)
Monostable time	10 - 25 μ s
Time between two clock sequences	> 35 μ s
Frequency range	100 KHz - 1 MHz

Electronics Characteristics ICO

Resolution	360 / 500 / 512 / 720 / 1000 / 1024
Power supply	5 Vdc / 8 + 28 Vdc
Current consumption without load	200 mA
Max commutable current	40 mA per channel with PUSH PULL 20 mA per channel with LINE DRIVER
Electronic output configuration	LINE DRIVER PUSH PULL
Max output frequency	100 KHz output code $F = \frac{\text{RPM} \times \text{Resolution}}{60}$
Transmission frequency	1 KHz - 10 KHz

Mechanical Characteristics

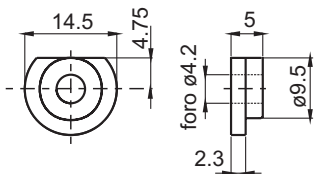
Shaft diameters (mm)	$\phi 6$ g6 -- 58B $\phi 8$ g6 -- 58B -- 63A/D/E -- 90A $\phi 9.52(3/8)$ g6 -- 63A/D/E -- 90A $\phi 10$ g6 -- 58B/C -- 63A/D/E -- 90A -- 115A $\phi 11$ g6 -- 115A
Hole diameters (mm)	$\phi 8$ H7 --63G $\phi 9$ H7 --63G $\phi 10$ H7 --63G $\phi 12$ H7 --63G $\phi 14$ H7 --63G $\phi 15$ H7 --63G
R.P.M. Max	6000 continuous 3000 continuous for --63G 3000 with Ip66
Max shaft load	10 N (1 Kp) axial with shaft $\phi 6$ 20 N (2 Kp) radial with shaft $\phi 6$ 100 N (10 Kp) axial 100 N (10 Kp) radial
Shock	50 G per 11 msec
Vibrations	10G 10 + 2000 Hz
Bearings life	10^9 revolutions
Bearings	n°2 ball bearings
Shaft material	Stainless steel AISI303
Body material	Aluminium -UNI 5076 --58B/C--63A/D/E/G Aluminium -UNI 9002/5 --90A-115A
Cover material	--58B/C--63A/D/E/G Special plastic reinforced with glass fibre --90A--115A Aluminium
Protection	IP54 IP66 optional --58B/C--63A/D/E--90A
Operating Temperature	0° + +60°C
Storage Temperature	-15° + +70°C
Weight	~ 350g --58B/C--63A/D/E/G ~ 750 g --90A--115A
Accessories	N°3 set of fasteners for --63A/B/C--90A models Ordination code : 94080001 





MULTITURN ABSOLUTE ENCODERS EAM PARALLEL - SSI



Description of the PARALLEL multiturn absolute encoder

The EAM range of parallel multiturn absolute encoders was studied for applications requiring high accuracy, also on extended linear development; they are available with resolution levels up to 13 bits and therefore 8192 Positions/Turn on the turn and with resolution levels of up to 12 bits, 4096 Positions/turn for turns. The robust mechanics and the different types of flanging mean that it can be used in a broad range of applications, guaranteeing correct operation, even in the most arduous conditions.

This range of encoders is available with cable or connector output and as for the single turn, they can reach a level of protection up to IP66, depending on the model. The output configurations are both grey code and binary and the output electronics cover all fields of application being available in the NPN, NPN OPEN COLLECTOR, PNP and PUSH PULL formats.

Description of the SSI multiturn absolute encoder

The range of multi-turn absolute encoders with SSI format output, supply the data in this format, created by technology already introduced into the single turn. The use of this standard increases the efficacy of this type of encoder; this is because the amount of data of a multi-turn is much higher and the serial approach becomes an optimum solution to the growing number of wires.

For this series in fact, the output data is formed by a 25 bit word, as the standard in which the useful bits are numerically proportional to the resolution chosen for the encoder.

This type of transmission therefore considerably reduces the wiring problem, while maintaining the device performance the same. In this encoder range, the data connections are reduced, as for the single turn, to just four wires; one pair for the position code and one for the clock signal, both in differential logic. The mechanical components, above all the flanging available are highly diverse and capable of satisfying the most widely ranging demands.

Ordering codes for multiturn absolute encoder

PARALLEL

In case of a particular Customer variant separate by a full stop

EAM 63 A 4096 / 4096 G 8/28 P P X 10 X 3 MA R . XXX

EAM = multiturn absolute encoder

58 = body dimension
63 = body dimension
90 = body dimension
115 = body dimension

A = mod.EAM 63 / 90 / 115
B = mod.EAM58
C = mod.EAM58
D = mod.EAM63 Type of flanges
E = mod.EAM63
F = mod.EAM63
G = mod.EAM63

2 / 4 / 8 / 16 / 32 / 64 / 128 / 256 / 512 / 1024 / 2048 / 4096 Turns

2 / 4 / 8 / 16 / 32 / 64 / 128 / 256 / 512 / 1024 / 2048 / 4096 / 8192 Resolutions

N.B.: For impulse availability contact our offices

B = Binary Code
G = Gray (Standard)

8 ÷ 28 Encoder power supply (Vdc)

P = PUSH PULL with short circuit protection (Standard positive logic) Electronics output configuration
 N.B.: For the optionals on the output configurations contact our offices

XXX = Special Customer variants indicated by a progressive number from 001 to 999

R = radial
A = axial

PD = 16 poles cable
 standard output cable 1.5 m

PE = 32 poles cable
 standard output cable 1.5 m

MA = Connector "MS" type 19 poles

ME = Connector "MS" type 32 poles

3 = 3000 with IP66

R.P.M.

6 = 6000

X = IP54

Protection

S = optional IP66 excluding EAM63G / F - EAM115A

6 = ø 6g6 mm -- 58B
8 = ø 8g6 mm -- 58B -- 63A / D / E -- 90A
9 = ø 9.52g6 mm -- 63 A / D / E -- 90A Shaft diameter
10 = ø 10g6 mm -- 58B / C -- 63A / D / E -- 90A -- 115A
11 = ø 11g6 mm -- 115A

8 = ø 8H7 mm
9 = ø 9H7 mm
10 = ø 10H7 mm
12 = ø 12H7 mm
14 = ø 14H7 mm
15 = ø 15H7 mm

Hole diameter only for mod.63 G / F

L = Latch (only Gray)

Options

X = to indicate if not use

N = Negative

P = Positive

Logics

Output connections for multiturn absolute PARALLEL encoder

FUNCTION	B / G	16 WAY CABLE COLOUR	32 WAY CABLE COLOUR	PIN M19MP	PIN M32MP
bit 1 (LSB)	B ⁰ /G ⁰	green	green	A	A
bit 2	B ¹ /G ¹	yellow	yellow	B	B
bit 3	B ² /G ²	blue	blue	C	C
bit 4	B ³ /G ³	brown	brown	D	D
bit 5	B ⁴ /G ⁴	pink	pink	E	E
bit 6	B ⁵ /G ⁵	white	white	F	F
bit 7	B ⁶ /G ⁶	gray	Gray	G	G
bit 8	B ⁷ /G ⁷	violet	violet	H	H
bit 9	B ⁸ /G ⁸	gray/pink	gray/pink	J	J
bit 10	B ⁹ /G ⁹	white/green	white/green	K	K
bit 11	B ¹⁰ /G ¹⁰	brown/green	brown/green	L	L
bit 12	B ¹¹ /G ¹¹	white/yellow	white/yellow	M	M
bit 13	B ¹² /G ¹²	Yellow/brown	yellow/brown	N	N
bit 14	B ¹³ /G ¹³	/	White/gray	P	P
bit 15	B ¹⁴ /G ¹⁴	/	gray/brown	R	R
bit 16	B ¹⁵ /G ¹⁵	/	white/pink	S	S
bit 17	B ¹⁶ /G ¹⁶	/	pink/brown	/	T
bit 18	B ¹⁷ /G ¹⁷	/	white/blue	/	U
bit 19	B ¹⁸ /G ¹⁸	/	brown/blue	/	V
bit 20	B ¹⁹ /G ¹⁹	/	white/red	/	W
bit 21	B ²⁰ /G ²⁰	/	brown/red	/	X
bit 22	B ²¹ /G ²¹	/	white/black	/	Y
bit 23	B ²² /G ²²	/	brown/black	/	Z
bit 24	B ²³ /G ²³	/	gray/green	/	a
bit 25	B ²⁴ /G ²⁴	/	yellow/pink	/	d
LATCH	/	/	yellow/gray	/	e
/	/	/	/	/	f
0 Volt	/	black	black	T	j
U / D	/	red/blue	red/blue	U	g
+ Vdc	/	red	red	V	h

Connector or cable choice

According to the resolution on turn and to the turns number chose is possible to calculate the necessary connections of the connector or of the cable to use.

From the table below is possible to get the connections number:

Resolutions on turn + Turns number:

Resolution / N° Turns	Bit Number	Connections Number
2	1	1
4	2	2
8	3	3
16	4	4
32	5	5
64	6	6
90 128	7	7
180 / 225 / 250 256	8	8
360 / 450 / 500 512	9	9
720 / 900 / 1000 1024	10	10
1440 / 1800 / 2000 2048	11	11
2880 / 3600 / 4000 4096	12	12
8192	13	13

EXAMPLE 1 :

Resolutions/Turn 256 = 8 connections

N° Turns 32 = 5 connections

Total connections 13.

EXAMPLE 2 :

Resolutions/Turn 4096 = 12 connections

N° Turns 4096 = 12 connections

Total connections 24.

From 1 to 13 connections to consider 16 poles cable or 19 poles connector.

From 14 to 25 connections to consider 32 poles cable or 32 poles connector.

Ordering codes for multiturn absolute encoder

SSI

In case of a particular Customer variant separate by a full stop

EAM 63 A 4096 / 4096 G 5 S X X 10 X 3 MC R . XXX

EAM = multiturn absolute encoder

58 = body dimension
63 = body dimension
90 = body dimension
115 = body dimension

A = mod.EAM 63 / 90 / 115
B = mod.EAM58
C = mod.EAM58
D = mod.EAM63 **Type of flanges**
E = mod.EAM63
F = mod.EAM63
G = mod.EAM63

2 / 4 / 8 / 16 / 32 / 64 / 128 / 256 / 512 / 1024 / 2048 / 4096 **Turns**

2 / 4 / 8 / 16 / 32 / 64 / 128 / 256 / 512 / 1024 / 2048 / 4096 / 8192 **Resolutions**
 N.B.: For impulse availability contact our offices

B = Binary **Code**
G = Gray (Standard)

5 **Encoder power supply (Vdc)**
8 ÷ 28

S = SSI (Serial Synchronous Interface) **Electronics output configuration**
 N.B.: For the optionals on the output configurations contact our offices

XXX = Particular Customer variants indicated by a progressive number from 001 to 999

R = radial
A = axial

PC = 12 poles cable standard output cable 1.5 m
MC = Connector "MS" type 7 poles
HA = Connector 12 poles

3 = 3000 with IP66 **R.P.M.**
6 = 6000

X = IP54 **Protection**
S = optional IP66 excluding EAM63G / F - EAM115A

6 = ø 6g6 mm -- 58B
8 = ø 8g6 mm -- 58B -- 63A / D / E -- 90A
9 = ø 9.52g6 mm -- 63A / D / E -- 90A **Shaft diameter**
10 = ø 10g6 mm -- 58B / C -- 63A / D / E -- 90A -- 115A
11 = ø 11g6 mm -- 115A

8 = ø 8H7 mm
9 = ø 9.52H7 mm
10 = ø 10H7 mm
12 = ø 12H7 mm
14 = ø 14H7 mm
15 = ø 15H7 mm **Hole diameter only for mod.63 F / G**

X = not to utilize **Options**

X = not to utilize **Logics**

Output connections for multiturn absolute SSI encoder

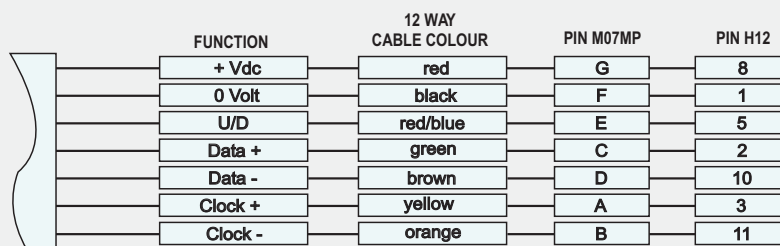

EAM63A

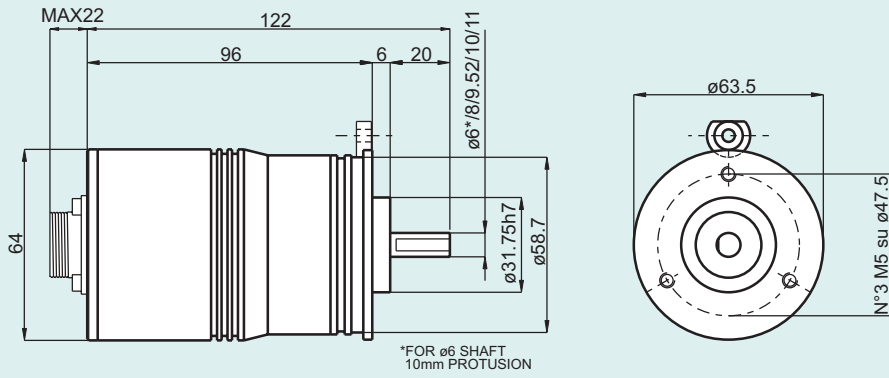

EAM58B

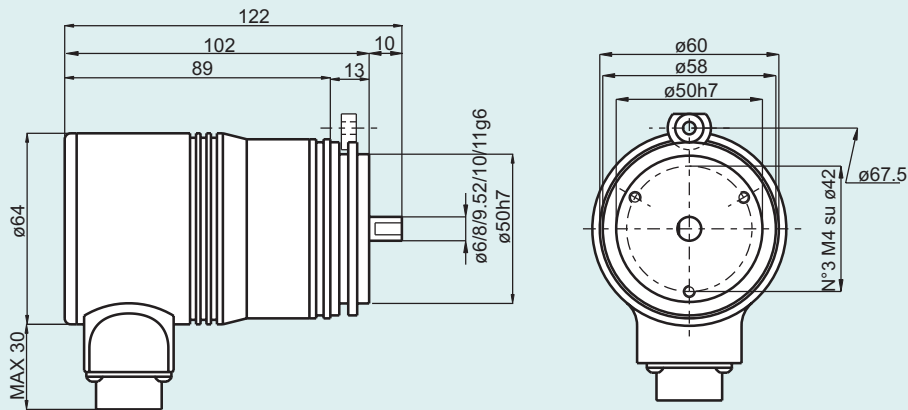

EAM58C

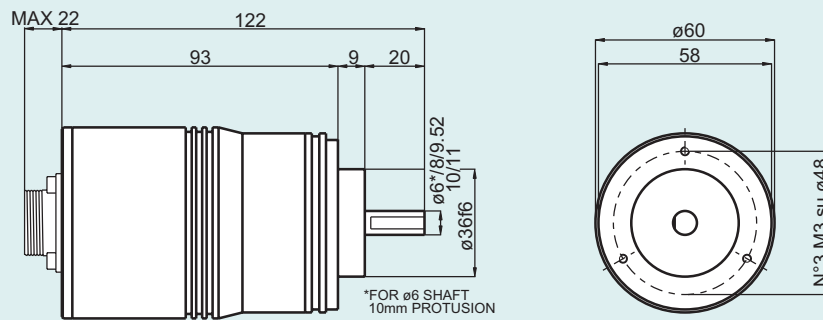

EAM63D - EAM63E

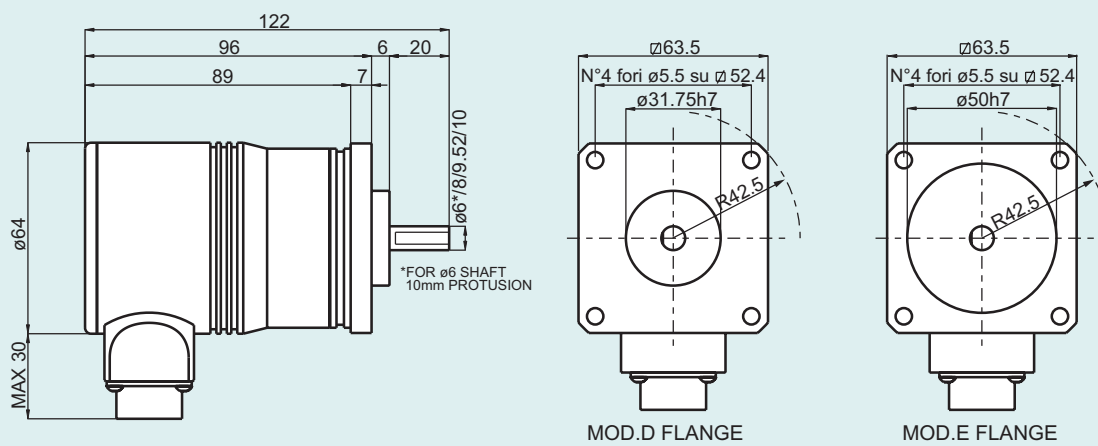

EAM63F - EAM63G

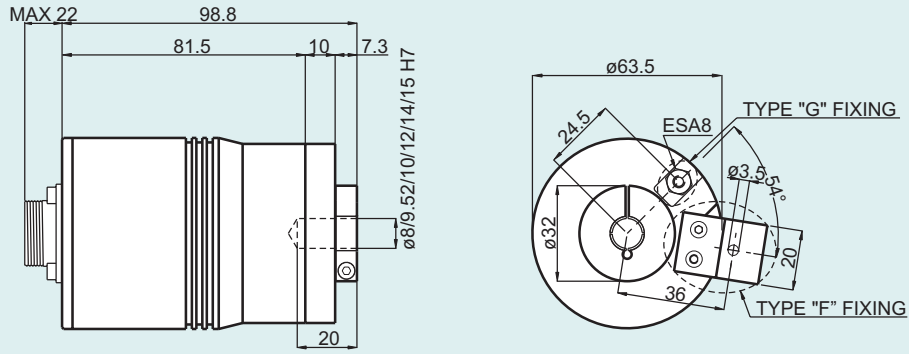

EAM90A

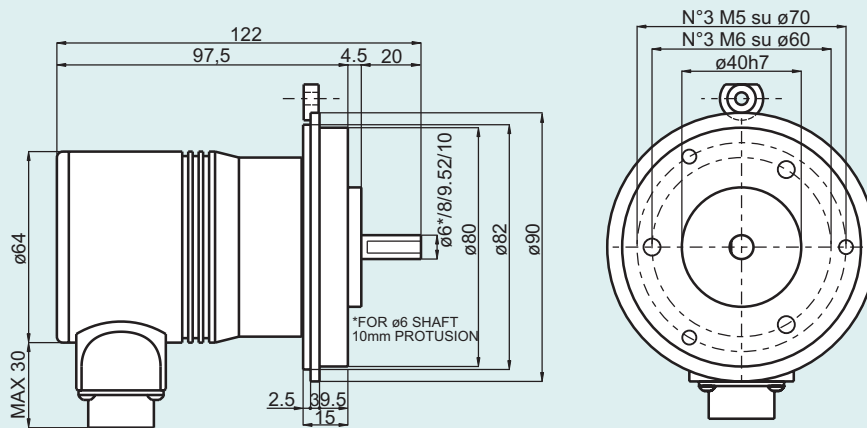

EAM115A

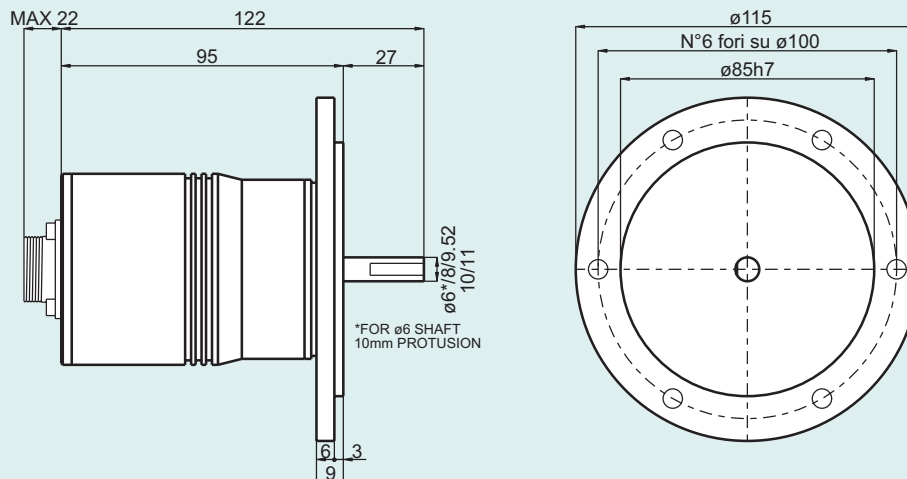

Environmental Characteristics	
Protection	IP54 IP66 optional --58B/C --63A/D/E --90A
Operating Temperature	0° + +60°C
Storage Temperature	-15° + +70°C

Mechanical Characteristics	
Shaft diameters (mm)	ø6 g6 -- 58B ø8 g6 -- 58B -- 63A/D/E -- 90A ø9.52(3/8") g6 -- 63A/D/E -- 90A ø10 g6 -- 58B/C -- 63A/D/E -- 90A -- 115A ø11 g6 -- 115A
Hole diameters (mm)	ø8 H7 --63F/G ø9 H7 --63F/G ø10 H7 --63F/G ø12 H7 --63F/G ø14 H7 --63F/G ø15 H7 --63F/G
R.P.M. Max	6000 continuous 3000 continuous for --63F/G 3000 with IP66
Max shaft load	10 N (1 Kp) axial with shaft ø6 20 N (2 Kp) radial with shaft ø6 100 N (10 Kp) axial 100 N (10 Kp) radial
Shock	50 G per 11 msec
Vibrations	10G 10 + 2000 Hz
Bearings life	10 ⁹ revolutions
Bearings	n°2 ball bearings
Shaft material	Stainless steel AISI303
Body material	Aluminium -UNI 9002/5- (D11S)
Cover material	Aluminium alloy 6060
Flange material	Aluminium -UNI 9002/5- (D11S)
Weight	~ 600 g --58B/C--63A/D/E/F/G ~ 800 g --90A--115A

Electronic Characteristics PARALLEL	
Turns	2 / 4 / 8 / 16 / 32 / 64 / 128 / 256 / 512 / 1024 / 2048 / 4096
Resolutions / Turn	2 / 4 / 8 / 16 / 32 / 64 / 128 / 256 / 512 / 1024 / 2048 / 4096 / 8192
Power supply	8 ± 28 Vdc
Current consumption without load	150 mA
Max commutable current	40 mA per channel
Electronic output configuration	PUSH PULL (positive logic)
Max output frequency	100 KHz output code $F = \frac{\text{RPM} \times \text{Resolution}}{60}$
Accuracy	+/- 1/2 LSB

Electronic Characteristics SSI	
Turns	2 / 4 / 8 / 16 / 32 / 64 / 128 / 256 / 512 / 1024 / 2048 / 4096
Resolutions / Turn	2 / 4 / 8 / 16 / 32 / 64 / 128 / 256 / 512 / 1024 / 2048 / 4096 / 8192
Power supply	5 Vdc / 8 ± 28 Vdc
Current consumption without load	150 mA
Electronic output configuration	SSI (Serial Synchronous Interface)
Monostable time	10 - 25 µs
Time between two clock sequences	> 35 µs
Frequency range	100 KHz - 1 MHz
Accuracy	+/- 1/2 LSB



MULTITURN ABSOLUTE ENCODER EAM PROFIBUS



Presentation

The Eltra multi-rotation Profibus encoder (Identification Number 0x0599) conforms to the standard Profibus DP described in the European Standard EN 50170 Volume 2 and in particular to the profile established for encoders "PROFIBUS Profile for Encoders, Order No. 3.062". The version with the Profibus DP interface keeps the same maximum resolution characteristics (8092 Pos/turn and 4096 revolutions) and efficiency characteristics of the stand-alone version, but adds the potential and flexibility typical of the Profibus DP network.

Via the Profibus DP network it is therefore possible to:

- Obtain the indication of the angular position from the encoder, during the *cyclical data exchange*
- Set the resolution on the turn and on the revolutions (during parameterizing)
- Change the predefined count increase direction (again during parameterizing)
- Perform the PRESET operation; in other words to set the encoder indication to a certain quota
- Read the operating diagnostic
- Have indications about the code supplied by the device.

On the device at a local it is also possible to:

- Display the ON/OFF status
- Display the device activity on the bus
- Give a RESET, in other words to set the current encoder code to 0
- Set the device address
- Insert the termination resistances on the bus, if needed
- Invert the count direction

Device hardware installation

Installing the Eltra profibus encoder in a network requires the execution of the typical operations necessary for setting up any Profibus DP slave; the sequence of the steps can be summarised thus:

- 1 - *Commissioning* the slave on the master (see corresponding paragraph).
- 2 - Wiring the encoder into the Profibus network, with the insertion or not of terminations depending on the physical position the device occupies on the bus.
- 3 - Locally setting the address (which must be unique in the network and the same as the one chosen in point 1) for the slave.
- 4 - Preparing the master side application/s and setting up the Profibus network.

As we can see from the rear view of the encoder (see figure to the side) there is a led inspection window on the cover and a plug allowing access to the device local settings. The device operating status can be seen through the window by the two leds present. In particular, the green led signals power supply presence and must be permanently on, whilst the red led only goes out during the cyclical data exchange between the Profibus master that parameterized the encoder and the encoder itself.

In the cut-away alongside, we can see the RESET button, or better the button for zeroing the code of the two dip-switches for line termination and the eight dip-switches for choosing the device address only to be used with the encoder at a standstill.

In the particular configuration shown in the cited figure, the two line termination contacts are in the OFF status and do not therefore foresee bus termination on the encoder.

Of the eight dip-switches available only the first seven are used for the slave address, given that the maximum number of devices that can be inserted in a Profibus network is 126 elements. Also, we must consider that contact 1 is the LSB of the address code, whilst contact 7 is the MSB. The eighth switch on the other hand is used for code inversion.



REAR COVER VIEW



CUT-AWAY DRAWING

CONNECTION TO THE NETWORK.

Concerning encoder connection to the Profibus DP network, cable access inside the device is through three skintops (only two can be used if preferred).

Usually, one is used for connection to the bus, one for network continuity connection and the last, optional, for local encoder power supply (if this is not distributed via the network and the RS-485 twin wire connection).



ACCESS TO THE TERMINAL BLOCK

To access the terminal block, unscrew the two screws on the rear plug and release the rear case from the main one by sliding it out from the sunken connector. Now connect the cables following the serigraphy on the connector, summarised in the following table:

+V	SUPPLY VOLTAGE
0V	GROUND
B	PROFIBUS DP LINE OUT (RED)
A	PROFIBUS DP LINE OUT (GREEN)
B	PROFIBUS DP LINE IN (RED)
A	PROFIBUS DP LINE IN (GREEN)
+5V	DC ISOLATED
GND	DC ISOLATED
RTS	REQUEST TO SEND

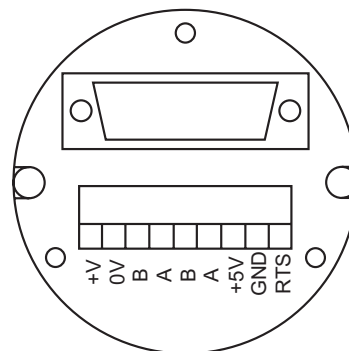

N.B.: To parameterize and configure the slave onto the Profibus DP master (*Commissioning* operation) it is necessary to use the “Exx_0599.gsd “ file supplied with the encoder and in any case available at the following site:www.eltra.it.

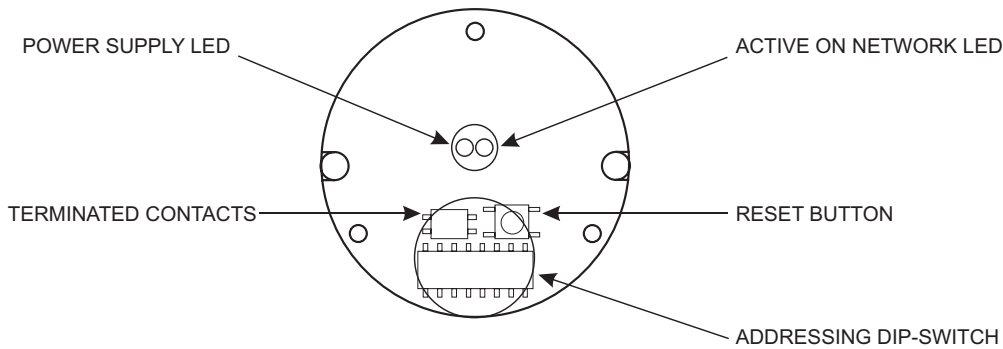

SETTING THE DIP-SWITCHES

Below, we give examples of profibus line closing and device setting, plus the standard position of the address dip-switches.



STANDARD SETTING

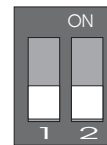

STANDARD SETTING

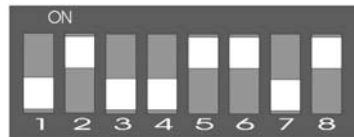

In this example a device LINE CLOSING address has been set equal to 1001101 from bit 2 to bit 8, corresponding to hexadecimal 77, whilst the first (1) bit corresponds to code inversion, which in this case is active.



LINE CLOSING

NETWORK CHARACTERISTICS:

The physical means usually adopted when constructing a DP/FMS network is cable type A, which must have the following characteristics:

Parameter	Cable type A
Characteristic impedance in Ω	135 ... 165 at a frequency of (3...20 Mhz)
Operating capacity (pF/m)	< 30
Loop resistance (Ω /km)	<=110
Core diameter (mm)	>0.64 *)
Core cross-section (mm ²)	>0.34 *)

This cable permits optimum network utilisation. In other words, it is possible to reach the maximum permitted communication speed of 12 Mbaud. There are however the following limitations to the maximum physical dimensions of a bus segment:

Baud rate (kbit/s)	9.6	19.2	93.75	187.5	500	1500	12000
Range/Segment	1200 m	1200 m	1200 m	1000 m	400 m	200 m	100 m

Finally, we recall the physical and topographical characteristics of a profibus network:

Maximum number of stations participating in the exchange of user data	DP: 126 (address from 0..125) FMS: 127 (address from 0..126)
Maximum number of stations per segment including repeaters	32
Available data transfer rates in kbit/s	9.6, 19.2, 45.45, 93.75, 187.5, 500, 1500, 3000, 6000, 12000
Max. number of segments in series	According to EN 50170, a maximum of 4 repeaters are allowed between any two stations. Dependent on the repeater type and manufacturer, more than 4 repeaters are allowed in some cases. Refer to the manufacturer's technical specification for details.

Ordering codes for multiturn absolute encoder

PROFIBUS

In case of a particular Customer variant separate by a full stop

EAM 63 A 4096 / 4096 B12/28 F X X 10 X 3 P3 R . XXX

EAM = multiturn absolute encoder

58 = body dimension
63 = body dimension
90 = body dimension
115 = body dimension

A = mod.EAM63 / 90 / 115
B = mod.EAM58
C = mod.EAM58
D = mod.EAM63 Type of flanges
E = mod.EAM63
F = mod.EAM63
G = mod.EAM63

2 / 4 / 8 / 16 / 32 / 64 / 128 / 256 / 512 / 1024 / 2048 / 4096 Turns

2 / 4 / 8 / 16 / 32 / 64 / 128 / 256 / 512 / 1024 / 2048 / 4096 / 8192 Resolutions
 N.B.: For impulse availability contact our offices

B = Binary Code

12 ÷ 28 Encoder power supply (Vdc)

F = PROFIBUS Electronics output configuration
 N.B.: For the optionals on the output configurations contact our offices

XXX = Special Customer variants indicated by a progressive number from 001 to 999

R = radial

P2 = two skintop
P3 = three skintop

3 = 3000 with IP66 R.P.M.
6 = 6000

X = IP54 Protection
S = optional IP66 excluding EA63F/G --EAM115

6 = ø 6g6 mm -- 58B
8 = ø 8g6 mm -- 58B -- 63A / D / E -- 90A
9 = ø 9.52g6 mm -- 63A / D / E -- 90A Shaft diameter
10 = ø 10g6 mm -- 58B / C -- 63A / D / E -- 90A -- 115A
11 = ø 11g6 mm -- 115A

8 = ø 8H7 mm
9 = ø 9H7 mm
10 = ø 10H7 mm
12 = ø 12H7 mm
14 = ø 14H7 mm
15 = ø 15H7 mm
Hole diameter only for mod.63F / G

X = not to utilize Options

X = not to utilize Logics

Enviromental Characteristics

Protection	IP54 IP66 optional --58B/C --63A/D/E --90A
Operating Temperature	0° + +60°C
Storage Temperature	-15° + +70°C

Mechanical Characteristics

Shaft diameters (mm)	ø6 g6 -- 58B ø8 g6 -- 58B -- 63A/D/E -- 90A ø9.52(3/8") g6 -- 63A/D/E -- 90A ø10 g6 -- 58B/C -- 63A/D/E -- 90A -- 115A ø11 g6 -- 115A
Hole diameters (mm)	ø8 H7 --63F/G ø9 H7 --63F/G ø10 H7 --63F/G ø12 H7 --63F/G ø14 H7 --63F/G ø15 H7 --63F/G
R.P.M. Max	6000 continuos 3000 continuos for --63G/F 3000 with Ip66
Shock	50 G per 11 msec
Vibrations	10G 10 + 2000 Hz
Bearings life	10 ⁹ revolutions
Bearings	n°2 ball bearings
Shaft material	Stainless steel AISI303
Body material	Aluminium -UNI 9002/5- (D11S)
Cover material	Aluminium alloy 6060
Flange material	Aluminium -UNI 9002/5- (D11S)
Weight	~ 800 g --58B/C--63A/D/E/F/G ~ 1000 g --90A--115A

Electronic Characteristics

Turns	2 / 4 / 8 / 16 / 32 / 64 / 128 / 256 / 512 / 1024 / 2048 / 4096
Resolutions	2 / 4 / 8 / 16 / 32 / 64 / 128 / 256 / 512 / 1024 / 2048 / 4096 / 8192
Power supply	12 ÷ 28 Vdc
Current consumption without load	300 mA
Electronic of Bus	LINE DRIVER (RS485)
Max output frequency	100 KHz output code F = $\frac{\text{RPM} \times \text{Resolution}}{60}$
Accuracy	+/- 1/2 LSB
Bus Max Frequency	12 Mbaud

EAM63A

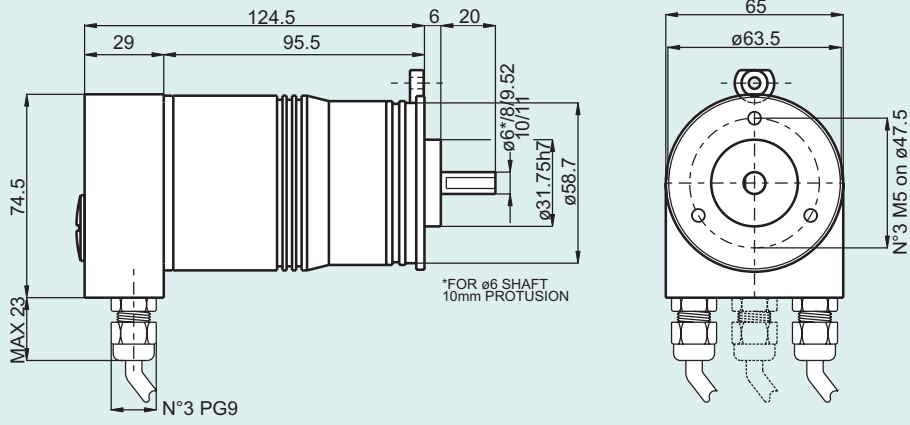

EAM58B

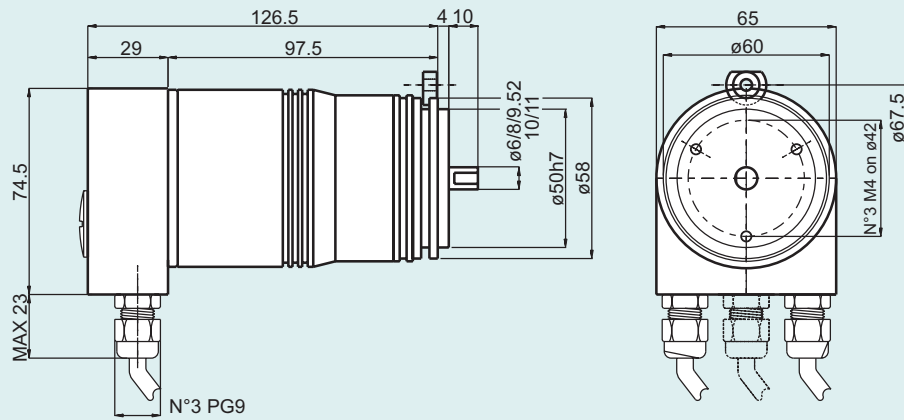

EAM58C

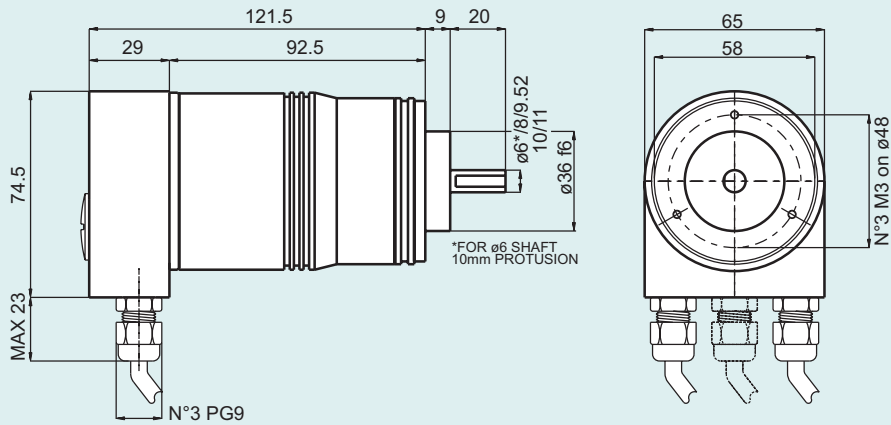

EAM63D - EAM63E

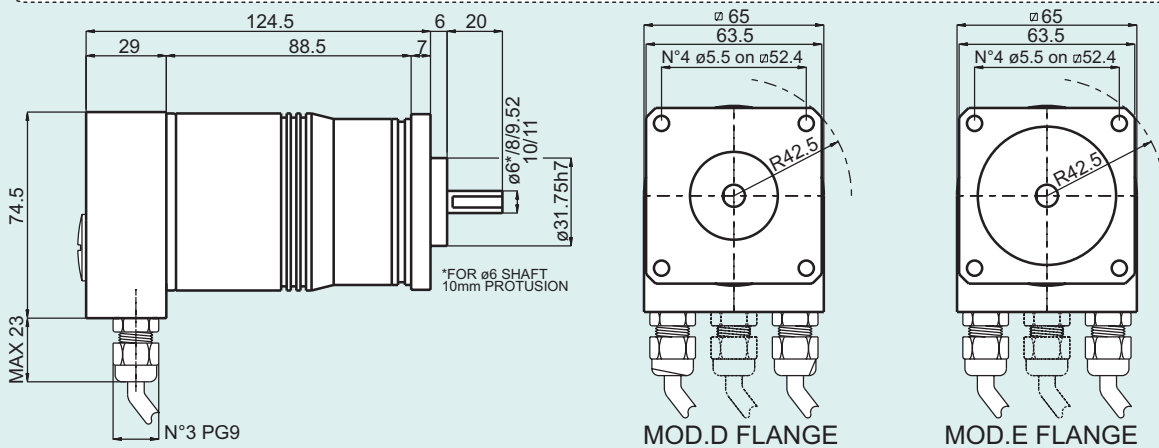

EAM63F - EAM63G

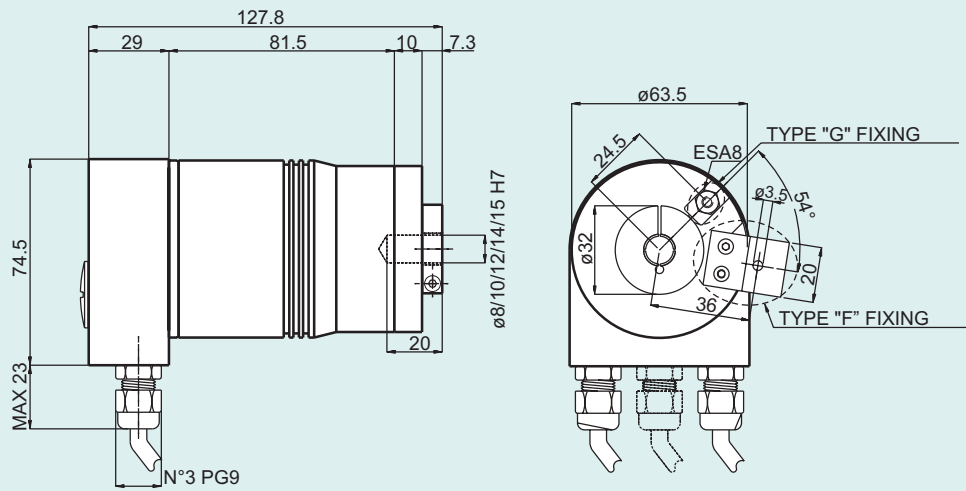

EAM90A

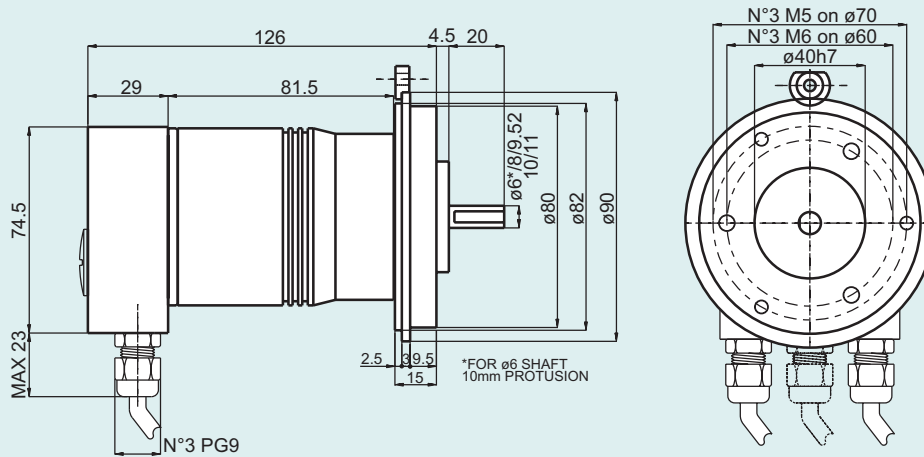

EAM115A

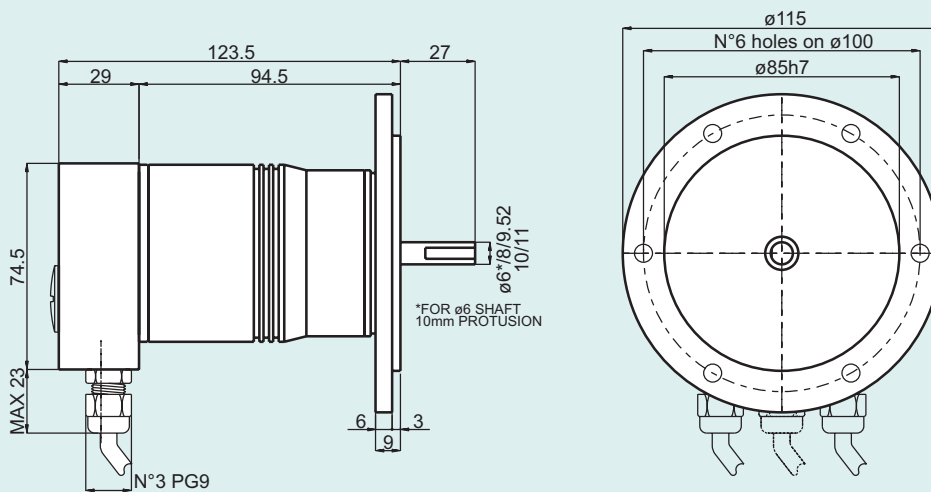



EA40T / U

SINGLETURN ABSOLUTE ENCODER FOR TOOL CHANGE TURRETS

Absolute Encoders

The encoders of the 40T/U models found their applications in the field of machine tools and are specifically suitable for being assembled on turrets for tool change (8 or 12 position).

It is interesting to note the timing system between encoder and turret through an led situated on the cover, that visualizes the position of the first tool making the assembly easy and quick for the operator.

The main characteristics are:

- easy assembly
- protection IP66
- different electronic configuration with power supply up to 24 Vdc
- turret configuration at 8 and 12 position turn.



Ordering codes

EA 40 T 12 B 8/28 R P 6 S 3 P R . XXX

In case of particular Customer variant separate by a full stop

EA = singleturn absolute encoder

40 = body dimension

T = mod.EA40T
U = mod.EA40U
Type of flanges

8
12
Turn position

B = binary
Code

5
8 ÷ 28
Encoder power supply (Vdc)

N = NPN
C = NPN OPEN COLLECTOR
R = PNP
U = PNP OPEN COLLECTOR
Electronics output configuration

XXX = Particular Customer variants indicated by a progressive number from 001 to 999

R = radial

P = output cable (standard length 0.5 m)

3 = 3000 max
R.P.M.

S = standard IP66
Protection

6 = ø6 mm
Shaft diameter

N = negative
P = positive
Logics

EA40T

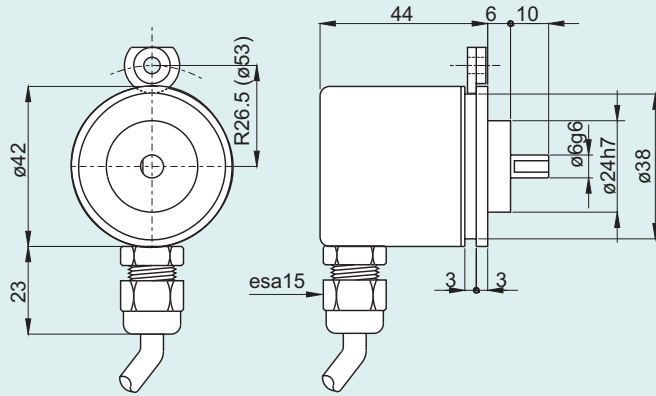

EA40U

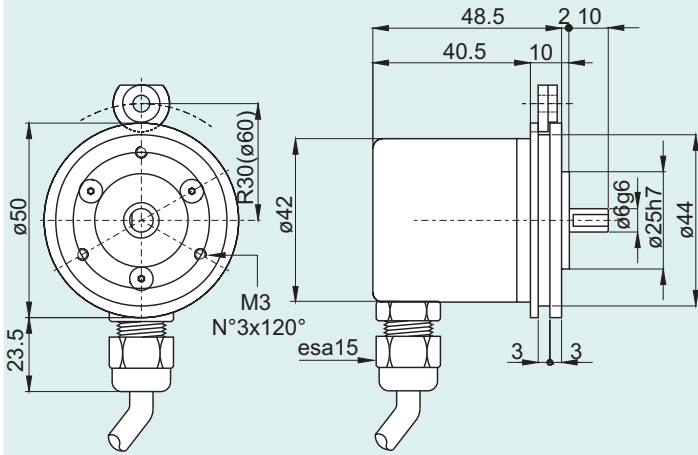

Electronic Characteristics

Turn position	8 / 12
Power supply	5 Vdc / 8 + 28 Vdc
Current consumption without load	100 mA
Max commutable current	40 mA per channel
Electronic output configuration	NPN / NPN OPEN COLLECTOR / PNP / PNP OPEN COLLECTOR
Max output frequency	100 KHz output code

Mechanical Characteristics

Shaft diameter (mm)	ø6 g6
Protection	IP66 - Standard
R.P.M. Max	3000 continuous
Max shaft load	5N (0.5 Kp) axial 5N (0.5 Kp) radial
Shock	50 G per 11 msec
Vibrations	10G 10 ÷ 2000 Hz
Bearings life	10 ⁹ revolutions
Bearings	n°2 ball bearings
Shaft material	Stainless steel AISI303
Body material	Aluminium D11S - UNI 9002/5
Cover material	Special plastic reinforced with glass fibre
Operating Temperature	0° + +60°C
Storage Temperature	-15° + +70°C
Weight	100 g

Output signal configuration

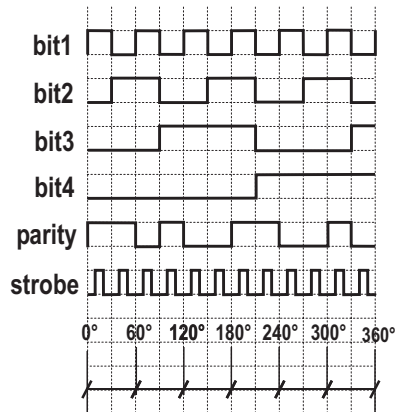

Cable colour	WHITE	YELLOW	GREEN	VIOLET	RED	BLACK	BROWN	BLUE
Turn position	bit1	bit2	bit3	bit4	Parity	Strobe	+ Vdc	0 Volt
1	•				•	⌋		
2		•			•	⌋		
3	•	•				⌋		
4			•		•	⌋		
5	•		•			⌋		
6		•	•			⌋		
7	•	•	•		•	⌋		
8				•	•	⌋		
9	•			•		⌋		
10		•		•		⌋		
11	•	•		•	•	⌋		
12			•	•		⌋		





EAX80A / D

FLAMEPROOF SINGLETURN ABSOLUTE ENCODER

Absolute Encoders

Flameproof encoders for applications within explosive and dangerous areas.

- Resolutions up to 8192 imp/turn (13 bit).
- Different electronic configurations available with a power supply up to 28 Vdc.
- Output cable.
- Different flanges available.
- Speed rotation up to 3000 rpm.
- Protection up to IP64.



Ordering codes

EAX 80 A 512 G 5 N N X 10 X 3 P R . XXX

In case of a particular Customer variant separate by a full stop

EAX = flameproof
singleturn absolute

80 = body dimension

A = mod.EAX80A
D = mod.EAX80D **Type of flanges**

2 / 4 / 8 / 16 / 32 / 64 /
128 / 256 / 512 / 1024 /
2048 / 4096 / 8192
90 / 180 / 360 / 720 /
1440 / 2880
225 / 450 / 900 / 1800 / 3600
250 / 500 / 1000 / 2000 / 4000
Resolutions
N.B.: For impulse availability contact our offices

B = Binary
G = Gray (standard) **Code**
N.B.: For the compensated code of binary encoder (0-XXX) contact the Technical office

5
8 ÷ 28 **Encoder power supply (Vdc)**

N = NPN (Standard negative logic)
C = NPN OPEN COLLECTOR (Standard negative logic)
R = PNP (Standard positive logic) **Electronics output configuration**
U = PNP OPEN COLLECTOR (Standard positive logic)
P = PUSH PULL with short circuit protection (Standard positive logic)
S = SSI (Serial Synchronous Interface)
N.B.: For the optionals on the output configurations contact our offices

XXX = Particular Customer variants indicated by a progressive number from 001 to 999

R = radial

P = standard output cable 1.5 m
G = threaded union 1/2" Gas

3 = 3000 **R.P.M.**

X = IP64 **Protection**

10 = ø10 g6 mm **Shaft diameter**

L = Latch
S = Strobe to indicate only with binary code **Options**
X = indicate if output SSI

N = Negative
P = Positive **Logics**
X = indicate if output SSI

EAX80A

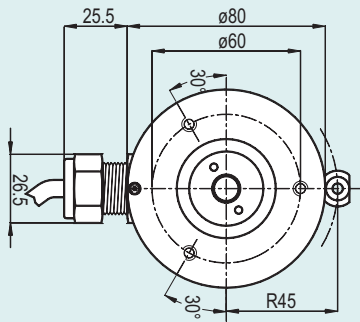
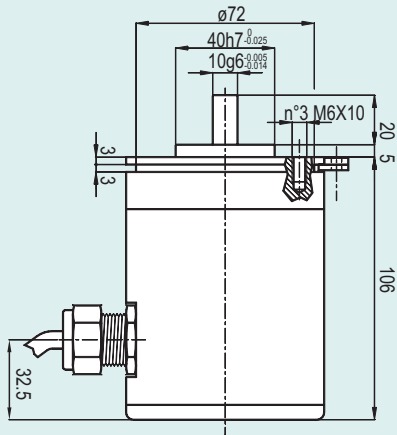

EAX80D

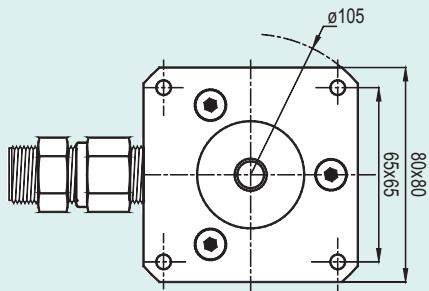
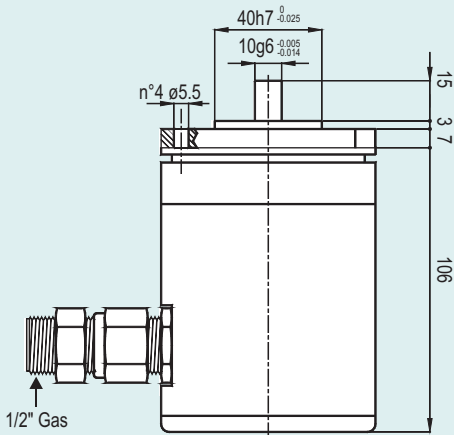

Electronic Characteristics

Resolution	2 / 4 / 8 / 16 / 32 / 64 / 128 / 256 / 512 / 1024 / 2048 / 4096 / 8192 90 / 180 / 360 / 720 / 1440 / 2880 225 / 450 / 900 / 1800 / 3600 250 / 500 / 1000 / 2000 / 4000
Power supply	5 Vdc / 8 + 28 Vdc
Current consumption without load	100 mA
Max commutable current	50 mA per channel
Electronic output configuration	NPN (negative logic) NPN Open Collector (negative logic) PNP (positive logic) PNP Open Collector (positive logic) PUSH PULL (positive logic) SSI (Serial Synchronous Interface)
Max output frequency	100 KHz output code $F = \frac{\text{RPM} \times \text{Resolution}}{60}$

Mechanical Characteristics

Shaft diameter (mm)	ø10 g6
R.P.M. Max	3000
Shock	50 G per 11 msec
Vibrations	10G 10 + 2000 Hz
Max shaft load	200 N (20 Kp) axial 200 N (20 Kp) radial
Bearings life	10 ⁹ revolutions
Bearings	n°2 ball bearings
Shaft material	Stainless steel AISI303
Body material	Aluminium D11S - UNI 9002/5
Operating Temperature	0° + +60°C
Storage Temperature	-15° + +70°C
Weight	1200 g

Flameproof encoders at EExdIIC T6 standard



EN 50.014 / EN 50.018
CESI certified number: EX-97.D.015

Eexd IIC T6

EEx: electrical system for explosive and dangerous areas.

d: anti explosion box.

I: electrical system which can operate in dangerous areas except for the mines where "grisou" gas is present.

C: type of protection based on the special interstice designed to have the maximum security on the flameproof encoder (MESG).
C= maximum security

T6: maximum encoder surface temperature 85°C.

AS006GE0803A



Standard connectors for ABSOLUTE encoders

M07MP

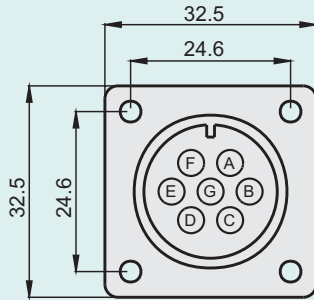

M07FV

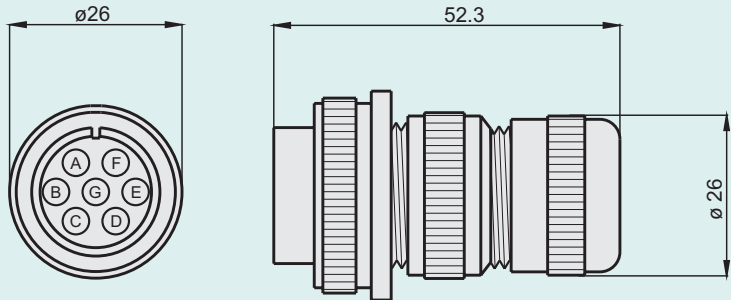

H12MP

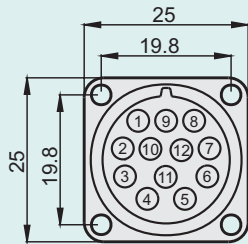

H12FV

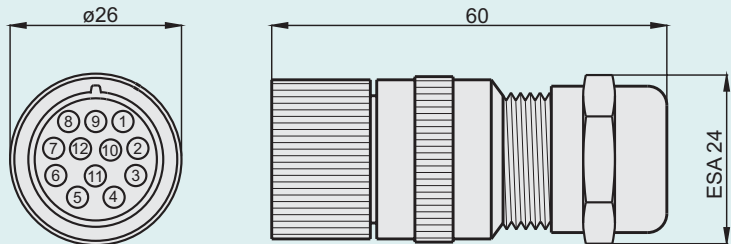

M19MP

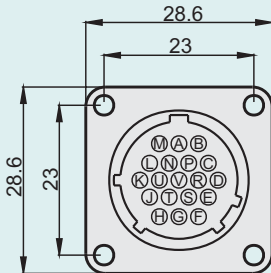

M19FV

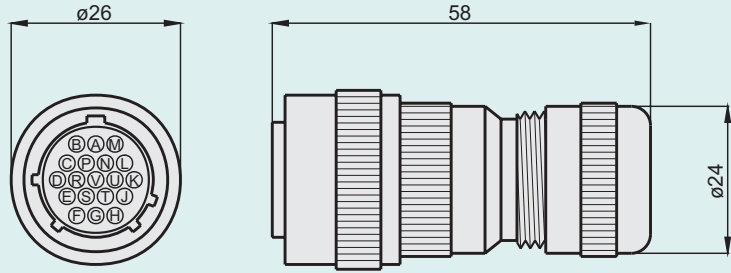

M32MP

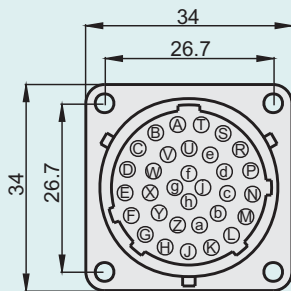

M32FV

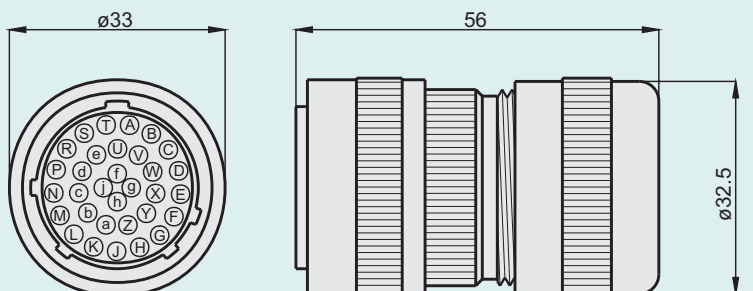

NPN and NPN OPEN COLLECTOR electronics

It is composed of an only transistor of npn type and of resistor of pull-up configuration, which fixes the output voltage to that of power supply when the transistor is in the quiescent position. It is circuitly similar to the logics of TTL type and for this reason is considered to be compatible to them. When it is used correctly it shows low levels of saturations towards the 0 Vdc and practically null towards the positive. The manner is influenced in proportional way by the increase of the cable length, by the frequency of impulses to be transmitted and by the increase of the load, thus the ideal application should keep these considerations in mind. The open collector variant is different for the lack of the pull-up resistor, freeing, in such way, the transistor collector from the tie of the encoder power supply, allowing to obtain output signals with different voltage.

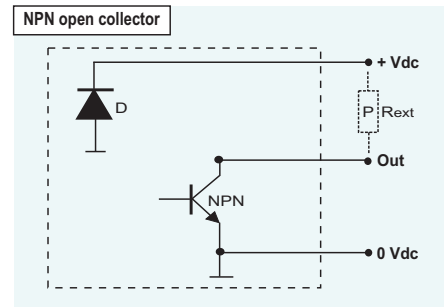
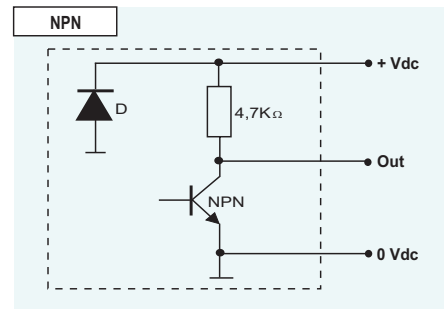

PNP and PNP OPEN COLLECTOR electronics

The most important considerations are the same carried out for the npn electronics. The main differences are in the transistor, which is of pnp type and is constrained to the positive; the resistor, if present, is of the pull-down type connected, therefore, between the output and the zero volt.

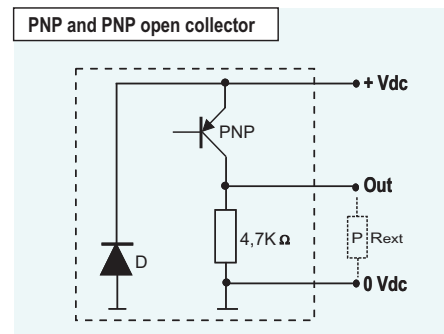

PUSH-PULL electronics

It is used to increase the performance with respect to preceding electronics. Infact the major limitations of the npn or pnp electronics, can depend on the use of the resistor which presents a much higher impedance than a transistor in closing. To overcome these inconveniences in the push-pull type electronics, another transistor of a complimentary is inserted, so that the output is of low impedance, for commutations whether towards the positive or towards zero. This solutions increases the frequency performance, favouring long connections and optimal data transmission, even at high velocities. The levels of signal saturation are contained, but sometimes higher, in comparison to the preceding logics. The push-pull electronics is, in any case, indifferently applicable also to receivers for npn or pnp electronics.

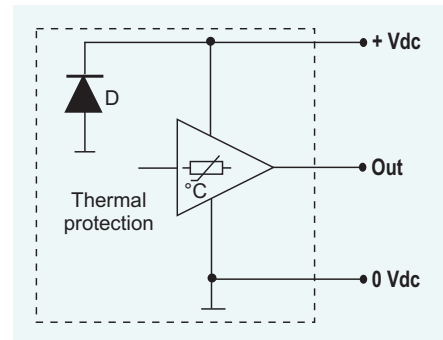

LINE DRIVER electronics

It is used when the operative environments is particularly subjected to electrical disturbances or in presence of high distances between the encoder and the reception system. The transmission and the reception of the data happens on two complementary channels, so the disturbances are limited (the disturbances are caused to cables or adjacent apparatus); these interferences are know as "common way disturbances", as their generation is refered to a common point, which is the mass of the system. The transmission and reception in line driver, instead, happens in a "differential" way, or rather from the differences of the voltages present on the complementary channels of transmission and, therefore, it is insensitive to common way disturbances. This type of transmission is used in 5 Vdc systems and is also known as RS422 compatible, further more power supplies up to 24 Vdc are available where the hard conditions of use need them (long cables, elevated disturbances, etc.).

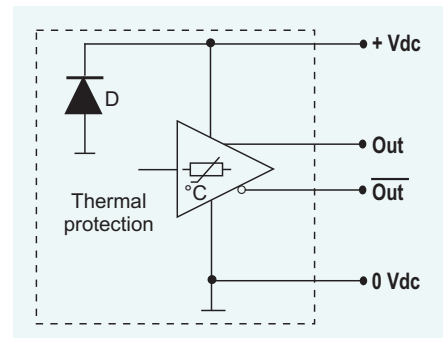

PRECAUTIONS AGAINST ELECTROSTATIC DISCHARGES

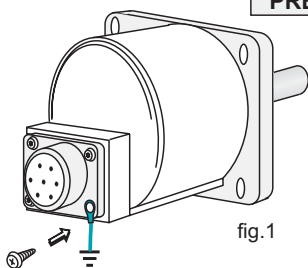

fig.1

Connection of the metallic connector casing to the group through a ring fixed to the screw of the connector itself. (Fig.1)

For a better protection of the electronics against the electrostatic discharges connect the metallic connector casing to the ground.

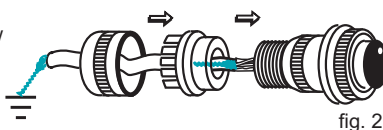

fig. 2

Connection of the braided wire and of the casing of the connector to the ground. (Fig.2)

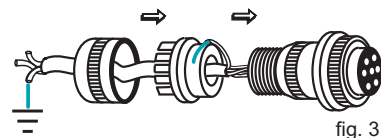

fig. 3

Connection to the ground of the continuity wire and of the connector casing. (Fig.3)





INSTALLATION AND OPERATION PRECAUTIONS

Installation and operation precautions

	The encoder must be used with respect for its qualifications, which are defined as an impulse generator and not as a safety device.
	The personnel assigned to assembling and installing the device must be qualified and follow the instructions in the technical manual.
	The personnel assigned to assembling and installing the device must be qualified and follow the instructions in the technical manual.
	Make sure that the mechanical coupling of the encoder shaft is made with the appropriate elastic joints, especially in the case of accentuated axial or radial movements.
	Make sure that the environment of use is free of corrosive agents (acids, etc.) or, at any rate, substances that are not compatible with the device's mechanical characteristics. In addition, the IP protection grade must be appropriate for the environment of use.
	Verify the ground connection of the device's body, in the event that it is not possible to provide for an additional external connection.
	Before putting it into operation, verify the voltage range applicable to the device, protecting it from exceeding the stated technical specifications.
	Install the power supply and signal cables in such a way as to avoid capacitive or inductive interference that could cause the device to malfunction and far from power lines.
	The wiring of the cables must be carried out in a POWER-OFF condition.
	We recommend that you absolutely avoid making mechanical or electrical modifications for safety reasons and because they will void the warranty.

Principal product warranty conditions

Replacements or repairs whether under the warranty or at the customer's expense must be performed in the service department of Eltra S.r.l. or by explicitly authorized personnel. Before sending material for repair, you must obtain an RGA number from our sales office. During the repair process in our service department, Eltra S.r.l. will be authorized to remove all parts that the customer added to the product.

Any malfunctions due to a failure to observe these usage and installation precautions will lead to the voiding of the warranty.

Repairs will not extend the product warranty. We also exclude compensation for any type of damage or injury due to the use, or suspension of use, of the transducer.

Note: For additional information, we refer you to the Conditions of Sale that can be consulted on our web site, www.eltra.it or requested from our office.



... in the world

- ARGENTINA
- AUSTRALIA
- BRAZIL
- CHILE
- CHINA
- EGYPT
- HONG KONG
- INDIA
- ISRAEL
- MEXICO
- NEW ZELAND
- RUSSIA
- SOUTH AFRICA
- TAIWAN
- UNITED STATES
- AUSTRIA
- BELGIUM
- BULGARIA
- FINLAND
- FRANCE
- GERMANY
- GREECE
- ENGLAND
- HOLLAND
- POLAND
- CZECH REPUBLIC
- REPUBLIC OF SLOVAKIA
- SPAIN
- SWEDEN
- TURKEY
- HUNGARY

