

ARUSH SWITCHGEARS

1801, 2nd Floor Bhagirath Palace, Delhi
9312211087/9811514724
enquiry@arushswitchgears.com
www.arushswitchgears.com

Numerous Brands
One Supplier

ARUSH



At *Arush Switchgears*, it is our always our constant endeavour to help our esteemed customers get the best on most competitive market prices.

Our strong alliance with the broad-list of brands helps us to always offer an extensive range of items, new product introductions from latest technologies as soon as they are available in the market. There are new products that are introduced on regular basis, from over a ocean of brands.

We'd really appreciate if you can share your product requirements for following brands & categories to get the best quotes from us.

Our Range

Automation & Control Gears	Lighting
Batteries	Pneumatics
Cables & Wires	Power Supplies
Connectors	Relays
Displays & Optoelectronics	ESD Control & Clean Room
Electricals	Sockets & Circuit Breakers
Enclosure & Storage	Switches
Fuses	Test & Measurement
HVAC, Fan & Thermal Management	Tools

Our Top Brands



PHOTOELECTRIC

FEATURED	page 34
RECTANGLE	page 74
RIGHT ANGLE	page 105
BARREL	page 130
SLOT & AREA	page 142
MINIATURE	page 152
FIBER OPTICS	page 162



Featured

The featured sensors are the most versatile sensors available in the photoelectric line. Featured sensors have a variety of mounting styles and options, housing options, configuration modes, ranges, response speeds and many more. Start here to find solutions that meet your sensing needs.

Series	Description	Max Sensing Range	Dimensions (H x W x D)	Protection Rating	Housing Material	Power Supply
	<p>Q4X The Q4X is a versatile, rugged, laser distance sensor that solves the most challenging applications. page 34</p>	<p>Laser Adjustable-Field: 25-610 mm</p>	<p>Q4XT 57.4 x 18 x 43.6 mm</p> <p>Q4XF 57.4 x 18 x 32.5 mm</p>	<p>IP67 IP68 IP69K</p>	<p>Stainless Steel</p>	<p>10 to 30 V dc</p>
	<p>Q3X The Q3X is a versatile, rugged, laser contrast sensor that solves challenging applications. page 38</p>	<p>Laser Diffuse: 300 mm Fixed-Field: 200 mm</p>	<p>48.6 x 18 x 24.3 mm</p>	<p>IP67 IP68 IP69K</p>	<p>Nickel-plated Zinc</p>	<p>10 to 30 V dc</p>
	<p>QS18 General purpose sensor to solve most applications page 40</p>	<p>Opposed: 20 m Laser Emitter: 15 m Retro: 6.5 m Polarized Retro: 3.5 m Laser Retro Polarized: 10 m Convergent: 43 mm Diffuse: 1 m Laser Diffuse: 300 mm Fixed-Field: 100 mm Adjustable-Field: 300 mm Laser Adjustable-Field: 250 mm</p>	<p>Varies by model</p>	<p>IP67 NEMA 6</p>	<p>ABS</p>	<p>10 to 30 V dc 20 to 140 V ac/dc 20 to 270 V ac/dc</p>
	<p>QS30 Performance sensor page 56</p>	<p>Opposed: 213 m Opposed Water Dect: 8 m Retro: 12 m Retro Clear Object: 2 m Polarized Retro: 8 m Laser Polarized Retro: 18 m Diffuse: 1.4 m Laser Diffuse: 800 mm Fixed-Field: 600 mm Adjustable-Field: 600 mm</p>	<p>Varies by model</p>	<p>IP67 NEMA 6P</p>	<p>ABS</p>	<p>10 to 30 V dc 24 to 250 V ac 12 to 250 V dc</p>
	<p>Q12 Self-contained miniature sensor page 66</p>	<p>Opposed: 2 m Retro: 1.5 m Polarized Retro: 1 m Fixed-Field: 50 mm</p>	<p>22 x 8 x 12.4 mm</p>	<p>IP67</p>	<p>Thermoplastic Elastomer</p>	<p>10 to 30 V dc</p>
	<p>Q20 Universal housing page 70</p>	<p>Opposed: 20 m Retro: 6 m Polarized Retro: 4 m Diffuse: 1.5 m Fixed-Field: 150 mm</p>	<p>32 x 12 x 29 mm</p>	<p>IP67 NEMA 6</p>	<p>ABS</p>	<p>10 to 30 V dc</p>

Q4X Series

Versatile, Rugged, Laser Measurement Sensor



- Save time and money with the Q4X which is **ready to measure right out of the box**
- A simple user experience from installation to setup
 - Bright spot alignment
 - Three push buttons simplify setup
 - Intuitive menus
- Four-digit display **shows distance to target in mm**
- **FDA-grade stainless steel** is suitable for IP69K washdown environments

Error-Proofing

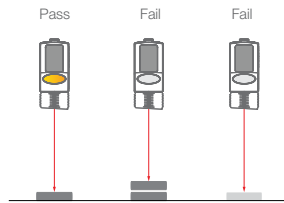

Distance	✓	✗	✓
Color	✓	✓	✗

Measurement

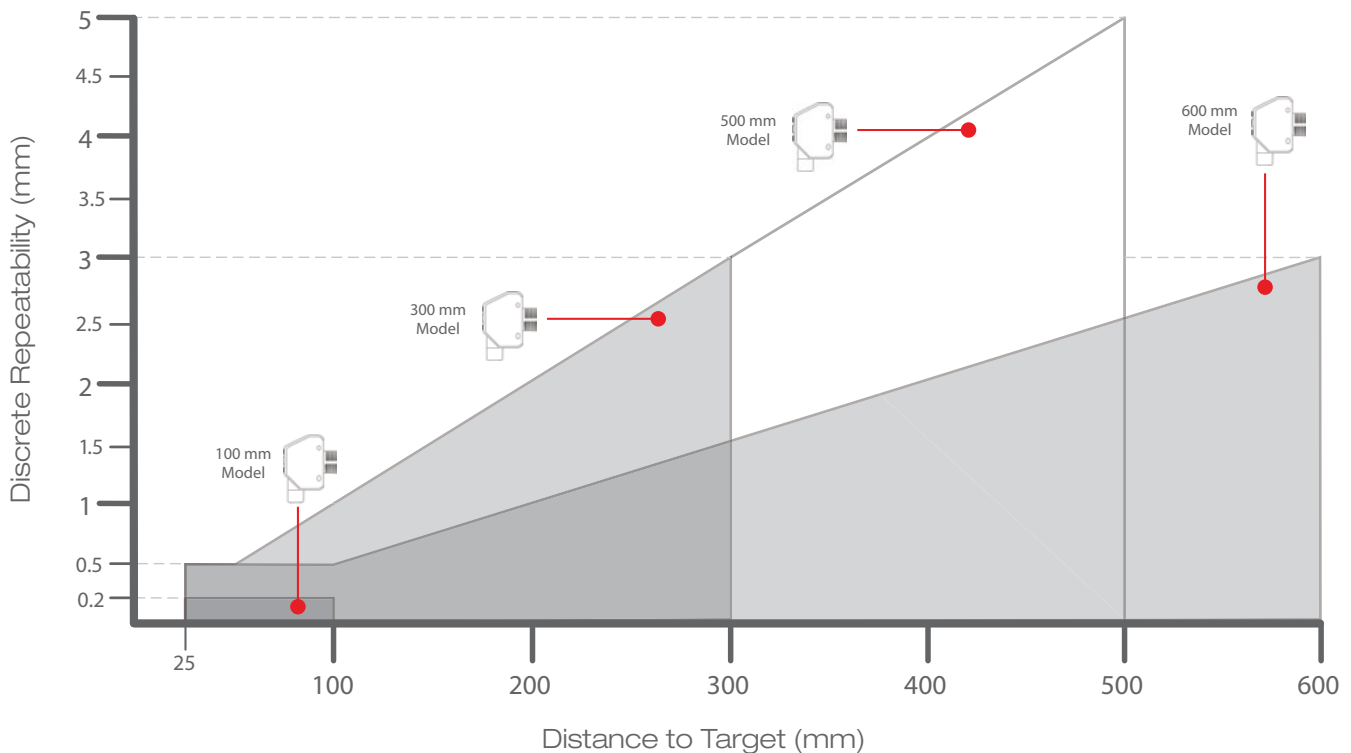
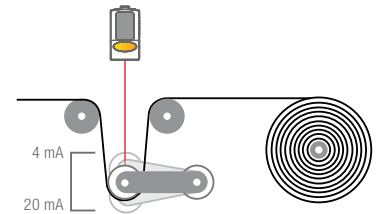

Cordsets for Analog Models

0 to 10 V, 4 to 20 mA

M12/Euro-Style with Shield

Straight connector models listed; for right-angle, add RA to the end of the model number (example, MQDEC2-506RA)



5-Pin
MQDEC2-506
 2 m (6.5')
MQDEC2-515
 5 m (15')
MQDEC2-530
 9 m (30')

M12/Euro-Style Washdown (IP68) with Shield

Straight connector models only



5-Pin
MQDCWD-506
 2 m (6.5')
MQDCWD-530
 9 m (30')

Additional cordset information is available
 See page 758

Cordsets for Other Models

Dual Discrete (4-pin) and Bipolar NPN & PNP (5-pin)

M12/Euro-Style

Straight connector models listed; for right-angle, add RA to the end of the model number (example, MQDC1-506RA)



4-Pin	5-Pin
MQDC-406	MQDC1-506
2 m (6.5')	2 m (6.5')
MQDC-415	MQDC1-515
5 m (15')	5 m (15')
MQDC-430	MQDC1-530
9 m (30')	9 m (30')

M12/Euro-Style Washdown (IP69K)

Straight connector models only



4-Pin	5-Pin
MQDC-WDSS-0406	MQDC-WDSS-0506
2 m (6.5')	2 m (6.5')
MQDC-WDSS-0415	MQDC-WDSS-0515
5 m (15')	5 m (15')
MQDC-WDSS-0430	MQDC-WDSS-0530
9 m (30')	9 m (30')

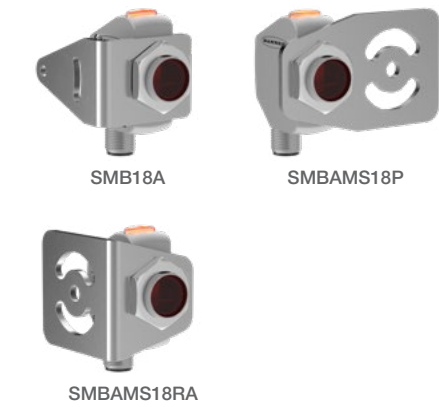

SMB18A

SMBAMS18P

SMBAMS18RA

SMB46L2



SMBQ4XFA
 includes 3/8" bolt for mounting

SMBQ4XFAM10
 includes 10 mm bolt for mounting

SMBQ4XFAM12
 clamps directly onto industry standard bracket systems of 1/2" or 12 mm rods

Additional bracket information is available
 See page 722





Q4XT.. models



Q4XF.. models

Q4X Specifications

Supply Voltage and Current	10 to 30 V dc at less than 675 mW 12 to 30 V dc for Analog models					
Laser Characteristics	Wavelength: Class 1 Laser: 655 nm visible red					
Beam Spot Size	Short Range Models			Long Range Models		
	Distance (mm)		Size (Horizontal x Vertical)	Distance (mm)		Size (Horizontal x Vertical)
	Threaded	Flush		Threaded	Flush	
25	35	2.4 mm x 1.0 mm	25	35	2.6 mm x 1.0 mm	
50	60	2.3 mm x 0.9 mm	150	160	2.3 mm x 0.9 mm	
100	110	1.8 mm x 0.7 mm	300	310	2.0 mm x 0.8 mm	
			600	610	1.9 mm x 1.0 mm	
Output Response Time	User selectable: 50 ms, 25 ms, 10 ms, 3 ms and 1.5 ms					
Excess Gain	HIGH Excess Gain (STANDARD Excess Gain*)					
	Excess Gain (90% white card)					
Response Speed (ms)	Threaded at 25 mm Flush at 35 mm	Threaded at 100 mm Flush at 110 mm	Threaded at 300 mm Flush at 310 mm			
1.5	200	100	20			
3	200	100	20			
10	1000 (500*)	500 (250*)	100 (50*)			
25	2500 (1000*)	1250 (500*)	250 (100*)			
50	5000 (2500*)	2500 (1250*)	500 (250*)			
* Std excess gain provides increased noise immunity (only available in 50 ms, 25 ms, 10 ms)						
Response Speed (ms)	Excess Gain (90% white card)					
	Threaded at 25 mm Flush at 35 mm	Threaded at 100 mm Flush at 110 mm	Threaded at 300 mm Flush at 310 mm	Threaded at 600 mm Flush at 610 mm		
2	280	110	25	6		
5	280	110	25	6		
15	1000 (360)	400 (150)	80 (30)	20 (7)		
25	2000 (1000)	800 (400)	160 (80)	40 (20)		
50	4000 (2000)	1600 (800)	320 (160)	80 (40)		
Resolution & Linearity	See datasheet for more information on analog models					
Construction	Housing 316 L stainless steel; PMMA acrylic lens cover, Polysulfone lightpipe and display window					
Ambient Light Immunity	Greater than 5,000 lux at 300 mm > 2,000 lux at 500 mm					
Environmental Rating	IP67 per IEC60529; IP68 per IEC60529; IP69K per DIN40050-9					
Operating Conditions	Temperature: -10 °C to +50 °C Humidity: 35% to 95% relative humidity					
Certifications	   chemical compatibility on some models; contact Banner Engineering for details					

Q3X Series

Versatile, Rugged, Laser Contrast Sensors



- Solves contrast applications capturing **up to 2,000 events a second**
- Rugged metal, laser-marked housing for use in environments with chemical and oil exposure
- **Three-digit display** offers immediate feedback for easy setup and troubleshooting
- Bright output indicator provides high visibility of sensor operation
- Superior resistance to ambient light interference

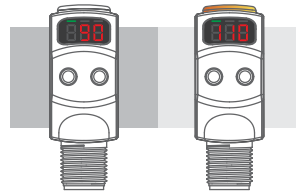

Can detect small changes in contrast up to 300 mm

Q3X

Example Model Number: Q3XTBLD-Q8

Family	Housing Style	Output	Mode & Range	Connector
Q3X	T	B	LD	Q8
	T = 18 mm Threaded Barrel	B = Bipolar (NPN & PNP)	LD = Laser Diffuse, 300 mm LD50 = Laser Diffuse, 50 mm (60 mm background suppression) LD100 = Laser Diffuse, 100 mm (120 mm background suppression) LD150 = Laser Diffuse, 150 mm (190 mm background suppression) LD200 = Laser Diffuse, 200 mm (280 mm background suppression)	Q8 = 5-pin Integral QD

 Connection Option: A model with a QD requires a mating cordset.

M12/Euro-Style
Straight connector models listed; for right-angle, add **RA** to the end of the model number (example, MQDC1-506RA)



5-Pin

- MQDC1-501.5**
0.5 m (1.5')
- MQDC1-506**
2 m (6')
- MQDC1-515**
5 m (15')
- MQDC1-530**
9 m (30')



SMBQ4XFA
includes 3/8" bolt for mounting

SMBQ4XFAM10
includes 10 mm bolt for mounting



SMB18A

M12/ Euro-Style Washdown (IP69K)
Straight connector models only



5-Pin

- MQDC-WDSS-0506**
2 m (6')
- MQDC-WDSS-0515**
5 m (15')
- MQDC-WDSS-0530**
9 m (30')

SMBQ4XFAM12
clamps directly onto industry standard bracket systems of 1/2" or 12 mm rods

*Additional bracket information is available
See page 722*

*Additional cordset information is available
See page 758*

Q3X Specifications

Supply Voltage and Current	10 to 30 V dc														
Laser Characteristics	Wavelength: Class 2 Laser (655 nm visible red)														
Supply Protection Circuitry	Protected against reverse polarity and transient voltages														
Beam Spot Size	For models LD, LD100, LD150, LD200 (LD50 models*) <table border="1" style="margin-left: 20px;"> <thead> <tr> <th>Distance (mm)</th> <th>Size (Horizontal x Vertical)</th> </tr> </thead> <tbody> <tr> <td>20</td> <td>5.9 mm x 2.3 mm (4.8 mm x 2.0 mm*)</td> </tr> <tr> <td>50</td> <td>5.6 mm x 2.1 mm (3.4 mm x 1.4 mm*)</td> </tr> <tr> <td>100</td> <td>5.1 mm x 1.9 mm</td> </tr> <tr> <td>150</td> <td>4.6 mm x 1.6 mm</td> </tr> <tr> <td>200</td> <td>4.1 mm x 1.6 mm</td> </tr> <tr> <td>300</td> <td>3.0 mm x 1.2 mm</td> </tr> </tbody> </table>	Distance (mm)	Size (Horizontal x Vertical)	20	5.9 mm x 2.3 mm (4.8 mm x 2.0 mm*)	50	5.6 mm x 2.1 mm (3.4 mm x 1.4 mm*)	100	5.1 mm x 1.9 mm	150	4.6 mm x 1.6 mm	200	4.1 mm x 1.6 mm	300	3.0 mm x 1.2 mm
Distance (mm)	Size (Horizontal x Vertical)														
20	5.9 mm x 2.3 mm (4.8 mm x 2.0 mm*)														
50	5.6 mm x 2.1 mm (3.4 mm x 1.4 mm*)														
100	5.1 mm x 1.9 mm														
150	4.6 mm x 1.6 mm														
200	4.1 mm x 1.6 mm														
300	3.0 mm x 1.2 mm														
Output Configuration	Bipolar (1 PNP & 1 NPN) output Off-state leakage current: less than 10 µA PNP On-state saturation voltage: less than 200 mV at 10 mA load and less than 1.0 V at 100 mA NPN On-state saturation voltage: less than 1.0 V at 10 mA load and less than 2.0 V at 100 mA														
Output Response Time	User selectable: 250 µs, 1 ms and 5 ms														
Delay at Power-up	1 second														
Ambient Light Immunity	Greater than 5000 lux														
Repeatability	60 µs														
Construction	Housing nickel-plated zinc die-cast; PMMA acrylic lens cover														
Environmental Rating	IP67 per IEC60529; IP68 per IEC60529; IP69K per DIN40050-9														
Connections	5-pin Euro M12 Integral Connector														
Performance Curves	See datasheet														
Operating Conditions	Temperature: -10 °C to +55 °C Humidity: 35% to 95% relative humidity														



Certifications

QS18 Series

Versatile Sensor for Global Manufacturing Needs



- All-purpose sensors solve the widest variety of sensing applications
- Versatile sensor with many mounting options
- Meets IP67 and NEMA 6 standards for use in harsh environments
- Universal housing for global use
- Cordsets and brackets see page 51



QS18

page 42

The QS18 Standard Sensor requires little to no adjustment. The sensor is available in multiple sensing modes and has a wide variety of connection options.



QS18 Expert™

page 44

The QS18 Expert™ offers advanced sensing with single push-button programming and several sensing modes and configuration options.



QS18 Clear Object

page 45

The QS18 Clear Object sensor is designed for clear object detection in plastic or glass containers.

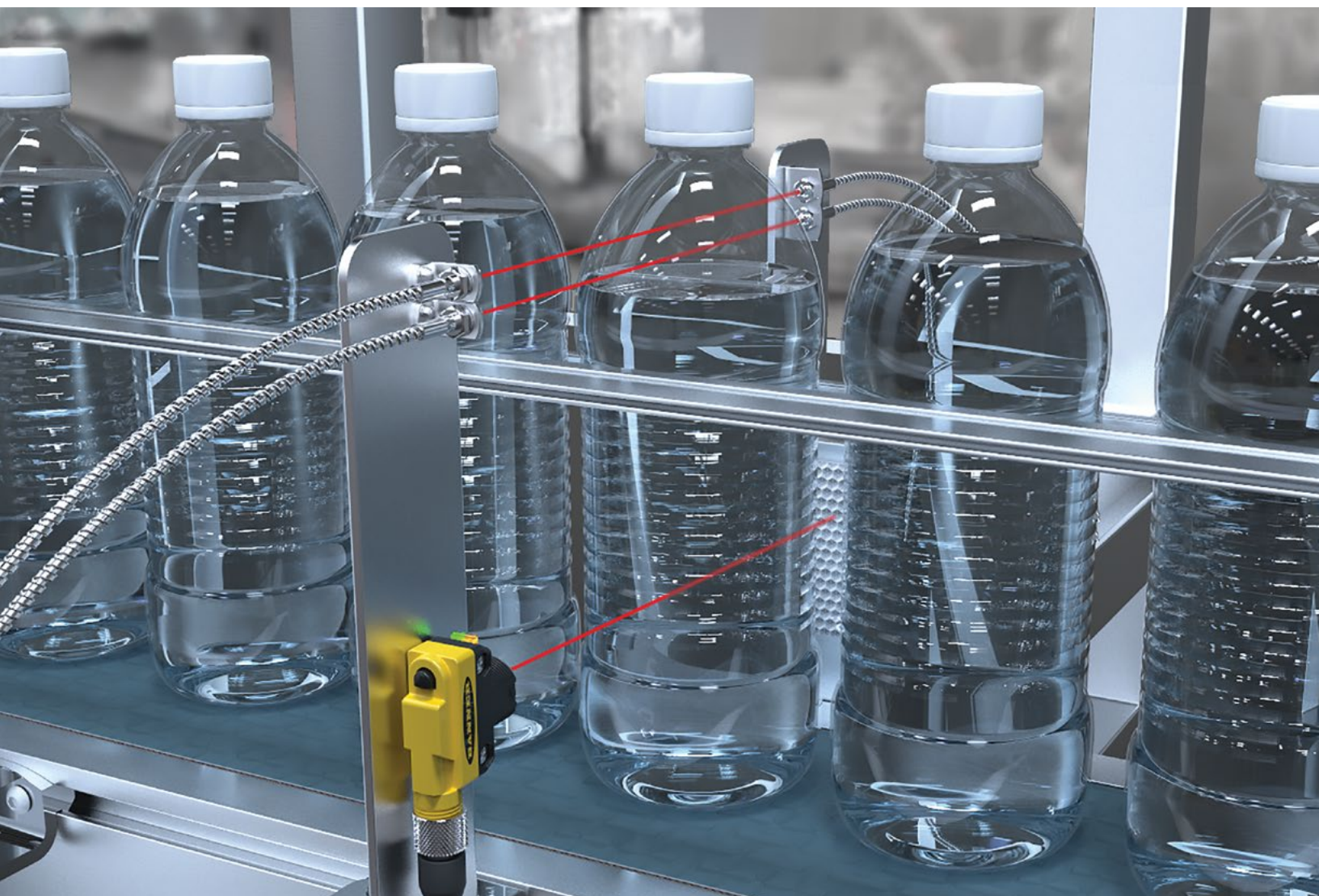

QS18 Laser **page 46**

The QS18 Laser Sensor has a narrow visible beam spot for easy alignment and small object detection.



QS18 Adjustable-Field **page 48**

The QS18 Adjustable-Field Sensor is ideal for background and foreground suppression. The sensor is available in long-range models for sensing up to 300 mm.



QS18 Universal Voltage **page 50**

The QS18 Universal Voltage Sensor operates on ac or dc voltage and has several sensing modes available, making it an ideal sensor for many manufacturing environments.

QS18

DC-Operated Sensors



- All-purpose sensor solves widest variety of sensing applications
- Simple set-up with 270 degree potentiometer and fixed sensitivity models
- Versatile sensor with many mounting options
- Meets IP67 and NEMA 6 standards for use in wet environments
- Universal housing for global use
- Cordsets and brackets see page 51

Opposed QS18

⇨ Infrared LED → Visible Red LED

Sensing Mode	Range	Connection	Models NPN*	Models PNP*
 OPPOSED	20 m	2 m	QS186E Emitter	
		4-pin Euro QD	QS186EQ8 Emitter	
 OPPOSED	20 m	2 m	QS18VN6R	QS18VP6R
		4-pin Euro QD	QS18VN6RQ8	QS18VP6RQ8
 OPPOSED	3 m	2 m	QS186EB Emitter	
		4-pin Euro QD	QS186EBQ8 Emitter	
 OPPOSED	3 m	2 m	QS18VN6RB	QS18VP6RB
		4-pin Euro QD	QS18VN6RBQ8	QS18VP6RBQ8



Box Sorting for Size

Three QS18 opposed mode sensors above the roller conveyor detect any passing object, triggering the horizontal QS18 sensor. Boxes are diverted by size as they continue forward.

Retro & Polar Retro QS18

→ Visible Red LED

Sensing Mode	Range	Connection	Models NPN*	Models PNP*
 RETRO	6.5 m [†]	2 m	QS18VN6LV	QS18VP6LV
		4-pin Euro QD	QS18VN6LVQ8	QS18VP6LVQ8
 POLAR RETRO	3.5 m [†]	2 m	QS18VN6LP	QS18VP6LP
		4-pin Euro QD	QS18VN6LPQ8	QS18VP6LPQ8

For more specifications see page 52.

Connection options: A model with a QD requires a mating cordset (see page 51).

For 9 m cable, add suffix W/30 to the 2 m model number (example, QS18VN6LV W/30).

QD models

- For 4-pin integral Pico-style QD, add suffix Q7 (example, QS18VN6LVQ7).
- For 4-pin 150 mm Euro-style pigtail QD, add suffix Q5 (example, QS18VN6LVQ5).
- For 4-pin 150 mm Pico-style pigtail QD, add suffix Q (example, QS18VN6LVQ).

[†] Retroreflective range is specified using one model BRT-84 retroreflector.

* Contact factory at 1-888-373-6767 for Bipolar NPN/PNP output model options.

Actual sensing range may differ, depending on the efficiency and reflective area of the retroreflector used. See Accessories for more information.

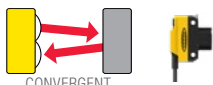

Convergent QS18

➔ Visible Red LED

Sensing Mode	Range	Connection	Models NPN*	Models PNP*
 CONVERGENT	16 mm	2 m	QS18VN6CV15	QS18VP6CV15
		4-pin Euro QD	QS18VN6CV15Q8	QS18VP6CV15Q8
 CONVERGENT	43 mm	2 m	QS18VN6CV45	QS18VP6CV45
		4-pin Euro QD	QS18VN6CV45Q8	QS18VP6CV45Q8

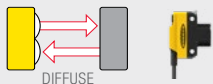
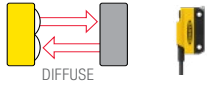
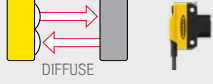

Diffuse QS18

➔ Infrared LED

Sensing Mode	Range	Connection	Models NPN*	Models PNP*
 DIFFUSE	450 mm	2 m	QS18VN6D	QS18VP6D
		4-pin Euro QD	QS18VN6DQ8	QS18VP6DQ8
 DIFFUSE	450 mm	2 m	QS18VN6DB	QS18VP6DB
		4-pin Euro QD	QS18VN6DBQ8	QS18VP6DBQ8
 DIFFUSE	600 mm	2 m	QS18VN6DL	QS18VP6DL
		4-pin Euro QD	QS18VN6DLQ8	QS18VP6DLQ8
 DIVERGENT DIFFUSE	100 mm	2 m	QS18VN6W	QS18VP6W
		4-pin Euro QD	QS18VN6WQ8	QS18VP6WQ8

Fixed-Field QS18

➔ Visible Red LED

Sensing Mode	Range	Connection	Models NPN*	Models PNP*
 FIXED-FIELD	0-50 mm Cutoff	2 m	QS18VN6FF50	QS18VP6FF50
		4-pin Euro QD	QS18VN6FF50Q8	QS18VP6FF50Q8
 FIXED-FIELD	0-100 mm Cutoff	2 m	QS18VN6FF100	QS18VP6FF100
		4-pin Euro QD	QS18VN6FF100Q8	QS18VP6FF100Q8

Coaxial QS18 Clear Object Detection

➔ Visible Red LED

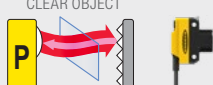
Sensing Mode	Range**	Connection	Models NPN*	Models PNP*
 CLEAR OBJECT RETRO	0-3 m	2 m	QS18VN6XLP	QS18VP6XLP
		4-pin Euro QD	QS18VN6XLPQ8	QS18VP6XLPQ8

For more specifications see page 52.

➔ Connection options: A model with a QD requires a mating cordset (see page 51).

For 9 m cable, add suffix W/30 to the 2 m model number (example, QS18VN6LV W/30).

QD models

- For 4-pin integral Pico-style QD, add suffix Q7 (example, QS18VN6LVQ7).
- For 4-pin 150 mm Euro-style pigtail QD, add suffix Q5 (example, QS18VN6LVQ5).
- For 4-pin 150 mm Pico-style pigtail QD, add suffix Q (example, QS18VN6LVQ).

* Contact factory at 1-888-373-6767 for Bipolar NPN/PNP output model options.

** For use with BRT-92X92C

Actual sensing range may differ, depending on the efficiency and reflective area of the retroreflector used. See Accessories for more information.

QS18 Expert™

Sensors with Push-Button Programming



- Intuitive push-button lock out to prevent accidental configuration changes
- Bright LED status indicators visible from 360°
- Reliable detection of reflective objects
- Cordsets and brackets see page 51

Polar Retro QS18 Expert™

➔ Visible Red LED

Sensing Mode	Range	Connection	Models NPN*	Models PNP*
<p>POLAR RETRO</p>	3.5 m†	2 m	QS18EN6LP	QS18EP6LP
		4-pin Euro QD	QS18EN6LPQ8	QS18EP6LPQ8

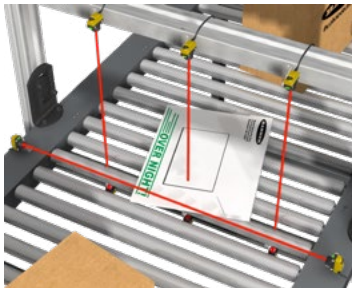

Mail Sorting for Size

Three QS18 opposed mode sensors above the roller conveyor detect any passing object, triggering the horizontal QS18 sensor. Letters pass below the horizontal QS18 undetected and are diverted to the letter conveyor. Parcels are detected and continue forward.

Convergent QS18 Expert™

➔ Visible Red LED

Sensing Mode	Range	Connection	Models NPN*	Models PNP*
<p>CONVERGENT</p>	16 mm	2 m	QS18EN6CV15	QS18EP6CV15
		4-pin Euro QD	QS18EN6CV15Q8	QS18EP6CV15Q8
<p>CONVERGENT</p>	43 mm	2 m	QS18EN6CV45	QS18EP6CV45
		4-pin Euro QD	QS18EN6CV45Q8	QS18EP6CV45Q8

For more specifications see page 53.

➔ Connection options: A model with a QD requires a mating cordset (see page 51).

For 9 m cable, add suffix W/30 to the 2 m model number (example, QS18EN6LP W/30).

QD models

- For 4-pin integral Pico-style QD, add suffix Q7 (example, QS18EN6LPQ7).
- For 4-pin 150 mm Euro-style pigtail QD, add suffix Q5 (example, QS18EN6LPQ5).
- For 4-pin 150 mm Pico-style pigtail QD, add suffix Q (example, QS18EN6LPQ).

† Retroreflective range is specified using one model BRT-84 retroreflector.

Actual sensing range may differ, depending on the efficiency and reflective area of the retroreflector used. See Accessories for more information.

* Contact factory at 1-888-373-6767 for Bipolar NPN/PNP output model options.

Diffuse QS18 Expert™

 Infrared LED  Visible Red LED

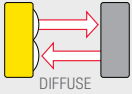
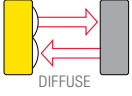
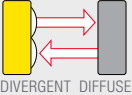
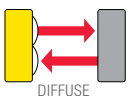
Sensing Mode	Range	Connection	Models NPN*	Models PNP*
 DIFFUSE	800 mm	2 m	QS18EN6D	QS18EP6D
		4-pin Euro QD	QS18EN6DQ8	QS18EP6DQ8
 DIFFUSE	500 mm	2 m	QS18EN6DB	QS18EP6DB
		4-pin Euro QD	QS18EN6DBQ8	QS18EP6DBQ8
 DIVERGENT DIFFUSE	300 mm	2 m	QS18EN6W	QS18EP6W
		4-pin Euro QD	QS18EN6WQ8	QS18EP6WQ8
 DIFFUSE	600 mm	2 m	QS18EN6DV	QS18EP6DV
		4-pin Euro QD	QS18EN6DVQ8	QS18EP6DVQ8

Coaxial QS18 Expert™ Clear Object Detection

 Visible Red LED

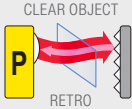
Sensing Mode	Range	Connection	Models NPN*	Models PNP*
 CLEAR OBJECT RETRO	0-3 m	2 m	QS18EN6XLPC	QS18EP6XLPC
		4-pin Euro QD	QS18EN6XLPCQ8	QS18EP6XLPCQ8

Coaxial QS18 Expert™ Clear Object Detection with IO-Link

 Visible Red LED

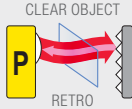
Sensing Mode	Range	Connection	Models
 CLEAR OBJECT RETRO	0-3 m	2 m	QS18EK6XLPC
		4-pin Euro QD	QS18EK6XLPCQ8

Plastic Fiber QS18 Expert™

 Visible Red LED

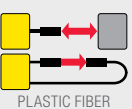
Sensing Mode	Range	Connection	Models NPN*	Models PNP*
 PLASTIC FIBER	Range varies by sensing mode and fiber optics used	2 m	QS18EN6FP	QS18EP6FP
		4-pin Euro QD	QS18EN6FPQ8	QS18EP6FPQ8

For more specifications see page 53.

 Connection options: A model with a QD requires a mating cordset (see page 51).

For 9 m cable, add suffix W/30 to the 2 m model number (example, QS18EN6D W/30).

QD models

- For 4-pin integral Pico-style QD, add suffix Q7 (example, QS18EN6DQ7).
- For 4-pin 150 mm Euro-style pigtail QD, add suffix Q5 (example, QS18EN6DQ5).
- For 4-pin 150 mm Pico-style pigtail QD, add suffix Q (example, QS18EN6DQ).

* Actual sensing range may differ, depending on the efficiency and reflective area of the retroreflector used. See Accessories for more information.

* Contact factory at 1-888-373-6767 for Bipolar NPN/PNP output model options.

** For use with BRT-92X92C

QS18 Laser

DC-Operated Long-Range Laser Sensors



- The QS18 Laser Emitter has a narrow visible beam spot for easy alignment and small object detection.
- Long sensing ranges
- Available in opposed, diffuse and retroreflective mode (see page 48 for adjustable-field models)
- Cordsets and brackets see page 51

Class 1 Laser QS18

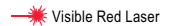

Sensing Mode	Range	Connection	Models NPN*	Models PNP*
	15 m (4500 x excess gain)	2 m 4-pin Euro QD	QS186LE Emitter**	QS186LEQ8 Emitter**
	See datasheet for more information.	2 m 4-pin Euro QD	QS186LE10	QS186LE10Q8
	See datasheet for more information.	2 m 4-pin Euro QD	QS186LE11	QS186LE11Q8
	See datasheet for more information.	2 m 4-pin Euro QD	QS186LE12	QS186LE12Q8
	See datasheet for more information.	2 m 4-pin Euro QD	QS186LE14	QS186LE14Q8
	0.1-10 m†	2 m 4-pin Euro QD	QS18VN6LLP	QS18VP6LLP
	300 mm	2 m 4-pin Euro QD	QS18VN6LD	QS18VP6LD
			QS18VN6LLPQ8	QS18VP6LLPQ8
			QS18VN6LDQ8	QS18VP6LDQ8



Package Inspection Using Diffuse-Mode Laser Sensors

When packaging medical supplies, error-proofing and quality control are of the utmost importance. In this application, it's necessary to inspect each package of gauze pads to ensure that the lid has been closed and that tape has been applied to seal the package. Automating this process means greater efficiency and less chance of error.

For more specifications see page 52.

Connection options: A model with a QD requires a mating cordset (see page 51).

For 9 m cable, add suffix **W/30** to the 2 m model number (example, **QS186LE W/30**).

QD models

- For 4-pin integral Euro-style QD, add suffix **Q7** (example, **QS186LEQ7**).
- For 4-pin 150 mm Euro-style pigtail QD, add suffix **Q5** (example, **QS186LEQ5**).
- For 4-pin 150 mm Pico-style pigtail QD, add suffix **Q** (example, **QS186LEQ**).

† Retroreflective range is specified using one model BRT-51X51BM or BRT-TVHG-2X2 retroreflector.
Actual sensing range may differ, depending on the efficiency and reflective area of the retroreflector used. See Accessories for more information.

* Contact factory at 1-888-373-6767 for Bipolar NPN/PNP output model options.

** Specified with QS18 threaded lens receiver. Not recommended for dusty or dirty environments; the scattered light would greatly reduce excess gain.
For use with standard QS18 opposed mode receivers

Class 2 Laser QS18

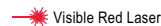

Sensing Mode	Range	Connection	Models*
	15 m (7000 X excess gain)	2 m 4-pin Euro QD	QS186LE2 Emitter** QS186LE2Q8 Emitter**
	See datasheet for more information	2 m 4-pin Euro QD	QS186LE210 QS186LE210Q8
	See datasheet for more information	2 m 4-pin Euro QD	QS186LE211 QS186LE211Q8
	See datasheet for more information	2 m 4-pin Euro QD	QS186LE212 QS186LE212Q8
	See datasheet for more information	2 m 4-pin Euro QD	QS186LE214 QS186LE214Q8

Class 1 Laser Sensors

Lasers that are safe under reasonably foreseeable conditions of operation, including the use of optical instruments for intrabeam viewing. Reference IEC 60825-1: 2001, section 8.2.

Class 2 Lasers

Lasers that emit visible radiation in the wavelength range from 400 nm to 700 nm, where eye protection is normally afforded by aversion responses, including the blink reflex. This reaction may be expected to provide adequate protection under reasonably foreseeable conditions of operation, including the use of optical instruments for intrabeam viewing. Reference IEC 60825-1:2001, section 8.2.

For safe laser use (Class 1 or Class 2):

- Do not permit a person to stare at the laser from within the beam.
- Do not point the laser at a person's eye at close range.
- Terminate the beam emitted by a Class 2 laser product at the end of its useful path.
- Locate open laser beam paths either above or below eye level, where practical.

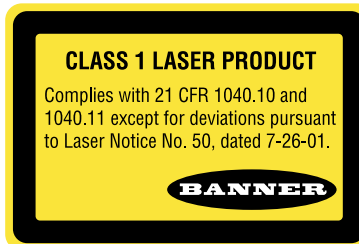

For more specifications see page 52.

Connection options: A model with a QD requires a mating cordset (see page 51).

For 9 m cable, add suffix W/30 to the 2 m model number (example, QS186LE2 W/30).

QD models

- For 4-pin 150 mm Pico-style pigtail QD, add suffix Q (example, QS186LE2Q).

* Contact factory at 1-888-373-6767 for Bipolar NPN/PNP output model options.

** Specified with QS18 threaded lens receiver. Not recommended for dusty or dirty environments; the scattered light would greatly reduce excess gain.

QS18 Adjustable-Field

Foreground and Background Suppression Sensors



- The QS18 Adjustable-Field Sensor is ideal for background and foreground suppression
- The sensor is available in long-range models for sensing up to 300 mm
- Background suppression models for detection of objects when the background condition is not fixed
- Foreground suppression models for detection when background is fixed and object varies in color or shape
- Visible red LED or laser sensing beam
- Cordsets and brackets see page 51

Adjustable-Field Foreground Suppression

Foreground suppression models for reliable detection when a fixed background is present and the object color or shape varies

- Objects detected to the face of the sensor (no dead zone).
- Simple multiturn screw adjustment of cutoff distance
- Enhanced immunity to fluorescent lights
- Crosstalk immunity algorithm allows two sensors to be used in close proximity
- Visible red emitter

Adjustable-Field Foreground QS18



Sensing Mode	Range	Connection	Models NPN*	Models PNP*
<p>ADJUSTABLE-FIELD FOREGROUND</p>	Adjustable between 30-200 mm	2 m	QS18AB6AFF200 (Bipolar NPN/PNP)	
		4-pin Euro Pigtail QD	QS18AB6AFF200Q5 (Bipolar NPN/PNP)	
		2 m	QS18VN6AFF200	QS18VP6AFF200
		4-pin Euro Pigtail QD	QS18VN6AFF200Q5	QS18VP6AFF200Q5
<p>ADJUSTABLE-FIELD FOREGROUND</p>	Adjustable between 15-40 mm	2 m	QS18AB6AFF40 (Bipolar NPN/PNP)	
		4-pin Euro Pigtail QD	QS18AB6AFF40Q5 (Bipolar NPN/PNP)	
		2 m	QS18VN6AFF40	QS18VP6AFF40
		4-pin Euro Pigtail QD	QS18VN6AFF40Q5	QS18VP6AFF40Q5

For more specifications see page 52.

Connection options: A model with a QD requires a mating cordset (see page 51).

For 9 m cable, add suffix W/30 to the 2 m model number (example, QS18VN6AFF200 W/30).

QD models

- For 4-pin 150 mm Pico-style pigtail QD, add suffix Q (example, QS18EN6LPQ).
- * Contact factory at 1-888-373-6767 for Bipolar NPN/PNP output model options.

Adjustable-Field Background Suppression QS18



Sensing Mode	Range	Connection	Models NPN*	Models PNP*
<p>ADJUSTABLE-FIELD BACKGROUND SUPPRESSION</p>	Adjustable between 30-300 mm	2 m	QS18AB6AF300 (Bipolar NPN/PNP)	
		4-pin Euro Pigtail QD	QS18AB6AF300Q5 (Bipolar NPN/PNP)	
		2 m	QS18VN6AF300	QS18VP6AF300
		4-pin Euro Pigtail QD	QS18VN6AF300Q5	QS18VP6AF300Q5
<p>ADJUSTABLE-FIELD BACKGROUND SUPPRESSION</p>	Adjustable between 15-40 mm	2 m	QS18AB6AF40 (Bipolar NPN/PNP)	
		4-pin Euro Pigtail QD	QS18AB6AF40Q5 (Bipolar NPN/PNP)	
		2 m	QS18VN6AF40	QS18VP6AF40
		4-pin Euro Pigtail QD	QS18VN6AF40Q5	QS18VP6AF40Q5
<p>ADJUSTABLE-FIELD BACKGROUND SUPPRESSION</p>	1 mm to cutoff point (adjustable between 20-100 mm)	2 m	QS18VN6AF100	QS18VP6AF100
		4-pin Euro Pigtail QD	QS18VN6AF100Q5	QS18VP6AF100Q5
<p>LASER (CLASS 1) ADJUSTABLE-FIELD BACKGROUND SUPPRESSION</p>	1 mm to cutoff point (adjustable between 30-150 mm)	2 m	QS18VN6LAF	QS18VP6LAF
		4-pin Euro Pigtail QD	QS18VN6LAFQ5	QS18VP6LAFQ5
<p>LASER (CLASS 2) ADJUSTABLE-FIELD BACKGROUND SUPPRESSION</p>	20 mm to cutoff point (adjustable between 50-250 mm)	2 m	QS18VN6LAF250	QS18VP6LAF250
		4-pin Euro Pigtail QD	QS18VN6LAF250Q5	QS18VP6LAF250Q5

Adjustable-Field Background Suppression

Background suppression models for reliable detection of objects when the background condition is not controlled or fixed

- Simple multiturn screw adjustment of cutoff distance
- Enhanced immunity to fluorescent lights
- Crosstalk immunity algorithm allows two sensors to be used in close proximity
- Visible red emitter

Class 1 Laser Sensors

Lasers that are safe under reasonably foreseeable conditions of operation, including the use of optical instruments for intrabeam viewing. Reference IEC 60825-1: 2001, section 8.2.

Class 2 Lasers

Lasers that emit visible radiation in the wavelength range from 400 nm to 700 nm, where eye protection is normally afforded by aversion responses, including the blink reflex. This reaction may be expected to provide adequate protection under reasonably foreseeable conditions of operation, including the use of optical instruments for intrabeam viewing. Reference IEC 60825-1:2001, section 8.2.

For safe laser use (Class 1 or Class 2):

- Do not permit a person to stare at the laser from within the beam.
- Do not point the laser at a person's eye at close range.
- Terminate the beam emitted by a Class 2 laser product at the end of its useful path.
- Locate open laser beam paths either above or below eye level, where practical.

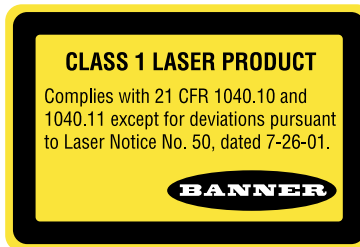

For more specifications see page 52.

Connection options: A model with a QD requires a mating cordset (see page 51).

For 9 m cable, add suffix W/30 to the 2 m model number (example, QS18EN6LP W/30).

QD models

- For 4-pin 150 mm Euro-style pigtail QD, add suffix Q5 (example, QS18EN6LPQ5).
- For 4-pin 150 mm Pico-style pigtail QD, add suffix Q (example, QS18EN6LPQ).

* Contact factory at 1-888-373-6767 for Bipolar NPN/PNP output model options.

QS18 Universal Voltage

Versatile Sensors Operate on AC or DC Voltage



- The QS18 Universal Voltage Sensor operates on ac or dc voltage
- Versatile sensor with many mounting options
- Ready to hook up out of the box
- Cordsets and brackets see page 51

Opposed QS18 Universal Voltage, 20-140 V AC/DC or 20-270 V AC/DC ⇔ Infrared LED

Sensing Mode	Range	Output ^{††}	Models Light Operate	Models Dark Operate
 OPPOSED	20 m	— N-MOSFET (Sinking) P-MOSFET (Sourcing)	QS18WE Emitter	
			QS18ANWR QS18APWR	QS18RNWR QS18RPWR

Polar Retro & Retro QS18 Universal Voltage, 20-140 V AC/DC or 20-270 V AC/DC → Visible Red LED

Sensing Mode	Range	Output ^{††}	Models Light Operate	Models Dark Operate
 POLAR RETRO	3.5 m [†]	N-MOSFET (Sinking) P-MOSFET (Sourcing)	QS18ANWLP QS18APWLP	QS18RNWLP QS18RPWLP
 RETRO	6.5 m [†]	N-MOSFET (Sinking) P-MOSFET (Sourcing)	QS18ANWLV QS18APWLV	QS18RNWLV QS18RPWLV

Diffuse QS18 Universal Voltage, 20-140 V AC/DC or 20-270 V AC/DC → Visible Red LED ⇔ Infrared LED

Sensing Mode	Range	Output ^{††}	Models Light Operate	Models Dark Operate
 DIFFUSE	450 mm	N-MOSFET (Sinking) P-MOSFET (Sourcing)	QS18ANWDL QS18APWDL	QS18RNWDL QS18RPWDL
 DIFFUSE	1 m	N-MOSFET (Sinking) P-MOSFET (Sourcing)	QS18ANWDXL QS18APWDXL	QS18RNWDXL QS18RPWDXL



Conveyor Jam Detection Using Opposed-Mode Sensors

When an object is lodged in front of the sensor an output is triggered, alerting personnel to the presence of the jam. QS18 Universal Voltage sensors can be connected to either ac or dc power, allowing them to operate in applications already using ac power without requiring a separate power supply.

For more specifications see page 53.

Connection options: A model with a QD requires a mating cordset.

For 9 m cable, add suffix W/30 to the 2 m model number (example, QS18WE W/30).

QD models

- For 4-pin 150 mm Micro-style pigtail QD, add suffix Q2 to the model number (example, QS18WEQ2).
- 600 V cable models: Standard models are supplied with 300 V cable. For a 600 V cable, add suffix C1 to the 2 m model number (example, QS18WEC1).

[†] Retroreflective range is specified using one model BRT-B4 retroreflector.
Actual sensing range may differ, depending on the efficiency and reflective area of the retroreflector used. See Accessories for more information.

^{††}MOSFET: Metal oxide semiconductor field-effect transistor.

Euro QD
(for ..Q8 or ..Q5 models)
Straight connector models listed; for right-angle, add **RA** to the end of the model number (example, **MQDC-406RA**)

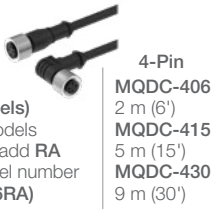

Pico QD
(for Q7 models)
Straight snap-on connector

Pico QD (for Q7 models)
Right-angle snap-on connector



Micro QD
(for ..Q2 models)
Straight connector models listed

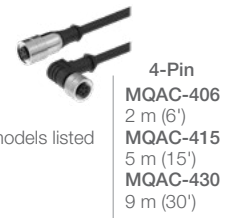

Euro QD with Shield
(for ..Q8 or ..Q5 models)
Straight connector models listed; for right-angle, add **RA** to the end of the model number (example, **MQDEC2-406RA**)

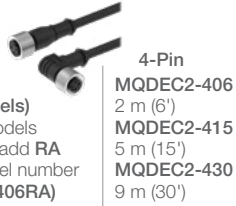

Pico QD with Shield
(for Q7 models)
Straight snap-on connector

Pico QD (for Q7 models)
Right-angle snap-on connector

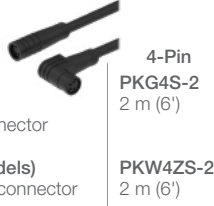

Additional cordset information is available
See page 758



SMBQ4XFA



SMBQS18A



SMB18A



SMBQ18AF

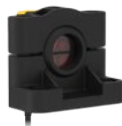

SMB18SF

Additional bracket information is available
See page 722

Reflectors



Additional information is available
See page 790

Apertures



Additional information is available
See page 816



Opposed, Retroreflective, Laser Retroreflective, Convergent, Diffuse, Laser Diffuse and Fixed-Field Models
Suffix E, R, LV, LP, LLP, CV15, CV45, D, DV, LD, LE and FF



Opposed, Diffuse and Divergent Diffuse Models
Suffix EB, RB, DB and W



Adjustable-Field Models
Suffix AFF, AF and LAF



Opposed, Retroreflective, Polar Retroreflective and Diffuse Models
Suffix E, R, LP, LV, DL and XL





Plastic Fiber Models
Suffix FP



Glass Fiber Models
Suffix F

QS18, DC, Laser, Adjustable-Field Specifications

Supply Voltage and Current	Retroreflective, Diffuse and Adjustable-Field Laser: 10 to 30 V dc (10% max. ripple) at less than 15 mA, exclusive of load Laser Emitters: 10 to 30 V dc (10% max. ripple) at less than 35 mA Adjustable-Field (40, 200 & 300 mm): 10 to 30 V dc (10% max. ripple) at less than 27 mA All Others: 10 to 30 V dc (10% max. ripple) at less than 25 mA, exclusive of load			
Laser Characteristics (Laser models only)	Wavelength: Class 1: 650 nm visible red Class 2: Adjustable-Field—658 nm visible red Laser Emitter—650 nm visible red			
Supply Protection Circuitry	Protected against reverse polarity and transient voltages			
Laser Control (Emitters only)	Apply 0 V dc to white wire to enable beam Apply +10 to 30 V dc to white wire to inhibit beam Enable Time: Class 1—240 ms Class 2—8 ms Disable time: Class 1—100 ms Class 2—1 ms			
Output Configuration*	Solid-state complementary: NPN (current sinking), PNP (current sourcing), or bipolar (both sinking and sourcing) depending on model Rating: 100 mA total output current OFF-state leakage current: Adjustable-Field LED (40, 200 & 300 mm), Retroreflective, Diffuse and Adjustable-Field Laser: NPN: less than 200 µA @ 30 V dc (see Application Note 1) PNP: less than 10 µA @ 30 V dc Fixed-Field: less than 200 µA @ 30 V dc All others: less than 50 µA @ 30 V dc ON-state saturation voltage: Adjustable-Field LED (40, 200 & 300 mm), Retroreflective, Diffuse and Adjustable-Field Laser: NPN: less than 1.6 V @ 100 mA PNP: less than 3.0 V @ 100 mA All others: less than 1 V @ 10 mA; less than 1.5 V @ 100 mA Protected against false pulse on power-up and continuous overload or short circuit of outputs			
Output Response Time*	Opposed: 750 microseconds ON; 375 microseconds OFF Retroreflective Laser, Diffuse Laser and Adjustable-Field (100, 150 & 250 mm): 700 microseconds ON/OFF Adjustable-Field (40, 200 & 300 mm): 2.8 milliseconds ON/OFF Fixed-Field: 850 microseconds ON/OFF All others: 600 microseconds ON/OFF			
Delay at Power-up	Laser Emitters: Class 1—250 milliseconds Class 2—10 milliseconds Adjustable-Field LED (40, 200 & 300 mm), Retroreflective, Diffuse and Adjustable-Field Laser: 200 milliseconds; outputs do not conduct during this time. All others: 100 milliseconds; outputs do not conduct during this time.			
Repeatability*	Opposed: 100 microseconds Retroreflective Laser, Diffuse Laser and Adjustable-Field Laser: 130 microseconds Adjustable-Field LED (100 mm): 175 microseconds Adjustable-Field LED (40, 200 & 300 mm): 250 microseconds Fixed-Field: 160 microseconds All Others: 150 microseconds			
Adjustments*	Retro, Retro Laser, Convergent, Diffuse, Diffuse Laser and Glass & Plastic Fiber Optic: Single-turn sensitivity (Gain) adjustment potentiometer Adjustable-Field: Five-turn adjustment screw sets cutoff distance between min. and max. position			
Indicators	Laser Emitters: Green LED: Power applied All others, 2 LED indicators: (Green: Power ON Yellow: Light sensed) See datasheet for detailed information			
Construction	ABS housing; acrylic lens cover (Laser Emitter models have PMMA window) 2.5 mm (adjustable-field only) and 3 mm mounting hardware included			
Environmental Rating	Rated IEC IP67; NEMA 6; UL Type 1			
Connections	2 m or 9 m 4-wire PVC cable, or 4-pin 150 mm pigtail Pico-style QD (Q), or 4-pin 150 mm pigtail Euro-style QD (Q5), or 4-pin Integral Pico-style QD (Q7), or 4-pin Integral Euro-style QD (Q8), depending on model. QD cordsets are ordered separately. See page 51.			
Operating Conditions	Temperature:	Lasers -10° to +50° C	Adjustable-Field LED (100 mm) 0° to +55° C	Adjustable-Field LED (40, 200 & 300 mm) -20° to +55° C
	Relative humidity:	90% @ 50° C (non-condensing)	95% @ 50° C (non-condensing)	95% @ 50° C (non-condensing)
Laser Classification (Laser models only)	Class 1 and Class 2 laser product; complies with IEC 60825-1: 2001 and 21 CFR 1040.10, except deviations pursuant to Laser Notice 50, dated 7-26-01.			
Application Notes	AF models: NPN off-state leakage current is < 200 µA for load resistances > 3 kΩ or optically isolated loads. For load current of 100 mA, leakage is < 1% of load current			
Certifications	All others:   Laser Emitters: 			

* Does not apply to laser emitter models.

QS18 *Expert*TM Specifications and Clear Object Specifications

Supply Voltage	10 to 30 V dc (10% max. ripple) at less than 35 mA, exclusive of load; 10 to 24 V dc @ greater than 55° C
Supply Protection Circuitry	Protected against reverse polarity and transient voltages
Output Configuration	Solid-state NPN (current sinking) or PNP (current sourcing), depending on model Light (LO) or Dark Operate (DO) selectable Selectable 30 millisecond output OFF-delay Rating: 100 mA max. OFF-state leakage current: less than 50 µA @ 30 V dc ON-state saturation voltage: less than 1.5 V (2 m cable); 1.7 V (9 m cable) Protected against false pulse on power-up and continuous overload or short circuit of output
Output Response Time	Expert: 600 microseconds ON/OFF Clear Object Detection: 400 microseconds ON/OFF
Delay at Power-up	Momentary delay on power-up; outputs do not conduct during this time
Repeatability	Expert: 75 microseconds Clear Object Detection: 100 microseconds
Adjustments	Thresholds: Push-button/remote-wire configurable ExpertTM-style TEACH and SET options: Light/Dark Operate: selectable by programming order (load output follows the first taught target condition) Push-button enable/disable: remote wire only See datasheet for detailed information
Indicators	2 LED indicators: Green: RUN mode, output short-circuit Yellow: Output ON/marginal, TEACH mode
Construction	ABS housing
Environmental Rating	Meets NEMA 6; IEC IP67; UL Type 1
Connections	2 m or 9 m 4-wire PVC cable, or 4-pin 150 mm pigtail Pico-style QD (Q), or 4-pin 150 mm pigtail Euro-style QD (Q5), or 4-pin Integral Pico-style QD (Q7), or 4-pin Integral Euro-style QD (Q8). QD cordsets are ordered separately. See page 51.
Operating Conditions	Temperature: -20° to +70° C Relative humidity: 90% @ 50° C (non-condensing)
Certifications	

QS18 Universal Voltage Specifications

Supply Voltage	P-MOSFET Models: 20 to 140 V ac/dc @ < 10 mA, exclusive of load N-MOSFET Models: 20 to 270 V ac/dc @ < 10 mA, exclusive of load	
Supply Protection Circuitry	Protected against reverse polarity and transient over-voltages	
Output Configuration	Single Discrete Output, 100 mA load rating N-MOSFET or P-MOSFET , depending on model number Light Operate or Dark Operate, depending on model number	
Output Rating	P-MOSFET models 100 mA with short circuit protection OFF-state leakage current: < 400 µA ON-state saturation voltage: 2.75 V	N-MOSFET models 100 mA with short circuit protection OFF-state leakage current: < 400 µA ON-state saturation voltage: 2.5 V
Output Protection Circuitry	Protected against output short-circuit and false pulse on power up. Latching short-circuit protection; reset by cycling power	
Delay at Power-up	100 milliseconds max. dc, 300 milliseconds max. ac; outputs do not conduct during this time	
Repeatability	1.5 milliseconds	
Output Response Time	Opposed mode: 16.6 milliseconds (1 cycle at 60 Hz) All other modes: 8.3 milliseconds (½ cycle at 60 Hz)	
Adjustments	Diffuse, Retroreflective and Polarized Retroreflective models only: 1-turn potentiometer Sensitivity (Gain) adjustment	
Indicators	Green: Power ON Yellow: Light Sensed	
Construction	Housing: ABS Lenses: PMMA Gain Adjuster: Acetal	
Environmental Rating	IEC IP67 (NEMA 6); 1200 PSI washdown NEMA ICS5, Annex F-2002 (PW12); UL Type 1	
Connections	2 m 3-conductor, 22 AWG PVC cable (300 V ac), or 150 mm pigtail PVC cable with 4-pin threaded Micro-style connector; C1 suffix models: 2 m 3-conductor, 22 AWG PVC cable (600 V ac)	
Operating Conditions	Temperature: Less than 140 V ac/dc: -25° to +70° C (N-MOSFET and P-MOSFET models) 140 V ac/dc or greater: -25° to +55° C (N-MOSFET models only) Max. Relative Humidity: 95% @ 55° C (non-condensing)	
Certifications		

QS30 Series

High-Performance, Long-Range Sensors



- Right-angle, barrel- and side-mount sensors
- Specialized models for reliable detection of water or liquids containing water
- Specialized photoelectric sensors that have the ability to differentiate colors in low contrast applications
- Cordsets and brackets see page 62



QS30

page 56

Eight sensing modes for solving most applications: opposed, retroreflective, convergent, diffuse, plastic and glass fiber optic, and adjustable-field and fixed-field. High-performance sensing with visible, long-range Class 1 and 2 lasers with narrow effective beam for small object detection and precise position control.



QS30 Water Detection

page 58

The QS30 Water Sensors have an infrared wavelength that is tuned to the absorption band of water.



QS30 Expert™

page 59

Single push-button programming with five advanced sensing options for reliable detection of reflective objects.



QS30 Adjustable-Field page 60

Background suppression models for detection of objects when the background condition is not fixed, and foreground suppression models for detection when background is fixed and object varies in color or shape.



QS30 Universal Voltage page 61

Compact ac or dc powered sensor can be used in almost any mounting configuration, including 18 mm barrel, base or side mounting.

QS30

DC-Operated Long-Range Sensors



- The QS30 DC sensor is a specialized photoelectric sensor that has high performance and long range with a consistent voltage source.
- Ability to work reliably in low contrast applications
- Ability to detect liquid in translucent and opaque bottles
- Rated to IP67 for use in harsh environments
- Cordsets and brackets see page 62

Opposed QS30

Infrared LED

Sensing Mode	Range	Connection	Output Type	Model
	60 m	2 m 5-pin Euro QD	Bipolar NPN/PNP	QS30E Emitter*
		2 m 5-pin Euro QD		QS30EQ Emitter*
	213 m	2 m 5-pin Euro QD	Bipolar NPN/PNP LO	QS30EX Emitter
		2 m 5-pin Euro QD		QS30EXQ Emitter
		2 m 5-pin Euro QD	Bipolar NPN/PNP DO	QS30ARX
		2 m 5-pin Euro QD		QS30ARRX



Case Entry Detection Using Polar Retroreflective Sensors

The QS30LP verifies that there is a box present to be picked up before being sent to the palletizer. Shrink wrap is placed around the boxes on the pallet before being shipped.

Retro & Polar Retro QS30

Visible Red LED

Sensing Mode	Range	Connection	Output Type	Model
	12 m†	2 m 5-pin Euro QD	Bipolar NPN/PNP	QS30LV
		2 m 5-pin Euro QD		QS30LVQ
	8 m†	2 m 5-pin Euro QD	Bipolar NPN/PNP	QS30LP
		2 m 5-pin Euro QD		QS30LPQ

For more specifications see page 63.

Connection options: A model with a QD requires a mating cordset (see page 62).

For 9 m cable, add suffix W/30 to the 2 m model number (example, QS30R W/30).

* Standard emitters will only work with standard receivers.

† Retroreflective range is specified using one model BRT-84 retroreflector.

Diffuse QS30

 Infrared LED

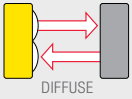
Sensing Mode	Range	Connection	Output Type	Model
 DIFFUSE	1 m	2 m	Bipolar NPN/PNP	QS30D
		5-pin Euro QD		QS30DQ

Fixed-Field QS30

 Visible Red LED

Sensing Mode	Range	Connection	Output Type	Model
 FIXED-FIELD	200 mm Cutoff	2 m	Bipolar NPN/PNP	QS30FF200
		5-pin Euro QD		QS30FF200Q
 FIXED-FIELD	400 mm Cutoff	2 m	Bipolar NPN/PNP	QS30FF400
		5-pin Euro QD		QS30FF400Q
 FIXED-FIELD	600 mm Cutoff	2 m	Bipolar NPN/PNP	QS30FF600
		5-pin Euro QD		QS30FF600Q

For more specifications see page 63.

 Connection options: A model with a QD requires a mating cordset (see page 62).

For 9 m cable, add suffix W/30 to the 2 m model number (example, QS30D W/30).

* Super High-Power emitters will only work with Super High-Power receivers.

† Sensors can be used at ranges greater than listed for applications that require less excess gain. Please consult the factory for assistance on your long-range applications. Actual sensing range may differ, depending on the efficiency and reflective area of the retroreflector used. See Accessories for more information.

QS30 Water Detection

DC-Operated Long-Range Sensors



- Ability to work reliably in low contrast applications
- Ability to detect liquid in translucent and opaque bottles
- Cordsets and brackets see page 62

Opposed Water Detection QS30

Infrared LED

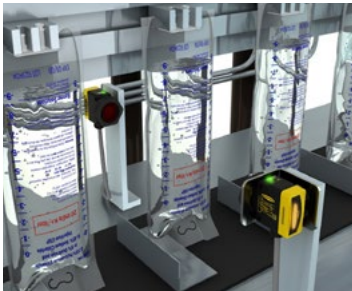

Detection of Clear Liquids in Transparent Packaging

The QS30H2O effectively and accurately detects the presence or absence of water inside clear IV bags.

Sensing Mode	Range	Connection	Output Type	Model
<p>OPPOSED WATER DETECTION</p>	4 m†	2 m	—	QS30EXH2O Emitter*
		5-pin Euro Pigtail QD	—	QS30EXH2OQ5 Emitter*
		2 m	Bipolar NPN/PNP	QS30ARXH2O
		5-pin Euro Pigtail QD	LO	QS30ARXH2OQ5
		2 m	Bipolar NPN/PNP	QS30RRXH2O
		5-pin Euro Pigtail QD	DO	QS30RRXH2OQ5
<p>OPPOSED WATER DETECTION</p>	2 m	2 m	Analog 0-10 V	QS30RXH20U
		5-pin Euro Pigtail QD	Analog 0-10 V	QS30RXH20UQ5
		2 m	Bipolar NPN/PNP	QS30ARH2O
		5-pin Euro Pigtail QD	LO	QS30ARH2OQ5
<p>OPPOSED WATER DETECTION</p>	2 m	2 m	Bipolar NPN/PNP	QS30RRH2O
		5-pin Euro Pigtail QD	DO	QS30RRH2OQ5
		2 m	Bipolar NPN/PNP	QS30EXSH2O Emitter*
		5-pin Euro Pigtail QD	—	QS30EXSH2OQ5 Emitter*
<p>SUPER HIGH-POWER OPPOSED WATER DETECTION</p>	8 m†	2 m	Bipolar NPN/PNP	QS30ARXSH2O
		5-pin Euro Pigtail QD	LO	QS30ARXSH2OQ5
		2 m	Bipolar NPN/PNP	QS30RRXSH2O
		5-pin Euro Pigtail QD	DO	QS30RRXSH2OQ5

For more specifications see page 63.

Connection options: A model with a QD requires a mating cordset (see page 62).

For 9 m cable, add suffix W/30 to the 2 m model number (example, QS30D W/30).

* Super High-Power emitters will only work with Super High-Power receivers.

† Sensors can be used at ranges greater than listed for applications that require less excess gain. Please consult the factory for assistance on your long-range applications. Actual sensing range may differ, depending on the efficiency and reflective area of the retroreflector used. See Accessories for more information.

QS30 Expert™

DC-Operation with Push-Button Programming



- The QS30 Expert™ has high-performance sensing for challenging applications and is easy to align with an 8-segment LED bargraph.
- Available in laser retroreflective, diffuse, laser diffuse and retroreflective sensing modes
- Visible red LED or laser for easy alignment
- Models available for small object detection and precision control
- Cordsets and brackets see page 62

Diffuse QS30 Expert™

➔ Visible Red LED ✨ Visible Red Laser

Sensing Mode	Laser Class	Range	Connection	Model
DIFFUSE	—	High-Speed: 1100 mm Normal: 1400 mm	2 m 5-pin Euro QD	QS30EDV QS30EDVQ
DIFFUSE LASER	Class 1	400 mm	2 m 5-pin Euro QD	QS30LD QS30LDQ
DIFFUSE LASER	Class 2	800 mm	2 m 5-pin Euro QD	QS30LDL QS30LDLQ

TEACH Mode

Sensors can be configured via any of five TEACH or SET options (by push button or the remote wire) to define the sensing limits. Sensing limit configuration options include:

- **Static TEACH:** one switching threshold, determined by two taught conditions
- **Dynamic (on-the-fly) TEACH:** one switching threshold, determined by multiple sampled conditions
- **Light SET and Dark SET:** one switching threshold, offset from a single sensing condition (the “dark” condition or the “light” condition)
- **Window SET:** a sensing window, centered around a single sensing condition

Laser Retro & Polar Retro QS30 Expert™

➔ Visible Red LED ✨ Visible Red Laser

Sensing Mode	Laser Class	Range	Connection	Model
LASER POLAR RETRO	Class 1	0.2-18 m†	2 m 5-pin Euro QD	QS30LLP QS30LLPQ
LASER POLAR RETRO	Class 1 (low contrast)	0.2-18 m†	2 m 5-pin Euro QD	QS30LLPC QS30LLPCQ
CLEAR OBJECT RETRO	—	100 mm to 2 m††	2 m 5-pin Euro QD	QS30ELVC QS30ELVCQ

For more specifications see page 64.

➔ Connection options: A model with a QD requires a mating cordset (see page 62).
For 9 m cable, add suffix W/30 to the 2 m model number (example, QS30EDV W/30).

QS30 Adjustable-Field

Background and Foreground Suppression



- Foreground suppression models for detection when background is fixed and the object varies in color or shape
- Background suppression models for detection of objects when the background condition is not fixed
- Fluorescent light and crosstalk avoidance for reliable sensing
- Long range for reliable sensing up to 600 mm
- Cordsets and brackets see page 62

Adjustable-Field Foreground Suppression

- Foreground suppression models for reliable detection when a fixed background is present and the object color or shape varies
- Objects detected to the face of the sensor (no dead zone)
- Simple multiturn screw adjustment of the cutoff distance
- Enhanced immunity to fluorescent lights
- Crosstalk immunity algorithm allows two sensors to be used in close proximity
- Visible red emitter

Adjustable-Field Background Suppression

- Background suppression models detect objects of various color, and ignores objects beyond their cutoff range
- Simple multiturn screw adjustment of the cutoff distance
- Enhanced immunity to fluorescent lights
- Crosstalk immunity algorithm allows two sensors to be used in close proximity
- Visible red emitter

Foreground Suppression QS30

➔ Visible Red LED

Sensing Mode	Range	Connection	Output Type	Model
	Adjustable between 50-400 mm	2 m	Bipolar NPN/PNP	QS30AFF400
		5-pin Euro QD		QS30AFF400Q

Background Suppression QS30 Adjustable-Field

➔ Visible Red LED

Sensing Mode	Range	Connection	Output Type	Model
	Adjustable between 50-300 mm	2 m	Bipolar NPN/PNP	QS30AF
		5-pin Euro QD		QS30AFQ
	Adjustable between 50-600 mm	2 m	Bipolar NPN/PNP	QS30AF600
		5-pin Euro QD		QS30AF600Q

For more specifications see page 65.

➔ Connection options: A model with a QD requires a mating cordset (see page 62).

For 9 m cable, add suffix W/30 to the 2 m model number (example, QS30AFF400 W/30).

QS30 Universal Voltage

Versatile Sensors Operate on AC or DC Voltage



- The QS30 Universal Sensor is a versatile, specialized sensor for use in many environments regardless of supply voltage
- Right-angle, barrel- and side-mount sensors
- Cordsets and brackets see page 62

Opposed QS30, 12-250 V DC or 24-250 V AC

Infrared LED

Sensing Mode	Range	Connection	Output Type	Model
 OPPOSED	60 m	2 m	—	QS303E Emitter
		2 m	SPDT e/m Relay	QS30VR3R

Polar Retro QS30, 12-250 V DC or 24-250 V AC

Visible Red LED

Sensing Mode	Range	Connection	Output Type	Model
 POLAR RETRO	8 m [†]	2 m	SPDT e/m Relay	QS30VR3LP

Fixed-Field QS30, 12-250 V DC or 24-250 V AC

Visible Red LED

Sensing Mode	Range	Connection	Output Type	Model
 FIXED-FIELD	200 mm Cutoff	2 m	SPDT e/m Relay	QS30VR3FF200
	400 mm Cutoff	2 m	SPDT e/m Relay	QS30VR3FF400
	600 mm Cutoff	2 m	SPDT e/m Relay	QS30VR3FF600

For more specifications see page 64.

Connection options: A model with a QD requires a mating cordset (see page 62).

For 9 m cable, add suffix W/30 to the 2 m model number (example, QS303E W/30).

QD models: Available with modified specification, contact factory at 1-888-373-6767.

[†] Retroreflective range is specified using one model BRT-84 retroreflector.
Actual sensing range may differ, depending on the efficiency and reflective area of the retroreflector used. See Accessories for more information.

**Euro QD
(for Q models)**
Straight connector models listed; for right-angle, add **RA** to the end of the model number (example, **MQDC-506RA**)



5-Pin
MQDC1-506
2 m (6.5')
MQDC1-515
5 m (15')
MQDC1-530
9 m (30')

Reflectors



*Additional information is available
See page 790*

Apertures



*Additional information is available
See page 816*

*Additional cordset information is available
See page 758*



SMBQS30L



SMBQS30Y



SMBQS30YL



SMB30A

*Additional bracket information is available
See page 722*



Opposed, Retroreflective, Diffuse,
Fixed-Field and Expert Models
Suffix E, R, LP, LV, D, AF, FF, LLP, LLPC,
LVC, EDV, LD and LDL



Opposed High-Power Models
Suffix EX and RX



Adjustable-Field, Fixed-Field and
Universal Voltage Models
Suffix AFF, FF, R, E, LP



QS30 Specifications

Supply Voltage and Current	Emitters (High-Power): 10 to 30 V dc (10% max. ripple) at less than 70 mA Receivers (High-Power): 10 to 30 V dc (10% max. ripple) at less than 22 mA Analog Receivers (water): 15 to 30 V dc (10% max. ripple) at less than 65 mA All others: 10 to 30 V dc (10% max. ripple) at 40 mA, (exclusive of load)	Emitters (Water): 10 to 30 V dc (10% max. ripple) at less than 80 mA Receivers (Water): 10 to 30 V dc (10% max. ripple) at less than 65 mA (exclusive of load)
Supply Protection Circuitry	Protected against reverse polarity and transient voltages	
Output Configuration	Bipolar: One PNP (current sourcing) and one NPN (current sinking); Light Operate (LO) or Dark Operate (DO) selectable or configurable (depending on model)	
Output Response Time	Opposed: 5 milliseconds ON/OFF Opposed (High-Power): 30 milliseconds ON/OFF Opposed (Water): 10 x excess gain or more– Standard: 1 millisecond ON/OFF 2x to 10x excess gain– Standard: 3 milliseconds ON/OFF All others: 2 milliseconds ON/OFF	Super High-Power: 10 milliseconds ON/OFF Super High-Power: 30 milliseconds ON/OFF
Delay at Power-Up	100 milliseconds; outputs do not conduct during this time (except Opposed High-Powered and Water)	
Repeatability	Opposed: not applicable Opposed (High-Power): 5 milliseconds Opposed (Water): 10 x excess gain or more– Standard: 500 microseconds 2x to 10x excess gain– Standard: 2.5 milliseconds All others: 500 microseconds	Super High-Power: 5 milliseconds Super High-Power: 25 milliseconds
Adjustments	Opposed (High-Power and Water): Light Operate/Dark Operate–dependent on model selected Frequency via gray wire: A: Gray (+) B: Gray (-) Emitter only: LED inhibit, via white wire White (-) turns emitter LED OFF (to allow verification of sensor operation) Opposed, Retroreflective, and Polarized Retroreflective: Selectable Light/Dark Operate is achieved via the gray wire Light Operate: Low (0 to 3 V)* Dark Operate: High (open or 5 to 30 V)* Diffuse: Selectable Light/Dark Operate is achieved via the gray wire Light Operate: High (open or 5 to 30 V)* Dark Operate: Low (0 to 3 V)* Diffuse, Retroreflective, and Polarized Retroreflective (only): Single-turn sensitivity (Gain) adjustment potentiometer * Input impedance 10 kΩ See datasheet for more detailed information	
Indicators	Opposed (High-Power): 4-LED Signal Strength light bar Green LED: Power ON Frequency indicator: (A or B) Receiver only: Yellow LED: Output conducting All others (except emitters): Large, oval LED indicator on sensor back Yellow: Output conducting Small indicator on back (adjustable-field only) Blue/Red: End of travel (EOT) LED 2 indicators on top Green: Power ON Yellow: Light sensed	
Construction	ABS plastic housing; acrylic lens cover Opposed High-Power Lenses: Impact resistant lens material	
Environmental Rating	Opposed (High-Power): Cabled: IP67; NEMA 6P Opposed (High-Power) QD: IP69K per DIN 40050-9 Opposed (Water): IEC IP67 (nema 6); PW12 1200 PSI washdown per NEMA PW12 All others: IP67; NEMA 6	
Connections	5-conductor 2 m or 9 m PVC cable, or 5-pin 150 mm pigtail or integral Euro-style quick-disconnect fitting, depending on model. QD cordsets are ordered separately. See page 62.	
Operating Conditions	Opposed (Water), Opposed (High-Power): -20° to +60° C All others: -20° to +70° C	Relative humidity: 90% (non-condensing) Relative humidity: 90% (non-condensing)
Certifications		

QS30 Expert™ Specifications

Supply Voltage and Current	Diffuse LED and Retroreflective LED: 10 to 30 V dc (10% max. ripple) at less than 25 mA, exclusive of load Diffuse Laser and Retroreflective Laser: 10 to 30 V dc (10% max. ripple @ 10% duty cycle) @ 35 mA max current, exclusive of load
Output Protection Circuitry	Protected against output short-circuit, continuous overload, transient over-voltages and false pulse on power-up
Sensing Beam	LED models: 660 nm visible Red Laser models: Class 1: 650 nm visible Red Class 2: 658 nm visible Red
Beam Size at Aperture	Diffuse Laser: Approx. 2 mm Retroreflective Laser: Approx. 3 mm
Output Configuration	Bipolar: One NPN (current sinking) and one PNP (current sourcing); Light Operate (LO) or Dark Operate (DO) configurable
Output Response Time	Diffuse LED: High-speed mode: 300 microseconds Normal mode: 1.8 milliseconds Diffuse Laser, Retroreflective Laser and Retroreflective LED: 500 microseconds
Delay at Power-up	Diffuse LED and Retroreflective LED: 250 milliseconds; outputs do not conduct during this time Diffuse Laser and Retroreflective Laser: 1 second max.; outputs do not conduct during this time
Repeatability	Diffuse LED: High-speed mode: 100 microseconds Normal mode: 150 microseconds Retroreflective LED: 150 microseconds Diffuse Laser and Retroreflective Laser: 70 microseconds
Adjustments	2 push buttons and remote wire for TEACH programming and configuration See datasheet for detailed information
Indicators	2 LEDs: Green: Power ON Yellow: Output conducting See datasheets for more detailed information
Construction	PC/ABS housing with acrylic lens cover
Environmental Rating	Retroreflective LED: IEC IP67 (NEMA 6); PW12 1200 PSI washdown All others: IP67; NEMA 6
Connections	5-conductor 2 m or 9 m attached PVC cable, or 5-pin Euro-style quick-disconnect fitting. QD cordset are ordered separately. See page 62.
Operating Conditions	Diffuse LED and Retroreflective LED: Temperature: -10° to +55° C Relative humidity: 95% @ 55° C (non-condensing) Diffuse Laser and Retroreflective Laser: Temperature: -10° to +50° C Relative humidity: 95% @ 50° C (non-condensing)
Application Note	QS30ELVC models: If supply voltage is > 24 V dc, derate maximum output current 1 mA/°C above 25°C
Certification	

QS30 Universal Voltage Specifications

Supply Voltage	24 to 250 V ac, 50/60 Hz or 12 to 250 V dc (1.0 watt max.)
Supply Protection Circuitry	Protected against transient voltages
Output Configuration	SPDT (Single-Pole Double-Throw) electromechanical relay output (all models except emitters)
Output Response Time	15 milliseconds ON/OFF
Delay at Power-Up	100 millisecond delay; output does not conduct during this time
Indicators	2 LED indicators on sensor top: Green: Power ON Yellow: Light sensed Large, oval LED indicator on sensor back (except emitters): Yellow: Output conducting See datasheet for detailed information
Construction	ABS housing; acrylic lens cover
Environmental Rating	IEC IP67; NEMA 6
Connections	2 m or 9 m 5-wire PVC cable
Operating Conditions	Temperature: -20° to +70° C Relative humidity: 95% @ 50° C (non-condensing)
Certifications	 

QS30 Adjustable-Field Specifications

Supply Voltage	10 to 30 V dc (10% max. ripple); current consumption: AF600 & AFF400 models: Less than 80 mA at 10 V dc, less than 40 mA at 30 V dc AF models: 45 mA max current
Supply Protection Circuitry	Protected against reverse polarity and transient voltages
Delay at Power-Up	AF600 & AFF400 models: 200 milliseconds; outputs do not conduct during this time AF models: 250 milliseconds; outputs do not conduct during this time
Output Configuration	Bipolar: One PNP (current sourcing) and one NPN (current sinking)
Output Rating	AF600 & AFF400 models: 100 mA total output current (derate 1 mA per °C above 30° C) OFF-state leakage current: less than 5 µA @ 30 V dc ON-state saturation voltage: NPN: less than 1.5 V @ 100 mA PNP: less than 2.0 V @ 100 mA AF models: 150 mA total output current (derate 1 mA per °C above 25° C) OFF-state leakage current: less than 50 µA @ 30 V dc ON-state saturation voltage: NPN: less than 200 mV @ 10 mA; less than 1 V @ 150 mA PNP: less than 1.25 V @ 10 mA; less than 2 V @ 150 mA
Output Protection	Protected against false pulse on power-up and continuous overload or short circuit of outputs
Output Response Time	AF600 & AFF400 models: 5 milliseconds ON/OFF AF models: 1 millisecond ON/OFF
Repeatability	AF600 & AFF400 models: 750 microseconds AF models: 170 microseconds
Adjustments	AF600 & AFF400 models: Four-turn adjustment screw sets cutoff distance between min. and max. positions, clutched at both ends of travel AF models: 2 push buttons and remote wire <ul style="list-style-type: none"> • Easy push-button configuration • Manually adjust (+/-) cutoff (push buttons only) • N.O./N.C. and OFF-delay configuration options (push buttons only) • Push-button lockout (from remote wire only) 2 push buttons or LO/DO adjustment
Indicators	AF600 & AFF400 models: Large, oval LED indicator on sensor back Yellow: Output conducting Small indicator on back Blue/Red: End of travel (EOT) LED 2 indicators on top Green: Power ON Yellow: Light sensed AF models: 8-segment red bargraph: Distance relative to cutoff point Green LED: Power ON Yellow LED: Output conducting
Construction	ABS plastic housing; acrylic lens cover
Environmental Rating	IEC IP67; NEMA 6
Connections	5-conductor 2 m or 9 m PVC cable, or 5-pin 150 mm pigtail or integral Euro-style quick-disconnect fitting, depending on model. QD cordsets are ordered separately. See page 62.
Operating Conditions	AF600 & AFF400 models: -20° to +60° C; 95% relative humidity @ 50° C (non-condensing) AF models: -10° to +55° C; 90% relative humidity @ 55° C (non-condensing)
Vibration and Mechanical Shock	All models meet Mil. Std. 202F requirements. Method 201A (Vibration: 10 to 60 Hz max. double amplitude 0.06", max. acceleration 10G). Also meets IEC 947-5-2 requirements: 30G, 11 milliseconds duration, half sine wave.
Certifications	

Q12 Series

Miniature Self-Contained Sensors



- The Q12 sensor is a small sensor with high performance for powerful sensing in confined spaces.
- Overmolded housing
- Short-range background suppression
- Cordsets and brackets see page 68

Opposed Q12

➔ Visible Red LED

Sensing Mode	Range	Connection	Output	Models LO*	Models DO*
<p>OPPOSED</p>	2 m	2 m	-	Q126E Emitter	
		4-Pin Pico Pigtail QD	-	Q126EQ Emitter	
		3-Pin Pico Pigtail QD	-	Q126EQ3 Emitter	
<p>OPPOSED</p>	2 m	2 m	Bipolar NPN/PNP	Q12AB6R	Q12RB6R
		4-Pin Pico Pigtail QD	Bipolar NPN/PNP	Q12AB6RQ	Q12RB6RQ
		3-Pin Pico Pigtail QD	PNP	Q12AP6RQ3	Q12RP6RQ3
		3-Pin Pico Pigtail QD	NPN	Q12AN6RQ3	Q12RN6RQ3

Retro & Polar Retro Q12

➔ Visible Red LED

Sensing Mode	Range	Connection	Output	Models LO*	Models DO*
<p>RETRO</p>	1.5 m [†]	2 m	Bipolar NPN/PNP	Q12AB6LV	Q12RB6LV
		4-Pin Pico Pigtail QD	Bipolar NPN/PNP	Q12AB6LVQ	Q12RB6LVQ
		3-Pin Pico Pigtail QD	PNP	Q12AP6LVQ3	Q12RP6LVQ3
		3-Pin Pico Pigtail QD	NPN	Q12AN6LVQ3	Q12RN6LVQ3
<p>POLAR RETRO</p>	1 m [†]	2 m	Bipolar NPN/PNP	Q12AB6LP	Q12RB6LP
		4-Pin Pico Pigtail QD	Bipolar NPN/PNP	Q12AB6LPQ	Q12RB6LPQ
		3-Pin Pico Pigtail QD	PNP	Q12AP6LPQ3	Q12RP6LPQ3
		3-Pin Pico Pigtail QD	NPN	Q12AN6LPQ3	Q12RN6LPQ3

For more specifications see page 69.

Connection options:

Bipolar Models Only: For 9 m cable, add suffix W/30 to the 2 m model number (example, Q126E W/30).

QD models: A model with a QD requires a mating cordset (see page 68).

For 4-pin 150 mm Euro-style QD, add suffix Q5 (example, Q126EQ5).

* For black housing, add prefix D to the model number, for example, DQ12AB6R

† Retroreflective range is specified using a BRT-60X40C retroreflector.

Actual sensing range may differ, depending on the efficiency and reflective area of the retroreflector used. See Accessories for more information.

Fixed-Field Q12

➔ Visible Red LED

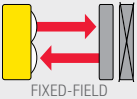
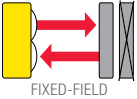
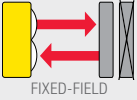
Sensing Mode	Range	Connection	Output	Models LO*	Models DO*
 <p>FIXED-FIELD</p>	15 mm Cutoff	2 m	Bipolar NPN/PNP	Q12AB6FF15	Q12RB6FF15
		4-Pin Pico Pigtail QD	Bipolar NPN/PNP	Q12AB6FF15Q	Q12RB6FF15Q
		3-Pin Pico Pigtail QD	PNP	Q12AP6FF15Q3	Q12RP6FF15Q3
		3-Pin Pico Pigtail QD	NPN	Q12AN6FF15Q3	Q12RN6FF15Q3
 <p>FIXED-FIELD</p>	30 mm Cutoff	2 m	Bipolar NPN/PNP	Q12AB6FF30	Q12RB6FF30
		4-Pin Pico Pigtail QD	Bipolar NPN/PNP	Q12AB6FF30Q	Q12RB6FF30Q
		3-Pin Pico Pigtail QD	PNP	Q12AP6FF30Q3	Q12RP6FF30Q3
		3-Pin Pico Pigtail QD	NPN	Q12AN6FF30Q3	Q12RN6FF30Q3
 <p>FIXED-FIELD</p>	50 mm Cutoff	2 m	Bipolar NPN/PNP	Q12AB6FF50	Q12RB6FF50
		4-Pin Pico Pigtail QD	Bipolar NPN/PNP	Q12AB6FF50Q	Q12RB6FF50Q
		3-Pin Pico Pigtail QD	PNP	Q12AP6FF50Q3	Q12RP6FF50Q3
		3-Pin Pico Pigtail QD	NPN	Q12AN6FF50Q3	Q12RN6FF50Q3

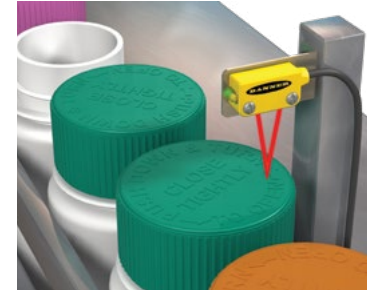

Bottle Cap Detection Using Fixed-Field Sensors

As bottle caps pass below the fixed-field beam identifies bottle caps regardless of color and rejects bottles missing caps.

PFA-Jacketed Q12

➔ Visible Red LED

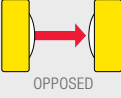
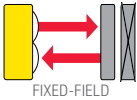
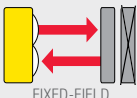
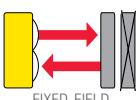
Sensing Mode	Range	Connection	Output	Models LO	Models DO
 <p>OPPOSED</p>	1.5 m	2 m	Bipolar NPN/PNP	Q12AB6RCR	Q12RB6RCR
 <p>FIXED-FIELD</p>	12 mm Cutoff	2 m	Bipolar NPN/PNP	Q12AB6FF15CR	Q12RB6FF15CR
 <p>FIXED-FIELD</p>	28 mm Cutoff	2 m	Bipolar NPN/PNP	Q12AB6FF30CR	Q12RB6FF30CR
 <p>FIXED-FIELD</p>	48 mm Cutoff	2 m	Bipolar NPN/PNP	Q12AB6FF50CR	Q12RB6FF50CR

For more specifications see page 69.

Connection options:

Bipolar Models Only: For 9 m cable, add suffix W/30 to the 2 m model number (example, Q12RB6FF15 W/30).
 QD models: A model with a QD requires a mating cordset (see page 68).
 For 4-pin 150 mm Euro-style QD, add suffix Q5 (example, Q12RB6FF15Q5).

* For black housing, add prefix D to the model number, for example, DQ12AB6R
 Actual sensing range may differ, depending on the efficiency and reflective area of the retroreflector used. See Accessories for more information.



Euro QD (for Q5 models)
Straight connector models listed; for right-angle, add **RA** to the end of the model number (example, **MQDC-406RA**)

4-Pin
MQDC-406
2 m (6')
MQDC-415
5 m (15')
MQDC-430
9 m (30')



Pico QD (for Q and Q3 models)
Straight connector models listed; for right-angle, **W** replaces **G** in the model number. (example, **PKW4M-2**)

3-Pin	4-Pin
PKG3M-2 2 m (6.5')	PKG4M-2 2 m (6.5')
PKG3M-5 5 m (15')	PKG4M-5 5 m (15')
PKG3M-7 7 m (23')	-
PKG3M-9 9 m (30')	PKG4M-9 9 m (30')
PKG3M-10 10 m (32')	-

Additional cordset information is available
See page 758



SMBQ12T



SMBQ12A

Additional bracket information is available
See page 722

Reflectors



Additional information is available
See page 790

Apertures



Additional information is available
See page 816



Opposed, Retroreflective and Fixed-Field Models
Suffix E, R, LV and FF

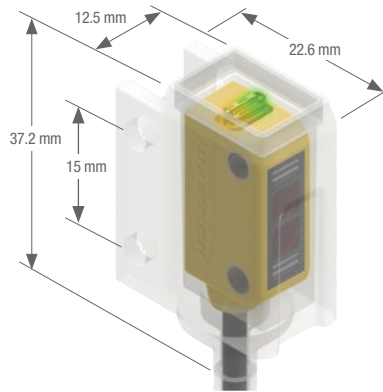

Chemical-Resistant Models
Suffix CR

Q12 Specifications

Sensing Beam	640 nm visible red
Supply Voltage and Current	10 to 30 V dc (10% max. ripple) @ 20 mA max. current
Supply Protection Circuitry	Protected against reverse polarity and transient voltages
Output Configuration	Bipolar: 1 NPN (current sinking) and 1 PNP (current sourcing); Light Operate (LO) or Dark Operate (DO), depending on model Single-output: 1 NPN or 1 PNP; Light Operate (LO) or Dark Operate (DO), depending on model
Output Rating	50 mA total across both outputs with overload and short circuit protection OFF-state leakage current: ON-state saturation voltage: NPN: 200 μ A NPN: 1.25 V @ 50 mA PNP: 10 μ A PNP: 1.45 V @ 50 mA
Output Protection Circuitry	Protected against false pulse on power-up; short-circuit protected
Output Response Time	Opposed: 1.3 milliseconds ON; 900 microseconds OFF All others: 700 microseconds ON/OFF
Delay at Power-up	120 milliseconds; outputs do not conduct during this time
Repeatability	175 microseconds
Switching Frequency	Opposed models: 385 Hz All other models: 715 Hz
Indicators	2 LED indicators (Emitters-Green only): Green — Power ON Yellow — Light sensed
Construction	Polarized Retroreflective: Thermoplastic elastomer housing with glass lens Standard: Thermoplastic elastomer housing with polycarbonate lens Chemical-resistant: Housing encased in PFA jacket; cable encased in 3/16" O.D. PFA tubing
Environmental Rating	Standard: IEC IP67 Chemical-resistant: IEC IP67 (NEMA 6) and PW12 1200 psi washdown per NEMA ICS 5, Annex F-2002
Connections	Bipolar: 2 m or 9 m attached PVC cable, or 150 mm pigtail with 4-pin Pico-style (Q) or 4-pin Euro-style (Q5) quick-disconnect fitting. QD cordsets are ordered separately. See page 68. Single output: 150 mm pigtail with 3-pin Pico-style (Q3) quick-disconnect fitting. QD cordsets are ordered separately. See page 68. Chemical-resistant: 2 m attached cable encased in 3/16" O.D. PFA tubing
Operating Conditions	Temperature: -20° to +55° C Storage temperature: -30° to +75° C Relative humidity: 95% max. @ 50° C (non-condensing)
Certifications	

Q20 Series

Industry Standard Global Housing



- The Q20 is a versatile sensor with a universal rectangular housing and multiple mounting options, making it ideal for global manufacturing
- Rated to 1200 psi for use in washdown environments
- Enhanced design for noise immunity and crosstalk avoidance
- Visible red beam for easy alignment on most models
- Cordsets and brackets see page 68

Opposed Q20

⇨ Infrared LED → Visible Red LED

Sensing Mode	Range	Connection	Models NPN*	Models PNP*
 OPPOSED	12 m	2 m 4-pin Euro Pigtail QD 2 m 4-pin Euro Pigtail QD	Q20NR Q20NRQ5	Q20PR Q20PRQ5
 OPPOSED	20 m	2 m 4-pin Euro Pigtail QD 2 m 4-pin Euro Pigtail QD	Q20NRL Q20NRLQ5	Q20PRL Q20PRLQ5



Unfinished Can Detection Using Polar Retro Sensors

When the unfinished cans pass between the sensor and the retroreflector, the light reflected off the cans has a different polarization than the light returned by the retroreflector. As a result, the beam will be blocked by the cans and the output will be triggered.

Retro & Polar Retro Q20

→ Visible Red LED

Sensing Mode	Range	Connection	Models NPN*	Models PNP*
 RETRO	6 m†	2 m 4-pin Euro Pigtail QD	Q20NLV Q20NLVQ5	Q20PLV Q20PLVQ5
 POLAR RETRO	4 m†	2 m 4-pin Euro Pigtail QD	Q20NLP Q20NLPQ5	Q20PLP Q20PLPQ5

For more specifications see page 73.

Connection options: A model with a QD requires a mating cordset (see page 72).

For 9 m cable, add suffix W/30 to the 2 m model number (example, Q20E W/30).

QD models:

- For a 4-pin 150 mm Pico-style pigtail QD, add suffix Q (example, Q20NDQ).
- For a 4-pin integral Pico-style QD, add suffix Q7 (example, Q20EQ7).

* Available with health or alarm mode output; contact factory at 1-888-373-6767 for details.

† Retroreflective range is specified using one model BRT-84 retroreflector. Actual sensing range may differ, depending on the efficiency and reflective area of the retroreflector used. See Accessories section for more information.

Diffuse Q20

 Infrared LED  Visible Red LED

Sensing Mode	Range	Connection	Models NPN*	Models PNP*
 DIFFUSE	250 mm	2 m 4-pin Euro Pigtail QD	Q20ND Q20NDQ5	Q20PD Q20PDQ5
 DIFFUSE	800 mm	2 m 4-pin Euro Pigtail QD	Q20NDL Q20NDLQ5	Q20PDL Q20PDLQ5
 DIFFUSE	1500 mm	2 m 4-pin Euro Pigtail QD	Q20NDXL Q20NDXLQ5	Q20PDXL Q20PDXLQ5

Fixed-Field Q20

 Visible Red LED

Sensing Mode	Range	Connection	Models NPN*	Models PNP*
 FIXED-FIELD	0-50 mm Cutoff	2 m 4-pin Euro Pigtail QD	Q20NFF50 Q20NFF50Q5	Q20PFF50 Q20PFF50Q5
 FIXED-FIELD	0-100 mm Cutoff	2 m 4-pin Euro Pigtail QD	Q20NFF100 Q20NFF100Q5	Q20PFF100 Q20PFF100Q5
 FIXED-FIELD	0-150 mm Cutoff	2 m 4-pin Euro Pigtail QD	Q20NFF150 Q20NFF150Q5	Q20PFF150 Q20PFF150Q5

For more specifications see page 73.

 **Connection options:** A model with a QD requires a mating cordset (see page 72).

For 9 m cable, add suffix W/30 to the 2 m model number (example, Q20ND W/30).

QD models:

- For a 4-pin 150 mm Euro-style pigtail QD, add suffix Q5 (example, Q20NDQ5).
- For a 4-pin 150 mm Pico-style pigtail QD, add suffix Q (example, Q20NDQ).
- For a 4-pin integral Pico-style QD, add suffix Q7 (example, Q20NDQ7).

* Available with health or alarm mode output; contact factory at 1-888-373-6767 for details.



Euro QD (for Q5 models)
Straight connector models listed; for right-angle, add **RA** to the end of the model number (example, **MQDC-406RA**)

4-Pin
MQDC-406
2 m (6')
MQDC-415
5 m (15')
MQDC-430
9 m (30')



Pico QD (for Q models)
Straight connector models listed; for right-angle, **W** replaces **G** in the model number. (example, **PKG4M-2**)

4-Pin
PKG4M-2
2 m (6')
PKG4M-5
5 m (15')
PKG4M-9
9 m (30')



Pico QD (for Q7 models)
Straight snap-on connector model

Pico QD (for Q7 models)
Right-angle snap-on connector model

4-Pin
PKG4-2
2 m (6')
PKW4Z-2
2 m (6')

Additional cordset information is available
See page 758



SMBQ20H



SMBQ20LV



SMBQ20L



SMBQ20U

Additional bracket information is available
See page 722

Reflectors



Additional information is available
See page 790

Apertures



Additional information is available
See page 816



Opposed, Retroreflective,
Fixed-Field and Diffuse Models
Suffix E, EL, R, RL, LP, LV,
D, DL, DXL and FF







Q20 Specifications

Supply Voltage and Current	Fixed-field: 10 to 30 V dc (10% maximum ripple) at less than 25 mA, exclusive of load All others: 10 to 30 V dc (10% maximum ripple) at less than 18 mA, exclusive of load
Supply Protection Circuitry	Protected against reverse polarity and transient voltages
Output Configuration	Solid-state complementary; PNP (sourcing) or NPN (sinking), depending on model
Output Rating	100 mA with short circuit protection OFF-state leakage current: NPN: less than 200 µA sinking PNP: less than 10 µA sourcing ON-state saturation voltage: NPN: less than 1.6 V @ 100 mA PNP: less than 3.0 V @ 100 mA
Output Response Time	Opposed: 1 ms ON/600 ms OFF Fixed-field: 3 ms ON/1.5 ms OFF All others: 800 ms ON/OFF
Delay at Power-up	100 milliseconds; outputs do not conduct during this time
Repeatability	Opposed: 140 microseconds Fixed-field: 182 microseconds All others: 155 microseconds
Adjustments	Diffuse, Retroreflective and Polarized Retroreflective: single-turn sensitivity (Gain) adjustment potentiometer
Indicators	Emitters: Green power ON only All others: Two LED Indicators: Green: Power ON Yellow: Black (LO) wire conducting
Construction	Housing: ABS Lenses: PMMA Gain Adjuster(retro and diffuse models only): PBT
Connections	2 m or 9 m 4-wire PVC cable, 4-pin 150 mm pigtail Pico-style QD (Q), or 4-pin 150 mm pigtail Euro-style QD (Q5), or 4-pin integral Pico-style QD (Q7), depending on model. QD cordsets are ordered separately. See page 72.
Operating Conditions	Temperature: -20° to +60° C Relative humidity: 95% @ 50° C (non-condensing)
Environmental Rating	IEC IP67; NEMA 6
Vibration and Mechanical Shock	All models meet Mil. Std. 202F requirements method 201A (vibration: 10 to 60 Hz max., double amplitude 0.06", maximum acceleration 10G). Also meets IEC 947-5-2: 30G 11 ms duration, half sine wave
Application Note	1. Opposed mode sensor spacing can be reduced by alternating emitters and receivers or by applying crosstalk filters (visible red models only). 2. NPN OFF-state leakage current is < 200 µA for load resistances > 3 kΩ or optically isolated loads. For load currents of 100 mA, leakage is < 1% of load current.
Certification	



Rectangle

Rectangular sensors have a large rugged housing. The rectangle housing style offers side and barrel mounting options.

Series	Description	Max Sensing Range	Dimensions H x W x D	Protection Rating	Housing Material	Power Supply
	MINI-BEAM® Comprehensive sensor line with a series of LED colors, gain pots/TEACH modes and ac/dc models. Page 76	Opposed: 30 m Clear Plastic: 300 mm Retro: 5 m Retro Polarized: 3 m Convergent: 43 mm Diffuse: 380 mm Glass/Plastic Fiber: Varies	Varies by model	IP67	Thermoplastic Polyester	10 to 30 V dc 24 to 240 V ac 5 to 15 V dc
	Q25 Completely epoxy-encapsulated for use in harsh sensing environments, including food and beverage applications. Page 78	Opposed: 20 m Retro Polarized: 2 m Fixed-Field: 100 mm	50.2 x 25 x 30 mm	IP67 NEMA 6	Thermoplastic Polyester	10 to 30 V dc 20 to 240 V ac
	Q40 Completely epoxy-encapsulated long-range sensor available in ac or dc supply voltages. Page 80	Opposed: 60 m Retro Polarized: 6 m Fixed-Field: 600 mm	69.8 x 41 x 46 mm	QD models: IP69K Other models: IP67 NEMA 6P	Thermoplastic Polyester	10 to 30 V dc 20 to 245 V ac
	Q45 Advanced one-piece, rugged sensor with outstanding optical performance. page 84	Opposed: 60 m Retro: 9 m Polarized Retro: 6 m Laser Polarized Retro: 40 m Diffuse: 3 m Convergent: 100 m	87.6 x 44.5 x 54.1 mm	IP67 NEMA 6P	Thermoplastic Polyester	10 to 30 V dc 90 to 250 V ac 24 to 250 V ac 12 to 250 V dc
	Q60 Laser or LED sensor for low reflectivity targets, regardless of background. page 88	Adjustable-Field: 2 m Laser Adjustable-Field: 2 m	75 x 25 x 60 mm	IP67 NEMA 6	ABS	10 to 30 V dc 12 to 250 V dc 24 to 250 V ac
	PicoDot® The PicoDot® is a convergent-mode laser sensor with extreme precision. Page 92	Laser Polarized Retro: 10.6 m Laser Convergent: 305 mm	PD45: 40.6 x 45.6 x 12.7 mm PD49: 42.7 x 49.1 x 15.2 mm	PD45: IP54 PD49: IP67	ABS	10 to 30 V dc
	QM42 & QMT42 Universal housing design with 18 mm threaded lens; an ideal replacement for hundreds of other sensor styles. Page 94	QM42 Opposed: 10 m Retro Polarized: 3 m Diffuse: 400 mm Adjustable-Field: 150 mm Plastic Fiber: Varies QMT42 Diffuse: 6 m Fixed-Field: 2 m Adjustable-Field: 400 mm	QM42: 42 x 12.7 x 42 mm QMT42: 58 x 18 x 42 mm	IP67 NEMA 6	Die-cast Zinc Alloy	10 to 30 V dc

MINI-BEAM® Series

Complete Line of Industry Standard Sensors



- AC, DC or universal models available
- Infrared or visible red, green, blue or white sensing beam
- Industry standard mounting holes
- Easy push-button TEACH-mode setup available



Euro-Style
Straight connector models listed;
for right-angle, add **RA** to the end
of the model number
(example, **MQDC-406RA**)

4-Pin	5-Pin
MQDC-406 2 m (6.5')	MQDC1-506 2 m (6.5')
MQDC-415 5 m (15')	MQDC1-515 5 m (15')
MQDC-430 9 m (30')	MQDC1-530 9 m (30')



Micro-Style
Straight connector models listed;
for right-angle, add **RA** to the end
of the model number
(example, **MQDC-306RA**)

3-Pin
MQDC-306 2 m (6.5')
MQDC-315 5 m (15')
MQDC-330 9 m (30')



NAMUR Euro-Style
Straight connector models listed;
for right-angle, add **RA** to the end
of the model number
(example, **MQD9-406RA**)

4-Pin
MQD9-406 2 m (6.5')
MQD9-415 5 m (15')

Additional cordset information is available
See page 758



SMB18A



SMB18FA..



SMB18SF



SMB312B



SMB3018SC

Additional bracket information is available
See page 722

Reflectors



Additional information is available
See page 790

Apertures



Additional information is available
See page 816

MINI-BEAM® Specifications

Visit Bannerengineering.com for more information on this and other products

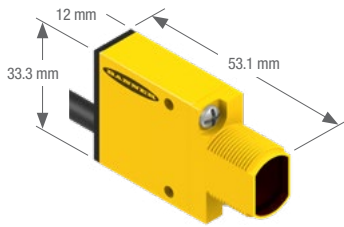

MINI-BEAM DC
Opposed, Retroreflective,
Diffuse and Convergent Models
Suffix E, R, EPD, RPD, D, LV, LP, C, C2,
CV, CV2, CVB, CV2B, CVG and CV2G



MINI-BEAM DC
Diffuse Models
Suffix DBZ and W



MINI-BEAM DC
Glass Fiber Models
Suffix F, FV, FVG and FVB



MINI-BEAM DC
Plastic Fiber Models
Suffix FP, FPG and FPB

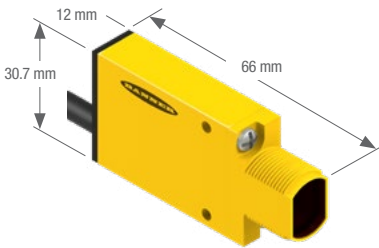

MINI-BEAM AC & Expert
Opposed, Retroreflective,
Diffuse and Convergent Models
Suffix E, R, EPD, RPD, D, DV, LV, LP, C,
CV, CV2, CVG, CVB and CVW

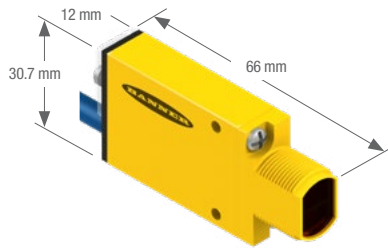

MINI-BEAM NAMUR
Retroreflective, Diffuse, Opposed and
Convergent Models
Suffix E, R, LV, D and CV



MINI-BEAM AC, Expert & NAMUR
Diffuse Models
Suffix DBZ and W

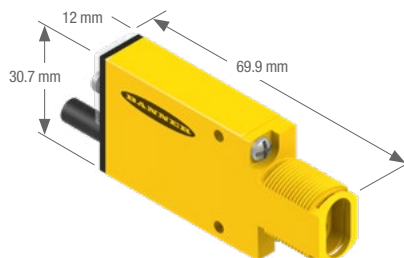

MINI-BEAM AC, Expert & NAMUR
Glass Fiber Models
Suffix F and FV



MINI-BEAM AC, Expert &
Plastic Fiber Models
Suffix FP

Q25 Series

Right-Angle Base-Mount Rectangular Sensors



- Completely epoxy-encapsulated for use in harsh sensing environments
- Available in opposed, retroreflective and fixed-field modes
- Available in 10-30 V dc or 20-250 V ac
- Wide operating range from -40° to +70° C
- Models rated to IP67 and IP69K to withstand harsh washdown environments



Euro-Style
Straight connector models listed; for right-angle, add **RA** to the end of the model number (example, **MQDC-406RA**)

MQDC-406
2 m (6.5')
MQDC-415
5 m (15')
MQDC-430
9 m (30')



Micro-Style
Straight connector models listed; for right-angle, add **RA** to the end of the model number (example, **MQDC-306RA**)

MQAC-406
2 m (6.5')
MQAC-415
5 m (15')
MQAC-430
9 m (30')

*Additional cordset information is available
See page 758*



SMB18A



SMB18FA..



SMB18SF

*Additional bracket information is available
See page 722*



Q25 Opposed, Retroreflective and Fixed-Field Models
Suffix E, R, LP, and FF

Q25 DC Specifications

Supply Voltage and Current	10 to 30 V dc (10% max. ripple); Supply current (exclusive of load current): Opposed Emitters: 25 mA Opposed Receivers: 20 mA Polarized Retroreflective: 30 mA Fixed-Field: 35 mA
Output Configuration	Solid-state complementary dc switch; NPN (current sinking) or PNP (current sourcing), depending on model. The Dark Operate (DO) output may be wired as a normally open marginal signal alarm output, depending upon hookup to the power supply.
Output Rating	150 mA max. (each) in standard hookup. When wired for alarm output, the total load may not exceed 150 mA OFF-state leakage current: less than 1 μ A at 30 V dc ON-state saturation voltage: less than 1 V at 10 mA dc; less than 1.5 V at 150 mA dc
Output Response Time	Opposed: 3 milliseconds ON, 1.5 milliseconds OFF Polarized Retroreflective and Fixed-Field: 3 milliseconds ON/OFF
Delay at Power-up	100 milliseconds; outputs do not conduct during this time
Repeatability	Opposed: 375 microseconds Polarized Retroreflective and Fixed-Field: 750 microseconds Repeatability and response are independent of signal strength
Indicators	Two LEDs: Green and Yellow Green: Power ON Green Flashing: output overload Yellow: Light Operate (LO) output energized Yellow Flashing: marginal gain
Construction	Housings are thermoplastic polyester. Lenses are polycarbonate or acrylic; one jam nut included.
Environmental Rating	Leakproof design rated NEMA 6P, IP67. QD models rated IP69K per DIN 40050-9.
Operating Conditions	Temperature: -40° to +70° C Relative humidity: 90% at 50° C (non-condensing)
Vibration and Mechanical Shock	All models meet Mil. Std. 202F requirements. Method 201A (Vibration; frequency 10 to 60 Hz, max., double amplitude 0.06-inch acceleration 10G). Method 213B conditions H&I (Shock: 75G with unit operating; 100G for non-operation)
Certifications	 ECOLAB® chemical compatibility pending on some models; contact Banner Engineering for details

Q25 AC Specifications

Supply Voltage and Current	20 to 250 V ac (50/60 Hz) Average current: 20 mA Peak current: 200 mA at 20 V ac, 500 mA at 120 V ac, 750 mA at 250 V ac
Output Configuration	Solid-state ac switch; three-wire hookup; Choose Light Operate (LO) or Dark Operate (DO), depending on model Light Operate: Output conducts when the sensor sees its own (or the emitter's) modulated light Dark Operate: Output conducts when sensor sees dark
Output Rating	300 mA max. (continuous) Fixed-Field: derate 5 mA/° C above +50° C Inrush capability: 1 amp for 20 milliseconds, non-repetitive OFF-state leakage current: less than 100 μ A ON-state voltage drop: 3 V at 300 mA ac; 2 V at 15 mA ac
Output Response Time	Opposed: 16 milliseconds ON, 8 milliseconds OFF Polarized Retroreflective and Fixed-Field: 16 milliseconds ON/OFF
Delay at Power-up	100 milliseconds
Repeatability	Opposed: 2 milliseconds; Polarized Retroreflective and Fixed-Field: 4 milliseconds Repeatability and response are independent of signal strength.
Indicators	Two LEDs: Green and Yellow Solid Green: Power ON Solid Yellow: Light sensed Yellow Flashing: marginal gain
Construction	Housings are thermoplastic polyester. Lenses are polycarbonate or acrylic; one jam nut included.
Environmental Rating	Leakproof design rated NEMA 6P, IP67. QD models rated IP69K per DIN 40050-9.
Operating Conditions	Temperature: -40° to +70° C Relative humidity: 90% at 50° C (non-condensing)
Vibration and Mechanical Shock	All models meet Mil. Std. 202F requirements. Method 201A (Vibration; frequency 10 to 60 Hz, max., double amplitude 0.06-inch acceleration 10G). Method 213B conditions H&I (Shock: 75G with unit operating; 100G for non-operation)
Certifications	

Q40 Series

Long-Range Sensors



- Reliable sensing without adjustments
- Completely epoxy-encapsulated for superior durability
- Long-range sensing in harsh environments
- Available in 10-30 V dc or 20-250 V ac
- Available in opposed, retroreflective and fixed-field modes
- Cordsets and brackets see page 82

Opposed Q40, 10-30 V DC

Infrared LED

Sensing Mode	Range	Connection	Models NPN	Models PNP
 OPPOSED	60 m	2 m 4-Pin Euro QD	Q406E Emitter Q406EQ Emitter	
	60 m	2 m 4-Pin Euro QD	Q40SN6R Q40SN6RQ	Q40SP6R Q40SP6RQ

Polar Retro Q40, 10-30 V DC

Visible Red LED

Sensing Mode	Range	Connection	Models NPN	Models PNP
 POLAR RETRO	6 m†	2 m	Q40SN6LP	Q40SP6LP
	6 m	4-Pin Euro QD	Q40SN6LPQ	Q40SP6LPQ

Fixed-Field Q40, 10-30 V DC

Infrared LED

Sensing Mode	Range	Connection	Models NPN	Models PNP
 FIXED-FIELD	0 - 200 mm Cutoff	2 m 4-Pin Euro QD	Q40SN6FF200 Q40SN6FF200Q	Q40SP6FF200 Q40SP6FF200Q
	0 - 400 mm Cutoff	2 m 4-Pin Euro QD	Q40SN6FF400 Q40SN6FF400Q	Q40SP6FF400 Q40SP6FF400Q
	0 - 600 mm Cutoff	2 m 4-Pin Euro QD	Q40SN6FF600 Q40SN6FF600Q	Q40SP6FF600 Q40SP6FF600Q
	0 - 200 mm Cutoff	2 m 4-Pin Euro QD	Q40SN6FF200 Q40SN6FF200Q	Q40SP6FF200 Q40SP6FF200Q
	0 - 400 mm Cutoff	2 m 4-Pin Euro QD	Q40SN6FF400 Q40SN6FF400Q	Q40SP6FF400 Q40SP6FF400Q
	0 - 600 mm Cutoff	2 m 4-Pin Euro QD	Q40SN6FF600 Q40SN6FF600Q	Q40SP6FF600 Q40SP6FF600Q

For more specifications see page 82.

Connection options: A model with a QD requires a mating cordset (see page 82).

For 9 m cable, add suffix W/30 to the 2 m model number (example, Q40SN6R W/30).

† Retroreflective range is specified using a BRT-3 retroreflector.

Actual sensing range may differ, depending on the efficiency and reflective area of the retroreflector used. See Accessories for more information.

Opposed Q40, 20-250 V AC

 Infrared LED

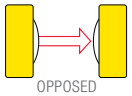
Sensing Mode	Range	Connection	Models LO	Models DO
 OPPOSED	60 m	2 m	Q403E Emitter	
		4-Pin Micro QD	Q403EQ1 Emitter	
	60 m	2 m	Q40AW3R	Q40RW3R
		4-Pin Micro QD	Q40AW3RQ1	Q40RW3RQ1

Polar Retro Q40, 20-250 V AC

 Visible Red LED

Sensing Mode	Range	Connection	Models LO	Models DO
 POLAR RETRO	6 m [†]	2 m	Q40AW3LP	Q40RW3LP
		4-Pin Micro QD	Q40AW3LPQ1	Q40RW3LPQ1

Fixed-Field Q40, 20-250 V AC

 Infrared LED

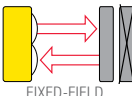
Sensing Mode	Range	Connection	Models LO	Models DO
 FIXED-FIELD	0 - 200 mm Cutoff	2 m	Q40AW3FF200	Q40RW3FF200
		4-Pin Micro QD	Q40AW3FF200Q1	Q40RW3FF200Q1
	0 - 400 mm Cutoff	2 m	Q40AW3FF400	Q40RW3FF400
		4-Pin Micro QD	Q40AW3FF400Q1	Q40RW3FF400Q1
	0 - 600 mm Cutoff	2 m	Q40AW3FF600	Q40RW3FF600
		4-Pin Micro QD	Q40AW3FF600Q1	Q40RW3FF600Q1

For more specifications see page 82.

 Connection options: A model with a QD requires a mating cordset (see page 82).

For 9 m cable, add suffix W/30 to the 2 m model number (example, Q40SN6R W/30).

[†] Retroreflective range is specified using a BRT-3 retroreflector.
Actual sensing range may differ, depending on the efficiency and reflective area of the retroreflector used. See Accessories for more information.



4-Pin

Euro-Style
Straight connector models listed; for right-angle, add **RA** to the end of the model number (example, **MQDC-406RA**)

MQDC-406
2 m (6.5')
MQDC-415
5 m (15')
MQDC-430
9 m (30')



4-Pin

Micro-Style
Straight connector models listed; for right-angle, add **RA** to the end of the model number (example, **MQDC-306RA**)

MQAC-406
2 m (6.5')
MQAC-415
5 m (15')
MQAC-430
9 m (30')

Additional cordset information is available
See page 758



SMB30A



SMB30FA..

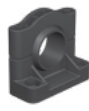

SMB30SC



SMBAMS30P

Additional bracket information is available
See page 722

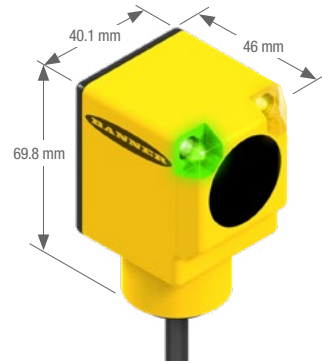

Opposed,
Polarized Retroreflective
and Fixed-Field Models
Suffix E, R, LP and FF

Reflectors



Apertures



Additional information is available
See page 790

Additional information is available
See page 816

Q40 DC Specifications



Supply Voltage and Current	10 to 30 V dc (10% max. ripple); Supply current (exclusive of load current): Opposed Emitters: 25 mA Opposed Receivers: 20 mA Polarized Retroreflective: 30 mA Fixed-Field: 35 mA
Supply Protection Circuitry	Protected against reverse polarity and transient voltages
Output Configuration	Solid-state complementary; choose NPN (current sinking) or PNP (current sourcing) models The Dark Operate (DO) output may be wired as a normally open marginal signal alarm output, depending upon hookup to the power supply
Output Rating	150 mA max. (each) in standard hookup; When wired for alarm output, the total load may not exceed 150 mA OFF-state leakage current: less than 1 µA at 30 V dc ON-state saturation voltage: less than 1 V at 10 mA dc; less than 1.5 V at 150 mA dc
Output Protection Circuitry	Protected against false pulse on power-up and continuous overload or short circuit of outputs
Output Response Time	Opposed: 3 milliseconds ON; 1.5 milliseconds OFF Polarized Retroreflective and Fixed-Field: 3 milliseconds ON/OFF
Delay at Power-up	100 milliseconds; outputs are non-conducting during this time
Repeatability	Opposed: 375 microseconds Polarized Retroreflective and Fixed-Field: 750 microseconds Repeatability and response are independent of signal strength
Indicators	Two LEDs: Green and Yellow Solid Green: Power ON Solid Yellow: Light Operate (LO) output energized See datasheet for detailed information Flashing Green: Output over loaded Flashing Yellow: Marginal excess gain
Construction	Housings are thermoplastic polyester. Lenses are polycarbonate or acrylic; one jam nut included.
Environmental Rating	Leakproof design rated NEMA 6P, IP67. QD models rated IP69K per DIN 40050-9.
Connections	2 m or 9 m attached cable, or 4-pin Euro-style quick-disconnect fitting. QD cordsets are ordered separately. See page 82.
Operating Conditions	Temperature: -40° to +70° C Relative humidity: 90% at 50° C (non-condensing)
Vibration and Mechanical Shock	All models meet Mil. Std. 202F requirements. Method 201A (Vibration; frequency 10 to 60 Hz, max., double amplitude 0.06-inch acceleration 10G). Method 213B conditions H&I (Shock: 75G with unit operating; 100G for non-operation)

Certifications



ECOLAB® chemical compatibility pending on some models; contact Banner Engineering for details

Q40 AC Specifications

Supply Voltage and Current	20 to 250 V ac (50/60 Hz) Average current: 20 mA Peak current: 200 mA at 20 V ac, 500 mA at 120 V ac, 750 mA at 250 V ac
Supply Protection Circuitry	Protected against transient voltages
Output Configuration	Solid-state ac switch; three-wire hookup; choose Light Operate (LO) or Dark Operate (DO) models Light Operate: Output conducts when the sensor sees its own (or the emitter's) modulated light Dark Operate: Output conducts when sensor sees dark
Output Rating	300 mA max. (continuous) Fixed-Field: derate 5 mA/° C above +50° C Inrush capability: 1 amp for 20 milliseconds, non-repetitive OFF-state leakage current: less than 100 µA ON-state voltage drop: 3 V at 300 mA ac; 2 V at 15 mA ac
Output Protection Circuitry	Protected against false pulse on power-up
Output Response Time	Opposed: 16 milliseconds ON; 8 milliseconds OFF Polarized Retroreflective and Fixed-Field: 16 milliseconds ON/OFF
Delay at Power-up	100 milliseconds
Repeatability	Opposed: 2 milliseconds Polarized Retroreflective and Fixed-Field: 4 milliseconds Repeatability and response are independent of signal strength
Indicators	Two LEDs: Green and Yellow Solid Green: Power ON Solid Yellow: Light sensed Flashing Yellow: marginal excess gain See datasheet for detailed information
Construction	Housings are thermoplastic polyester. Lenses are polycarbonate or acrylic; one jam nut included.
Environmental Rating	Leakproof design rated NEMA 6P, IP67. QD models rated IP69K per DIN 40050-9.
Connections	2 m or 9 m attached cable, or 4-pin Micro-style quick-disconnect fitting. QD cordsets are ordered separately. See page 82.
Operating Conditions	Temperature: -40° to +70° C Relative humidity: 90% at 50° C (non-condensing)
Vibration and Mechanical Shock	All models meet Mil. Std. 202F requirements. Method 201A (Vibration; frequency 10 to 60 Hz, max, double amplitude 0.06-inch acceleration 10G). Method 213B conditions H&I (Shock: 75G with unit operating; 100G for non-operation)
Certifications	   ECOLAB® chemical compatibility pending on some models; contact Banner Engineering for details

Q45 Series

Adjustable Output Timing Logic



- The Q45 Standard sensor is available in multiple sensing modes to suit many application needs.
- Opposed, retroreflective, diffuse, convergent, laser and glass and plastic fiber optic modes
- Electromechanical or solid-state options
- Rugged design rated to IP67 to withstand 1200 psi washdown

Euro-Style
Straight connector models listed;
for right-angle, add **RA** to the end
of the model number
(example, **MQDC-406RA**)



4-Pin	5-Pin
MQDC-406 2 m (6.5')	MQDC1-506 2 m (6.5')
MQDC-415 5 m (15')	MQDC1-515 5 m (15')
MQDC-430 9 m (30')	MQDC1-530 9 m (30')

Micro-Style
Straight connector models listed;
for right-angle, add **RA** to the end
of the model number
(example, **MQAC-406RA**)



4-Pin
MQAC-406 2 m (6.5')
MQAC-415 5 m (15')
MQAC-430 9 m (30')

Mini-Style
Straight connector models only



3-Pin	4-Pin	5-Pin
MBCC-306 2 m (6.5')	MBCC-406 2 m (6.5')	MBCC-506 2 m (6.5')
MBCC-315 5 m (15')	MBCC-415 5 m (15')	MBCC-515 5 m (15')
MBCC-330 9 m (30')	MBCC-430 9 m (30')	MBCC-530 9 m (30')

NAMUR Euro-Style
Straight connector models listed;
for right-angle, add **RA** to the end
of the model number
(example, **MQD9-406RA**)



4-Pin
MQD9-406 2 m (6.5')
MQD9-415 5 m (15')

*Additional cordset information is available
See page 758*



SMB30A



SMB30FA..

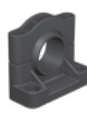

SMB30SC

*Additional bracket information is available
See page 722*

Reflectors



*Additional information is available
See page 790*

Apertures



*Additional information is available
See page 816*

Q45 Specifications

Visit Bannerengineering.com for more information on this and other products



Opposed, Retroreflective and Diffuse Models
Suffix E, R, D, DL, DX, LV and LP



Convergent Models
Suffix CV and CV4



Retroreflective Laser Models
Suffix LL and LLP

OTHER AVAILABLE MODELS



Wireless Q45 page 512



Plastic Fiber Q45 see website



Glass Fiber Q45 see website

Q45 Wireless

Self-Contained Wireless Solution



- Improve efficiency by monitoring and coordinating multiple machines and processes without pulling cables
- 1 km line-of-sight
- Built-in antenna
- 2.4 GHz unlicensed frequency
- Used exclusively with Banner's DX80 Gateway (see page 512)

Retroflective Q45 Wireless

➔ Visible Red LED

Sensing Mode	Sensing Range	Wireless Communication Range	Output	Models
 <p>POLAR RETRO</p>	6 m	1,000 m (with line of sight)	Discrete output via Gateway	DX80N2Q45LP

Diffuse Q45 Wireless

➔ Visible Red LED

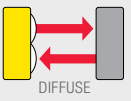
Sensing Mode	Sensing Range	Wireless Communication Range	Output	Models
 <p>DIFFUSE</p>	300 mm	1,000 m (with line of sight)	Discrete output via Gateway	DX80N2Q45D

Convergent Q45 Wireless

➔ Visible Red LED

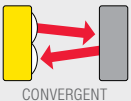
Sensing Mode	Sensing Range	Wireless Communication Range	Output	Models
 <p>CONVERGENT</p>	38 mm	1,000 m (with line of sight)	Discrete output via Gateway	DX80N2Q45CV

Fiber Optic Q45 Wireless

➔ Visible Red LED

Sensing Mode	Sensing Range	Wireless Communication Range	Output	Models
 <p>GLASS FIBER</p>	varies by selected fiber	1,000 m (with line of sight)	Discrete output via gateway	DX80N2Q45F

Q45 Wireless Specifications

Visit Bannerengineering.com for more information on this and other products



Opposed, Retroreflective and Diffuse Models
Suffix E, R, D, DL, DX, LV and LP

OTHER AVAILABLE MODELS



Q45 page 84



Plastic Fiber Q45 see website



Glass Fiber Q45 see website

Q60 Series

Long-Range, Adjustable-Field Sensors



- Detects objects with a defined sensing field, ignoring objects located beyond the sensing point
- Output timing ON/OFF
- Available in 10-30 V dc, 12-250 V dc or 24-250 V ac
- Features two-turn, logarithmic adjustment of sensing field cutoff point from 0.2 to 2 m
- Easy push-button or remote programming of output timing
- Cordsets and brackets see page 90

Adjustable-Field Q60, 10-30 V DC

 Infrared LED

 Visible Red LED

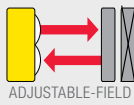
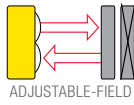
Sensing Mode	Range	Connection	Output Type	Models
 ADJUSTABLE-FIELD	Min.: 65 - 130 mm [†] Cutoff: 200 - 1000 mm	2 m	Bipolar NPN/PNP	Q60BB6AFV1000
		5-Pin Euro QD		Q60BB6AFV1000Q
 ADJUSTABLE-FIELD	Min.: 50 - 125 mm [†] Cutoff: 200 - 2000 mm	2 m	Bipolar NPN/PNP	Q60BB6AF2000
		5-Pin Euro QD		Q60BB6AF2000Q

Laser Adjustable-Field Q60, 10-30 V DC

 Visible Red Laser

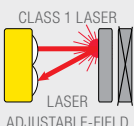
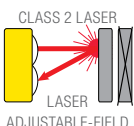
Sensing Mode	Range	Connection	Output Type	Models
 CLASS 1 LASER LASER ADJUSTABLE-FIELD	Min.: 100 - 260 mm [†] Cutoff: 200 - 1400 mm	2 m	Bipolar NPN/PNP	Q60BB6LAF1400
		5-Pin Euro QD		Q60BB6LAF1400Q
 CLASS 2 LASER LASER ADJUSTABLE-FIELD	Min.: 75 - 240 mm [†] Cutoff: 200 - 2000 mm	2 m	Bipolar NPN/PNP	Q60BB6LAF2000
		5-Pin Euro QD		Q60BB6LAF2000Q

For more specifications see page 91.

 Connection options: A model with a QD requires a mating cordset (see page 90).
 For 9 m cable, add suffix W/30 to the 2 m model number (example, Q60BB6AF2000 W/30).
[†] Minimum range varies by established cutoff point (see excess gain curves, page 142 and cutoff point deviation curves, page 143).

Adjustable-Field Q60, 12-250 V DC or 24-250 V AC

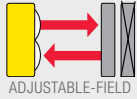
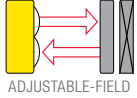

Sensing Mode	Range	Connection	Output Type	Models
 ADJUSTABLE-FIELD	Min.: 65 - 130 mm [†] Cutoff: 200 - 1000 mm	2 m	SPDT e/m Relay	Q60VR3AFV1000
		4-Pin Micro QD	SPDT e/m Relay	Q60VR3AFV1000Q1
 ADJUSTABLE-FIELD	Min.: 50 - 125 mm [†] Cutoff: 200 - 2000 mm	2 m	SPDT e/m Relay	Q60VR3AF2000
		4-Pin Micro QD	SPDT e/m Relay	Q60VR3AF2000Q1

Laser Adjustable-Field Q60, 12-250 V DC or 24-250 V AC

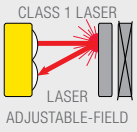
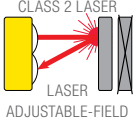

Sensing Mode	Range	Connection	Output Type	Models
 ADJUSTABLE-FIELD	Min.: 100 - 260 mm [†] Cutoff: 200 - 1400 mm	2 m	SPDT e/m Relay	Q60VR3LAF1400
		4-Pin Micro QD	SPDT e/m Relay	Q60VR3LAF1400Q1
 ADJUSTABLE-FIELD	Min.: 75 - 240 mm [†] Cutoff: 200 - 2000 mm	2 m	SPDT e/m Relay	Q60VR3LAF2000
		4-Pin Micro QD	SPDT e/m Relay	Q60VR3LAF2000Q1

For more specifications see page 91.

 Connection options: A model with a QD requires a mating cordset (see page 90).
 For 9 m cable, add suffix W/30 to the 2 m model number (example, Q60VR3AFV1000 W/30).
[†] Minimum range varies by established cutoff point (see excess gain curves, page 142 and cutoff point deviation curves, page 143).



5-Pin
MQDC1-506
 2 m (6.5')
MQDC1-515
 5 m (15')
MQDC1-530
 9 m (30')

Euro-Style
 Straight connector models listed;
 for right-angle, add **RA** to the end
 of the model number (example,
MQDC1-506RA)



4-Pin
MQAC-406
 2 m (6.5')
MQAC-415
 5 m (15')
MQAC-430
 9 m (30')

Micro-Style
 Straight connector models listed;
 for right-angle, add **RA** to the end
 of the model number (example,
MQAC-406RA)

Additional cordset information is available
 See page page 758



Adjustable-Field Models
 Suffix AF, AFV and LAF



SMBAMSQ60IP



SMBAMSQ60P

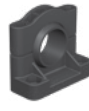

SMBQ60

Additional bracket information is available
 See page page 722



Class 1 Lasers

Lasers that are safe under reasonably foreseeable conditions of operation, including the use of optical instruments for intrabeam viewing. Reference 60825-1 Amend. 2 © IEC:2001(E), section 8.2.

For safe laser use:

- Do not permit a person to stare at the laser from within the beam
- Do not point the laser at a person's eye at close range
- Locate open laser beam paths either above or below eye level, where practical

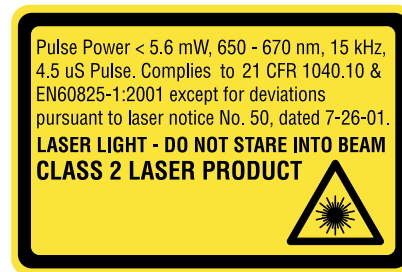



Class 2 Lasers

Lasers that emit visible radiation in the wavelength range from 400 nm to 700 nm where eye protection is normally afforded by aversion responses, including the blink reflex. This reaction may be expected to provide adequate protection under reasonably foreseeable conditions of operation, including the use of optical instruments for intrabeam viewing. Reference 60825-1 Amend. 2 © IEC:2001(E), section 8.2.

For safe laser use:

- Do not permit a person to stare at the laser from within the beam
- Do not point the laser at a person's eye at close range
- Locate open laser beam paths either above or below eye level, where practical

Q60 Specifications

Supply Voltage and Current	Q60BB6AF and Q60BB6AFV models: 10 to 30 V dc (10% max. ripple) at less than 50 mA exclusive of load Q60BB6LAF models: 10 to 30 V dc (10% max. ripple) at less than 35 mA exclusive of load Q60VR3LAF and Q60VR3AFV Universal models: 12 to 250 V dc or 24 to 250 V ac, 50/60 Hz Input power 1.5 W max.	
Supply Protection Circuitry	Protected against reverse polarity and transient voltages (Q60VR3 model's dc hookup is without regard to polarity)	
Output Configuration	Q60BB6AF, Q60BB6AFV and Q60BB6LAF models: Bipolar: one NPN (current sinking) and one PNP (current sourcing) open-collector transistor Q60VR3AF, Q60VR3LAF and Q60VR3AFV cabled models: E/M Relay (SPDT), normally closed and normally open contacts Q60VR3AFQ1, Q60VR3AFVQ1 and Q60VR3LAFQ1 (QD) models: E/M Relay (SPST), normally open contact	
Output Rating	DC models: 150 mA max. each output @ 25 °C OFF-state leakage current: less than 5 µA @ 30 V dc Output saturation NPN: less than 200 mV @ 10 mA; less than 1 V @ 150 mA Output saturation PNP: less than 1 V at 10 mA; less than 1.5 V at 150 mA Universal Voltage models: Min. voltage and current: 5 V dc, 10 mA Mechanical life of relay: 50,000,000 operations Electrical life of relay at full resistive load: 100,000 operations Max. switching power (resistive load): Cabled models: 1250 VA, 150 W QD models: 750 VA, 90 W Max. switching voltage (resistive load): Cabled models: 250 V ac, 125 V dc QD models: 250 V ac, 125 V dc Max. switching current (resistive load): Cabled models: 5 A @ 250 V ac, 5 A @ 30 V dc derated to 200 mA @ 125 V dc QD models: 3 A @ 250 V ac, 3 A @ 30 V dc derated to 200 mA @ 125 V dc	
Output Protection Circuitry	Q60BB6AF, Q60BB6LAF and Q60BB6AFV models: Protected against continuous overload or short circuit of outputs All models: Protected against false pulse on power-up	
Output Response Time	Q60BB6AF, Q60BB6LAF and Q60BB6AFV models: 2 milliseconds ON/OFF Q60VR3AF, Q60VR3LAF and Q60VR3AFV Universal models: 15 milliseconds ON/OFF	
Delay at Power-up	150 milliseconds (Q60BB6LAF has 1 second max.); outputs do not conduct during this time	
Repeatability	500 microseconds	
Sensing Hysteresis	2000 mm cutoff - less than 3% of set cutoff distance 1600 mm cutoff - less than 2.25% of set cutoff distance 1200 mm cutoff - less than 1.30% of set cutoff distance	800 mm cutoff - less than 0.5% of set cutoff distance 400 mm cutoff - less than 0.25% of set cutoff distance
Adjustments	2 momentary push buttons: ON-delay and OFF-delay ON Delay select: 8 milliseconds to 16 seconds LO/DO select OFF Delay select: 8 milliseconds to 16 seconds Push-button lockout: for security Slotted, geared, 2-turn, cutoff range adjustment screw (mechanical stops on both ends of travel)	
Indicators	Q60AF, Q60AFV and Q60LAF models: ON-Delay Green ON Steady: Run mode, ON-delay is active Green Flashing: ON-delay Selection mode is active OFF-Delay Green ON Steady: Run mode, OFF-delay is active Green Flashing: OFF-delay Selection mode is active 5-Segment Light Bar*: Indicates relative delay time during ON/OFF-delay Selection modes Output Amber ON Steady: Outputs are conducting Green ON Steady: During ON/OFF-delay Selection modes Dark Operate Green ON Steady: Dark Operate is selected Lockout Green ON Steady: Buttons are locked out Light Operate Green ON Steady: Light Operate is selected Signal Green ON Steady: Sensor is receiving signal Green Flashing: Marginal signal (1.0 to 2.25 excess gain)	
NOTE: Outputs are active during on/off timing selection mode.	*Output, Dark Operate, Lockout, Light Operate and Signal indicators function as 5-Segment Light Bar during ON/OFF-delay Selection modes	
Laser Characteristics	Spot Size: approximately 4 x 2 mm throughout range (collimated beam) Angle of Divergence: 5 milliradians NOTE: Contact factory for custom laser spot size.	
Construction	Housing: ABS polycarbonate blend Lens: acrylic Cover: Clear ABS	
Environmental Rating	IEC IP67; NEMA 6	
Connections	2 m or 9 m integral cable. DC models offer a 5-pin Euro-style QD fitting. AC models offer 4-pin Micro-style QD fitting. QD cordsets are ordered separately. See page 90.	
Operating Conditions	Temperature: Q60BB6LAF (DC) models: -10° to +50° C Q60VR3LAF Universal models: -10° to +45° C All others: -20° to +55° C Relative humidity: 90% at 50° C (non-condensing)	
Certifications	 	

PicoDot®

Laser Precision Sensors



- Convergent-mode laser sensor delivers precise position detection, inspection and counting
- Powerful retroreflective models offer long-range retroreflective sensing and have a precise, narrow beam to sense small objects at close range or larger objects at 10.6 m
- Convergent models have precise 0.25 mm beam width and ignore objects beyond the maximum sensing distance
- All models have a gain sensitivity potentiometer for fine tuning sensor performance
- Models available with environmentally sealed housing

Laser Polar Retro PicoDot®, 10-30 V DC

➔ Visible Red LED

Sensing Mode	Range/Focus	Connection	Housing Rating	Models NPN	Models PNP
<p>CLASS 2 LASER POLAR RETRO</p>	0.2 m - 10.6 m†	2 m	IP54, NEMA 3	PD45VN6LLP PD45VN6LLPQ	PD45VP6LLP PD45VP6LLPQ
		5-pin Euro Pigtail QD			
	0.2 m - 10.6 m†	2 m	IP67, NEMA 6	PD49VN6LLP PD49VN6LLPQ	PD49VP6LLP PD49VP6LLPQ
		5-pin Euro Pigtail QD			

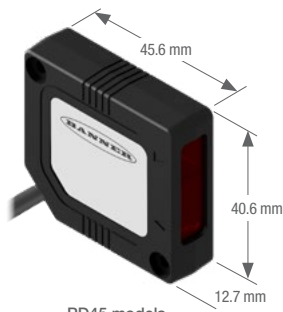

PD45 models
Laser Polarized Retroreflective
and Laser Convergent Models
Suffix LLP and C..

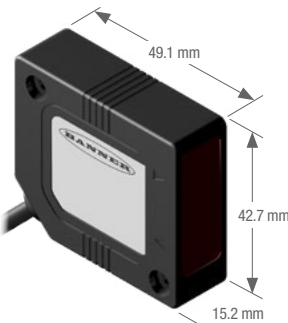

PD49 models
Laser Polarized Retroreflective
and Laser Convergent Models
Suffix LLP and C..

Laser Convergent PicoDot®, 10-30 V DC

➔ Visible Red LED

Sensing Mode	Range/Focus	Connection	Housing Rating	Models NPN	Models PNP
<p>CLASS 2 LASER CONVERGENT</p>	50 mm	2 m	IP54, NEMA 3	PD45VN6C50 PD45VN6C50Q	PD45VP6C50 PD45VP6C50Q
		5-pin Euro Pigtail QD			
		2 m	IP67, NEMA 6	PD49VN6C50 PD49VN6C50Q	PD49VP6C50 PD49VP6C50Q
		5-pin Euro Pigtail QD			
<p>CLASS 2 LASER CONVERGENT</p>	102 mm	2 m	IP54, NEMA 3	PD45VN6C100 PD45VN6C100Q	PD45VP6C100 PD45VP6C100Q
		5-pin Euro Pigtail QD			
		2 m	IP67, NEMA 6	PD49VN6C100 PD49VN6C100Q	PD49VP6C100 PD49VP6C100Q
		5-pin Euro Pigtail QD			
<p>CLASS 2 LASER CONVERGENT</p>	203 mm	2 m	IP54, NEMA 3	PD45VN6C200 PD45VN6C200Q	PD45VP6C200 PD45VP6C200Q
		5-pin Euro Pigtail QD			
		2 m	IP67, NEMA 6	PD49VN6C200 PD49VN6C200Q	PD49VP6C200 PD49VP6C200Q
		5-pin Euro Pigtail QD			
<p>CLASS 2 LASER CONVERGENT</p>	305 mm	2 m	IP54, NEMA 3	PD45VN6C300 PD45VN6C300Q	PD45VP6C300 PD45VP6C300Q
		5-pin Euro Pigtail QD			
	305 mm	2 m	IP67, NEMA 6	PD49VN6C300 PD49VN6C300Q	PD49VP6C300 PD49VP6C300Q
		5-pin Euro Pigtail QD			

➔ Connection options: A model with a QD requires a mating cordset.

For 9 m cable, add suffix W/30 to the 2 m model number (example, PD45VN6LLP W/30).

† Tested using a BRT-51X51BM retro target (included with each sensor). Actual range depends on the efficiency and size of the retroreflective target. Some targets have produced ranges up to 40 m.



Euro-Style
Straight connector models listed; for right-angle, add **RA** to the end of the model number (example, **MQDC1-506RA**)

5-Pin
MDDC-501.5
.5 m (1.6')
MQDC1-506
2 m (6.5')
MQDC1-515
5 m (15')
MQDC1-530
9 m (30')



SMB46A



SMB46S



SMB46L



SMB46U

Additional cordset information is available
See page page 758

Additional bracket information is available
See page page 723

Class 2 Laser Safety Notes

Low-power lasers are by definition incapable of causing eye injury within the duration of the blink (aversion response) of 0.25 seconds. They also must emit only visible wavelengths (400 - 700 nm). Therefore, an ocular hazard can exist only if an individual overcomes their natural aversion to bright light and stares directly into the laser beam.

For safe laser use:

- Do not permit a person to stare at the laser from within the beam
- Do not point the laser at a person's eye at close range
- The beam emitted by a Class 2 laser product should be terminated at the end of its useful path. Open laser beam paths should be located above or below eye level where practical.

LASER LIGHT
DO NOT STARE INTO BEAM
CLASS 2 LASER PRODUCT

Avoid exposure - laser light emitted from this aperture

PEAK POWER 2 mW
20KHz 10% DUTY CYCLE
660 - 680 nm
COMPLIES TO 21 CFR PART
1040.10 AND EN60825-1:1994

PicoDot® Specifications

Supply Voltage and Current	10 to 30 V dc (10% max ripple) at less than 20 mA, exclusive of load
Beam Size at Aperture	3.75 x 1.85 mm (Retroreflective Models)
Beam Divergence	Approx. 1 milliradian (Retroreflective Models)
Laser Classification	Class 2 safety (CDRH (FDA) 1040.10 and IEC 60875-1)
Supply Protection Circuitry	Protected against reverse polarity, over voltage, and transient voltages
Delay at Power-up	< 1 second
Output Configuration	Solid-state complementary; choose NPN (current sinking) or PNP (current sourcing) models
Output Rating	150 mA max. (each output) OFF-state leakage current: less than 1 µA at 30 V dc ON-state saturation voltage: less than 0.3 V at 10 mA dc; less than 0.8 V at 150 mA dc
Output Protection	Protected against continuous overload or short-circuit of outputs; Overload trip point ≥ 220 milliamps
Output Response Time	0.2 milliseconds (200 microseconds) ON/OFF
Repeatability	50 microseconds; Rep Rate 20 KHz
Spot Size at Focus	0.25 mm
Range	C50 models: 25 to 58 mm; focus at 50 mm ± 5 mm C100 models: 25 to 115 mm; focus at 102 mm ± 5 mm C200 models: 25 to 216 mm; focus at 203 mm ± 5 mm C300 models: 25 to 317 mm; focus at 305 mm ± 5 mm LLP models: 0.2 to 10.6 m, using supplied retroreflective target
Adjustments	12-turn slotted brass Gain (sensitivity) adjustment potentiometer
Extinguishing Wire	Gray wire held "low" for laser operation; "high" to turn laser OFF; Low ≤ 1.0 V dc; High ≥ Vsupply -4.0 V dc (< 30 V dc) or disconnect wire; 100 milliseconds delay upon enable
Indicators	Two LEDs: Solid Green: Power ON Flashing Green: output overloaded Solid Yellow: Light sensed; Light Operate (LO) output conducting Flashing Yellow: marginal excess gain See datasheet for detailed information
Construction	PD45: Housings are heat-resistant ABS, UL94-VO rated; acrylic lens cover PD49: Housings are sealed, heat resistant ABS/polycarbonate alloy, UL94-VO rated, acrylic lens cover
Environmental Rating	PD45: IP54; NEMA 3 PD49: IP67; NEMA 6
Connections	2 m or 9 m attached cable, or 5-pin Euro-style 150 mm pigtail quick-disconnect fitting; mating cordsets for QD models are ordered separately.
Operating Conditions	Temperature: -10° to +45° C Relative humidity: 90% at 50° C (non-condensing)
Weight	PD45: Sensor only: 22 g PD49: Sensor only: 28 g Sensor plus 2 m cable: 62 g Sensor plus 2 m cable: 68 g
Application Notes	False pulse may occur less than 1 second after power-up



QM42 Series

Rectangle Sensor with Mounting Versatility



- Versatile sensor with several mounting options
- Meets IP67 and NEMA 6 standards for harsh environment
- Universal housing design
- Cordsets and brackets see page 96

Opposed QM42, 10-30 V DC

⇒ Infrared LED

Sensing Mode	Range	Connection	Models NPN	Models PNP
	10 m	2 m	QM426E Emitter	
		4-Pin Euro QD	QM426EQ Emitter	
		2 m	QM42VN6R	QM42VP6R
		4-Pin Euro QD	QM42VN6RQ	QM42VP6RQ

Polar Retro QM42, 10-30 V DC

→ Visible Red LED

Sensing Mode	Range	Connection	Models NPN	Models PNP
	3 m†	2 m	QM42VN6LP	QM42VP6LP
		4-Pin Euro QD	QM42VN6LPQ	QM42VP6LPQ

Diffuse QM42, 10-30 V DC

⇒ Infrared LED

Sensing Mode	Range	Connection	Models NPN	Models PNP
	400 mm	2 m	QM42VN6D	QM42VP6D
		4-Pin Euro QD	QM42VN6DQ	QM42VP6DQ

Adjustable-Field QM42, 10-30 V DC

→ Visible Red LED

Sensing Mode	Range	Connection	Models NPN	Models PNP
	5 mm to Cutoff point (adjustable from 50 to 150 mm)	2 m	QM42VN6AFV150	QM42VP6AFV150
		4-Pin Euro QD	QM42VN6AFV150Q	QM42VP6AFV150Q



QM42 Opposed, Retroreflective, Short-range Diffuse, and Short-range Adjustable-Field Model Suffix E, R, LP, D, AFV150 and FP

For more specifications see page 97.

Connection options: A model with a QD requires a mating cordset (see page 96).

For 9 m cable, add suffix W/30 to the 2 m model number (example, QM42VN6 LP W/30).

† Tested using a BRT-3 retroreflector. Actual range depends on the efficiency and reflective area of the retroreflector in use. See Accessories for more information.

QMT42 Series

Rectangle Sensor with Mounting Versatility



- Versatile sensor with several mounting options
- Meets IP67 and NEMA 6 standards for harsh environment
- Universal housing design
- All-purpose, go-to sensor for many application needs
- Cordsets and brackets see page 96

Diffuse QMT42, 10-30 V DC

⇒ Infrared LED

Sensing Mode	Range	Connection	Models NPN	Models PNP
 DIFFUSE	10 mm - 6 m	2 m	QMT42VN6DX	QMT42VP6DX
		4-Pin Euro QD	QMT42VN6DXQ	QMT42VP6DXQ

Fixed-Field QMT42, 10-30 V DC

⇒ Infrared LED

Sensing Mode	Range	Connection	Models NPN	Models PNP
 FIXED-FIELD	50 - 500 mm Cutoff	2 m	QMT42VN6FF500	QMT42VP6FF500
		4-Pin Euro QD	QMT42VN6FF500Q	QMT42VP6FF500Q
 FIXED-FIELD	50 - 750 mm Cutoff	2 m	QMT42VN6FF750	QMT42VP6FF750
		4-Pin Euro QD	QMT42VN6FF750Q	QMT42VP6FF750Q
 FIXED-FIELD	50 - 1000 mm Cutoff	2 m	QMT42VN6FF1000	QMT42VP6FF1000
		4-Pin Euro QD	QMT42VN6FF1000Q	QMT42VP6FF1000Q
 FIXED-FIELD	50 - 1500 mm Cutoff	2 m	QMT42VN6FF1500	QMT42VP6FF1500
		4-Pin Euro QD	QMT42VN6FF1500Q	QMT42VP6FF1500Q
 FIXED-FIELD	50 - 2000 mm Cutoff	2 m	QMT42VN6FF2000	QMT42VP6FF2000
		4-Pin Euro QD	QMT42VN6FF2000Q	QMT42VP6FF2000Q

Adjustable-Field QMT42, 10-30 V DC

⇒ Visible Red LED

Sensing Mode	Range	Connection	Models NPN	Models PNP
 LONG RANGE FIXED-FIELD	25 mm to Cutoff point (adjustable from 125 to 400 mm)	2 m	QMT42VN6AFV400	QMT42VP6AFV400
		4-Pin Euro QD	QMT42VN6AFV400Q	QMT42VP6AFV400Q

For more specifications see page 97.

Connection options: A model with a QD requires a mating cordset (see page 96).
For 9 m cable, add suffix W/30 to the 2 m model number (example, QM42VN6LP W/30).



QMT42 Long-range Diffuse, Fixed-Field and Adjustable-Field Model Suffix DX, FF and AFV400



4-Pin
MQDC-406
2 m (6.5')
MQDC-415
5 m (15')
MQDC-430
9 m (30')

Euro-Style
Straight connector models listed;
for right-angle, add **RA** to the end
of the model number (example,
MQDC-406RA)



SMB30SK



SMB46S



SMB46L

*Additional cordset information is available
See page page 758*

*Additional bracket information is available
See page page 723*

Reflectors



*Additional information is available
See page page 790*

Apertures



*Additional information is available
See page page 816*





QM42 and QMT42 Specifications

Sensing Beam	Opposed, Diffuse, Retroreflective, Fixed-Field and Fiber Optic: Infrared, 880 nm; Visible Red, 660 nm Adjustable-Field: Visible Red, 680 nm
Supply Voltage and Current	10 to 30 V dc (10% max. ripple) at less than: Opposed: 30 mA (emitter), 10 mA (receiver) Short-range diffuse and retroreflective: 20 mA Fiber optic: 30 mA Adjustable-Field: 50 mA Fixed -Field and long-range diffuse: 40 mA
Supply Protection Circuitry	Protected against reverse polarity and transient voltages
Output Configuration	Solid-state complementary; choose NPN (current sinking) or PNP (current sourcing) models
Output Rating	100 mA max. (each output) OFF-state leakage current: less than 5 μ A at 30 V dc ON-state saturation voltage: less than 1 V at 10 mA dc; less than 1.5 V at 100 mA dc
Output Protection Circuitry	Protected against false pulse on power-up and continuous overload or short circuit of outputs Overload trip point \geq 150 mA, typical at 20° C
Output Response Time	Opposed: 1 millisecond ON; 0.5 millisecond OFF Diffuse, Retroreflective, Adjustable-Field and Fixed-Field: 1 millisecond ON/OFF Plastic Fiber Optic: 0.25 millisecond ON/OFF
Delay at Power-up	100 milliseconds; outputs are non-conducting during this time
Repeatability	Opposed: 120 microseconds Diffuse, Retroreflective, Adjustable-Field and Fixed-Field: 250 microseconds Fiber Optic: 60 microseconds. Repeatability and response are independent of signal strength
Sensing Hysteresis	Long-range diffuse: less than 20% of set sensing distance Adjustable-Field: less than 7% of set cutoff distance Fixed-Field: 2000 mm models – less than 5% of set cutoff distance 1500 mm models – less than 4% of set cutoff distance 1000 mm models – less than 3% of set cutoff distance 750 mm models – less than 2% of set cutoff distance 500 mm models – less than 1% of set cutoff distance
Cutoff Point Tolerance	Fixed-Field: \pm 10% of nominal cutoff distance
Adjustments	All models (except emitters, Adjustable-Field, Fixed-Field and Long-range Diffuse): 15-turn slotted brass GAIN (sensitivity) adjustment potentiometer 150 mm Adjustable-Field: 12-turn slotted brass cutoff distance adjustment potentiometer 400 mm Adjustable-Field: 15-turn slotted brass cutoff distance adjustment potentiometer Long-range diffuse: 4-turn slotted GAIN (sensitivity) adjustment potentiometer Fixed-Field: No adjustments See datasheet for detailed information
Indicators	Two LEDs: Green and Yellow Solid Green: Power ON; Opposed emitters: Green power ON Green Flashing: output overloaded Solid Yellow: Light sensed; Light Operate (LO) Yellow Flashing: marginal excess gain See datasheet for detailed information
Construction	Housings are die-cast zinc alloy with black acrylic polyurethane finish; lenses are acrylic
Environmental Rating	IP67; NEMA 6
Connections	2 m or 9 m attached cable, or 4-pin Euro-style quick-disconnect fitting. QD cordsets are ordered separately. See page 96.
Operating Conditions	Temperature: Long-range Diffuse, Adjustable-Field and Fixed-Field: -20° to +55° C All others: -20° to +70° C Relative humidity: 90% at 50° C (non-condensing)
Certifications	



Right Angle

Right angle sensors offer industry standard 8, 18 and 30 mm barrel mounting options. The right angle housing allows mounting in confined areas, and easy viewing of LED indicators.

Series	Description	Max Sensing Range	Dimensions H x W x D	Protection Rating	Housing Material	Power Supply
	T8 Compact sensor provides reliable sensing without adjustments. Page 100	Opposed: 2 m Diffuse: 100 mm	19 x 16.3 x 15.8 mm	IP67; NEMA 6	ABS	10 to 30 V dc
	T18 Epoxy-encapsulated right-angle barrel sensors provide reliable sensing without adjustments. Page 102	Opposed: 20 m Retro: 2 m Polarized Retro: 2 m Diffuse: 500 mm Fixed-Field: 100 mm	Varies by model	QD models: IP6K Other models: IP67; NEMA 6	Thermoplastic Polyester	10 to 30 V dc, 20 to 250 V ac
	TM18 Robust die-cast metal sensors provide reliable sensing without adjustments in high-pressure washdown environments. Page 106	Opposed: 20 m Polarized Retro: 5.5 m Diffuse: 500 mm Fixed-Field: 100 mm	41 x 30 x 30 mm	QD models: IP6K Other models: IP67; NEMA 6	Zinc die-cast with nickel plating	10 to 30 V dc
	T30 Compact sensor provides reliable sensing without adjustments. Page 110	Opposed: 60 m Polarized Retro: 6 m Fixed-Field: 600 mm	51.5 x 40 x 44.8 mm	QD models: IP6K Other models: IP67; NEMA 6	Thermoplastic Polyester	10 to 30 V dc, 20 to 250 V ac

OTHER AVAILABLE MODELS



Q4X page 34



Q3X page 38



QS18 page 40



QS30 page 56

T8 Series

Self-Contained, Right-Angle Barrel-Mount



- Powerful optics
- Short-range background suppression
- Highly visible red sensing beam for easy alignment
- Easily replaces range-limited 8 mm inductive proximity sensors

Opposed T8

Visible Red LED

Sensing Mode	Range	Connection	Output Type	Models NPN	Models PNP
	2 m	2 m	—	T86EV Emitter	
		3-Pin Pico Pigtail QD		T86EVQ Emitter	
		2 m	LO	T8AN6R	T8AP6R
		3-Pin Pico Pigtail QD		T8AN6RQ	T8AP6RQ
2 m	DO	T8RN6R	T8RP6R		
3-Pin Pico Pigtail QD		T8RN6RQ	T8RP6RQ		

Diffuse T8

Visible Red LED

Sensing Mode	Range	Connection	Output Type	Models NPN	Models PNP
	50 mm	2 m	LO	T8AN6D50	T8AP6D50
		3-Pin Pico Pigtail QD		T8AN6D50Q	T8AP6D50Q
		2 m	DO	T8RN6D50	T8RP6D50
		3-Pin Pico Pigtail QD		T8RN6D50Q	T8RP6D50Q
	100 mm	2 m	LO	T8AN6D100	T8AP6D100
		3-Pin Pico Pigtail QD		T8AN6D100Q	T8AP6D100Q
		2 m	DO	T8RN6D100	T8RP6D100
		3-Pin Pico Pigtail QD		T8RN6D100Q	T8RP6D100Q

Connection options: A model with a QD requires a mating cordset.

For 9 m cable, add suffix W/30 to the 2 m model number (example, T8AN6D50 W/30).



Pico-Style
Straight connector models listed; for right-angle, add **RA** to the end of the model number (example, **PKG3M-2RA**)

4-Pin	
PKG3M-2	PKG3M-9
2 m (6.5')	9 m (29.5')
PKG3M-5	PKG3M-10
5 m (16.4')	10 m (32.8')
PKG3M-7	
7 m (22.9')	



SMB8MM

Additional bracket information is available
See page 723

Additional cordset information is available
See page 758



Opposed and Diffuse Models
Suffix E, R and D

T8 Specifications

Supply Voltage and Current	10 to 30 V dc (10% max. ripple) at less than 25 mA (exclusive of load)
Supply Protection Circuitry	Protected against reverse polarity and transient voltages
Output Configuration	Solid-state switch NPN (current sinking) or PNP (current sourcing), depending on model. Light Operate (LO) or Dark Operate (DO), depending on model
Output Rating	50 mA max. OFF-state leakage current: less than 1 μ A at 24 V dc ON-state saturation voltage: less than 0.25 V at 10 mA dc; less than 0.5 V at 50 mA dc
Output Protection Circuitry	Protected against false pulse on power-up and continuous overload or short circuit of outputs Overload trip point \geq 100 mA
Output Response Time	1 millisecond ON; 0.5 milliseconds OFF
Delay at Power-up	Maximum 100 milliseconds (150 milliseconds for Diffuse); output does not conduct during this time
Repeatability	Opposed: 100 microseconds Diffuse: 160 microseconds
Indicators	Opposed: Receiver has Green and Red LED Emitter has one Green LED Solid Green: power ON Solid Red: light sensed Flashing green: output overloaded Yellow flashing: marginal excess gain Diffuse: Red: light is sensed
Construction	Reinforced polycarbonate/ABS alloy housing, acrylic window with 8 mm ABS nut
Environmental Rating	IEC IP67; NEMA 6
Operating Conditions	Temperature: -20° to +55° C Relative humidity: 80% at 50° C (non-condensing)
Vibration and Mechanical Shock	Vibration: All models meet IEC 60068-2-6, IEC 60947-5-2, UL491 Section 40, MIL-STD-202F Method 201A; 10 to 60 Hz, 0.5 mm peak to peak Shock: All models meet IEC 60068-2-27, IEC 60947-5-2; 30g peak acceleration, 11 millisecond pulse duration, half-sine wave pulse shape
Certifications	CE

T18 Series

Self-Contained Sensors



- Completely epoxy-encapsulated barrel-mount sensors
- Design rated NEMA 6P, IP67
- Wide operating range from -40° C to +70° C
- Advanced diagnostics warn of marginal sensing conditions or output overload
- Cordsets and brackets see page 104

Opposed T18, 10-30 V DC

⇨ Infrared LED

Sensing Mode	Range	Connection	Models NPN	Models PNP
<p>OPPOSED</p>	20 m	2 m	T186E Emitter T186EQ Emitter T18SN6R T18SP6R T18SN6RQ T18SP6RQ	
		4-pin Euro QD		
		2 m		
		4-pin Euro QD		

Retro & Polar Retro T18, 10-30 V DC

⇨ Infrared LED ➔ Visible Red LED

Sensing Mode	Range	Connection	Models NPN	Models PNP
<p>RETRO</p>	2 m†	2 m	T18SN6L	T18SP6L
		4-pin Euro QD	T18SN6LQ	T18SP6LQ
<p>POLAR RETRO</p>	2 m†	2 m	T18SN6LP	T18SP6LP
		4-pin Euro QD	T18SN6LPQ	T18SP6LPQ

Diffuse T18, 10-30 V DC

⇨ Infrared LED

Sensing Mode	Range	Connection	Models NPN	Models PNP
<p>DIFFUSE</p>	500 mm	2 m	T18SN6D	T18SP6D
		4-pin Euro QD	T18SN6DQ	T18SP6DQ

Fixed-Field T18, 10-30 V DC

⇨ Infrared LED

Sensing Mode	Range	Connection	Models NPN	Models PNP
<p>FIXED-FIELD</p>	0 - 25 mm Cutoff	2 m	T18SN6FF25	T18SP6FF25
		4-pin Euro QD	T18SN6FF25Q	T18SP6FF25Q
<p>FIXED-FIELD</p>	0 - 50 mm Cutoff	2 m	T18SN6FF50	T18SP6FF50
		4-pin Euro QD	T18SN6FF50Q	T18SP6FF50Q
<p>FIXED-FIELD</p>	0 - 100 mm Cutoff	2 m	T18SN6FF100	T18SP6FF100
		4-pin Euro QD	T18SN6FF100Q	T18SP6FF100Q

For more specifications see page 105.

Connection options: A model with a QD requires a mating cordset (see page 104).

For 9 m cable, add suffix W/30 to the 2 m model number (example, T18SN6L W/30).

† Retroreflective range is specified using one model BRT-3 retroreflector. Actual sensing range may differ, depending on the efficiency and reflective area of the retroreflector used. See Accessories section for more information.

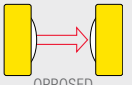

Opposed T18, 20-250 V AC

⇒ Infrared LED

Sensing Mode	Range	Connection	Models LO	Models DO
 OPPOSED	20 m	2 m 4-pin Micro QD 2 m 4-pin Micro QD	T183E Emitter T183EQ1 Emitter T18AW3R T18AW3RQ1	T18RW3R T18RW3RQ1

Retro & Polar Retro T18, 20-250 V AC

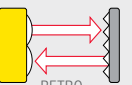
⇒ Infrared LED → Visible Red LED

Sensing Mode	Range	Connection	Models LO	Models DO
 RETRO	2 m [†]	2 m 4-pin Micro QD	T18AW3L T18AW3LQ1	T18RW3L T18RW3LQ1
 POLAR RETRO	2 m [†]	2 m 4-pin Micro QD	T18AW3LP T18AW3LPQ1	T18RW3LP T18RW3LPQ1

Diffuse T18, 20-250 V AC

⇒ Infrared LED

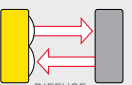
Sensing Mode	Range	Connection	Models LO	Models DO
 DIFFUSE	300 mm	2 m 4-pin Micro QD	T18AW3D T18AW3DQ1	T18RW3D T18RW3DQ1

T18, 20-250 V AC

⇒ Infrared LED

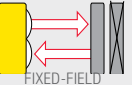
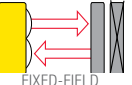
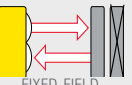
Sensing Mode	Range	Connection	Models LO	Models DO
 FIXED-FIELD	0 - 25 mm Cutoff	2 m 4-pin Micro QD	T18AW3FF25 T18AW3FF25Q1	T18RW3FF25 T18RW3FF25Q1
 FIXED-FIELD	0 - 50 mm Cutoff	2 m 4-pin Micro QD	T18AW3FF50 T18AW3FF50Q1	T18RW3FF50 T18RW3FF50Q1
 FIXED-FIELD	0 - 100 mm Cutoff	2 m 4-pin Micro QD	T18AW3FF100 T18AW3FF100Q1	T18RW3FF100 T18RW3FF100Q1

For more specifications see page 106.

 Connection options: A model with a QD requires a mating cordset (see page 104).

For 9 m cable, add suffix W/30 to the 2 m model number (example, T18SN6L W/30).

[†] Retroreflective range is specified using one model BRT-3 retroreflector. Actual sensing range may differ, depending on the efficiency and reflective area of the retroreflector used. See Accessories section for more information.



Euro-Style
Straight connector models listed;
for right-angle, add **RA** to the end
of the model number (example,
MQDC-406RA)

4-Pin
MQDC-406
2 m (6.5')
MQDC-415
5 m (15')
MQDC-430
9 m (30')



Micro-Style
Straight connector models listed;
for right-angle, add **RA** to the end
of the model number (example,
MQDC-306RA)

4-Pin
MQAC-406
2 m (6.5')
MQAC-415
5 m (15')
MQAC-430
9 m (30')

Additional cordset information is available
See page 758



DC Sensors (all models)



SMB18A



SMBAMS18P

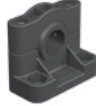

SMB1815SF



SMB18FM

Additional bracket information is available
See page 723



AC Sensors (all models)

Reflectors



Additional information is available
See page 790

Apertures



Additional information is available
See page 816

T18 Specifications

Supply Voltage and Current	<p>T18 DC 10 to 30 V dc (10% max. ripple); Supply current (exclusive of load current): Opposed Emitters: 25 mA Opposed Receivers: 20 mA Polarized Retroreflective: 30 mA Non-polarized Retroreflective: 25 mA Diffuse: 25 mA Fixed-Field: 35 mA</p> <p>T18AC 20 to 250 V ac (50/60 Hz) Average current: 20 mA Peak current: 200 mA at 20 V ac, 500 mA at 120 V ac, 750 mA at 250 V ac</p>
Supply Protection Circuitry	Protected against reverse polarity and transient voltages
Output Configuration	<p>T18 DC Solid-state complementary dc switch; NPN (current sinking) or PNP (current sourcing), depending on model. The Dark Operate (DO) output may be wired as a normally open marginal signal alarm output, depending upon hookup to the power supply.</p> <p>T18AC Solid-state ac switch; three-wire hookup; Light Operate (LO) or Dark Operate (DO), depending on model Light Operate: Output conducts when the sensor sees its own (or the emitter's) modulated light Dark Operate: Output conducts when sensor sees dark</p>
Output Rating	<p>T18 DC 150 mA max. (each) in standard hookup. When wired for alarm output, the total load may not exceed 150 mA. OFF-state leakage current: less than 1 μA at 30 V dc ON-state saturation voltage: less than 1 V at 10 mA dc; less than 1.5 V at 150 mA dc</p> <p>T18 AC 300 mA max. (continuous) Fixed-Field: derate 5 mA/$^{\circ}$ C above +50$^{\circ}$ C Inrush capability: 1 amp for 20 milliseconds, non-repetitive OFF-state leakage current: less than 100 μA ON-state voltage drop: 3 V at 300 mA ac; 2 V at 15 mA ac</p>
Output Protection Circuitry	Protected against false pulse on power-up and continuous overload or short circuit of outputs
Output Response Time	<p>T18 DC Opposed: 3 milliseconds ON, 1.5 milliseconds OFF Polarized Retroreflective, Non-polarized Retroreflective, Fixed-Field and Diffuse: 3 milliseconds ON/OFF</p> <p>T18 AC Opposed: 16 milliseconds ON, 8 milliseconds OFF Polarized Retroreflective, Non-polarized Retroreflective, Fixed-Field and Diffuse: 16 milliseconds ON/OFF</p>
Delay at Power-up	100 milliseconds; outputs are non-conducting during this time
Adjustments	T18 Series infrared non-polarized retroreflective and diffuse mode models (only) have a single-turn SENSITIVITY control for adjustment of system gain
Repeatability	<p>T18 DC Opposed: 375 microseconds Polarized Retroreflective, Non-polarized Retroreflective, Fixed-Field and Diffuse: 750 microseconds Repeatability and response are independent of signal strength</p> <p>T18 AC Opposed: 2 milliseconds Polarized Retroreflective, Non-polarized Retroreflective, Fixed-Field and Diffuse: 4 milliseconds Repeatability and response are independent of signal strength.</p>
Indicators	<p>Two LEDs: Solid Green: Power ON Flashing Green: output overloaded Solid Yellow: Light Operate (LO) output energized Flashing Yellow: marginal excess gain</p>
Construction	Housings are thermoplastic polyester. Lenses are polycarbonate or acrylic; one jam nut included.
Environmental Rating	Leakproof design rated NEMA 6P, IP67. QD models rated IP69K per DIN 40050-9
Connections	2 m or 9 m attached cable, or 4-pin Euro-style quick-disconnect fitting. QD cordsets are ordered separately. See page 104.
Operating Conditions	Temperature: -40 $^{\circ}$ to +70 $^{\circ}$ C Relative humidity: 90% at 50 $^{\circ}$ C (non-condensing)
Vibration and Mechanical Shock	All models meet Mil. Std. 202F requirements. Method 201A (Vibration; frequency 10 to 60 Hz, max., double amplitude 0.06-inch acceleration 10G). Method 213B conditions H&I (Shock: 75G with unit operating; 100G for non-operation)
Certifications	 <p>ECOLAB[®] chemical compatibility pending on some models; contact Banner Engineering for details</p>

TM18 Series

Heavy-Duty, Right Angle, Metal Sensors



- Robust die-cast metal sensors provide reliable sensing without adjustments
- Extremely bright LED red sensing beam for easy alignment
- Quick-disconnect models available
- Fixed-field models have enhanced immunity to fluorescent lights
- Polarized/fixed-field models have crosstalk avoidance so two sensors can be in close proximity
- Cordsets and brackets see page 90

Opposed TM18

➔ Visible Red LED

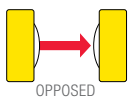
Sensing Mode	Range	Connection	Output Type	Models NPN	Models PNP
	20 m	2 m 4-pin Euro QD	—	TM186E Emitter TM186EQ8 Emitter	
		2 m 4-pin Euro QD	LO	TM18AN6R TM18AN6RQ8	TM18AP6R TM18AP6RQ8
		2 m 4-pin Euro QD	DO	TM18RN6R TM18RN6RQ8	TM18RP6R TM18RP6RQ8
		2 m 4-pin Euro QD	LO/DO	TM18VN6R TM18VN6RQ8	TM18VP6R TM18VP6RQ8

Polar Retro TM18

➔ Visible Red LED

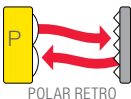
Sensing Mode	Range	Connection	Output Type	Models NPN	Models PNP
	5.5 m†	2 m 4-pin Euro QD	LO	TM18AN6LP TM18AN6LPQ8	TM18AP6LP TM18AP6LPQ8
		2 m 4-pin Euro QD	DO	TM18RN6LP TM18RN6LPQ8	TM18RP6LP TM18RP6LPQ8
		2 m 4-pin Euro QD	LO/DO	TM18VN6LP TM18VN6LPQ8	TM18VP6LP TM18VP6LPQ8

For more specifications see page 109.

➔ Connection options: A model with a QD requires a mating cordset (see page 108).
 For 9 m cable, add suffix W/30 to the 2 m model number (example, TM186E W/30).
 QD models: For a 4-pin 150 mm Euro-style pigtail QD, add suffix Q5 to the 2 m model number (example, TM186EQ5).

Diffuse TM18

➔ Visible Red LED

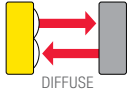
Sensing Mode	Range	Connection	Output Type	Models NPN	Models PNP
	500 mm	2 m 4-pin Euro QD	LO	TM18AN6DV TM18AN6DVQ8	TM18AP6DV TM18AP6DVQ8
		2 m 4-pin Euro QD	DO	TM18RN6DV TM18RN6DVQ8	TM18RP6DV TM18RP6DVQ8
		2 m 4-pin Euro QD	LO/DO	TM18VN6DV TM18VN6DVQ8	TM18VP6DV TM18VP6DVQ8

Fixed-Field TM18

➔ Visible Red LED ➔ Infrared LED

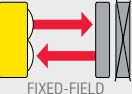
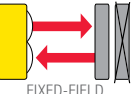
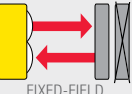
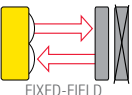
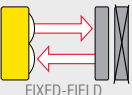
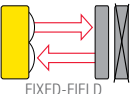
Sensing Mode	Range	Connection	Output Type	Models NPN	Models PNP
	25 mm	2 m 4-pin Euro QD	LO	TM18AN6FF25 TM18AN6FF25Q8	TM18AP6FF25 TM18AP6FF25Q8
		2 m 4-pin Euro QD	LO/DO	TM18VN6FF25 TM18VN6FF25Q8	TM18VP6FF25 TM18VP6FF25Q8
	50 mm	2 m 4-pin Euro QD	LO	TM18AN6FF50 TM18AN6FF50Q8	TM18AP6FF50 TM18AP6FF50Q8
		2 m 4-pin Euro QD	LO/DO	TM18VN6FF50 TM18VN6FF50Q8	TM18VP6FF50 TM18VP6FF50Q8
	100 mm	2 m 4-pin Euro QD	LO	TM18AN6FF100 TM18AN6FF100Q8	TM18AP6FF100 TM18AP6FF100Q8
		2 m 4-pin Euro QD	LO/DO	TM18VN6FF100 TM18VN6FF100Q8	TM18VP6FF100 TM18VP6FF100Q8
	25 mm	2 m 4-pin Euro QD	LO	TM18AN6FF25IR TM18AN6FF25IRQ8	TM18AP6FF25IR TM18AP6FF25IRQ8
		2 m 4-pin Euro QD	LO/DO	TM18VN6FF25IR TM18VN6FF25IRQ8	TM18VP6FF25IR TM18VP6FF25IRQ8
	50 mm	2 m 4-pin Euro QD	LO	TM18AN6FF50IR TM18AN6FF50IRQ8	TM18AP6FF50IR TM18AP6FF50IRQ8
		2 m 4-pin Euro QD	LO/DO	TM18VN6FF50IR TM18VN6FF50IRQ8	TM18VP6FF50IR TM18VP6FF50IRQ8
	100 mm	2 m 4-pin Euro QD	LO	TM18AN6FF100IR TM18AN6FF100IRQ8	TM18AP6FF100IR TM18AP6FF100IRQ8
		2 m 4-pin Euro QD	LO/DO	TM18VN6FF100IR TM18VN6FF100IRQ8	TM18VP6FF100IR TM18VP6FF100IRQ8

For more specifications see page 109.

➔ Connection options: A model with a QD requires a mating cordset (see page 108).
 For 9 m cable, add suffix W/30 to the 2 m model number (example, TM18AP6FF25 W/30).
 QD models: For a 4-pin 150 mm Euro-style pigtail QD, add suffix Q5 to the 2 m model number (example, TM18AP6FF25Q5).



4-Pin
MQDC-406
 2 m (6.5')
MQDC-415
 5 m (15')
MQDC-430
 9 m (30')

Euro-Style

Straight connector models listed; for right-angle, add **RA** to the end of the model number (example, **MQDC-406RA**)

Additional cordset information is available
 See page 758



Opposed, Polar Retroreflective, Diffuse and Fixed-Field Models
 Suffix E, R, LP, DV and FF



SMB18A



SMBAMS18P



SMBT18Y

Additional bracket information is available
 See page 723

Reflectors



Additional information is available
 See page 790

Apertures



Additional information is available
 See page 816

T30 Series

Long-Range with Superior Durability



- Epoxy-encapsulated sensors provide reliable sensing without adjustments.
- Features 30 mm plastic threaded barrel
- Available in opposed, retroreflective and fixed-field modes
- Designed for use in harsh sensing environments
- Advanced diagnostics warn of marginal sensing conditions or output overload
- Cordsets and brackets see page 112

Opposed T30, 10-30 V DC

Infrared LED

Sensing Mode	Range	Connection	Models NPN	Models PNP
<p>OPPOSED</p>	60 m	2 m	T306E Emitter	
		4-Pin Euro QD	T306EQ Emitter	
		2 m	T30SN6R	T30SP6R
		4-Pin Euro QD	T30SN6RQ	T30SP6RQ

Polar Retro T30, 10-30 V DC

Visible Red LED

Sensing Mode	Range	Connection	Models NPN	Models PNP
<p>POLAR RETRO</p>	6 m†	2 m	T30SN6LP	T30SP6LP
		4-Pin Euro QD	T30SN6LPQ	T30SP6LPQ

Fixed-Field T30, 10-30 V DC

Infrared LED

Sensing Mode	Range	Connection	Models NPN	Models PNP
<p>FIXED-FIELD</p>	0 - 200 mm Cutoff	2 m	T30SN6FF200	T30SP6FF200
		4-Pin Euro QD	T30SN6FF200Q	T30SP6FF200Q
<p>FIXED-FIELD</p>	0 - 400 mm Cutoff	2 m	T30SN6FF400	T30SP6FF400
		4-Pin Euro QD	T30SN6FF400Q	T30SP6FF400Q
<p>FIXED-FIELD</p>	0 - 600 mm Cutoff	2 m	T30SN6FF600	T30SP6FF600
		4-Pin Euro QD	T30SN6FF600Q	T30SP6FF600Q

For more specifications see page 112.

Connection options: A model with a QD requires a mating cordset (see page 112).

For 9 m cable, add suffix W/30 to the 2 m model number (example, T30SN6LP W/30).

† Retroreflective range is specified using a BRT-3 retroreflector.

Actual sensing range may differ, depending on the efficiency and reflective area of the retroreflector used. See Accessories for more information.

Opposed T30, 20-250 V AC

 Infrared LED

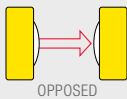
Sensing Mode	Range	Connection	Models Light Operate	Models Dark Operate
 OPPOSED	60 m	2 m 4-Pin Micro QD 2 m 4-Pin Micro QD	T303E Emitter T303EQ1 Emitter T30AW3R T30AW3RQ1	T30RW3R T30RW3RQ1

Polar Retro T30, 20-250 V AC

 Visible Red LED

Sensing Mode	Range	Connection	Models Light Operate	Models Dark Operate
 POLAR RETRO	6 m†	2 m 4-Pin Micro QD	T30AW3LP T30AW3LPQ1	T30RW3LP T30RW3LPQ1

Fixed-Field T30, 20-250 V AC

 Infrared LED

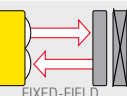
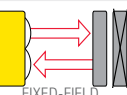
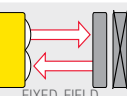
Sensing Mode	Range	Connection	Models Light Operate	Models Dark Operate
 FIXED-FIELD	0 - 200 mm Cutoff	2 m 4-Pin Euro QD	T30AW3FF200 T30AW3FF200Q1	T30RW3FF200 T30RW3FF200Q1
 FIXED-FIELD	0 - 400 mm Cutoff	2 m 4-Pin Euro QD	T30AW3FF400 T30AW3FF400Q1	T30RW3FF400 T30RW3FF400Q1
 FIXED-FIELD	0 - 600 mm Cutoff	2 m 4-Pin Euro QD	T30AW3FF600 T30AW3FF600Q1	T30RW3FF600 T30RW3FF600Q1

For more specifications see page 112.

 Connection options: A model with a QD requires a mating cordset (see page 112).

For 9 m cable, add suffix W/30 to the 2 m model number (example, T30AW3LP W/30).

† Retroreflective range is specified using a BRT-3 retroreflector.

Actual sensing range may differ, depending on the efficiency and reflective area of the retroreflector used. See Accessories for more information.



Euro-Style
Straight connector models listed; for right-angle, add **RA** to the end of the model number (example, **MQDC-406RA**)

4-Pin
MQDC-406
2 m (6.5')
MQDC-415
5 m (15')
MQDC-430
9 m (30')



Micro-Style
Straight connector models listed; for right-angle, add **RA** to the end of the model number (example, **MQDC-306RA**)

4-Pin
MQAC-406
2 m (6.5')
MQAC-415
5 m (15')
MQAC-430
9 m (30')



Opposed, Polarized Retroreflective and Fixed-field Models
Suffix E, R, LP and FF

Additional cordset information is available
See page 758



SMB30A



SMBAMS30P

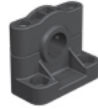

SMB1815SF



SMB30FA..

Additional bracket information is available
See page 723

Reflectors



Additional information is available
See page 790

Apertures



Additional information is available
See page 816

T30 DC Specifications

Supply Voltage and Current	10 to 30 V dc (10% max. ripple); Supply current (exclusive of load current): Opposed Emitters: 25 mA Opposed Receivers: 20 mA Polarized Retroreflective: 30 mA Fixed-Field: 35 mA
Supply Protection Circuitry	Protected against reverse polarity and transient voltages
Output Configuration	Solid-state dc switch; three-wire hookup; choose Light Operate (LO) or Dark Operate (DO) models Light Operate: Output conducts when the sensor sees its own (or the emitter's) modulated light Dark Operate: Output conducts when sensor sees dark
Output Rating	150 mA max. (each) in standard hookup; When wired for alarm output, the total load may not exceed 150 mA OFF-state leakage current: less than 1 µA at 30 V dc ON-state saturation voltage: less than 1 V at 10 mA dc; less than 1.5 V at 150 mA dc
Output Protection Circuitry	Protected against false pulse on power-up and continuous overload or short circuit of outputs
Output Response Time	Opposed: 3 milliseconds ON; 1.5 milliseconds OFF Polarized Retroreflective and Fixed-Field: 3 milliseconds ON/OFF
Delay at Power-up	100 milliseconds; outputs are non-conducting during this time
Repeatability	Opposed: 375 microseconds Polarized Retroreflective and Fixed-Field 750 microseconds Repeatability and response are independent of signal strength.
Indicators	Two LEDs: Solid Green: Power ON Flashing Green: output overload Solid Yellow: Light operate (LO) output energized Flashing Yellow: marginal excess gain
Construction	Housings are thermoplastic polyester. Lenses are polycarbonate or acrylic; one jam nut included.
Environmental Rating	Leakproof design rated NEMA 6P, IP67. QD models rated IP69K per DIN 40050-9.
Connections	2 m or 9 m attached cable, or 4-pin Euro-style quick-disconnect fitting. QD cordsets are ordered separately. See page 112.
Operating Conditions	Temperature: -40° to +70° C Relative humidity: 90% at 50° C (non-condensing)
Vibration and Mechanical Shock	All models meet Mil. Std. 202F requirements. Method 201A (Vibration; frequency 10 to 60 Hz, max., double amplitude 0.06-inch acceleration 10G). Method 213B conditions H&I (Shock: 75G with unit operating; 100G for non-operation)
Certifications	ECOLAB® chemical compatibility pending on some models; contact Banner Engineering for details

T30 AC Specifications

Supply Voltage and Current	20 to 250 V ac (50/60 Hz). Average current: 20 mA Peak current: 200 mA at 20 V ac, 500 mA at 120 V ac, 750 mA at 250 V ac
Supply Protection Circuitry	Protected against transient voltages
Output Configuration	Solid-state ac switch; three-wire hookup; choose Light Operate (LO) or Dark Operate (DO) models Light Operate: Output conducts when the sensor sees its own (or the emitter's) modulated light Dark Operate: Output conducts when sensor sees dark
Output Rating	300 mA max. (continuous) Fixed-Field: derate 5 mA/° C above +50° C Inrush capability: 1 amp for 20 milliseconds, non-repetitive OFF-state leakage current: less than 100 µA ON-state voltage drop: 3 V at 300 mA ac; 2 V at 15 mA ac
Output Protection Circuitry	Protected against false pulse on power-up
Output Response Time	Opposed: 16 milliseconds ON; 8 milliseconds OFF Polarized Retroreflective and Fixed-Field: 16 milliseconds ON/OFF
Delay at Power-up	100 milliseconds
Repeatability	Opposed: 2 milliseconds Polarized Retroreflective and Fixed-Field: 4 milliseconds Repeatability and response are independent of signal strength
Indicators	Two LEDs: Solid Green: Power ON Solid Yellow: Light sensed Flashing Yellow: marginal excess gain
Construction	Housings are thermoplastic polyester. Lenses are polycarbonate or acrylic; one jam nut included.
Environmental Rating	Leakproof design rated NEMA 6P, IP67. QD models rated IP69K per DIN 40050-9.
Connections	2 m or 9 m attached cable, or 4-pin Micro-style quick-disconnect fitting. QD cordsets are ordered separately. See page 112.
Operating Conditions	Temperature: -40° to +70° C Relative humidity: 90% at 50° C (non-condensing)
Vibration and Mechanical Shock	All models meet Mil. Std. 202F requirements. Method 201A (Vibration; frequency 10 to 60 Hz, max, double amplitude 0.06-inch acceleration 10G). Method 213B conditions H&I (Shock: 75G with unit operating; 100G for non-operation)
Certifications	



Barrel Sensors

Barrel sensors are available in industry standard 12, 18 and 30 mm barrel mounting options. The compact barrel size allows for easy replacement and easy viewing of LED indicators.

Series	Description	Max Sensing Range	Dimensions H x W x D	Protection Rating	Housing Material	Power Supply
	M12 Rugged, threaded metal sensor with fully encapsulated electronics. Page 116	Opposed: 5 m Retro: 2.5 m Polarized Retro: 1.5 m Diffuse: 400 mm Fixed-Field: 75 mm	12 ø x 67.5 mm	IEC IP67; NEMA 6, IEC IP68 and 1200 PSI washdown	Nickel-plated brass	10 to 30 V dc
	S12-2/S12 Barrel sensors provide reliable sensing without adjustments. Page 118	Opposed: 20 m	S12-2: 30.4 x ø 12 mm S12: 64 x ø 12 mm	IEC IP67; NEMA 6	Thermoplastic Polyester	10 to 30 V dc
	SB12/SB12T Economical sensors provide reliable sensing without adjustments. Page 120	Opposed: 1.5 m	SB12: 15.8 ø x 31 mm SB12T: 15.8 ø x 30.4 mm	IEC IP67; NEMA 6	Thermoplastic Polyester	10 to 30 V dc
	S18 Epoxy-encapsulated barrel sensors operate on dc voltage and provide reliable sensing without adjustments. Page 124	Opposed: 20 m Retro: 2 m Polarized Retro: 2 m Diffuse: 300 mm Fixed-Field: 100 mm	ø 18 x 58.8 mm	QD models: IP69K Other models: IEC IP67; NEMA 6	Thermoplastic Polyester	10 to 30 V dc 20 to 250 V ac
	S18-2 A self-contained powerful sensor with bright visible red emitter beam for easy alignment and set-up. Page 122	Opposed: 25 m Polarized Retro: 6m Retro: 7.5 m Diffuse: 750 mm Fixed-Field: 200 mm	Varies by model	IEC IP67; NEMA 6	Thermoplastic Polyester	10 to 30 V dc
	M18 Epoxy-encapsulated metal barrel sensors provide reliable sensing without adjustments. Page 126	Opposed: 20 m Retro: 2 m Polarized Retro: 2 m Diffuse: 300 mm Fixed-Field: 100 mm	18 ø x 59.2 mm	QD models: IP69K Other models: IEC IP67; NEMA 6	Stainless steel	10 to 30 V dc
	M18-3 Nickel plated brass housing is well protected against industrial fluids and mechanical damage. Page 128	Opposed: 25 m Retro: 6 m Polarized Retro: 7.5 m Diffuse: 750 mm Fixed-Field: 200 mm	18 ø x 63.5 mm	IEC IP67 and IP69K	Nickel-plated	10 to 30 V dc
	M18-4 Epoxy-encapsulated metal barrel sensors provide reliable sensing without adjustments. Page 130	Opposed: 25 m Retro: 6 m Polarized Retro: 7.5 m Diffuse: 750 mm Fixed-Field: 200 mm	18 ø x 63.5 mm	IEC IP67, IP68 and IP69K	Stainless steel	10 to 30 V dc
	S30 Epoxy-encapsulated sensors provide superior durability and reliable sensing over a long range. Page 138	Opposed: 60 m Polarized Retro: 6 m Fixed-Field: 600 mm	Varies by model	QD models: IP69K Other models: IEC IP67; NEMA 6	Thermoplastic Polyester	10 to 30 V dc 20 to 250 V ac
	SM30 Powerful epoxy-encapsulated sensor with a long range and the stainless steel model can be used in abusive environments. Page 140	Opposed: 150 m	30 ø x 102 mm	IEC IP67; NEMA 6	Thermoplastic Polyester or Stainless steel	10 to 30 V dc 24 to 240 V ac

M12 Series

Metal Barrel-Mount Sensors



- Metal sensor with fully encapsulated electronics.
- Easily replaces inductive sensors when target is too close to the sensor
- Available in NEMA 6P, IP67, IP69K and up to 1200 psi washdown depending on model
- Highly visible red sensing beam for easy alignment

Opposed M12

➔ Visible Red LED

Sensing Mode	Range	Connection	Models NPN	Models PNP
<p>OPPOSED</p>	5 m	2 m 4-Pin Euro QD	M12E (Emitter)	
	5 m	2 m 4-Pin Euro QD	M12NR M12NRQ8	M12PR M12PRQ8
			M12EQ8 (Emitter)	

Retro & Polar Retro M12

➔ Visible Red LED

Sensing Mode	Range	Connection	Models NPN	Models PNP
<p>RETRO</p>	2.5 m [†]	2 m	M12NLV	M12PLV
		4-Pin Euro QD	M12NLVQ8	M12PLVQ8
<p>POLAR RETRO</p>	1.5 m [†]	2 m	M12NLP	M12PLP
		4-Pin Euro QD	M12NLPQ8	M12PLPQ8

Fixed-Field M12

➔ Visible Red LED

Sensing Mode	Range	Connection	Models NPN	Models PNP
<p>FIXED-FIELD</p>	25 mm Cutoff	2 m	M12NFF25	M12PFF25
		4-Pin Euro QD	M12NFF25Q8	M12PFF25Q8
<p>FIXED-FIELD</p>	50 mm Cutoff	2 m	M12NFF50	M12PFF50
		4-Pin Euro QD	M12NFF50Q8	M12PFF50Q8
<p>FIXED-FIELD</p>	75 mm Cutoff	2 m	M12NFF75	M12PFF75
		4-Pin Euro QD	M12NFF75Q8	M12PFF75Q8

➔ Connection options: A model with a QD requires a mating cordset.

For 9 m cable, add suffix W/30 to the 2 m model number (example, M12PD W/30).

QD models: For a 4-pin 150 mm Euro-style pigtail QD, add suffix Q5 (example, M12PDQ5).

[†] Retroreflective range is specified using a BRT-84 retroreflector.

Actual sensing range may differ, depending on the efficiency and reflective area of the retroreflector used. See Accessories for more information.

Diffuse M12

→ Visible Red LED

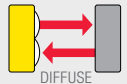
Sensing Mode	Range	Connection	Models NPN	Models PNP
	400 mm	2 m 4-Pin Euro QD	M12ND M12NDQ8	M12PD M12PDQ8

Euro QD (for Q5 models)
Straight connector models listed; for right-angle, add **RA** to the end of the model number (example, **MQDC-406RA**)



4-Pin
MQDC-406
2 m (6.')

MQDC-415
5 m (15')

MQDC-430
9 m (30')



SMBQS12PD
12-ga. stainless steel

Additional bracket information is available
See page 758

Additional bracket information is available
See page 723



Opposed, Retroreflective
Diffuse and Fixed-Field Models
Suffix E, R, LP, LV, D and FF

Reflectors



Additional information is available
See page 790

Apertures



Additional information is available
See page 816

M12 Specifications

Sensing Beam	Fixed-Field: 680 nm visible red All others: 660 nm visible red
Supply Voltage and Current	10 to 30 V dc (10% max. ripple) @ 20 mA max current (exclusive of load)
Supply Protection Circuitry	Protected against reverse polarity and transient voltages
Output Configuration	Complementary (1 normally open and 1 normally closed) solid-state, NPN or PNP, depending on model
Output Ratings	100 mA total across both outputs with overload and short circuit protection OFF-state leakage current: NPN: less than 200 µA @ 30 V dc (see Application Note) PNP: less than 10 µA @ 30 V dc ON-state saturation voltage: NPN: less than 1.6 V @ 100 mA PNP: less than 3.0 V @ 100 mA
Output Protection Circuitry	Protected against false pulse on power-up, short-circuit protected
Output Response Time	Opposed: 625 microsecond ON/375 microseconds OFF All others: 500 microseconds ON/OFF
Delay at Power-up	100 milliseconds; outputs do not conduct during this time
Repeatability	Opposed: 85 microseconds All others: 95 microseconds
Indicators	2 LED indicators: Solid Green: power ON Flashing Green: output overloaded Yellow: light sensed Flashing Yellow: marginal excess gain
Adjustments	Fixed-Field: none All others: single-turn Gain (sensitivity) potentiometer
Construction	Housing: Nickel-plated brass Lenses: PMMA Cable endcap and Gain potentiometer adjuster: PBT
Environmental Rating	IEC IP67; NEMA 6, IEC IP68 and 1200 PSI washdown, NEMA 1CS 5 Annex F-2002
Connections	2 m or 9 m 4-wire PVC-jacketed cable, 4-pin integral Euro-style QD (Q8), or 150 mm pigtail with 4-pin Euro-style quick-disconnect fitting (Q5), depending on model. QD cordsets ordered separately.
Operating Conditions	Operating temperature: -20° to +60° C Relative humidity: 90% max @ +50° C
Application Notes	NPN off-state leakage current is < 200 µA for load resistances > 3 kΩ or optically isolated loads. For load current of 100 mA, leakage is < 1% of load current
Certifications	

S12 Series

Plastic Barrel-Mount Sensors



- Housing rated to IP67 for heavy-duty industrial sensing
- Sensing range up to 20 m
- Wide beam pattern makes sensor alignment easy at long ranges
- Available in opposed mode

Opposed S12

➔ Visible Red LED

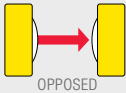
Sensing Mode	Range	Connection	Models NPN	Models PNP
 OPPOSED	15 m	2 m	S126E Emitter	
			S12SN6R	S12SP6R

Opposed S12-2

➔ Infrared LED

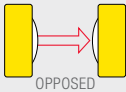
Sensing Mode	Range	Input	Connection	Models NPN	Models PNP
 OPPOSED	20 m	–	2 m	S12-2NAEL-2M Emitter	
		Beam Inhibit		S12-2NAEJ-2M Emitter	
		–		S12-2ANRL-2M	S12-2APRL-2M
		–		S12-2RNRL-2M	S12-2RPRL-2M

 Connection options: A model with a QD requires a mating cordset.
 QD models: For a 4-pin 150 mm Pico-style pigtail QD, add suffix QP (example, S12SN6RQP).



Pico QD (for Q models)
Straight connector models listed; for right-angle, **W** replaces **G** in the model number.
(example, **PKW4M-2**)

4-Pin
PKG4M-2
2 m (6')
PKG4M-5
5 m (15')
PKG4M-9
9 m (30')



Pico QD (for Q7 models)
Straight snap-on connector model
Pico QD (for Q7 models)
Right Angle' snap-on connector model

4-Pin
PKG4-2
2 m (6')
PKW4Z-2
2 m (6')

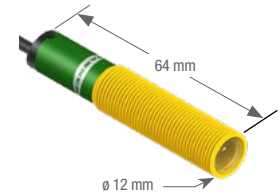

S12
Opposed Models

Additional cordset information is available
See page 758



SMB12MM

Additional bracket information is available
See page 723

Reflectors



Additional information is available
See page 790

Apertures



Additional information is available
See page 816



S12-2
Opposed Models

S12 & S12-2 Specifications

Supply Voltage and Current	S12: 10 to 30 V dc (10% max. ripple); 25 mA (emitters) or 20 mA (receivers) exclusive of load S12-2: 10 to 30 V dc; < 25 mA (emitters) or 15 mA (receivers) exclusive of load
Supply Protection Circuitry	Protected against reverse polarity and transient voltages
Output Configuration	S12: Complementary solid-state dc switch; choose NPN (current sinking) or PNP (current sourcing) models Light Operate: N.O. output conducts when the sensor sees the emitter's modulated light Dark Operate: N.C. output conducts when the sensor sees dark; The N.C. (normally closed) output may be wired as a normally open marginal signal alarm output, depending upon hookup to the power supply S12-2: One solid state output, NPN (sinking) or PNP (sourcing), depending on model
Output Ratings	100 mA maximum (each) in standard hookup; when wired for alarm output, the total load may not exceed 100 mA OFF-state leakage current: less than 1 µA @ 30 V dc ON-state saturation voltage: less than 1 V @ 10 mA; less than 1.5 V @ 150 mA
Output Protection Circuitry	Protected against false pulse on power-up and continuous overload or short circuit of outputs
Output Response Time	S12: 3 milliseconds ON, 1.5 milliseconds OFF S12-2: 11 milliseconds ON, 7 milliseconds OFF
Delay at Power-up	S12: 100 millisecond; outputs are non-conducting during this time S12-2: 1 second; outputs are non-conducting during this time
Repeatability	S12: 375 microseconds S12-2: 1.5 milliseconds
Indicators	Green LED (emitter and receiver): power ON Amber LED (receiver only): light sensed
Construction	Housings are reinforced thermoplastic polyester; lenses are Lexan®; Polyurethane end cap
Environmental Rating	Leakproof design rated NEMA 6P (IEC IP67)
Connections	S12: 2 m or 9 m cable, or a 150 mm pigtail with 4-pin Pico-style QD S12-2: 2 m or 9 m cable, or a 150 mm pigtail with 3-pin Pico-style QD QD cordset ordered separately.
Operating Conditions	S12: Temperature: -40° to +70° C Maximum relative humidity: 90% at 50°C (non-condensing) S12-2: Temperature: -25° to +50° C Maximum relative humidity: 90% at 50°C (non-condensing)
Vibration and Mechanical Shock	Meets Mil. Std. 202F requirements. Method 201A (Vibration: frequency 10 to 60 Hz, max., double amplitude 0.06-inch acceleration 10G). Method 213B conditions H&I (Shock: 75G with unit operating; 100G for non-operation).
Certifications	

Lexan® is a registered trademark of General Electric Co.

SB12 & SB12T

Plastic Barrel-Mount Sensors



- Narrow beam for precise leading edge detection
- Ideal for compact areas
- No adjustment necessary
- SB12T has a threaded housing for robust monitoring in applications with vibration, rough handling or vandalism

Opposed SB12

Infrared LED

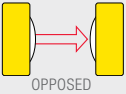
Sensing Mode	Range	Connection	Output	Models NPN	Models PNP
	1.5 m	2 m	- LO DO	SB12E1 Emitter	
				SB12ANR	SB12APR
				SB12RNR	SB12RPR

Opposed SB12T

Infrared LED

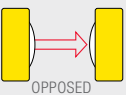
Sensing Mode	Range	Connection	Output	Models NPN	Models PNP
	1.5 m	2 m	- LO DO	SB12TE1 Emitter	
				SB12TANR	SB12TAPR
				SB12TRNR	SB12TRPR

Connection options: A model with a QD requires a mating cordset
 QD models: For a 3-pin 150 mm Pico-style pigtail QD, add suffix Q3 (example, SB12E1Q3).



4-Pin

Pico QD (for Q models)
Straight connector models listed; for right-angle, **W** replaces **G** in the model number. (example, **PKW4M-2**)

PKG4M-2
2 m (6')
PKG4M-5
5 m (15')
PKG4M-9
9 m (30')



4-Pin

Pico QD (for Q7 models)
Straight snap-on connector model
Pico QD (for Q7 models)
Right Angle snap-on connector model

PKG4-2
2 m (6')
PKW4Z-2
2 m (6')

Additional cordset information is available
See page 758



SMB12MM

Additional bracket information is available
See page 723



SB12
Opposed Models



SB12T
Opposed Models

SB12/SB12T Specifications

Supply Voltage and Current	10 to 30 V dc; less than 15 mA max exclusive of load	
Supply Protection Circuitry	Protected against reverse polarity and transient voltages	
Output Configuration	One solid state output, NPN (sinking) or PNP (sourcing), depending on model	
Output Ratings	SB12/SB12T: 100 mA OFF-state leakage current: < 10 µA ON-state saturation voltage: < 0.2 V @ 10 mA; < 0.6 V @ 100 mA	
Output Protection Circuitry	Protected against false pulse on power-up and continuous overload or short circuit of outputs	
Output Response Time	2.5 milliseconds ON, 1.75 milliseconds OFF	
Delay at Power-up	Less than 1 second	
Repeatability	350 microseconds	
Switching Frequency	235 Hz	
Indicators	Solid Green (emitter and receiver): power ON Solid Amber (receiver only): light sensed	Flashing Green (emitter and receiver): output short circuited Flashing Amber (receiver only): marginal excess gain
Construction	Housing: ABS Lens: Polycarbonate; epoxy encapsulant Cable: PVC-jacketed	
Environmental Rating	SB12: IP65	SB12T: IP67
Connections	2 m cable or 150 mm pigtail with 3-pin Pico-style QD. QD cordset ordered separately.	
Operating Conditions	Temperature: -20° to +50° C Maximum relative humidity: 90% at 50° C (non-condensing)	

Certifications



S18-2 Series

Plastic Barrel-Mount Sensors



- Bright visible red emitter beam for easy alignment and set-up
- Available in multiple operating modes
- Wide operating range from -40° C to +70° C
- High performance sensing
- Beam inhibit or gain adjustment on select models
- Cordsets and brackets see page 132

Opposed S18-2



Sensing Mode	Range	Connection	Models NPN	Models PNP	
<p>OPPOSED</p>	25 m	Emitter	2 m	S18-2NAEL-2M	
			4-pin Euro QD	S18-2NAEL-Q8	
			2 m	S18-2NAEJ-2M (with Beam inhibit)	
			4-pin Euro QD	S18-2NAEJ-Q8 (with Beam inhibit)	
			2 m	S18-2NAES-2M (with Adjustment)	
			4-pin Euro QD	S18-2NAEJ-Q8 (with Adjustment)	
<p>OPPOSED</p>	25 m	Receiver	2 m	S18-2VNLP-2M	S18-2VPLP-2M
			4-pin Euro QD	S18-2VNLP-Q8	S18-2VPLP-Q8
			2 m	M18-3VNRS-2M (with Adjustment)	M18-3VPRS-2M (with Adjustment)
			4-pin Euro QD	M18-3VNRS-Q8 (with Adjustment)	M18-3VPRS-Q8 (with Adjustment)

Polar Retro S18-2



Sensing Mode	Range*	Connection	Models NPN	Models PNP	
<p>POLAR RETRO</p>	6 m		2 m	S18-2VNLP-2M	S18-2VPLP-2M
			4-pin Euro QD	S18-2VNLP-Q8	S18-2VPLP-Q8
			2 m	S18-2VNLP-2M (with Adjustment)	S18-2VPLP-2M (with Adjustment)
			4-pin Euro QD	S18-2VNLP-Q8 (with Adjustment)	S18-2VPLP-Q8 (with Adjustment)

For more specifications see page 133.

Connection options: A model with a QD requires a mating cordset (see page 132).
 For a 9 m cable, add suffix 9M to the 2 m model number (example, S18-2NAEL-9M).
 For a 4-pin Euro M12 pigtail QD, add suffix Q5 to the model number (example, S18-2VNRL-Q5)
 For a 4-pin Pico M8 pigtail QD, add suffix Q3 to the model number (example, S18-2VNRL-Q3)
 * Range specified with BRT-84 reflector

Retro S18-2

➔ Visible Red LED

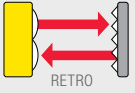
Sensing Mode	Range*	Connection	Models NPN	Models PNP
	7.5 m	2 m	S18-2VNLV-2M (with Adjustment)	S18-2VPLV-2M (with Adjustment)
		4-pin Euro QD	S18-2VNLV-Q8 (with Adjustment)	S18-2VPLV-Q8 (with Adjustment)

Diffuse S18-2

➔ Visible Red LED

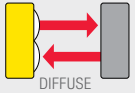
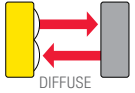
Sensing Mode	Range*	Connection	Models NPN	Models PNP
	750 mm	2 m	S18-2VNLD-2M (with Adjustment)	S18-2VPDL-2M (with Adjustment)
		4-pin Euro QD	S18-2VNLD-Q8 (with Adjustment)	S18-2VPDL-Q8 (with Adjustment)
	300 mm	2 m	S18-2VNDS-2M (with Adjustment)	S18-2VPDS-2M (with Adjustment)
		4-pin Euro QD	S18-2VNDS-Q8 (with Adjustment)	S18-2VPDS-Q8 (with Adjustment)

Fixed-Field S18-2

➔ Visible Red LED

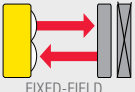
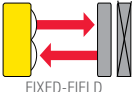
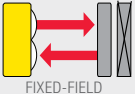
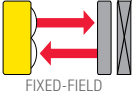
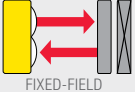
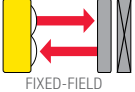
Sensing Mode	Range*	Connection	Models NPN	Models PNP
	30 mm	2 m	S18-2VNFF30-2M	S18-2VPFF30-2M
		4-pin Euro QD	S18-2VNFF30-Q8	S18-2VPFF30-Q8
	50 mm	2 m	S18-2VNFF50-2M	S18-2VPFF50-2M
		4-pin Euro QD	S18-2VNFF50-Q8	S18-2VPFF50-Q8
	75 mm	2 m	S18-2VNFF75-2M	S18-2VPFF75-2M
		4-pin Euro QD	S18-2VNFF75-Q8	S18-2VPFF75-Q8
	100 mm	2 m	S18-2VNFF100-2M	S18-2VPFF100-2M
		4-pin Euro QD	S18-2VNFF100-Q8	S18-2VPFF100-Q8
	150 mm	2 m	S18-2VNFF150-2M	S18-2VPFF150-2M
		4-pin Euro QD	S18-2VNFF150-Q8	S18-2VPFF150-Q8
	200 mm	2 m	S18-2VNFF200-2M	S18-2VPFF200-2M
		4-pin Euro QD	S18-2VNFF200-Q8	S18-2VPFF200-Q8

For more specifications see page 133.

➔ Connection options: A model with a QD requires a mating cordset (see page 132).
 For 9 m cable, add suffix 9M to the 2 m model number (example, S18-2NAEL-9M).
 For a 4-pin Euro M12 pigtail QD, add suffix Q5 to the model number (example, S18-2VNRL-Q5)
 For a 4-pin Pico M8 pigtail QD, add suffix Q3 to the model number (example, S18-2VNRL-Q3)
 * Range specified with BRT-84 reflector

S18 Series

Plastic Barrel-Mount Sensors

- Epoxy-encapsulated barrel sensors
- Available in multiple operating modes
- Meets IP69K standards
- Wide operating range from -40° C to +70° C
- Cordsets and brackets see page 132



Opposed S18, 10-30 V DC

Infrared LED

Sensing Mode	Range	Connection	Models NPN	Models PNP
	20 m	2 m	S18SN6R S18SN6RQ	S186E Emitter S186EQ Emitter S18SP6R S18SP6RQ
		4-pin Euro QD		

Retro and Polar Retro S18, 10-30 V DC

Infrared LED Visible Red LED

Sensing Mode	Range	Connection	Models NPN	Models PNP
	2 m*	2 m	S18SN6L	S18SP6L
		4-pin Euro QD	S18SN6LQ	S18SP6LQ
	2 m*	2 m	S18SN6LP	S18SP6LP
		4-pin Euro QD	S18SN6LPQ	S18SP6LPQ

Diffuse S18, 10-30 V DC

Infrared LED

Sensing Mode	Range	Connection	Models NPN	Models PNP
	100 mm	2 m	S18SN6D	S18SP6D
		4-pin Euro QD	S18SN6DQ	S18SP6DQ
	300 mm	2 m	S18SN6DL	S18SP6DL
		4-pin Euro QD	S18SN6DLQ	S18SP6DLQ

Fixed-Field S18, 10-30 V DC

Infrared LED

Sensing Mode	Range	Connection	Models NPN	Models PNP
	0 - 25 mm Cutoff	2 m	S18SN6FF25	S18SP6FF25
		4-pin Euro QD	S18SN6FF25Q	S18SP6FF25Q
	0 - 50 mm Cutoff	2 m	S18SN6FF50	S18SP6FF50
		4-pin Euro QD	S18SN6FF50Q	S18SP6FF50Q
	0 - 100 mm Cutoff	2 m	S18SN6FF100	S18SP6FF100
		4-pin Euro QD	S18SN6FF100Q	S18SP6FF100Q

For more specifications see page 133.

Connection options: A model with a QD requires a mating cordset (see page 132).
 For 9 m cable, add suffix W/30 to the 2 m model number (example, S18SP6R W/30).
 * Retroreflective range is specified using one model BRT-3 retroreflector, unless otherwise noted.
 Actual sensing range may differ, depending on the efficiency and reflective area of the retroreflector used. See Accessories section for more information.

Opposed S18, 20-250 V AC



Sensing Mode	Range	Connection	Models Light Operate	Models Dark Operate
<p>OPPOSED</p>	20 m	2 m	S183E Emitter	
		4-pin Micro QD	S183EQ1 Emitter	
		2 m	S18AW3R	S18RW3R
		4-pin Micro QD	S18AW3RQ1	S18RW3RQ1

Retro & Polar Retro S18, 20-250 V AC

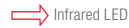

Sensing Mode	Range	Connection	Models Light Operate	Models Dark Operate
<p>RETRO</p>	2 m†	2 m	S18AW3L	S18RW3L
		4-pin Micro QD	S18AW3LQ1	S18RW3LQ1
<p>POLAR RETRO</p>	2 m†	2 m	S18AW3LP	S18RW3LP
		4-pin Micro QD	S18AW3LPQ1	S18RW3LPQ1

Diffuse S18, 20-250 V AC



Sensing Mode	Range	Connection	Models Light Operate	Models Dark Operate
<p>DIFFUSE</p>	100 mm	2 m	S18AW3D	S18RW3D
		4-pin Micro QD	S18AW3DQ1	S18RW3DQ1
	300 mm	2 m	S18AW3DL	S18RW3DL
		4-pin Micro QD	S18AW3DLQ1	S18RW3DLQ1

Fixed-Field S18, 20-250 V AC



Sensing Mode	Range	Connection	Models Light Operate	Models Dark Operate
<p>FIXED-FIELD</p>	0 - 25 mm Cutoff	2 m	S18AW3FF25	S18RW3FF25
		4-pin Micro QD	S18AW3FF25Q1	S18RW3FF25Q1
	0 - 50 mm Cutoff	2 m	S18AW3FF50	S18RW3FF50
		4-pin Micro QD	S18AW3FF50Q1	S18RW3FF50Q1
	0 - 100 mm Cutoff	2 m	S18AW3FF100	S18RW3FF100
		4-pin Micro QD	S18AW3FF100Q1	S18RW3FF100Q1

For more specifications see page 134.

Connection options: A model with a QD requires a mating cordset (see page 132).

For 9 m cable, add suffix W/30 to the 2 m model number (example, S183E W/30).

† Retroreflective range is specified using one model BRT-3 retroreflector, unless otherwise noted.

Actual sensing range may differ, depending on the efficiency and reflective area of the retroreflector used. See Accessories section for more information.

M18 Series

Metal Barrel-Mount Sensors



- Epoxy-encapsulated metal barrel sensors
- Available in multiple operating modes
- Meets IP69K standards
- Wide operating range from -40 to +70° C
- High performance sensing
- Cordsets and brackets see page 132

Opposed M18

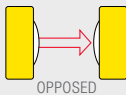

 Infrared LED

Sensing Mode	Range	Connection	Models NPN	Models PNP
	20 m	2 m	M186E Emitter	
		4-pin Euro QD	M186EQ Emitter	
		2 m	M18SN6R	M18SP6R
		4-pin Euro QD	M18SN6RQ	M18SP6RQ

Retro & Polar Retro M18

 Infrared LED

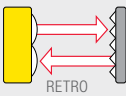
 Visible Red LED

Sensing Mode	Range	Connection	Models NPN	Models PNP
	2 m [†]	2 m	M18SN6L	M18SP6L
		4-pin Euro QD	M18SN6LQ	M18SP6LQ
	2 m [†]	2 m	M18SN6LP	M18SP6LP
		4-pin Euro QD	M18SN6LPQ	M18SP6LPQ

For more specifications see page 135.

 Connection options: A model with a QD requires a mating cordset (see page 132).

For 9 m cable, add suffix W/30 to the 2 m model number (example, M18SP6D W/30).

[†] Retroreflective range is specified using one model BRT-3 retroreflector, unless otherwise noted.
Actual sensing range may differ, depending on the efficiency and reflective area of the retroreflector used. See Accessories section for more information.

Diffuse M18

 Infrared LED

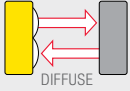
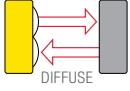
Sensing Mode	Range	Connection	Models NPN	Models PNP
	100 mm	2 m	M18SN6D-2M	M18SP6D-2M
		4-pin Euro QD	M18SN6DQ-Q8	M18SP6DQ-Q8
	300 mm	2 m	M18SN6DL-2M	M18SP6DL-2M
		4-pin Euro QD	M18SN6DLQ-Q8	M18SP6DLQ

Fixed-Field M18

 Infrared LED

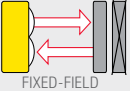
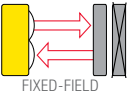
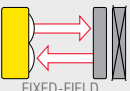
Sensing Mode	Range	Connection	Models NPN	Models PNP
	0 - 25 mm Cutoff	2 m	M18SN6FF25	M18SP6FF25
		4-pin Euro QD	M18SN6FF25Q	M18SP6FF25Q
	0 - 50 mm Cutoff	2 m	M18SN6FF50	M18SP6FF50
		4-pin Euro QD	M18SN6FF50Q	M18SP6FF50Q
	0 - 100 mm Cutoff	2 m	M18SN6FF100	M18SP6FF100
		4-pin Euro QD	M18SN6FF100Q	M18SP6FF100Q

For more specifications see page 135.

 Connection options: A model with a QD requires a mating cordset (see page 132).
 For 9 m cable, add suffix W/30 to the 2 m model number (example, M18SP6D W/30).

M18-3 Series

Heavy-Duty Metal Barrel-Mount Sensors



- Economical photoelectric sensors for cost sensitive and high volume installations
- Powerful and bright visible red emitter beam for easy alignment and set-up
- Advanced ASIC technology is resistant to optical and electrical noise source
- Robust 250° adjustment potentiometer on select models
- Cordsets and brackets see page 132

Opposed M18-3

➔ Visible Red LED

Sensing Mode	Range	Connection	Models NPN	Models PNP	
	25 m	Emitter	2 m	M186-3NAEL-2M	
			4-pin Euro QD	M186-3NAEL-Q8	
			2 m	M186-3NAEJ-2M (with Beam inhibit)	
			4-pin Euro QD	M186-3NAEJ-Q8 (with Beam inhibit)	
			2 m	M186-3NAES-2M (with Adjustment)	
	25 m	Receiver	4-pin Euro QD	M186-3NAES-Q8 (with Adjustment)	
			2 m	M18-3VNRL-2M	M18-3VPRL-2M
			4-pin Euro QD	M18-3VNRL-Q8	M18-3VPRL-Q8
			2 m	M18-3VNRS-2M (with Adjustment)	M18-3VPRS-2M (with Adjustment)
			4-pin Euro QD	M18-3VNRS-Q8 (with Adjustment)	M18-3VPRS-Q8 (with Adjustment)

Retro & Polar Retro M18-3

⇨ Infrared LED

➔ Visible Red LED

Sensing Mode	Range †	Connection	Models NPN	Models PNP
	7.5 m	2 m	M18-3VNLV-2M (with Adjustment)	M18-3VPLV-2M (with Adjustment)
		4-pin Euro QD	M18-3VNLV-Q8 (with Adjustment)	M18-3VPLV-Q8 (with Adjustment)
	2 m	2 m	M18-3VNLP-2M	M18-3VPLP-2M
		4-pin Euro QD	M18-3VNLP-Q8	M18-3VPLP-Q8
		2 m	M18-3VNLPC-2M (with Adjustment)	M18-3VPLPC-2M (with Adjustment)
		4-pin Euro QD	M18-3VNLPC-Q8 (with Adjustment)	M18-3VPLPC-Q8 (with Adjustment)

For more specifications see page 135.

➔ Connection options: A model with a QD requires a mating cordset (see page 132).

For 150 mm cable with a 4-pin M12/Euro-style quick disconnect model, add the suffix "Q5". For example, M18-3VNRLQ5.

† Retroreflective range is specified using one model BRT-84.

Actual sensing range may differ, depending on the efficiency and reflective area of the retroreflector used. See Accessories section for more information.

Diffuse M18-3

 Visible Red LED

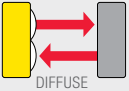
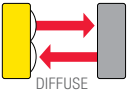
Sensing Mode	Range	Connection	Models NPN	Models PNP
 DIFFUSE	750 mm	2 m	M18-3VNDL-2M (Adjustment)	M18-3VPDL-2M (Adjustment)
		4-pin Euro QD	M18-3VNDL-Q8 (Adjustment)	M18-3VPDL-Q8 (Adjustment)
 DIFFUSE	300 mm	2 m	M18-3VNDS-2M (Adjustment)	M18-3VPDS-2M (Adjustment)
		4-pin Euro QD	M18-3VNDS-Q8 (Adjustment)	M18-3VPDS-Q8 (Adjustment)

Fixed-Field M18-3

 Visible Red LED

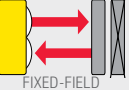
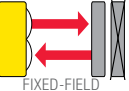
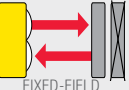
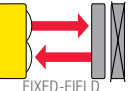
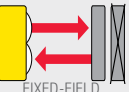
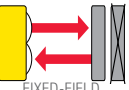
Sensing Mode	Range	Connection	Models NPN	Models PNP
 FIXED-FIELD	30 mm	2 m	M18-3VNFF30-2M	M18-3VPFF30-2M
		4-pin Euro QD	M18-3VNFF30-Q8	M18-3VPFF30-Q8
 FIXED-FIELD	50 mm	2 m	M18-3VNFF50-2M	M18-3VPFF50-2M
		4-pin Euro QD	M18-3VNFF50-Q8	M18-3VPFF50-Q8
 FIXED-FIELD	75 mm	2 m	M18-3VNFF75-2M	M18-3VPFF75-2M
		4-pin Euro QD	M18-3VNFF75-Q8	M18-3VPFF75-Q8
 FIXED-FIELD	100 mm	2 m	M18-3VNFF100-2M	M18-3VPFF100-2M
		4-pin Euro QD	M18-3VNFF100-Q8	M18-3VPFF100-Q8
 FIXED-FIELD	150 mm	2 m	M18-3VNFF150-2M	M18-3VPFF150-2M
		4-pin Euro QD	M18-3VNFF150-Q8	M18-3VPFF150-Q8
 FIXED-FIELD	200 mm	2 m	M18-3VNFF200-2M	M18-3VPFF200-2M
		4-pin Euro QD	M18-3VNFF200-Q8	M18-3VPFF200-Q8

For more specifications see page 135.

 Connection options: A model with a QD requires a mating cordset (see page 132).
 For 150 mm cable with a 4-pin M12/Euro-style quick disconnect model, add the suffix "Q5". For example, M18-3VNDL-Q5.

M18-4 Series

Metal Barrel-Mount Sensors



- Chemically robust stainless steel sensors for wash-down applications
- Powerful and bright visible red emitter beam for easy alignment and set-up
- Advanced ASIC technology is resistant to optical and electrical noise source
- Robust 250° adjustment potentiometer on select models
- Cordsets and brackets see page 132

Opposed M18-4

➔ Visible Red LED

Sensing Mode	Range	Connection	Models NPN	Models PNP
<p>OPPOSED</p>	25 m	2 m	M18-4NAEL-2M Emitter	
		4-pin Euro QD	M18-4NAEL-Q8 Emitter	
		2 m	M18-4NAEJ-2M Emitter (Beam inhibit)	
		4-pin Euro QD	M18-4NAEJ-Q8 Emitter (Beam inhibit)	
<p>OPPOSED</p>	25 m	2 m	M18-4NAES-2M Emitter (Adjustment)	
		4-pin Euro QD	M18-4NAES-Q8 Emitter (Adjustment)	
		2 m	M18-4VNRL-2M	M18-4VPRL-2M
		4-pin Euro QD	M18-4VNRL-Q8	M18-4VPRL-Q8
		2 m	M18-4VNRS-2M (Adjustment)	M18-4VPRS-2M (Adjustment)
		4-pin Euro QD	M18-4VNRS-Q8 (Adjustment)	M18-4VPRS-Q8 (Adjustment)

Retro & Polar Retro M18-4

➔ Infrared LED

➔ Visible Red LED

Sensing Mode	Range †	Connection	Models NPN	Models PNP
<p>RETRO</p>	7.5 m	2 m	M18-4VNLV-2M (Adjustment)	M18-4VPLV-2M (Adjustment)
		4-pin Euro QD	M18-4VNLV-Q8 (Adjustment)	M18-4VPLV-Q8 (Adjustment)
<p>POLAR RETRO</p>	2 m	2 m	M18-4VNLP-2M	M18-4VPLP-2M
		4-pin Euro QD	M18-4VNLP-Q8	M18-4VPLP-Q8
		2 m	M18-4VNLPC-2M (Adjustment)	M18-4VPLPC-2M (Adjustment)
		4-pin Euro QD	M18-4VNLPC-Q8 (Adjustment)	M18-4VPLPC-Q8 (Adjustment)

For more specifications see page 135.

➔ Connection options: A model with a QD requires a mating cordset (see page 132).

For 150 mm cable with a 4-pin M12/Euro-style quick disconnect model, add the suffix "Q5". For example, M18-4VNRL-Q5.

† Retroreflective range is specified using one model BRT-84.

Actual sensing range may differ, depending on the efficiency and reflective area of the retroreflector used. See Accessories section for more information.

Diffuse M18-4

 Visible Red LED

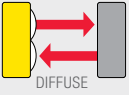
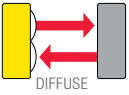
Sensing Mode	Range	Connection	Models NPN	Models PNP
 DIFFUSE	750 mm	2 m	M18-4VNDL-2M (Adjustment)	M18-4VPDL-2M (Adjustment)
		4-pin Euro QD	M18-4VNDL-Q8 (Adjustment)	M18-4VPDL-Q8 (Adjustment)
 DIFFUSE	300 mm	2 m	M18-4VNDS-2M (Adjustment)	M18-4VPDS-2M (Adjustment)
		4-pin Euro QD	M18-4VNDS-Q8 (Adjustment)	M18-4VPDS-Q8 (Adjustment)

Fixed-Field M18-4

 Visible Red LED

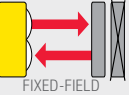
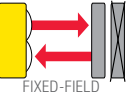
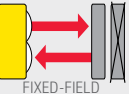
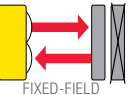
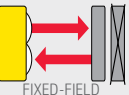
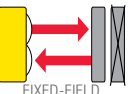
Sensing Mode	Range	Connection	Models NPN	Models PNP
 FIXED-FIELD	30 mm	2 m	M18-4VNFF30-2M	M18-4VPFF30-2M
		4-pin Euro QD	M18-4VNFF30-Q8	M18-4VPFF30-Q8
 FIXED-FIELD	50 mm	2 m	M18-4VNFF50-2M	M18-4VPFF50-2M
		4-pin Euro QD	M18-4VNFF50-Q8	M18-4VPFF50-Q8
 FIXED-FIELD	75 mm	2 m	M18-4VNFF75-2M	M18-4VPFF75-2M
		4-pin Euro QD	M18-4VNFF75-Q8	M18-4VPFF75-Q8
 FIXED-FIELD	100 mm	2 m	M18-4VNFF100-2M	M18-4VPFF100-2M
		4-pin Euro QD	M18-4VNFF100-Q8	M18-4VPFF100-Q8
 FIXED-FIELD	150 mm	2 m	M18-4VNFF150-2M	M18-4VPFF150-2M
		4-pin Euro QD	M18-4VNFF150-Q8	M18-4VPFF150-Q8
 FIXED-FIELD	200 mm	2 m	M18-4VNFF200-2M	M18-4VPFF200-2M
		4-pin Euro QD	M18-4VNFF200-Q8	M18-4VPFF200-Q8

For more specifications see page 135.

 Connection options: A model with a QD requires a mating cordset (see page 132).
 For 150 mm cable with a 4-pin M12/Euro-style quick disconnect model, add the suffix "Q5". For example, M18-3VNDL-Q5.



Euro-Style
Straight connector models listed; for right-angle, add **RA** to the end of the model number (example, **MQDC-406RA**)

4-Pin
MQDC-406
2 m (6.5')
MQDC-415
5 m (15')
MQDC-430
9 m (30')



Micro-Style
Straight connector models listed; for right-angle, add **RA** to the end of the model number (example, **MQDC-306RA**)

4-Pin
MQAC-406
2 m (6.5')
MQAC-415
5 m (15')
MQAC-430
9 m (30')

Reflectors



Additional information is available
See page 790

Apertures



Additional information is available
See page 816

Additional cordset information is available
See page 758



SMB18A



SMBAMS18P

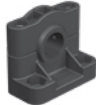

SMB3018SC



SMB18FAM12

Additional bracket information is available
See page 723



S18-2 dc Polarized Retroreflective and Fixed-Field Models
Suffix LP and FF



S18 dc Opposed, Non-polarized Retroreflective and Diffuse Models
Suffix E, R, L and D



S18 ac Opposed, Retroreflective, Polarized Retroreflective, Diffuse and Fixed-Field Models
Suffix E, R, L, LP, D and FF



M18 Opposed, Non-polarized Retroreflective and Diffuse Models
Suffix E, R, L, D and DL





M18-3 Opposed, Retroreflective, Polarized Retroreflective, Fixed-Field and Diffuse Models
Suffix E, R, L, D and DL





M18-4 Opposed, Retroreflective, Polarized Retroreflective, Fixed-Field and Diffuse Models
Suffix E, R, L, D and DL

S18-2 and S18 DC Specifications

Supply Voltage and Current	<p>S18: 10 to 30 V dc (10% max. ripple); Supply current (exclusive of load current): S18-2: 10 to 30 V dc ≤ 55° C; 10 to 24 V dc > 55° C (10% max. ripple); Supply current (exclusive of load current):</p> <p>S18-2: Opposed Emitters: 17 mA S18: Opposed Emitters: 25 mA Opposed Receivers: 8 mA Opposed Receivers: 20 mA Polarized Retroreflective: 16 mA Polarized Retroreflective: 30 mA Diffuse: 16 mA Non-polarized Retroreflective: 25 mA Fixed-Field: 35 mA Diffuse: 25 mA</p>
Supply Protection Circuitry	Protected against reverse polarity and transient voltages
Output Configuration	Solid-state complementary dc switch; NPN (current sinking) or PNP (current sourcing), depending on model S18: The Dark Operate (DO) output may be wired as a normally open marginal signal alarm output, depending upon hookup to the power supply
Output Rating	<p>S18: 150 mA max. (each) in standard hookup. When wired for alarm output, the total load may not exceed 150 mA S18-2: Less than or equal to 100 mA total current through both outputs at less than or at 55 °C Less than or equal to 50 mA total current for ambient temperatures greater than 55 °C OFF-state leakage current: S18-2: less than 50 µA at 30 V dc S18: less than 1 µA at 30 V dc ON-state saturation voltage: S18-2: less than 1.5 V at 10 mA dc; less than 2.75 V at 100 mA dc S18: less than 1 V at 10 mA dc; less than 1.5 V at 150 mA dc</p>
Output Protection Circuitry	Protected against false pulse on power-up and continuous overload or short circuit of outputs
Output Response Time	<p>S18-2: Opposed: 1.5 milliseconds ON, 1.0 milliseconds OFF Retro, Polarized Retroreflective and Diffuse: 1.5 milliseconds ON, 0.75 milliseconds OFF S18: Opposed: 3 milliseconds ON, 1.5 milliseconds OFF Polarized Retroreflective, Non-polarized Retroreflective, Fixed-Field and Diffuse: 3 milliseconds ON/OFF</p>
Delay at Power-up	100 milliseconds; outputs are non-conducting during this time
Repeatability	<p>S18-2: Opposed: 170 microseconds Polarized Retroreflective and Diffuse: 100 microseconds S18: Opposed: 375 microseconds Polarized Retroreflective, Non-polarized Retroreflective, Fixed-Field and Diffuse: 750 microseconds. Repeatability and response are independent of signal strength.</p>
Adjustments	<p>Diffuse (DL), Emitter (ES), Receiver (RS), Polarized Retroreflective (LPC), Retroreflective (LV) models: Single turn sensitivity (gain) adjustment potentiometer Emitter Beam Inhibit (EJ) models: Tie black wire to 10 to 30 V dc for beam inhibit</p>
Indicators	<p>S18-2: Three LED's: Green: Power is ON Green Flashing: Marginal sensing signal Yellow: Pin 4 (black wire) output conducting S18: Two LEDs: Green: Power is ON Green Flashing: Output overloaded Yellow: Light Operate (LO) output is energized</p>
Construction	<p>S18-2 models: ABS housing S18 models: thermoplastic polyester housing Lenses are polycarbonate or acrylic; S18 models come with two jam nuts</p>
Environmental Rating	<p>S18-2: IEC 60529 IP67 S18: Leakproof design rated NEMA 6P, IP67. QD models rated IP69K per DIN 40050-9.</p>
Connections	2 m or 9 m attached cable, or 4-pin Euro-style quick-disconnect fitting. QD cordsets are ordered separately.
Operating Conditions	Temperature: -40° to +70° C Relative humidity: S18: 90% at 50° C (non-condensing) S18-2: 95% @ 50° C (non-condensing)
Vibration and Mechanical Shock	All models meet Mil. Std. 202F requirements. Method 201A (Vibration; frequency 10 to 60 Hz, max., double amplitude 0.06-inch acceleration 10G). Method 213B conditions H&I (Shock: 75G with unit operating; 100G for non-operation)
Certifications	<p>S18-2, S18 models:  S18 models:   ECOLAB® chemical compatibility pending on some models; contact Banner Engineering for details</p>

S18 AC Specifications

Supply Voltage and Current	20 to 250 V ac (50/60 Hz). Average current: 20 mA. Peak current: 200 mA at 20 V ac, 500 mA at 120 V ac, 750 mA at 250 V ac
Supply Protection Circuitry	Protected against transient voltages
Output Configuration	Solid-state ac switch; three-wire hookup; Light Operate (LO) or Dark Operate (DO), depending on model Light Operate: Output conducts when the sensor sees its own (or the emitter's) modulated light Dark Operate: Output conducts when sensor sees dark
Output Rating	300 mA max. (continuous) Fixed-Field: derate 5 mA/° C above +50° C Inrush capability: 1 amp for 20 milliseconds, non-repetitive OFF-state leakage current: less than 100 µA ON-state voltage drop: 3 V at 300 mA ac; 2 V at 15 mA ac
Output Protection Circuitry	Protected against false pulse on power-up
Output Response Time	Opposed: 16 milliseconds ON, 8 milliseconds OFF Polarized Retroreflective, Non-polarized Retroreflective, Fixed-Field and Diffuse: 16 milliseconds ON/OFF
Delay at Power-up	100 milliseconds
Repeatability	Opposed: 2 milliseconds Polarized Retroreflective, Non-polarized Retroreflective, Fixed-Field and Diffuse: 4 milliseconds Repeatability and response are independent of signal strength.
Indicators	Two LEDs: Green: Power ON Yellow: Light sensed Yellow Flashing: Marginal excess gain
Construction	Housings are thermoplastic polyester. Lenses are polycarbonate or acrylic; two jam nuts included.
Environmental Rating	Leakproof design rated NEMA 6P, IP67. QD models rated IP69K per DIN 40050-9.
Connections	2 m or 9 m attached cable, or 4-pin Micro-style quick-disconnect fitting. QD cordsets are ordered separately.
Operating Conditions	Temperature: -40° to +70° C Relative humidity: 90% at 50° C (non-condensing)
Vibration and Mechanical Shock	All models meet Mil. Std. 202F requirements. Method 201A (Vibration; frequency 10 to 60 Hz, max, double amplitude 0.06-inch acceleration 10G). Method 213B conditions H&I (Shock: 75G with unit operating; 100G for non-operation)
Certifications	   ECOLAB® chemical compatibility pending on some models; contact Banner Engineering for details

M18 DC Specifications

Supply Voltage and Current	10 to 30 V dc (10% max. ripple); Supply current (exclusive of load current): Opposed Emitters: 25 mA Opposed Receivers: 20 mA Polarized Retroreflective: 30 mA Non-polarized Retroreflective: 25 mA Fixed-Field: 35 mA Diffuse: 25 mA
Supply Protection Circuitry	Protected against reverse polarity and transient voltages
Output Configuration	Solid-state complementary dc switch; NPN (current sinking) or PNP (current sourcing), depending on model The Dark Operate (DO) output may be wired as a normally open marginal signal alarm output, depending upon hookup to the power supply
Output Rating	150 mA max. (each) in standard hookup. When wired for alarm output, the total load may not exceed 150 mA OFF-state leakage current: less than 1 μ A at 30 V dc ON-state saturation voltage: less than 1 V at 10 mA dc; less than 1.5 V at 150 mA dc
Output Protection Circuitry	Protected against false pulse on power-up and continuous overload or short circuit of outputs
Output Response Time	Opposed: 3 milliseconds ON, 1.5 milliseconds OFF Polarized Retroreflective, Non-polarized Retroreflective, Fixed-Field and Diffuse: 3 milliseconds ON/OFF
Delay at Power-up	100 milliseconds; outputs are non-conducting during this time
Repeatability	Opposed: 375 microseconds Polarized Retroreflective, Non-polarized Retroreflective, Fixed-Field and Diffuse: 750 microseconds. Repeatability and response are independent of signal strength.
Indicators	Two LEDs: Green: Power is ON Yellow: Light Operate (LO) output is energized Green Flashing: Output overloaded Yellow Flashing: Marginal excess gain
Construction	Stainless steel housing Lenses are polycarbonate or acrylic; come with two jam nuts
Environmental Rating	Leakproof design rated NEMA 6P, IP67. QD models rated IP69K per DIN 40050-9.
Connections	2 m or 9 m attached cable, or 4-pin Euro-style quick-disconnect fitting. QD cordsets are ordered separately.
Operating Conditions	Temperature: -40° to +70° C Relative humidity: 90% at 50° C (non-condensing)
Vibration and Mechanical Shock	All models meet Mil. Std. 202F requirements. Method 201A (Vibration; frequency 10 to 60 Hz, max., double amplitude 0.06-inch acceleration 10G). Method 213B conditions H&I (Shock: 75G with unit operating; 100G for non-operation)
Certifications	

S30 Series

Plastic Barrel-Mount Sensors



- Long-range opposed mode
- Features 30 mm plastic threaded barrel
- Available in 10-30 V dc or 20-250 V ac
- Ideal for use in harsh sensing environments
- Cordsets and brackets see page 138

Opposed S30, 10-30 V DC

Infrared LED

Sensing Mode	Range	Connection	Models NPN	Models PNP
 OPPOSED	60 m	2 m 4-Pin Euro QD 2 m 4-Pin Euro QD	S30SN6R S30SN6RQ	S30SP6R S30SP6RQ
			S306E Emitter S306EQ Emitter	

Polar Retro S30, 10-30 V DC

Visible Red LED

Sensing Mode	Range	Connection	Models NPN	Models PNP
 POLAR RETRO	6 m [†]	2 m 4-Pin Euro QD	S30SN6LP S30SN6LPQ	S30SP6LP S30SP6LPQ

Fixed-Field S30, 10-30 V DC

Infrared LED

Sensing Mode	Range	Connection	Models NPN	Models PNP
 FIXED-FIELD	0 - 200 mm Cutoff	2 m	S30SN6FF200	S30SP6FF200
		4-Pin Euro QD	S30SN6FF200Q	S30SP6FF200Q
 FIXED-FIELD	0 - 400 mm Cutoff	2 m	S30SN6FF400	S30SP6FF400
		4-Pin Euro QD	S30SN6FF400Q	S30SP6FF400Q
 FIXED-FIELD	0 - 600 mm Cutoff	2 m	S30SN6FF600	S30SP6FF600
		4-Pin Euro QD	S30SN6FF600Q	S30SP6FF600Q

For more specifications see page 138.

Connection options: A model with a QD requires a mating cordset (see page 138).

For 9 m cable, add suffix W/30 to the 2 m model number (example, S30SP6LP W/30).

[†] Retroreflective range is specified using one model BRT-3 retroreflector.

Actual sensing range may differ, depending on the efficiency and reflective area of the retroreflector used. See Accessories for more information.

Opposed S30, 20-250 V AC



Sensing Mode	Range	Connection	Models Light Operate	Models Dark Operate
<p>OPPOSED</p>	60 m	2 m	S303E Emitter	
		4-Pin Micro QD	S303EQ1 Emitter	
		2 m	S30AW3R	S30RW3R
		4-Pin Micro QD	S30AW3RQ1	S30RW3RQ1

Polar Retro S30, 20-250 V AC



Sensing Mode	Range	Connection	Models Light Operate	Models Dark Operate
<p>POLAR RETRO</p>	6 m [†]	2 m	S30AW3LP	S30RW3LP
		4-Pin Micro QD	S30AW3LPQ1	S30RW3LPQ1

Fixed-Field S30, 20-250 V AC



Sensing Mode	Range	Connection	Models Light Operate	Models Dark Operate
<p>FIXED-FIELD</p>	0 - 200 mm Cutoff	2 m	S30AW3FF200	S30RW3FF200
		4-Pin Micro QD	S30AW3FF200Q1	S30RW3FF200Q1
<p>FIXED-FIELD</p>	0 - 400 mm Cutoff	2 m	S30AW3FF400	S30RW3FF400
		4-Pin Micro QD	S30AW3FF400Q1	S30RW3FF400Q1
<p>FIXED-FIELD</p>	0 - 600 mm Cutoff	2 m	S30AW3FF600	S30RW3FF600
		4-Pin Micro QD	S30AW3FF600Q1	S30RW3FF600Q1

For more specifications see page 139.

Connection options: A model with a QD requires a mating cordset (see page 138).

For 9 m cable, add suffix W/30 to the 2 m model number (example, S30SP6LP W/30).

[†] Retroreflective range is specified using one model BRT-3 retroreflector.
Actual sensing range may differ, depending on the efficiency and reflective area of the retroreflector used. See Accessories for more information.



Euro-Style
Straight connector models listed; for right-angle, add **RA** to the end of the model number (example, **MQDC-406RA**)

4-Pin
MQDC-406
2 m (6.5')
MQDC-415
5 m (15')
MQDC-430
9 m (30')



Micro-Style
Straight connector models listed; for right-angle, add **RA** to the end of the model number (example, **MQDC-306RA**)

4-Pin
MQAC-406
2 m (6.5')
MQAC-415
5 m (15')
MQAC-430
9 m (30')

Additional cordset information is available
See page 758



SMB18A



SMBAMS18P

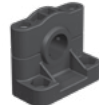

SMB3018SC



SMB18FA..

Additional bracket information is available
See page 724



S30 DC Opposed, Polarized Retroreflective and Fixed-Field Models
Suffix E, R, LP and FF



S30 AC Opposed, Polarized Retroreflective and Fixed-Field Models
Suffix E, R, LP and FF

Reflectors



Apertures



Additional information is available
See page 790

Additional information is available
See page 816

S30 DC Specifications



Supply Voltage and Current	10 to 30 V dc (10% max. ripple); Supply current (exclusive of load current): Opposed Emitters: 25 mA Opposed Receivers: 20 mA Polarized Retroreflective: 30 mA Fixed-Field: 35 mA
Supply Protection Circuitry	Protected against reverse polarity and transient voltages
Output Configuration	Solid-state complementary; choose NPN (current sinking) or PNP (current sourcing) models. The Dark Operate (DO) output may be wired as a normally open marginal signal alarm output, depending upon hookup to the power supply.
Output Rating	150 mA max. (each) in standard hookup; When wired for alarm output, the total load may not exceed 150 mA OFF-state leakage current: less than 1 µA at 30 V dc ON-state saturation voltage: less than 1 V at 10 mA dc; less than 1.5 V at 150 mA dc
Output Protection Circuitry	Protected against false pulse on power-up and continuous overload or short circuit of outputs
Output Response Time	Opposed: 3 milliseconds ON; 1.5 milliseconds OFF Polarized Retroreflective and Fixed-Field: 3 milliseconds ON/OFF
Delay at Power-up	100 milliseconds; outputs are non-conducting during this time
Repeatability	Opposed: 375 microseconds Polarized Retroreflective and Fixed-Field: 750 microseconds Repeatability and response are independent of signal strength
Indicators	Two LEDs: Solid Green: Power ON Flashing Green: output over loaded Solid Yellow: Light Operate (LO) energized Flashing Yellow: marginal excess gain See datasheet for detailed information
Construction	Housings are thermoplastic polyester. Lenses are polycarbonate or acrylic; two jam nuts included.
Environmental Rating	Leakproof design rated NEMA 6P, IP67. QD models rated IP69K per DIN 40050-9.
Connections	2 m or 9 m attached cable, or 4-pin Euro-style quick-disconnect fitting. QD cordsets are ordered separately.
Operating Conditions	Temperature: -40° to +70° C Relative humidity: 90% at 50° C (non-condensing)
Vibration and Mechanical Shock	All models meet Mil. Std. 202F requirements. Method 201A (Vibration; frequency 10 to 60 Hz, max., double amplitude 0.06-inch acceleration 10G). Method 213B conditions H&I (Shock: 75G with unit operating; 100G for non-operation)

Certifications



ECOLAB® chemical compatibility pending on some models; contact Banner Engineering for details

S30 AC Specifications

Supply Voltage and Current	20 to 250 V ac (50/60 Hz). Average current: 20 mA Peak current: 200 mA at 20 V ac, 500 mA at 120 V ac, 750 mA at 250 V ac
Supply Protection Circuitry	Protected against transient voltages
Output Configuration	Solid-state ac switch; three-wire hookup; choose Light Operate (LO) or Dark Operate (DO) models; Light Operate: Output conducts when the sensor sees its own (or the emitter's) modulated light Dark Operate: Output conducts when sensor sees dark
Output Rating	300 mA max. (continuous) Fixed-Field: derate 5 mA/° C above +50° C Inrush capability: 1 amp for 20 milliseconds, non-repetitive OFF-state leakage current: less than 100 µA ON-state voltage drop: 3 V at 300 mA ac; 2 V at 15 mA ac
Output Protection Circuitry	Protected against false pulse on power-up
Output Response Time	Opposed: 16 milliseconds ON; 8 milliseconds OFF Polarized Retroreflective and Fixed-Field: 16 milliseconds ON/OFF
Delay at Power-up	100 milliseconds
Repeatability	Opposed: 2 milliseconds Polarized Retroreflective and Fixed-Field: 4 milliseconds Repeatability and response are independent of signal strength
Indicators	Two LEDs: Solid Green: Power ON Solid Yellow: Light Operate (LO) energized Flashing Yellow: marginal excess gain See datasheet for detailed information
Construction	Housings are thermoplastic polyester. Lenses are polycarbonate or acrylic; two jam nuts included
Environmental Rating	Leakproof design rated NEMA 6P, IP67. QD models rated IP69K per DIN 40050-9
Connections	2 m or 9 m attached cable, or 4-pin Micro-style quick-disconnect fitting QD cordsets are ordered separately.
Operating Conditions	Temperature: -40° to +70° C Relative humidity: 90% at 50° C (non-condensing)
Vibration and Mechanical Shock	All models meet Mil. Std. 202F requirements. Method 201A (Vibration; frequency 10 to 60 Hz, max, double amplitude 0.06-inch acceleration 10G). Method 213B conditions H&I (Shock: 75G with unit operating; 100G for non-operation).
Certifications	   ECOLAB® chemical compatibility pending on some models; contact Banner Engineering for details

SM30 Series

Long-Range, Opposed-Mode Barrel Sensors



- Available with ac or dc supply voltages
- Ideal in equipment washdown environments
- Epoxy-encapsulated
- Sensing range up to 200 m

Opposed SM30 Emitters, 10-30 V DC or 12-240 V AC, Frequency A[†]

Infrared LED

Sensing Mode	Housing	Range	Connection	Output Type	Models
	Plastic	150 m	2 m 3-Pin Mini QD	N/A	SMA30PEL SMA30PELQD
	Stainless Steel	150 m	2 m 3-Pin Mini QD	N/A	SMA30SEL SMA30SELQD

Opposed SM30 Receivers, 10-30 V DC Frequency A[†]

Infrared LED

Sensing Mode	Housing	Range	Connection	Output Type	Models
	Plastic	150 m	2 m 4-Pin Mini QD	Bi-Modal™ NPN or PNP	SM30PRL SM30PRLQD
	Stainless Steel	150 m	2 m 4-Pin Mini QD	Bi-Modal™ NPN or PNP	SM30SRL SM30SRLQD

Opposed SM30 Receivers, 24-240 V AC, Frequency A[†]

Infrared LED

Sensing Mode	Housing	Range	Connection	Output Type	Models
	Plastic	150 m	2 m	LO	SM2A30PRL
			3-Pin Mini QD		SM2A30PRLQD
	Stainless Steel	150 m	2 m	LO	SM2A30SRL
			3-Pin Mini QD		SM2A30SRLQD
Plastic	150 m	2 m	DO	SM2A30PRLNC	
		3-Pin Mini QD		SM2A30PRLNCQD	
Stainless Steel	150 m	2 m	DO	SM2A30SRLNC	
		3-Pin Mini QD		SM2A30SRLNCQD	

Connection options: A model with a QD requires a mating cordset.
 For 9 m cable, add suffix W/30 to the 2 m model number (example, SMA30PEL W/30).
[†] Modulation frequency "A" is standard; frequencies "B" and "C" are also available to minimize optical crosstalk potential between adjacent pairs and are specified by adding "B" or "C" at the end of the standard model number (example, SMA30PELB or SMA30PELC).



Additional cordset information is available
 See page 758



Additional bracket information is available
 See page 724



Opposed Models—All Frequencies
 Suffix E and R
 (Metal Housing Shown)



SM30 Specifications



Supply Voltage and Current	Emitters: 12 to 240 V ac (50/60 Hz) or 10 to 30 V dc (10% max. ripple) at 20 mA DC Receivers: 10 to 30 V dc (10% max. ripple) at 10 mA max, exclusive of load AC Receivers: 24 to 240 V ac (50/60 Hz)
Supply Protection Circuitry	Protected against reverse polarity and transient voltages
Output Configuration	DC Receivers: Bi-Modal™ output (PNP sourcing or NPN sinking). Selection of sourcing or sinking configuration depends upon receiver's power supply hookup polarity. Once wired, the unit performs as a solid-state switch. AC Receivers: Solid-state switch offer Light Operate (LO) or Dark Operate (DO) by model
Output Rating	DC Receivers: 250 mA continuous Output saturation voltage: (PNP & NPN configuration) less than 1 volt at 10 mA; less than 2 volts at 250 mA OFF-state leakage current: less than 10 µA AC Receivers: Max. steady-state load capability is 500 mA Inrush capability: 10 amps for 1 second (non-repeating) OFF-state leakage: current less than 1.7 mA rms ON-state voltage drop: less than 3.5 volts rms across a 500 mA load; less than 5 volts rms across a 15 mA load
Output Protection Circuitry	Outputs of dc receivers are short circuit protected
Output Response Time	10 milliseconds ON/OFF
Repeatability	"A" frequency units: 1 millisecond "B" frequency units: 1.5 milliseconds "C" frequency units: 2.3 milliseconds
Indicators	Internal Red LED, visible through the lens or from side of the sensor. Emitters: Red "Power ON" indicator LED DC Receivers: Lights whenever receiver sees its modulated light source AC Receivers: Lights whenever receiver's output is conducting
Construction	Fully epoxy-encapsulated tubular threaded housing, positive sealed at both ends, quad-ring sealed acrylic lens Plastic models: 30 mm diameter thermoplastic polyester housing and jam nuts Stainless Steel models: 30 mm diameter 303 stainless steel housing and jam nuts
Environmental Rating	Exceeds NEMA 6P; IEC IP67 standards
Connections	PVC-jacketed 2 m or 9 m cables or Mini-style quick-disconnect (QD) fitting are available. QD cordsets are ordered separately.
Operating Conditions	Temperature: -40° to +70° C Relative humidity: 90% at 50° C (non-condensing)





Slot & Area

Slot sensors, also known as fork sensors, provide easy and reliable opposed-mode sensing of objects as small as 0.3 mm. Slot sensors are offered in a wide variety of sizes to meet your application needs.

Series	Description	Max Sensing Range	Dimensions H x W x D	Protection Rating	Housing Material	Power Supply
	<p>SLM Easy to mount, focus-beamed sensors with powerful optics. Page 144</p>	<p>Opposed: 220 mm</p>	<p>Varies by model</p>	<p>IP67; NEMA 6</p>	<p>Die-cast zinc</p>	<p>10 to 30 V dc</p>
	<p>SL30 & SL10 A fixed-distance slot sensor with a slot that offers high speed sensing with expert push-button TEACH options. Page 146</p>	<p>Opposed: 30 mm</p>	<p>72 x 52 x 18.8 mm</p>	<p>IP67; NEMA 6</p>	<p>ABS/polycarbonate</p>	<p>10 to 30 V dc</p>
	<p>LX Part-Sensing Arrays provides wide area detection used for detecting small parts on conveyors, part ejection verification and leading edge detection. Page 148</p>	<p>Opposed: 2 m</p>	<p>Varies by model</p>	<p>IP65</p>	<p>Aluminum housing, die-cast zinc with black e-coated painted endcaps</p>	<p>10 to 30 V dc</p>

SLM Series

Rugged, Nickel-Plated, Fixed-Distance Slot Sensors



- Easy to mount, focus-beamed sensors with powerful optics.
- Powerful optics for detecting between sheets of plastic
- Requires no alignment, with easy and economical mounting that uses molded in-beam guides to simplify beam placement
- Rugged metal housing rated to IP67

SLM Nickel-Plated

Visible Red LED

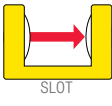
Sensing Mode	Slot Width/ Depth	Width (W)	Depth (D)	Connection	Response	Models NPN	Models PNP
	10 mm/ 60.8 mm	42 mm	80 mm	2 m 4-Pin Euro Pigtail QD 3-Pin Pico QD	500 μ s	SLM10B6 (Bipolar NPN/PNP) SLM10B6QPMA (Bipolar NPN/PNP) SLM10N6Q	SLM10P6Q
	20 mm/ 60.8 mm	52 mm	80 mm	2 m 4-Pin Euro Pigtail QD 3-Pin Pico QD	500 μ s	SLM20B6 (Bipolar NPN/PNP) SLM20B6QPMA (Bipolar NPN/PNP) SLM20N6Q	SLM20P6Q
	30 mm/ 60.8 mm	62 mm	80 mm	2 m 4-Pin Euro Pigtail QD 3-Pin Pico QD	500 μ s	SLM30B6 (Bipolar NPN/PNP) SLM30B6QPMA (Bipolar NPN/PNP) SLM30N6Q	SLM30P6Q
	50 mm/ 60.8 mm	82 mm	80 mm	2 m 4-Pin Euro Pigtail QD 3-Pin Pico QD	500 μ s	SLM50B6 (Bipolar NPN/PNP) SLM50B6QPMA (Bipolar NPN/PNP) SLM50N6Q	SLM50P6Q
	80 mm/ 60.8 mm	112 mm	80 mm	2 m 4-Pin Euro Pigtail QD 3-Pin Pico QD	500 μ s	SLM80B6 (Bipolar NPN/PNP) SLM80B6QPMA (Bipolar NPN/PNP) SLM80N6Q	SLM80P6Q
	120 mm/ 120.7 mm	152 mm	140 mm	2 m 4-Pin Euro Pigtail QD 3-Pin Pico QD	500 μ s	SLM120B6 (Bipolar NPN/PNP) SLM120B6QPMA (Bipolar NPN/PNP) SLM120N6Q	SLM120P6Q
	180 mm/ 120.7 mm	202 mm	140 mm	2 m 4-Pin Euro Pigtail QD 3-Pin Pico QD	500 μ s	SLM180B6 (Bipolar NPN/PNP) SLM180B6QPMA (Bipolar NPN/PNP) SLM180N6Q	SLM180P6Q
	220 mm/ 120.7 mm	252 mm	140 mm	2 m 4-Pin Euro Pigtail QD 3-Pin Pico QD	500 μ s	SLM220B6 (Bipolar NPN/PNP) SLM220B6QPMA (Bipolar NPN/PNP) SLM220N6Q	SLM220P6Q

Connection options: A model with a QD requires a mating cordset

For 9 m cable, add suffix W/30 to the 2 m model number (example, SLM10B6 W/30).



Euro QD
(for ..Q8 or ..Q5 models)
Straight connector models listed; for right-angle, add **RA** to the end of the model number (example, **MQDC-406RA**)

4-Pin
MQDC-406
2 m (6')
MQDC-415
5 m (15')
MQDC-430
9 m (30')



Pico QD (for Q models)
Straight connector models listed; for right-angle, **W** replaces **G** in the model number.
(example, **PKW3M-5**)
*There are no PKW3M-7, or PKW3M-10 models available

3-Pin
PKG3M-2
2 m (6.5')
PKG3M-5
5 m (15')
PKG3M-7
7 m (23')
PKG3M-9
9 m (30')
PKG3M-10
10 m

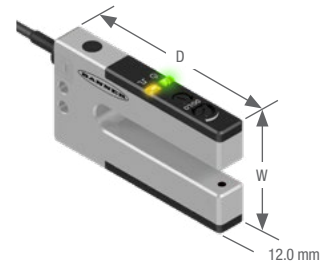

Additional cordset information is available
See page 758

SLM Specifications

Slot Opening	10, 20, 30, 50, 80, 120, 180 or 220 mm (depending on model); beam is 5 mm from outer edge							
Supply Voltage and Current	10 to 30 V dc (10% ripple) @ less than 25 mA, exclusive of load							
Supply Protection Circuitry	Protected against reverse polarity and transient voltages							
Output Configuration	Cabled and Euro-style QD models: Bipolar: One current sourcing (PNP) and one current sinking (NPN) Pico-style QD models: Current sourcing (PNP) or current sinking (NPN), depending on model							
Output Rating	100 mA with short circuit protection OFF-state leakage current: less than 10 µA sourcing; less than 200 µA sinking ON-state saturation voltage: NPN: 1.6 V @ 100 mA PNP: 2.0 V @ 100 mA							
Output Protection Circuitry	Protected against output short-circuit and false pulse on power up. 100 milliseconds max. delay at power up; outputs do not conduct during this time.							
Minimum Object Detection* at Max. Gain	SLM10...	SLM20...	SLM30...	SLM50...	SLM80...	SLM120...	SLM180...	SLM220...
	1.00 mm	1.25 mm	1.50 mm	1.65 mm	1.80 mm	1.80 mm	1.80 mm	2.40 mm
Minimum Object Detection* at 2X Excess Gain	0.30 mm	0.30 mm	0.40 mm	0.60 mm	0.75 mm	0.90 mm	0.90 mm	1.00 mm
Hysteresis**	0.10 mm	0.10 mm	0.10 mm	0.10 mm	0.20 mm	0.20 mm	0.20 mm	0.20 mm
Repeatability†	0.02 mm	0.02 mm	0.02 mm	0.04 mm	0.06 mm	0.08 mm	0.08 mm	0.08 mm
Output Response Time	500 microseconds							
Repeatability	95 microseconds							
Adjustments	1-turn potentiometer Sensitivity adjustment Light Operate / Dark Operate Selection switch							
Indicators	Two LED Indicators: Solid Green: Power ON Flashing Green: output short circuit Solid Yellow: Output activated See datasheet for detailed information							
Construction	Housing: Die-cast zinc Endcaps: ABS Optic windows: Acrylic							
Environmental Rating	IEC IP67; NEMA 6							
Connections	Cabled models: 2 m or 9 m 4-conductor, PVC-jacketed cable Pico-style QD models: 3-pin, threaded Euro-style QD models: 4-pin, threaded 150 mm pigtail with polyurethane (PUR) cable							
Operating Conditions	Temperature: -20° to +60° C Relative humidity: 95% @ 55° C (non-condensing)							
Certifications								

* **Minimum Object Detection:** Smallest diameter rod that can be detected when passed slowly through sensing beam.

NOTE: Minimum object detection is measured midway between the emitter and receiver. For best results, objects to be detected should be placed in the midway position when possible. The minimum object detection size may increase if the object is very close to the receiver side.

** **Hysteresis:** Distance an object must move to toggle between output OFF and output ON conditions.

† **Repeatability:** Variation in switching distance for a standard target at controlled sensing conditions.

SL30 Series

Fixed-Distance Slot Sensors



- Uses molded in-beam guides to simplify beam placement
- Provides easy-to-use self-contained opposed-mode sensor pair in rugged U-shaped housing
- Features manual sensitivity adjustment or easy push-button TEACH-mode setup, depending on model
- Cordsets and brackets see page 148

SL30

➔ Visible Red LED

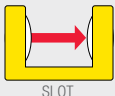
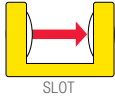
Sensing Mode	Slot Width	Connection	Output Type	Response	Repeatability	Models
	30 mm	2 m 5-Pin Euro QD	Bipolar NPN/PNP	1 ms	250 μ s	SL30VB6V SL30VB6VQ
	30 mm	2 m 5-Pin Euro QD	Bipolar NPN/PNP	300 μ s	75 μ s	SL30VB6VY SL30VB6VYQ

SLO30

➔ Infrared LED

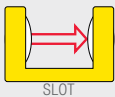
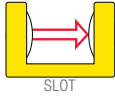
Sensing Mode	Slot Width	Connection	Output Type	Response	Repeatability	Models
	30 mm	2 m 5-Pin Euro QD	Bipolar NPN/PNP	1 ms	250 μ s	SLO30VB6 SLO30VB6Q
	30 mm	2 m 5-Pin Euro QD	Bipolar NPN/PNP	300 μ s	75 μ s	SLO30VB6Y SLO30VB6YQ

SLE30 Expert™

➔ Visible Red LED

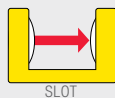
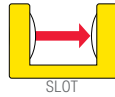
Sensing Mode	Slot Width	Connection	Output Type	Response	Repeatability	Models
	30 mm	2 m 5-Pin Euro QD	Bipolar NPN/PNP	500 μ s	100 μ s	SLE30B6V SLE30B6VQ
	30 mm	2 m 5-Pin Euro QD	Bipolar NPN/PNP	150 μ s	75 μ s	SLE30B6VY SLE30B6VYQ

For more specifications see page 148.

 Connection options: A model with a QD requires a mating cordset (see page 148).

For 9 m cable, add suffix W/30 to the 2 m model number (example, SL30VB6V W/30).

SL10 Series

Fixed-Distance Slot Sensors



- Uses molded in-beam guides to simplify beam placement
- Provides easy-to-use self-contained opposed-mode sensor pair
- Features manual sensitivity adjustment or easy push-button TEACH-mode setup, depending on model
- Cordsets and brackets see page 148

SL10

➔ Visible Red LED

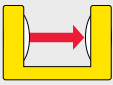
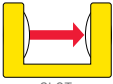
Sensing Mode	Slot Width	Connection	Output Type	Response	Repeatability	Models
	10 mm	2 m 5-Pin Euro QD	Bipolar NPN/PNP	1 ms	250 μ s	SL10VB6V SL10VB6VQ
	10 mm	2 m 5-Pin Euro QD	Bipolar NPN/PNP	300 μ s	75 μ s	SL10VB6VY SL10VB6VYQ

SLE10 Expert™

➔ Visible Red LED

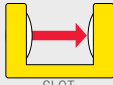
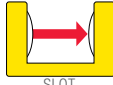
Sensing Mode	Slot Width	Connection	Output Type	Response	Repeatability	Models
	10 mm	2 m 5-Pin Euro QD	Bipolar NPN/PNP	500 μ s	100 μ s	SLE10B6V SLE10B6VQ
	10 mm	2 m 5-Pin Euro QD	Bipolar NPN/PNP	150 μ s	75 μ s	SLE10B6VY SLE10B6VYQ

For more specifications see page 148.

 Connection options: A model with a QD requires a mating cordset (see page 148).

For 9 m cable, add suffix W/30 to the 2 m model number (example, SL10VB6V W/30).



5-Pin
MQDC1-501.5
 0.5 m (1.6')
MQDC1-506
 2 m (6.5')
MQDC1-515
 5 m (15')
MQDC1-530
 9 m (30')

Euro-Style
 Straight connector models listed;
 for right-angle, add **RA** to the end
 of the model number (example,
MQDC1-506RA)



SMBSL
 12-ga. stainless steel

Additional cordset information is available
 See page 758

Additional bracket information is available
 See page 724

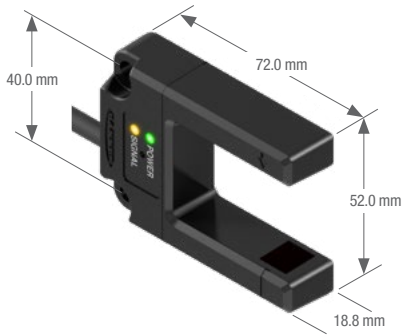

SL30, SLO30 and SLE30 Models

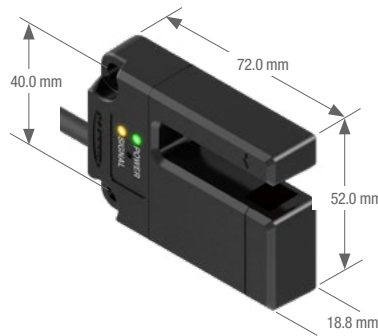

SL10 and SLE10 Models

SL30, SL10 and SLO30 Specifications

Supply Voltage and Current	10 to 30 V dc, 30 mA
Supply Protection Circuitry	Protected against reverse polarity and transient voltages
Output Configuration	Bipolar: One current sinking (NPN) and one current sourcing (PNP) open-collector transistor
Output Rating	150 mA, each output
Output Protection Circuitry	Protected against false pulse on power-up and short-circuit of outputs
Output Response Time	1 millisecond or 300 microseconds, depending on model
Repeatability	250 microseconds or 75 microseconds, depending on model
Adjustments	SL30 and SL10: 4-turn clutched potentiometer sensitivity adjustment SLO30: None
Indicators	Green: Power ON/OFF indicator Yellow: Signal condition indicator
Construction	Housing: ABS/polycarbonate Lenses: Acrylic
Environmental Rating	IP67; NEMA 6
Connections	2 m or 9 m 5-conductor PVC-jacketed attached cable, or 5-pin Euro-style quick-disconnect (QD) fitting. QD cordsets are ordered separately.
Operating Conditions	Temperature: -40° to +70° C Relative humidity: 90% @ 50° C (non-condensing)
Certifications	

SLE30 and SLE10 *Expert™* Specifications

Supply Voltage and Current	10 to 30 V dc (10% max. ripple) at less than 45 mA, exclusive of load
Supply Protection Circuitry	Protected against reverse polarity and transient voltages
Output Configuration	Bipolar: One current sourcing (PNP) and one current sinking (NPN) open-collector transistor
Output Rating	150 mA max. each output at 25° C, derated to 100 mA at 70° C (derate ≈1 mA per ° C) OFF-state leakage current: less than 5 µA @ 30 V dc ON-state saturation current: less than 1 V @ 10 mA; less than 1.5 V @ 150 mA
Output Protection Circuitry	Protected against false pulse on power-up and continuous overload or short-circuit of outputs
Output Response Time	Sensors will respond to either a "light" or a "dark" signal of 500 microseconds (or 150 microseconds, depending on model) or longer duration, 1 kHz max
Delay at Power-up	1 second; outputs are non-conducting during this time
Repeatability	100 microseconds or 75 microseconds, depending on model
Adjustments	Pushbutton TEACH-mode sensitivity setting; remote TEACH-mode input
Indicators	Two LEDs: Yellow and Bicolor Green/Red Green (RUN Mode): ON when power is applied Flashes when received light level approaches the switching threshold Red (TEACH Mode): OFF when no signal is received. Pulses to indicate signal strength (received light level). Rate is proportional to signal strength (the stronger the signal, the faster the pulse rate). This is a function of Banner's Alignment Indicating Device (AID™). Alternating Red/Green: Microprocessor memory error Flashing Yellow (Static TEACH): ON to indicate sensor is ready to learn output ON condition OFF to indicate sensor is ready to learn output OFF condition Yellow (Dynamic TEACH): Pulses at 0.5 Hz when ready to sample ON to indicate Dynamic TEACH sampling OFF to indicate sampling was accepted Yellow (RUN Mode): ON when outputs are conducting
Construction	Housing: ABS/polycarbonate Lenses: Acrylic
Environmental Rating	IEC IP67; NEMA 6
Connections	PVC-jacketed 5-conductor 2 m or 9 m unterminated cable, or 5-pin Euro-style quick-disconnect (QD) fitting. QD cordsets are ordered separately.
Operating Conditions	Temperature: -20° to +70° C Relative humidity: 90% at 50° C (non-condensing)
Application Notes	The first condition presented during TEACH mode becomes the output ON condition
Certifications	

LX

High-Speed Part-Sensing Array

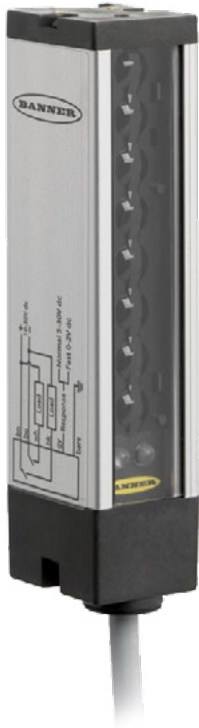

- Detects objects as small as 5.6 mm and extremely flat objects passing anywhere through the screen
- Responds in 0.8 to 6.5 milliseconds, faster than comparable products even at the slowest speed
- Features rugged silver anodized housing rated to IP65
- Uses integrated T-slot mounting channel for unique mounting flexibility

LX Light Screens Short-Range (75-200 mm)

Sensing Array Length	Connection	Output Type	Min object detection size: 5.6 mm dia.	
			Emitters	Receivers
67 mm	2 m	Bipolar NPN/PNP	LX3ESR	LX3RSR
143 mm	2 m	Bipolar NPN/PNP	LX6ESR	LX6RSR
295 mm	2 m	Bipolar NPN/PNP	LX12ESR	LX12RSR

LX Light Screens Standard Range (150 mm-2 m)

Sensing Array Length	Connection	Output Type	Min object detection size: 9.5 mm dia.	
			Emitters	Receivers
67 mm	2 m	Bipolar NPN/PNP	LX3E	LX3R
143 mm	2 m	Bipolar NPN/PNP	LX6E	LX6R
218 mm	2 m	Bipolar NPN/PNP	LX9E	LX9R
295 mm	2 m	Bipolar NPN/PNP	LX12E	LX12R
371 mm	2 m	Bipolar NPN/PNP	LX15E	LX15R
447 mm	2 m	Bipolar NPN/PNP	LX18E	LX18R
523 mm	2 m	Bipolar NPN/PNP	LX21E	LX21R
599 mm	2 m	Bipolar NPN/PNP	LX24E	LX24R

 Connection options: A model with a QD requires a mating cordset.
 For 5-pin 150 mm Euro-style Pigtail QD, add suffix **Q** to the 2 m model number (example, LX3ESRQ).

Euro-Style
 Straight connector models listed; for right-angle, add **RA** to the end of the model number (example, MQDC1-506RA)



5-Pin
 MQDEC2-506
 2 m (6.5')
 MQDEC2-515
 5 m (15')
 MQDEC2-530
 9 m (30')



SMBLX



SMBLXR

Additional cordset information is available
 See page 758

Additional bracket information is available
 See page 724



Models	Length (L)
LX3	113.4 mm
LX6	189.6 mm
LX9	265.8 mm
LX12	342.0 mm
LX15	418.2 mm
LX18	494.4 mm
LX21	570.6 mm
LX24	646.8 mm

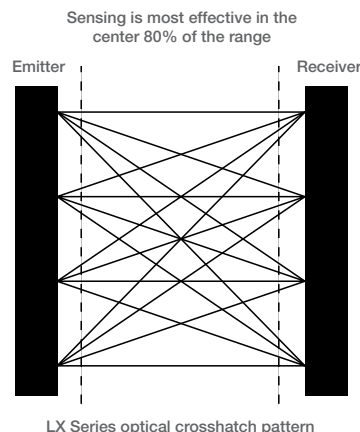

LX Specifications

Sensing Range	<table border="0"> <tr> <td></td> <td>Normal (see hookups)</td> <td>Reduced</td> </tr> <tr> <td>Short-range models:</td> <td>100 to 200 mm</td> <td>75 to 150 mm</td> </tr> <tr> <td>Standard-range models:</td> <td>300 mm to 2 m</td> <td>150 to 600 mm</td> </tr> </table>		Normal (see hookups)	Reduced	Short-range models:	100 to 200 mm	75 to 150 mm	Standard-range models:	300 mm to 2 m	150 to 600 mm
	Normal (see hookups)	Reduced								
Short-range models:	100 to 200 mm	75 to 150 mm								
Standard-range models:	300 mm to 2 m	150 to 600 mm								
Supply Voltage and Current	10 to 30 V dc (10% max. ripple) at less than 1 watt each for emitter and receiver (exclusive of load)									
Supply Protection Circuitry	Protected against reverse polarity and transient voltages									
Output Configuration	Bipolar: One current sourcing (PNP) and one current sinking (NPN) open-collector transistor									
Output Rating	125 mA max. each output OFF-state leakage current: less than 5 μ A Output saturation voltage (PNP output): less than 1 volt at 10 mA and less than 1.5 volts at 100 mA Output saturation voltage (NPN output): less than 0.5 volts at 10 mA and less than 0.6 volts at 100 mA									
Output Protection Circuitry	Protected against false pulse on power-up and continuous overload or short circuit of outputs									
Output Response Time	LX3: 0.8 milliseconds ON-time; 6 milliseconds OFF-time (5 milliseconds OFF-delay) LX6: 1.6 milliseconds ON-time; 7 milliseconds OFF-time (5 milliseconds OFF-delay) LX9: 2.4 milliseconds ON-time; 7.5 milliseconds OFF-time (5 milliseconds OFF-delay) LX12: 3.2 milliseconds ON-time; 8.5 milliseconds OFF-time (5 milliseconds OFF-delay) LX15: 4.0 milliseconds ON-time; 9 milliseconds OFF-time (5 milliseconds OFF-delay) LX18: 4.8 milliseconds ON-time; 10 milliseconds OFF-time (5 milliseconds OFF-delay) LX21: 5.6 milliseconds ON-time; 11 milliseconds OFF-time (5 milliseconds OFF-delay) LX24: 6.4 milliseconds ON-time; 11.5 milliseconds OFF-time (5 milliseconds OFF-delay)									
Minimum Object Detection Size	Smallest diameter rod that can be detected in sensing range: 5.6 mm (short-range) or 9.5 mm (standard-range), depending on model									
Indicators	<table border="0"> <tr> <td>Emitter:</td> <td>LED1 (Green) ON: Power ON, good sensor OFF: Reduced Range</td> <td>LED2 (Red) ON: Reduced range OFF: Normal range Flashing: Emitter hardware failure</td> </tr> <tr> <td>Receiver:</td> <td>LED1 (Yellow) ON: Output conducting OFF: Output not conducting</td> <td>LED2 (Bicolor Green/Red) Green: Normal range Red: Reduced range Flashing Red: Receiver hardware failure</td> </tr> </table>	Emitter:	LED1 (Green) ON: Power ON, good sensor OFF: Reduced Range	LED2 (Red) ON: Reduced range OFF: Normal range Flashing: Emitter hardware failure	Receiver:	LED1 (Yellow) ON: Output conducting OFF: Output not conducting	LED2 (Bicolor Green/Red) Green: Normal range Red: Reduced range Flashing Red: Receiver hardware failure			
Emitter:	LED1 (Green) ON: Power ON, good sensor OFF: Reduced Range	LED2 (Red) ON: Reduced range OFF: Normal range Flashing: Emitter hardware failure								
Receiver:	LED1 (Yellow) ON: Output conducting OFF: Output not conducting	LED2 (Bicolor Green/Red) Green: Normal range Red: Reduced range Flashing Red: Receiver hardware failure								
Construction	Aluminum housing, die-cast zinc with black e-coated painted encaps, acrylic lens window									
Environmental Rating	IEC IP65									
Connections	2 m 5-conductor (with drain) PVC-jacketed cable or 150 mm pigtail with 5-pin Euro-style quick-disconnect fitting, depending on model. Cordsets are ordered separately.									
Operating Conditions	Temperature: -20° to +70° C Relative humidity: 90% at 50° C (non-condensing)									
Application Notes	<ol style="list-style-type: none"> The best sensing resolution occurs within the center 80% of the sensing range Low-profile packages can be reliably detected Outputs are active while the light screen is interrupted For reliable detection, successive parts must be spaced up to the total of ON-time plus OFF-time apart. (i.e., 12 milliseconds for the LX12) 									

Certifications









Miniature

Miniature photoelectric sensors are extremely compact, conveniently fitting into limited spaces with barrel and right angle housings.

Sensors have high-power performance for close range detection. Six sensing modes are available with an opposed mode sensing range up to 3 meters.

Series	Description	Max Sensing Range	Dimensions H x W x D	Protection Rating	Housing Material	Power Supply
	VSM Series Heavy-duty metal sensors that are compact and ideal for use in confined areas. Page 154	Opposed: 250 mm Diffuse: 200 mm	Varies by model	IP67; NEMA 6P	Stainless steel	10 to 30 V dc
	VS1 Small, high performance sensor can easily be embedded into the application. Page 156	Convergent: 15 mm	25.7 x 8.3 x 11.6 mm	IP54, NEMA3	ABS/ polycarbonate	10 to 30 V dc
	VS2 Ultra-thin VS2 miniature sensors are suited to work well in confined areas while providing high performance. Page 158	Opposed: 3 m Convergent: 30 mm	25.1 x 12 x 4.3 mm	IP67; NEMA 6P	ABS	10 to 30 V dc
	VS3 Provides coaxial optics for close-range retro detection of the sensor. Page 160	Coaxial Retro: 250 mm Coaxial Polar Retro: 250 mm	25.4 x 9 x 15.6 mm	IP67; NEMA 6P	ABS	10 to 30 V dc

OTHER AVAILABLE MODELS



Q12 page 66

VSM Series

Self-Contained Metal Sensors



- Heavy-duty, compact, metal sensors that are ideal for use in confined areas.
- Sapphire lens
- Tough 300 series stainless steel body withstands a wide variety of chemicals and cutting fluids
- Smooth barrel models are ideal for hygienic applications that require frequent cleaning
- Advanced optical design provides high performance with repeatable sensing

VSMQ (Flat-Pack, Side-Looker)

Infrared LED

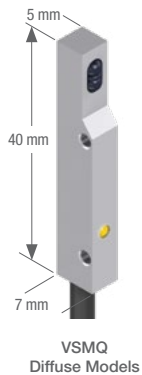

Sensing Mode	Range	Connection	Output Type	Models NPN	Models PNP
DIFFUSE	20-50 mm	2 m	LO	VSMQAN6CV20	VSMQAP6CV20
DIFFUSE	50-140 mm	2 m	LO	VSMQAN6CV50	VSMQAP6CV50
DIFFUSE	90-200 mm	2 m	LO	VSMQAN6CV90	VSMQAP6CV90

VSM4 (4 mm Smooth Barrel)

Infrared LED

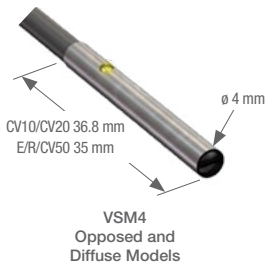

Sensing Mode	Range	Connection	Output Type	Models NPN	Models PNP
OPPOSED	250 mm	2 m	—	VSM46E Emitter	
	250 mm	3-Pin Pico QD	—	VSM46EQ7 Emitter	
OPPOSED	250 mm	2 m	DO	VSM4RN6R	VSM4RP6R
	250 mm	3-Pin Pico QD	DO	VSM4RN6RQ7	VSM4RP6RQ7
DIFFUSE	10-30 mm	2 m	LO	VSM4AN6CV10	VSM4AP6CV10
	10-30 mm	3-Pin Pico QD	LO	VSM4AN6CV10Q7	VSM4AP6CV10Q7
DIFFUSE	20-50 mm	2 m	LO	VSM4AN6CV20	VSM4AP6CV20
	20-50 mm	3-Pin Pico QD	LO	VSM4AN6CV20Q7	VSM4AP6CV20Q7
DIFFUSE	50-140 mm	2 m	LO	VSM4AN6CV50	VSM4AP6CV50
	50-140 mm	3-Pin Pico QD	LO	VSM4AN6CV50Q7	VSM4AP6CV50Q7

Connection options: A model with a QD requires a mating cordset.

VSM5 (5 mm Threaded Barrel)

 Infrared LED

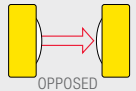
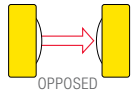
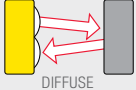
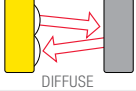
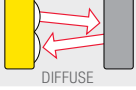
Sensing Mode	Range	Connection	Output Type	Models NPN	Models PNP
 OPPOSED	250 mm	2 m 3-Pin Pico QD	—	VSM56E Emitter VSM56EQ7 Emitter	
 OPPOSED	250 mm	2 m 3-Pin Pico QD	DO	VSM5RN6R VSM5RN6RQ7	VSM5RP6R VSM5RP6RQ7
 DIFFUSE	10-30 mm	2 m 3-Pin Pico QD	LO	VSM5AN6CV10 VSM5AN6CV10Q7	VSM5AP6CV10 VSM5AP6CV10Q7
 DIFFUSE	20-50 mm	2 m 3-Pin Pico QD	LO	VSM5AN6CV20 VSM5AN6CV20Q7	VSM5AP6CV20 VSM5AP6CV20Q7
 DIFFUSE	50-140 mm	2 m 3-Pin Pico QD	LO	VSM5AN6CV50 VSM5AN6CV50Q7	VSM5AP6CV50 VSM5AP6CV50Q7



 Connection options: A model with a QD requires a mating cordset.



3-Pin
PKG3M-2
 2 m (6')
PKG3M-5
 5 m (15')
PKG3M-9
 9 m (30')



SMBVSM4

Pico QD (for Q models)
 Straight connector models listed;
 for right-angle, **W** replaces **G** in
 the model number.
 (example, **PKW3M-2**)

Additional cordsett information is available
 See page 758

Additional bracket information is available
 See page 722

VSM Specifications

Supply Voltage and Current	10 to 30 V dc (10% max. ripple)
Supply Protection Circuitry	Protected against reverse polarity and transient voltages
Output Configuration	Single-output: 1 NPN or 1 PNP, Light Operate (LO) or Dark Operate (DO), depending on model
Output Rating	100 mA max. OFF-state leakage current: less than 1 μ A ON-state saturation voltage: less than 2 V @ 100 mA
Output Protection Circuitry	Protected against false pulse on power-up and continuous overload or short circuit of outputs Overload trip point \geq 100 mA
Response Time	2.5 milliseconds
Delay at Power-up	20 milliseconds
Repeatability	1 millisecond
Indicators	Yellow LED: light sensed
Construction	300 series stainless steel with PVC cable CV10 & CV20: sapphire lens CV50 & Opposed: Glass lens
Environmental Rating	IP67
Connections	2 m PVC-jacketed cable or 3-pin Pico-style integral QD (Q7), depending on model. QD cordsets ordered separately.
Operating Conditions	Operating temperature: 0° to +55° C

Certification



VS1 Series

Miniature Self-Contained Sensors



- Small housing for powerful sensing performance in confined areas
- Available with 10 or 15 mm focal length
- Reliable sensing without adjustments

Convergent VS1

➔ Red LED ➔ Infrared LED

Sensing Mode	Range	Connection	Output Type	Models NPN	Models PNP
 CONVERGENT	10 mm focus	2 m	LO	VS1AN5CV10	VS1AP5CV10
		3-Pin Pico Pigtail QD		VS1AN5CV10Q	VS1AP5CV10Q
		2 m	DO	VS1RN5CV10	VS1RP5CV10
		3-Pin Pico Pigtail QD		VS1RN5CV10Q	VS1RP5CV10Q
 CONVERGENT	15 mm focus	2 m	LO	VS1AN5CV20	VS1AP5CV20
		3-Pin Pico Pigtail QD		VS1AN5CV20Q	VS1AP5CV20Q
		2 m	DO	VS1RN5CV20	VS1RP5CV20
		3-Pin Pico Pigtail QD		VS1RN5CV20Q	VS1RP5CV20Q
 CONVERGENT	10 mm focus	2 m	LO	VS1AN5C10	VS1AP5C10
		3-Pin Pico Pigtail QD		VS1AN5C10Q	VS1AP5C10Q
		2 m	DO	VS1RN5C10	VS1RP5C10
		3-Pin Pico Pigtail QD		VS1RN5C10Q	VS1RP5C10Q
 CONVERGENT	15 mm focus	2 m	LO	VS1AN5C20	VS1AP5C20
		3-Pin Pico Pigtail QD		VS1AN5C20Q	VS1AP5C20Q
		2 m	DO	VS1RN5C20	VS1RP5C20
		3-Pin Pico Pigtail QD		VS1RN5C20Q	VS1RP5C20Q

Connection options: A model with a QD requires a mating cordset.
 For 9 m cable, add suffix W/30 to the 2 m model number (example, VS1AN5CV10 W/30).



Pico QD (for Q models)
 Straight connector models listed;
 for right-angle, **W** replaces **G** in
 the model number.
 (example, **PKW3M-2**)

3-Pin
PKG3M-2
 2 m (6')
PKG3M-5
 5 m (15')
PKG3M-9
 9 m (30')

Reflectors



*Additional information is available
 See page 790*

*Additional cordset information is available
 See page 758*



SMBVS1T



SMBVS1TC



SMBVS1S



SMBVS1SC

*Additional bracket information is available
 See page 724*



VS1 Specifications

Supply Voltage and Current	10 to 30 V dc (10% max. ripple) at less than 25 mA (exclusive of load)
Supply Protection Circuitry	Protected against reverse polarity and transient voltages
Output Configuration	Solid-state switch NPN (current sinking) or PNP (current sourcing), depending on model Light Operate (LO) or Dark Operate (DO) models
Output Rating	50 mA max. OFF-state leakage current: less than 1 μ A at 24 V dc ON-state saturation voltage: less than 0.25 V at 10 mA dc; less than 0.5 V at 50 mA dc
Output Protection Circuitry	Protected against false pulse on power-up and continuous overload or short circuit of outputs Overload trip point \geq 100 mA
Output Response Time	1 millisecond ON/OFF
Repeatability	250 microseconds
Indicators	Two LEDs: Solid Green: power ON Solid Yellow: light sensed Flashing Green: output over loaded Flashing Yellow: marginal excess gain
Construction	Black ABS/polycarbonate housing with clear acrylic lens
Environmental Rating	IP54; NEMA 3
Connections	2 m or 9 m attached cable, or 150 mm pigtail with 3-pin Pico-style quick-disconnect fitting. QD cables are ordered separately.
Operating Conditions	Temperature: -20° to +55° C Relative humidity: 80% at 50° C (non-condensing)
Application Notes	M2 stainless steel mounting hardware is included. Optional mounting brackets are available.

Certifications



VS2 Series

Flat Pack Miniature Sensors



- Offers flat-front mounting or optional bracket
- Reliable sensing without adjustments
- Models available in opposed or convergent modes

Opposed VS2

➔ Visible Red LED ➔ Infrared LED

Sensing Mode	Range	Connection	Output Type	Models NPN†	Models PNP†	
<p>OPPOSED</p>	Optimum up to 600 mm, 1.2 m max.	2 m	-	VS25EV Emitter		
		3-Pin Pico Pigtail QD		VS25EVQ Emitter		
		2 m		LO	VS2AN5R	VS2AP5R
		3-Pin Pico Pigtail QD		VS2AN5RQ	VS2AP5RQ	
<p>OPPOSED</p>	3.0 m	2 m	DO	VS2RN5R	VS2RP5R	
		3-Pin Pico Pigtail QD		VS2RN5RQ	VS2RP5RQ	
		2 m		-	VS25E Emitter	
		3-Pin Pico Pigtail QD		VS25EQ Emitter		
<p>OPPOSED</p>	3.0 m	2 m	LO	VS2AN5R	VS2AP5R	
		3-Pin Pico Pigtail QD		VS2AN5RQ	VS2AP5RQ	
		2 m		DO	VS2RN5R	VS2RP5R
		3-Pin Pico Pigtail QD			VS2RN5RQ	VS2RP5RQ

Convergent VS2

➔ Visible Red LED

Sensing Mode	Range	Connection	Output Type	Models NPN†	Models PNP†	
<p>CONVERGENT</p>	15 mm ±5 mm	2 m	LO	VS2AN5CV15	VS2AP5CV15	
		3-Pin Pico Pigtail QD		VS2AN5CV15Q	VS2AP5CV15Q	
		2 m		DO	VS2RN5CV15	VS2RP5CV15
		3-Pin Pico Pigtail QD			VS2RN5CV15Q	VS2RP5CV15Q
<p>CONVERGENT</p>	30 mm ±10 mm	2 m	LO	VS2AN5CV30	VS2AP5CV30	
		3-Pin Pico Pigtail QD		VS2AN5CV30Q	VS2AP5CV30Q	
		2 m		DO	VS2RN5CV30	VS2RP5CV30
		3-Pin Pico Pigtail QD			VS2RN5CV30Q	VS2RP5CV30Q

➔ Connection options: A model with a QD requires a mating cordset.
 For 9 m cable, add suffix W/30 to the 2 m model number (example, VS2RP5R W/30).
 † Opposed-mode models also sold as pairs. Contact factory for more information 1-888-373-6767.



3-Pin
PKG3M-2
 2 m (6')
PKG3M-5
 5 m (15')
PKG3M-9
 9 m (30')

Pico QD (for Q models)
 Straight connector models listed;
 for right-angle, **W** replaces **G** in
 the model number.
 (example, **PKW3M-2**)

Additional cordset information is available
 See page 758

Reflectors



Additional information is available
 See page 790

Appartures



Additional information is available
 See page 816



SMBVS2RA

Additional bracket information is available
 See page 724



Opposed Models
 Suffix E and R



Convergent Models
 Suffix C

VS2 Specifications

Supply Voltage and Current	10 to 30 V dc (10% max. ripple) Emitter: 25 mA (visible red); 30 mA (infrared) Receiver (Convergent): at less than 25 mA (exclusive of load)
Supply Protection Circuitry	Protected against reverse polarity and transient voltages
Output Configuration	Solid-state switch NPN (current sinking) or PNP (current sourcing), depending on model Light Operate (LO) or Dark Operate (DO), depending on model
Output Rating	50 mA max. OFF-state leakage current: less than 1 μ A at 24 V dc ON-state saturation voltage: less than 0.25 V at 10 mA dc; less than 0.5 V at 50 mA dc
Output Protection Circuitry	Protected against false pulse on power-up and continuous overload or short circuit of outputs Overload trip point \geq 100 mA
Output Response Time	Opposed: 1 millisecond ON; 0.5 millisecond OFF Convergent: 1 millisecond ON; OFF
Delay at Power-up	Maximum 100 millisecond (opposed) and 150 millisecond (convergent); output does not conduct during this time
Repeatability	Opposed: 100 microseconds Convergent: 160 microseconds
Indicators	Two LEDs: Solid Green: power ON Flashing Green: output overload Solid Yellow: light sensed Flashing Yellow (opposed mode only): marginal excess gain
Construction	Opposed: Black ABS housing with clear MABS lens Convergent: Black ABS housing with acrylic lens
Environmental Rating	IEC IP67; NEMA 6
Connections	2 m or 9 m attached cable or 150 mm pigtail with 3-pin Pico-style quick-disconnect fitting. QD cordsets are ordered separately.
Operating Conditions	Temperature: -20° to +55° C Relative humidity: 80% at 50° C (non-condensing)
Vibration and Mechanical Shock	Vibration: All models meet IEC 60068-2-6, IEC 60947-5-2, UL491 Section 40, MIL-STD-202F Method 201A; 10 to 60 Hz, 0.5 mm peak to peak All models meet IEC 60068-2-27, IEC 60947-5-2; 30g peak acceleration, 11 millisecond pulse duration, half-sine wave pulse shape
Application Notes	M2 stainless steel mounting hardware is included. Optional mounting brackets are available.

Certifications



VS3 Series

Miniature Sensors with Advanced Optics



- Reliable sensing without adjustments
- Uses coaxial optics to eliminate blind areas at close range
- Accurately detects shiny objects
- Visible sensing beam for easy alignment

Coaxial & Coaxial Polar Retro VS3

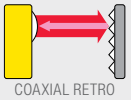
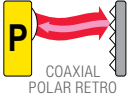
Sensing Mode	Range [†]	Connection	Output Type	Models NPN	Models PNP
 COAXIAL RETRO	250 mm	2 m	LO	VS3AN5XLV	VS3AP5XLV
		3-Pin Pico QD		VS3AN5XLVQ	VS3AP5XLVQ
		2 m	DO	VS3RN5XLV	VS3RP5XLV
		3-Pin Pico QD		VS3RN5XLVQ	VS3RP5XLVQ
 COAXIAL POLAR RETRO	250 mm	2 m	LO	VS3AN5XLP	VS3AP5XLP
		3-Pin Pico QD		VS3AN5XLPQ	VS3AP5XLPQ
		2 m	DO	VS3RN5XLP	VS3RP5XLP
		3-Pin Pico QD		VS3RN5XLPQ	VS3RP5XLPQ

 Connection options: A model with a QD requires a mating cordset .
 For 9 m cable, add suffix W/30 to the 2 m model number (example, VS3AN5XLV W/30).
[†] Retroreflective range is specified using one model BRT-32X20AM retroreflector. Actual sensing range may differ, depending on efficiency and reflective area of the retroreflector in use.
 See accessories for more information.



3-Pin

Pico QD (for Q models)
 Straight connector models listed;
 for right-angle, **W** replaces **G** in
 the model number.
 (example, **PKW3M-2**)

- PKG3M-2**
2 m (6')
- PKG3M-5**
5 m (15')
- PKG3M-9**
9 m (30')

Additional cordset information is available
 See page 758

Reflectors



Additional information is available
 See page 790



Non-Polarized Retroreflective Models
 Suffix LV



SMBVS3S



SMBVS3T

Additional bracket information is available
 See page 724

VS3 Specifications

Supply Voltage and Current	10 to 30 V dc (10% max. ripple) at less than 25 mA (exclusive of load)
Supply Protection Circuitry	Protected against reverse polarity and transient voltages
Output Configuration	Solid-state switch NPN (current sinking) or PNP (current sourcing), depending on model Light Operate (LO) or Dark Operate (DO), depending on model
Output Protection Circuitry	Protected against false pulse on power-up and continuous overload or short circuit of outputs Overload trip point \geq 100 mA
Output Rating	50 mA max. OFF-state leakage current: less than 1 μ A at 24 V dc ON-state saturation voltage: less than 0.25 V at 10 mA dc; less than 0.5 V at 50 mA dc
Output Response Time	1 millisecond ON/OFF
Delay at Power-up	150 millisecond; output does not conduct during this time
Repeatability	160 microseconds
Indicators	Two LEDs: Solid Green: power ON Flashing Green: output over loaded Solid Yellow: light sensed
Construction	Non-polarized Retroreflective: Black ABS housing with acrylic lens Polarized Retroreflective: Black ABS housing with glass lens and acrylic cover
Environmental Rating	IEC IP67; NEMA 6
Connections	2 m or 9 m attached cable, or 3-pin Pico-style quick-disconnect fitting. QD cordsets are ordered separately.
Operating Conditions	Temperature: -20° to +55° C Relative humidity: 80% at 50° C (non-condensing)
Vibration and Mechanical Shock	Vibration: All models meet IEC 60068-2-6, IEC 60947-5-2, UL491 Section 40, MIL-STD-202F Method 201A; 10 to 60 Hz, 0.5 mm peak to peak Shock: All models meet IEC 60068-2-27, IEC 60947-5-2; 30g peak acceleration, 11 millisecond pulse duration, half-sine wave pulse shape
Application Notes	M3 stainless steel mounting hardware is included. Optional mounting brackets are available.



Certifications





Fiber Optics

Fiber optic cables are ideal for harsh conditions including high vibration, extreme heat, noisy, wet, corrosive or explosive environments. Fiber optic sensors have thin profiles, allowing for close mounting of multiple units and mounting in confined areas. Sensors can be positioned precisely where needed with flexible fibers.

Series	Description	Output Response Time	Dimensions H x W x D	Housing Material	Power Supply
	DF-G3 Long-range easy to read dual display fiber amplifier page 164	500 μ s varies by model	33.0 x 72.0 x 10.0 mm	Thermoplastic	NPN/PNP models: 10 to 30 V dc IO-Link models: 18 to 30 V dc
	DF-G2 High-speed easy to read dual display fiber amplifier page 166	10 μ s (varies by model)	33.0 x 72.0 x 10.0 mm	Thermoplastic	NPN/PNP models: 10 to 30 V dc IO-Link models: 18 to 30 V dc
	DF-G1 Easy to read dual display fiber amplifier page 168	High Speed: 200 μ s Long Range: 2 ms Extra Long Range: 5 ms	33.0 x 72.0 x 10.0 mm	Thermoplastic	NPN/PNP models: 10 to 30 V dc IO-Link models: 18 to 30 V dc
	D10 Advanced fiber optic amplifier page 172	varies by model	35.9 x 68.1 x 10.0 mm	Thermoplastic	12 to 24 V dc
	Plastic Fibers page 174				
	Glass Fibers page 192				

OTHER AVAILABLE MODELS



R55F see website

DF-G3 Series

Long-range Fiber Optic Amplifiers



- World-class long-range sensing capability, more than 3 m (10 ft) with opposed mode fibers
- Easy to read dual digital displays show both signal level and threshold simultaneously
- Cross-talk avoidance function allows seven inspections in dense sensing point applications
- Models with IO-Link enable a point-to-point communication link between a master device and a sensor, facilitating remote monitoring, teaching, and configuration
- Operator control of the sensitivity (hysteresis) provides additional detection sensitivity, or a stabilized output depending on the application details

IO-Link DF-G3

Sensing Beam Color	Range*	Connection	Output	Models
Visible Red, 635 nm	3,000 mm	2 m	Channel1: IO-Link, push/pull Channel 2: PNP only output, or input	DF-G3-KD-2M
Infrared, 850 nm**	6,000 mm	2 m	Channel1: IO-Link, push/pull Channel 2: PNP only output, or input	DF-G3IR-KD-2M

Single Output DF-G3

Sensing Beam Color	Range*	Connection	NPN Models	PNP Models
Visible Red	3,000 mm	2 m	DF-G3-NS-2M	DF-G3-PS-2M
Infrared, 850 nm**	6,000 mm	2 m	DF-G3IR-NS-2M	DF-G3IR-PS-2M

Dual Output DF-G3

Sensing Beam Color	Range*	Connection	NPN Models	PNP Models
Visible Red	3,000 mm	2 m	DF-G3-ND-2M	DF-G3-PD-2M
Infrared, 850 nm**	6,000 mm	2 m	DF-G3IR-ND-2M	DF-G3IR-PD-2M

Analog DF-G3

Sensing Beam Color	Range*	Connection	Supply Voltage	NPN Models	PNP Models
Visible Red	3,000 mm	2 m	Voltage: 12-30 V DC	DF-G3-NU-2M	DF-G3-PU-2M
			Current: 10-30 V DC	DF-G3-NI-2M	DF-G3-PI-2M
Infrared, 850 nm**	6,000 mm	2 m	Voltage: 12-30 V DC	DF-G3IR-NU-2M	DF-G3IR-PU-2M
			Current: 10-30 V DC	DF-G3IR-NI-2M	DF-G3IR-PI-2M

For more specifications see page 169

 Connection Option: A model with a QD requires a mating cordset. (see page 169)

* Excess gain = 1, Long Range response speed, opposed mode sensing.

** IR models require T5 terminated glass fiber optic cables

DF-G3 Series

Water Detection Fiber Optic Amplifiers



- 1450 nm infrared wavelength to enhance contrast of clear liquids
- Reliable detection of presence or absence of water-based liquids
- Easy to read dual digital displays show both signal level and threshold simultaneously
- Cross-talk avoidance function allows seven inspections in dense sensing point applications
- Models with IO-Link enable a point-to-point communication link between a master device and a sensor, facilitating remote monitoring, teaching, and configuration
- Cordsets and brackets see page 169

Single Output DF-G3

Sensing Beam Color	Range*	Connection	NPN Models	PNP Models
Long Infrared, 1450 nm**	900 mm	2 m	DF-G3LIR-NS-2M	DF-G3LIR-PS-2M

Dual Output DF-G3

Sensing Beam Color	Range*	Connection	NPN Models	PNP Models
Long Infrared, 1450 nm**	900 mm	2 m	DF-G3LIR-ND-2M	DF-G3LIR-PD-2M

Analog DF-G3

Sensing Beam Color	Range*	Connection	Supply Voltage	NPN Models	PNP Models
Long Infrared, 1450 nm**	900 mm	2 m	Voltage: 12-30 V DC	DF-G3LIR-NU-2M	DF-G3LIR-PU-2M
			Current: 10-30 V DC	DF-G3LIR-NI-2M	DF-G3LIR-PI-2M

For more specifications see page 169

 Connection Option: A model with a QD requires a mating cordset. (see page 169)

* Excess gain = 1, Long Range response speed, opposed mode sensing.

** IR models require T5 terminated glass fiber optic cables

DF-G2 Series

High-Speed *Expert*™ Fiber Optic Amplifiers



- The high speed DF-G2 fiber amplifiers now offer several LED colors to maximize contrast in challenging low-contrast applications
- Best in Class response time
- Programming via displays and switches/buttons or remote input teach wire
- *Expert* TEACH and SET methods ensure optimal gain and threshold for all applications, especially low contrast applications
- Cross talk avoidance algorithm allows two sensors to operate in close proximity for many applications

IO-Link DF-G2

Sensing Beam Color	Range	Connection	Output	Models
Visible Red, 635 nm	1,100 mm	2 m	Channel 1: IO-Link, push/pull Channel 2: PNP only output, or input	DF-G2-KD-2M
Infrared, 850 nm*	2,100 mm	2 m	Channel 1: IO-Link, push/pull Channel 2: PNP only output, or input	DF-G2IR-KD-2M

DF-G2

Sensing Beam Color	Range	Connection	NPN Models	PNP Models
Visible Red	Range varies by response speed and fiber optics used	2 m	DF-G2-NS-2M	DF-G2-PS-2M

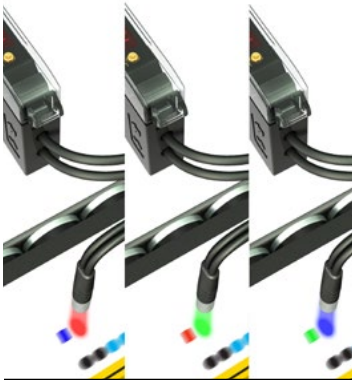

Multiple Color DF-G2

Sensing Beam Color	Range	Connection	NPN Models	PNP Models
Broad Spectrum White	50% of Visible Red Range	2 m	DF-G2W-NS-2M	DF-G2W-PS-2M
Visible Green	60% of Visible Red Range	2 m	DF-G2G-NS-2M	DF-G2G-PS-2M
Visible Blue	70% of Visible Red Range	2 m	DF-G2B-NS-2M	DF-G2B-PS-2M
Infrared*	190% of Visible Red Range	2 m	DF-G2IR-NS-2M	DF-G2IR-PS-2M

DF-G2 Multiple color

Multiple LED color options available.

For more specifications see page 170.

Connection options: A model with a QD requires a mating cordset (see page 169).

For 9 m cable, change the suffix 2M to 9M in the 2 m model number (example, DF-G2-NS-9M).

For M8 pico pigtail, change the suffix 2M to Q3 in the 2 m model number (example, DF-G2-NS-Q3).

For M12 euro pigtail, change the suffix 2M to Q5 in the 2 m model number (example, DF-G2-NS-Q5).

* IR models require T5 terminated glass fiber optic cables

DF-G2 Series

Small Object Fiber Optic Amplifiers



- The DF-G2 Series uses Banner's unique firmware designed to achieve accurate, high speed, low contrast performance for small object detection applications
- Percent-based threshold selectable from 2% to 50% for sensitivity adjustment
- Automatic Gain Compensation (AGC) algorithm compensates for dust build-up on fiber optics to extend counting cycle and maintain count accuracy
- Intelligent Dynamic Event Stretcher (DES) minimizing chance for double-counting, even with non-uniform objects (i.e. gel caps, washers, etc.)

DF-G2

Sensing Beam Color	Range	Connection	NPN Models	PNP Models
Visible Red, 635 nm	Range varies by response speed and fiber optics used	2 m	DF-G2-NC-2M	DF-G2-PC-2M

Fiber Optic Arrays for DF-G2

Sensing Beam Color	Window Size	Fiber Exit	Minimum Object Size	Model
Visible Red, 635 nm	10 x 25 mm	Side Exit	1.5 mm	PFCVA-10X25-S
		End Exit		PFCVA-10X25-E
Visible Red, 635 nm	25 x 25 mm	Side Exit	3 mm	PFCVA-25X25-S
		End Exit		PFCVA-25X25-E
Visible Red, 635 nm	34 x 25 mm	Side Exit	4 mm	PFCVA-34X25-S
		End Exit		PFCVA-34X25-E



DF-G2 and array fibers

Multiple array fiber models available.

For more specifications see page 170.

Connection options: A model with a QD requires a mating cordset (see page 169)

For 9 m cable, change the suffix 2M to 9M in the 2 m model number (example, DF-G2-NC-9M).

DF-G1 Series

Expert™ Dual-Display Fiber Optic Amplifiers



- The DF-G1 Series has a simple user interface to ensure easy sensor set-up and programming via displays and switches/buttons, remote input teach wire or IO-Link
- End user has full control over operating parameters, including Light/Dark Operate, output timing functions, gain level and response speed
- Cross talk avoidance algorithm allows multiple sensors to operate in close proximity
- Light receiver models detect light emission from a wide variety of sources

IO-Link DF-G1

Sensing Beam Color	Range	Connection	Output	Models
Visible Red, 660 nm	Range varies by Speed Selection used and with fiber optics used. See fibers section on page 174 or reference website for range information.	2 m	Channel1: IO-Link, push/pul Channel 2: PNP only output, or input	DF-G1-KS-2M

DF-G1

Sensing Beam Color	Range	Connection	NPN Models	PNP Model
Visible Red, 660 nm	Range varies by Speed Selection used and with fiber optics used. See fibers section on page 174 or reference website for range information.	2 m	DF-G1-NS-2M	DF-G1-PS-2M

Light Receiver DF-G1

Sensing Beam Color	Range	Connection	NPN Models	PNP Model
Visible Red, 660 nm	Range varies by response speed used, gain setting, target light source intensity, ambient light level and with fiber optics used. See fibers section on page 174 or reference website for range information.	2 m	DF-G1-NR-2M	DF-G1-PR-2M

 Connection options: A model with a QD requires a mating cordset

For 9 m cable, change the suffix 2M to 9M in the 2 m model number (example, DF-G1-NS-9M).
 For M8 Pico pigtail change the suffix 2M to Q3 in the 2 m model number (example, DF-G1-NS-Q3).
 For M12 Euro pigtail change the suffix 2M to Q5 in the 2 m model number (example, DF-G1-NS-Q5).

Euro QD
(for ..Q8 or ..Q5 models)
Straight connector models listed; for right-angle, add **RA** to the end of the model number (example, **MQDC-406RA**)



4-Pin
MQDC-406
2 m (6')
MQDC-415
5 m (15')
MQDC-430
9 m (30')

Pico QD
(for Q7 models)
Straight snap-on connector

Pico QD (for Q7 models)
Right-angle snap-on connector



4-Pin
PKG4-2
2 m (6')
PKW4Z-2
2 m (6')

Additional cordset information is available
See page 758



DIN-35..



SA-DIN-BRACKET

Mounting Clamp



SA-DIN-CLAMP

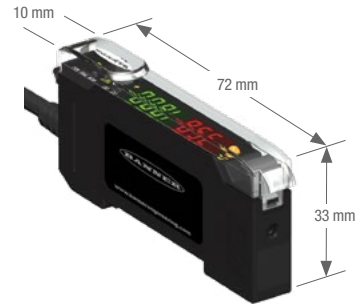



Additional bracket information is available
See page 730



DF-G1 Specifications

Supply Voltage and Current	NPN/PNP Models: 10 to 30 V dc (10% max ripple) Standard Mode: 960 mW, Current consumption < 40 mA @ 24 V dc	IO-Link Models: 18 to 30 V dc (10% max ripple) ECO Display Mode: 720 mW, Current consumption < 30 mA @ 24 V dc
Supply Protection Circuitry	Protected against reverse polarity, over voltage, and transient voltages	
Output Configuration	NPN/PNP Models: 1 current sourcing (PNP) or 1 current sinking (NPN) output, depending on model IO-Link Models: 1 push-pull and 1 PNP (complementary outputs)	
Output Rating	100 mA max. load (derate 1 mA per °C above 30 °C) OFF-state leakage current: NPN/PNP: < 5 µA at 30 V dc IO-Link: < 50 µA at 30 V dc ON-state saturation voltage: NPN: < 1.5 V PNP: < 2 V IO-Link: < 2 V	
Output Protection Circuitry	Protected against output short-circuit, continuous overload, transient over-voltages, and false pulse on power up	
Output Response Time	High Speed: 200 us Long Range: 2 ms Light receiver models: 50 ms, 150 ms	Standard: 500 us Extra Long Range: 5 ms
Delay at Power-up	500 milliseconds max.; outputs do not conduct during this time	
Adjustments	3-way RUN/PRG/ADJ Mode Switch 2-way LO/DO Switch 3-way +/SET/- Rocker Button See datasheet for detailed information	
Indicators	Red 4-digit Display: Signal Level Green 4-digit Display: Threshold Yellow LED: Output conducting (In Program Mode, Red and Green displays are used for programming menus)	
Construction	Black ABS/polycarbonate alloy (UL94 V-0 rated) housing, clear polycarbonate cover	
Environmental Rating	IEC IP50, NEMA 1	
Operating Conditions	Temperature: -10 to +55 °C	Storage: -20 to +85 °C Relative Humidity: 90% @ 60 °C (non-condensing)
Certifications		

DF-G2 Specifications

Supply Voltage and Current	10 to 30 V dc (10% max ripple)																														
Supply Protection Circuitry	Protected against reverse polarity, over voltage, and transient voltages Standard display mode: 960 mW, Current consumption less than 40 mA at 24 V dc ECO display mode: 720 mW, Current consumption less than 30 mA at 24 V dc																														
Output Configuration	NPN/PNP Models: 1 current sourcing (PNP) or 1 current sinking (NPN) output, depending on model, plus 1 Health Mode output																														
Output Rating	100 mA max. load (derate 1 mA per °C above 30 °C) OFF-state leakage current: NPN/PNP: < 5 µA at 30 V dc ON-state saturation voltage: NPN: < 1.5 V PNP: < 2 V																														
Output Protection Circuitry	Protected against output short-circuit, continuous overload, transient over-voltages, and false pulse on power up																														
Sensing Beam	DF-G2: Visible red, 635 nm DF-G2W: Broad spectrum white, 450 to 650 nm DF-G2B: Visible blue, 470 nm DF-G2G: Visible green, 525 nm DF-G2IR: Infrared, 850 nm																														
Output Response Time	<table border="0"> <tr> <td>Super High Speed: 10 µs</td> <td>High Speed: 15 µs</td> </tr> <tr> <td>Fast: 50 µs</td> <td>Standard: 250 µs</td> </tr> <tr> <td>Medium Range: 500 µs</td> <td>Long Range: 1000 µs</td> </tr> <tr> <td colspan="2">Long Range with immunity to Energy Efficient Lights: 2000 µs</td> </tr> <tr> <td colspan="2"> </td> </tr> <tr> <td>Super High Speed: 10 µs</td> <td>High Speed: 15 µs</td> </tr> <tr> <td>Fast: 50 µs</td> <td>Standard: 250 µs</td> </tr> <tr> <td>Medium Range: 500 µs</td> <td>Long Range: 1000 µs</td> </tr> <tr> <td colspan="2"> </td> </tr> <tr> <td colspan="2">DF-G2 Small Object Counter: 25 µs</td> </tr> <tr> <td></td> <td>50 µs</td> </tr> <tr> <td></td> <td>150 µs</td> </tr> <tr> <td></td> <td>250 µs</td> </tr> <tr> <td></td> <td>500 µs</td> </tr> </table>			Super High Speed: 10 µs	High Speed: 15 µs	Fast: 50 µs	Standard: 250 µs	Medium Range: 500 µs	Long Range: 1000 µs	Long Range with immunity to Energy Efficient Lights: 2000 µs				Super High Speed: 10 µs	High Speed: 15 µs	Fast: 50 µs	Standard: 250 µs	Medium Range: 500 µs	Long Range: 1000 µs			DF-G2 Small Object Counter: 25 µs			50 µs		150 µs		250 µs		500 µs
Super High Speed: 10 µs	High Speed: 15 µs																														
Fast: 50 µs	Standard: 250 µs																														
Medium Range: 500 µs	Long Range: 1000 µs																														
Long Range with immunity to Energy Efficient Lights: 2000 µs																															
Super High Speed: 10 µs	High Speed: 15 µs																														
Fast: 50 µs	Standard: 250 µs																														
Medium Range: 500 µs	Long Range: 1000 µs																														
DF-G2 Small Object Counter: 25 µs																															
	50 µs																														
	150 µs																														
	250 µs																														
	500 µs																														
Repeatability	<table border="0"> <tr> <td>Super High Speed: 5 µs</td> <td>High Speed: 5 µs</td> </tr> <tr> <td>Fast: 12 µs</td> <td>Standard: 50 µs</td> </tr> <tr> <td>Medium Range: 80 µs</td> <td>Long Range: 165 µs</td> </tr> <tr> <td colspan="2">Long Range with immunity to Energy Efficient Lights: 165 µs</td> </tr> <tr> <td colspan="2"> </td> </tr> <tr> <td colspan="2">DF-G2 Small Object Counter: 12 µs</td> </tr> <tr> <td></td> <td>12 µs</td> </tr> <tr> <td></td> <td>30 µs</td> </tr> <tr> <td></td> <td>50 µs</td> </tr> <tr> <td></td> <td>80 µs</td> </tr> </table>			Super High Speed: 5 µs	High Speed: 5 µs	Fast: 12 µs	Standard: 50 µs	Medium Range: 80 µs	Long Range: 165 µs	Long Range with immunity to Energy Efficient Lights: 165 µs				DF-G2 Small Object Counter: 12 µs			12 µs		30 µs		50 µs		80 µs								
Super High Speed: 5 µs	High Speed: 5 µs																														
Fast: 12 µs	Standard: 50 µs																														
Medium Range: 80 µs	Long Range: 165 µs																														
Long Range with immunity to Energy Efficient Lights: 165 µs																															
DF-G2 Small Object Counter: 12 µs																															
	12 µs																														
	30 µs																														
	50 µs																														
	80 µs																														
Construction	Black ABS/polycarbonate alloy (UL94 V-0 rated) housing, clear polycarbonate cover																														
Environmental Rating	IEC IP50, NEMA 1																														
Operating Conditions	Temperature: -10 to +55 °C	Storage: -20 to +85 °C	Relative Humidity: 90% @ 60 °C (non-condensing)																												
Certifications	 																														

DF-G3 Specifications

Supply Voltage and Current	NPN/PNP Models: 10 to 30 V dc (10% max ripple) Voltage output models: 12 to 30 V dc (10% max ripple) Standard Mode: 960 mW, Current consumption < 40 mA @ 24 V dc	IO-Link Models: 18 to 30 V dc (10% max ripple) Current output models: 10 to 30 V dc (10% max ripple) ECO Display Mode: 720 mW, Current consumption < 30 mA @ 24 V dc
Supply Protection Circuitry	Protected against reverse polarity, over voltage, and transient voltages	
Sensing Beam	DF-G3: Visible red, 635 nm DF-G3IR: Infrared, 850 nm DF-G3LIR: Long Infrared, 1450 nm	
Output Configuration	NPN/PNP Models: 1 current sourcing (PNP) or 1 current sinking (NPN) output, depending on model IO-Link Models: 1 push-pull and 1 PNP (complementary outputs) Voltage output models: 1 analog voltage output (user configurable as 1 V to 5 V or 0 V to 10 V) with 1 current sinking (NPN) or 1 current sourcing (PNP) discrete output Current output models: 1 analog current output (4 mA to 20 mA) with 1 current sinking (NPN) or 1 current sourcing (PNP) discrete output	
Output Rating	100 mA max. load (derate 1 mA per °C above 30 °C) OFF-state leakage current: NPN/PNP/current: < 5 µA at 30 V dc IO-Link: < 50 µA at 30 V dc ON-state saturation voltage: NPN: < 1.5 V PNP: < 2 V IO-Link: < 2 V	
Output Protection Circuitry	Protected against output short-circuit, continuous overload, transient over-voltages, and false pulse on power up	
Output Response Time	High Speed: 500 us Fast: 1000 us Standard: 2 ms Long Range: 8 ms Extra Long Range: 24 ms	
Delay at Power-up	500 milliseconds max.; outputs do not conduct during this time	
Indicators	Red 4-digit Display: Signal Level Green 4-digit Display: Threshold Yellow LED: Output conducting (In Program Mode, Red and Green displays are used for programming menus)	
Construction	Black ABS/polycarbonate alloy (UL94 V-0 rated) housing, clear polycarbonate cover	
Environmental Rating	IEC IP50, NEMA 1	
Operating Conditions	Temperature: -10 to +55 °C Storage: -20 to +85 °C	Relative Humidity: 50% @ +50 °C (non-condensing)
Certifications	  	

D10 Series

High-Speed *Expert*™ Fiber Optic Amplifiers



- Available with visible red or green beam
- Available in Light or Dark Operate
- Includes specially designed models for reliable detection of objects as small as 1.5 mm
- Features bussable models for side-by-side mounting and simplified wiring of up to 16 sensors
- Features thin 10 mm housing for standard 35 mm DIN-rail mounting

D10

Sensing Beam Color	Range	Connection	Output Type	Response Speed	Models
Visible Red	Range varies by Power Level/Speed Selection used and with fiber optics used. See fibers section on page 174 or reference datasheet for range information.	2 m	Bipolar NPN/PNP	500 ms	D10AFP
Visible Green		2 m		500 ms	D10AFPG
Visible Red		2 m		200 ms	D10AFPY
Visible Green		2 m		200 ms	D10AFPGY



Connection options: A model with a QD requires a mating cordset

For 4-pin Snap-on Pico QD cable, add suffix Q to the 2 m model number (example, D10AFPQ).

Pico QD
(for Q7 models)
Straight snap-on connector

Pico QD (for Q7 models)
Right-angle snap-on connector



4-Pin
PKG4-2
2 m (6')

PKW4Z-2
2 m (6')

6-Pin
PKG6Z-2
2 m (6')

PKW6Z-2
2 m (6')



DIN-35..



SMBR55F01



SMBR55FRA

Additional cordset information is available
See page 758

Additional bracket information is available
See page 730



D10—Discrete Specifications

Required Fiber Optic Cable	Banner P-Series plastic fibers (See Plastic Fiber Optic section, page 174)
Supply Voltage & Current	10 to 30 V dc (10% max. ripple) @ less than 25 mA, exclusive of load
Supply Protection Circuitry	Protected against reverse polarity and transient voltage
Output Configuration	Bipolar: 1 current sourcing (PNP) and 1 current sinking (NPN)
Output Rating	100 mA per output with short circuit protection OFF-state leakage current: less than 10 µA sourcing; 200 µA sinking ON-state saturation voltage: NPN: 1.6 V @ 100 mA PNP: 2.0 V @ 100 mA
Output Protection Circuitry	Protected against output short-circuit and false pulse on power up
Delay at Power-up	Max. 100 milliseconds; outputs do not conduct during this time
Output Response Time	Standard models (with crosstalk avoidance circuitry): 500 microseconds High-speed models: 200 microseconds
Repeatability	Standard models: 95 microseconds High-speed models: 50 microseconds
Adjustments	12-turn Sensitivity potentiometer with relative position indicator; LO/DO Selection switch; 0 or 40 milliseconds OFF-delay switch NOTE: Use proper ESD techniques while making adjustments under cover
Indicators	Two LEDs: Green and Yellow Green: Power ON Yellow: Light Sensed Signal strength indicator See datasheet for detailed information
Construction	Black ABS/polycarbonate alloy (UL94 V-0 rated) housing, clear polycarbonate cover
Environmental Rating	IEC IP50; NEMA 1
Operating Conditions	Temperature: -10 to +55 °C Storage: -20 to +85 °C Relative humidity: 90% @ 55 °C (non-condensing)

Certifications



Plastic Fiber Optics

Provide an economical alternative to glass fiber optics for piping photoelectric sensing light to and from confined areas with suitable environments

- Ideal for detecting small objects
- Withstand repeated flexing and bending
- Available in individual or bifurcated styles
- Available with core diameters of 0.25, 0.50, 0.75, 1.0 and 1.5 mm



Choosing Plastic or Glass

Plastic fibers are for general purpose use. They tolerate severe flexing, can be cut to length in the field and cost less than glass fibers. Glass fibers are the best choice for challenging environments such as high temperatures, corrosive materials and moisture.



Fiber Construction

- Core:** Thin glass or plastic center of the fiber through which light travels
- Cladding:** Outer optical material surrounding the core that reflects light back into the core
- Jacket/Sheath:** Protective layer to protect fiber from damage and moisture



Plastic fibers page 174

- Inexpensive and easily cut to length during installation
- Bend for a precise fit
- Available in high-flex models to withstand flexing
- Offered with special jackets that withstand corrosion, impact and abrasion
- Available for applications requiring articulated or reciprocating motion
- Available in diameters of 0.25, 0.5, 1.0 Or 1.5 mm
- Can be quickly custom designed and built for your unique applications



Glass fibers page 192

- Solve numerous challenging sensing requirements
- Ideal for hostile environments such as high temperatures to 480° C, corrosive materials and extreme moisture
- Withstand high levels of shock and vibration
- Inherently immune to extreme electrical noise
- Available with choice of sheathings: standard stainless-steel flexible conduit, PVC or other flexible tubing
- Can be quickly custom designed

Model Key



PLASTIC FIBER FAMILY

Same for all plastic fibers

ASSEMBLY STYLE

- I = Individual fiber*
- DI = Dual Individual fiber*
- B = Bifurcated fiber

SENSING END

- A = 90° Angle
- AT = 90° Angle/Thread
- CF = Coaxial Ferrule
- CT = Coaxial Thread
- E = Encapsulated
- EFP = Extended Ferrule Probe
- F = Ferrule
- FM = Ferrule Miniature
- FMP = Ferrule Miniature Probe
- L = Lensed
- P = Probe
- PF = Probe Ferrule
- PMSB = Probe Miniature Side-view Bendable
- PS = Probe Side-view
- PSB = Probe Side-view Bendable
- PSM = Probe Side-view Miniature
- R = Rectangular
- RS = Rectangular Side-view
- T = Thread
- TA = Thread/90° Angle
- TP = Thread/Probe

MODIFICATIONS†

- MFR = Flex relief
- MSW = Slot width
- MTA = Tight angle
- MTL = Thread length
- MAL = Array length
- MPL = Probe length
- MFL = Ferrule length

CONTROL END

- U = Unterminated straight cable**
- UC = Unterminated Coiled cable
- UHF = Unterminated DURA-BEND™ multi-core cable
- T5 = Terminated
- TMB5 = SteelSkin™ braiding over monocoil reinforcement

FIBER LENGTH

- 3 = 1 m (1000 mm)
- 6 = 2 m (2000 mm)
- 15 = 5 m (5000 mm)
- 30 = 9 m (9,000 mm)
- 100 = 30 m (30,000 mm)

FIBER CORE DIAMETER

- 1 = 0.25 mm
- 2 = 0.50 mm
- 3 = 0.75 mm
- 4 = 1.00 mm
- 6 = 1.50 mm
- 1x4 = 4 x 0.25 mm
- 1x16 = 16 x 0.265 mm
- 1x32 = 32 x 0.265 mm

* All individual plastic fiber optics are sold and used in pairs. Bifurcated fibers are two-way fibers with a single sensing end that both emits and receives light and with dual-control sensor ends that attach separately to the sensor's LED and photodetector.
 ** Plastic fibers with "U" in the suffix of the model numbers have unterminated control ends; cut them to the required length using the supplied cutter.
 † Not all modifications can be applied to all fiber assemblies. Please consult factory for verification of modifications.

Specialty fibers for specific sensing applications

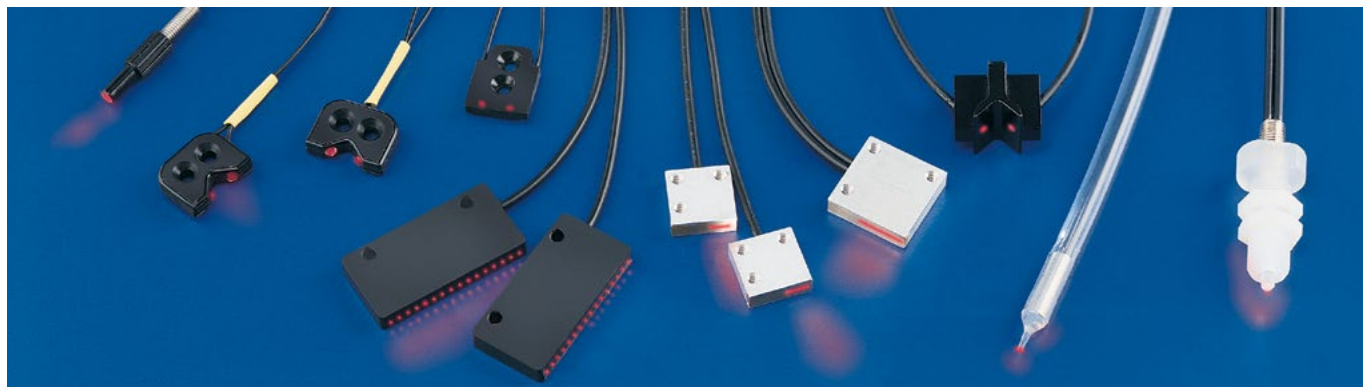

DURA-BEND™ for extremely tight radius bends



Fluoropolymer encapsulated fibers



Focused beam fibers



Convergent beam fibers



Linear array fibers



Liquid level detection fibers

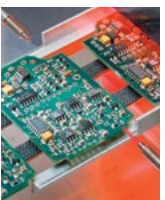

High temperature fibers





















SteelSkin™ for impact and abrasion

Vantage Line Plastic Fibers

- OEM friendly packaging
- No fiber cutter included
- Opposed models come as a pair

Opposed Vantage Line Fibers

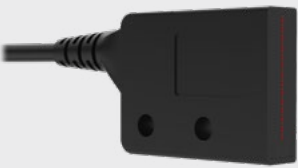

End Tip	Features	Minimum Bend Radius	Core Diameter	Free Cut	Typical Range (mm)	Models
	M6 threaded tip and integrated lens with flex relief 20 mm spot size at 100 mm	15 mm	0.5 mm		DF-G3 2000† DF-G2 2000 DF-G1 2000	PITL23UM6-VL*
	M4 threaded tip and integrated lens with flex relief 30 mm spot size at 100 mm	15 mm	0.5 mm		DF-G3 2000† DF-G2 2000 DF-G1 1680	PITL23UM4-VL*
	M4 & M2.6 threaded tip with flex relief	25 mm	1 mm		DF-G3 2000† DF-G2 1460 DF-G1 900	PIT43U-VL*
	M4 threaded tip with flex relief	25 mm	0.5 mm		DF-G3 1980 DF-G2 410 DF-G1 255	PIT23UM4-VL*
	M3 threaded tip with flex relief	25 mm	1 mm		DF-G3 2000† DF-G2 1450 DF-G1 895	PIT43UM3-VL*
	M3 threaded tip with flex relief	25 mm	0.5 mm		DF-G3 2000† DF-G2 440 DF-G1 270	PIT23U-VL*
	M4 & M2.6 threaded tip with flex relief 90° angle/thread	25 mm	1 mm		DF-G3 2000† DF-G2 1250 DF-G1 770	PIAT43UTA-VL*
	M4 & M2.6 threaded tip with flex relief 90° angle/thread	2 mm	1 mm		DF-G3 2000† DF-G2 1200 DF-G1 740	PIAT43UHFTA-VL*
	Rectangular housing with front exit 14.5 mm array	60 mm	32 x 0.25 mm	–	DF-G3 2000† DF-G2 1510 DF-G1 930	PIR1X323T-VL*
	M4 & M2.6 threaded tip with stainless protective jacket	25 mm	1 mm	–	DF-G3 2000† DF-G2 1700 DF-G1 1060	PIT43TSL5-VL*
	M4 & M2.6 threaded tip with stainless protective jacket 90° angle/thread	25 mm	1 mm	–	DF-G3 2000† DF-G2 1170 DF-G1 720	PIAT43TSL5TA-VL*

* For two meter cable lengths replace ...3., with 6 in the model number (example, PIT46U-VL)

† Max range determined by cable length 1 m = 2,000 mm

Diffuse Vantage Line Fibers



End Tip	Features	Minimum Bend Radius	Core Diameter	Free Cut	Typical Range (mm)	Models
	M6 threaded tip with flex relief	25 mm	1 mm		DF-G3 2000 [†] DF-G2 455 DF-G1 280	PBT43U-VL*
	M3 threaded tip with flex relief	25 mm	0.5 mm		DF-G3 855 DF-G2 180 DF-G1 110	PBT23U-VL*
	M4 & M2.6 thread non-bendable tip	25 mm	0.5 mm		DF-G3 815 DF-G2 170 DF-G1 105	PBT23UM4-VL*
	M6 threaded tip with flex relief 90° angle/thread	25 mm	1 mm		DF-G3 2000 [†] DF-G2 390 DF-G1 240	PBAT43UTA-VL*
	M6 threaded tip with flex relief 90° angle/thread	2 mm	1 mm		DF-G3 2000 [†] DF-G2 365 DF-G1 225	PBAT43UHFTA-VL*
	Rectangular housing with front exit 14.5 mm array	25 mm	32 x 0.25 mm		DF-G3 2000 [†] DF-G2 350 DF-G1 215	PBR1X323U-VL*
	M6 threaded tip with stainless protective jacket	25 mm	1 mm	-	DF-G3 2000 [†] DF-G2 500 DF-G1 310	PBT43TSL5-VL*
	M6 threaded tip with stainless protective jacket 90° angle/thread	25 mm	1 mm	-	DF-G3 2000 [†] DF-G2 435 DF-G1 270	PBAT43TSL5TA-VL*

* For two meter cable lengths replace ...3.. with 6 in the model number (example, PBT46U-VL)

† Max range determined by cable length 1 m = 2,000 mm (does not apply to diffuse models)



Array and Slot Fibers



Array and Slot fibers are customizable for a simple setup and provide an optimal solution for small part counting applications. Array fibers are ideal for broad spectrum detection and slot fibers are pre-aligned and easy to install.

- Quick and easy setup and alignment
- Small part counting applications
- Multiple beams can be customized for different array lengths
- Wide area detection
- Ideal for tracking applications, profiling parts, edge guiding, finding the edge of objects
- Opposed models come as a pair

Opposed Fibers



End Tip	Features	Minimum Bend Radius	Core Diameter	Free Cut	Typical Range (mm)	Models
	Ultra-compact head 5.25 mm straight exit Aluminium	5 mm	16 x 0.25 mm		DF-G3 4000† DF-G2 1040 DF-G1 640 D10A 260	PIR1X166U
	Ultra-compact head 5.25 mm side exit Aluminium	5 mm	16 x 0.25 mm		DF-G3 4000† DF-G2 1040 DF-G1 640 D10A 260	PIR1X166U
	Compact head 10 mm side exit Aluminium	5 mm	16 x 0.25 mm		DF-G3 4000† DF-G2 1230 DF-G1 760 D10A 260	PIR1X166UM.4
	19 mm side exit Plastic	5 mm	16 x 0.25 mm		DF-G3 4000† DF-G2 1245 DF-G1 770 D10A 270	PIR1X166UMPM.75
	34 mm side exit Plastic	5 mm	16 x 0.25 mm		DF-G3 4000† DF-G2 1100 DF-G1 680 D10A 260	PIR1X166UMPMAL
	Easy mount "fork" head Plastic	5 mm	1 mm		DF-G3 12 DF-G2 12 DF-G1 12 D10A 12	PDIS46UM12
	10 x 25 mm coverage Side (...S) or end exit (...E) Min. object detection of 1.5 mm	5 mm	16 x 0.25 mm	-	DF-G3 25 DF-G2 25 DF-G1 25 D10A 25	PFCVA-10X25-S PFCVA-10X25-E
	25 x 25 mm coverage Side (...S) or end exit (...E) Min. object detection of 3 mm	5 mm	16 x 0.25 mm	-	DF-G3 25 DF-G2 25 DF-G1 25 D10A 25	PFCVA-25X25-S PFCVA-25X25-E
	34 x 25 mm coverage Side (...S) or end exit (...E) Min. object detection of 4 mm	5 mm	16 x 0.25 mm	-	DF-G3 34 DF-G2 34 DF-G1 34 D10A 34	PFCVA-34X25-S PFCVA-34X25-E

† Max range determined by cable length 2 m = 4,000

STEELSKIN™ Fibers

SteelSkin™ rugged fiber models resist kinking, cutting and snagging and have a low profile to easily embed in machines. Ideal for busy assembly stations, embedded in stations, part presence or places where equipment is constantly moved on and off a production line.

- Abrasion resistant while maintaining flexibility
- Bend to tighter radius and thinner than standard plastic fiber optics
- Superior resistance to wear, chemicals and other environmental conditions
- Assembly stations, part presence, busy assembly cells
- Opposed models come as a pair



Opposed Fibers



End Tip	Features	Minimum Bend Radius	Core Diameter	Free Cut	Typical Range (mm)	Models
	Probe Stainless Steel Braid over monocoil	12 mm	1 mm	-	DF-G3 2000† DF-G2 1200 DF-G1 740 D10A 350	PITP43TMB5
	Ferrule Stainless Steel Braid over monocoil	12 mm	1 mm	-	DF-G3 2000† DF-G2 1200 DF-G1 740 D10A 350	PIF43TMB5
	Thread Stainless Steel Braid over monocoil	12 mm	1 mm	-	DF-G3 2000† DF-G2 1200 DF-G1 740 D10A 350	PIT43TMB5

Diffuse Fibers



End Tip	Features	Minimum Bend Radius	Core Diameter	Free Cut	Typical Range (mm)	Models
	Thread Stainless Steel Braid over monocoil	12 mm	1 mm	-	DF-G3 1780 DF-G2 370 DF-G1 230 D10A 80	PBT43TMB5
	Coaxial Thread Stainless Steel Braid over monocoil	12 mm	1 x 0.5 & 9 x 0.25 mm	-	DF-G3 855 DF-G2 180 DF-G1 110 D10A 40	PBCT23TMB5
	Coaxial Threaded right angle Stainless Steel Braid over monocoil	12 mm	1 x 0.5 & 9 x 0.25 mm	-	DF-G3 620 DF-G2 130 DF-G1 80 D10A 30	PBCT23TMB5MTA
	Coaxial Thread Stainless Steel Braid over monocoil	12 mm	1 x 0.5 & 9 x 0.25 mm	-	DF-G3 855 DF-G2 180 DF-G1 110 D10A 40	PBCT23TMB5M4
	Threaded right angle Stainless Steel Braid over monocoil	12 mm	1 mm	-	DF-G3 1630 DF-G2 340 DF-G1 210 D10A 80	PBAT43TMB5MTA

† Max range determined by cable length 1 m = 2,000 (does not apply to diffuse models)

DURA-BEND™ Fibers

DURA-BEND™ fiber models provide improved flexibility for limited space setups and difficult-to-access locations. These fibers are best for use when fibers need to be integrated into a small fixture where a great deal of bending in tight spaces is needed.

- Minimal transmission loss under extreme bend radius
- Maintains performance regardless of flexing
- Multicore assemblies available
- Can almost kink fiber without affecting performance
- Works well in constant flexing applications
- Opposed models come as a pair



Opposed Fibers



End Tip	Features	Minimum Bend Radius	Core Diameter	Free Cut	Typical Range (mm)	Models
	M4 x 0.7 and M2.5 x 0.45 Thread	2 mm	1 mm		DF-G3 3420 DF-G2 715 DF-G1 440 D10A 230	PIT46UHF
	Smooth ferrule	2 mm	1 mm		DF-G3 3420 DF-G2 715 DF-G1 440 D10A 230	PIF46UHF
	Thread	1 mm	0.5 mm		DF-G3 930 DF-G2 195 DF-G1 120 D10A 65	PIT26UHF
	Smooth ferrule	2 mm	1 mm		DF-G3 3420 DF-G2 710 DF-G1 440 D10A 230	PIFM46UHF
	Right angle Low profile	2 mm	1 mm		DF-G3 3110 DF-G2 650 DF-G1 400 D10A 200	PIA46UHFBMPMS
	Right angle Threaded	2 mm	1 mm		DF-G3 3420 DF-G2 710 DF-G1 440 D10A 330	PIAT46UHFMFTA

Diffuse Fibers



End Tip	Features	Minimum Bend Radius	Core Diameter	Free Cut	Typical Range (mm)	Models
	Thread	1 mm	0.5 mm		DF-G3 310 DF-G2 65 DF-G1 40 D10A 18	PBT26UHF
	Thread	2 mm	1 mm		DF-G3 1090 DF-G2 230 DF-G1 140 D10A 70	PBT46UHF
	Right Angle Threaded	2 mm	1 mm		DF-G3 930 DF-G2 195 DF-G1 120 D10A 70	PBAT46UHFMFTA

High Temp Fibers

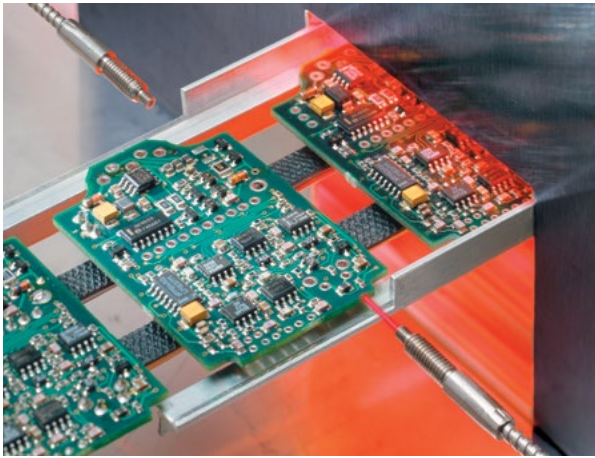

High temp fiber optics are used in situations where the temperature is above a certain limit for most plastic fibers. These are usually used in thermal process applications and Banner offers the widest selection of plastic and glass fibers for high temperature situations.

- For high temp applications above 100° C
- Thermal process applications
- For sensing near manufacturing ovens
- Manufacturing of solar panels, colored glass and ceramics
- Widest selection of plastic and glass fibers for high temp applications



Opposed Fibers

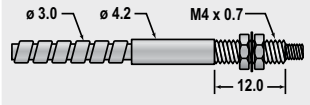
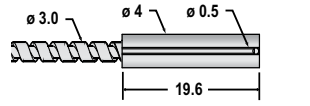
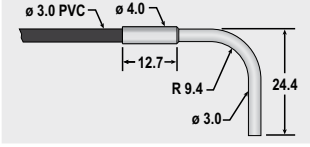
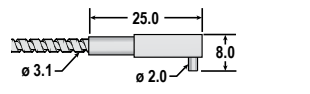
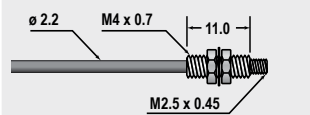



End Tip	Features	Minimum Bend Radius	Core Diameter	Free Cut	Typical Range (mm)	Models
	M2.5 x 0.45 thread Stainless Steel Sheath End tip withstands 315° C	19 mm	1.2 mm	–	DF-G3 4000† DF-G2 1260 DF-G1 775 D10A 325	IMT.756.6S-HT
	Smooth ferrule Side exit Stainless steel 250° C	19 mm	0.5 mm	–	DF-G3 1320 DF-G2 275 DF-G1 170 D10A 53	IA.31.7ST5ETA
	Smooth ferrule 90° angle Stainless steel tip End tip withstands 105° C	19 mm	1.3 mm	–	DF-G3 4000† DF-G2 1310 DF-G1 810 D10A 310	IA.82.5PT5
	Smooth ferrule Side exit Stainless steel 480° C	19 mm	1.3 mm	–	DF-G3 4000† DF-G2 1310 DF-G1 810 D10A 300	IA.83.3ST5ETA
	Thread End tip withstands 105° C	15 mm	1 mm		DF-G3 4000† DF-G2 960 DF-G1 600 D10A 210	PIT46UHT1

† Max range determined by cable length 2 m = 4,000

Diffuse Fibers

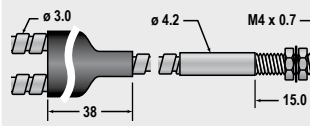
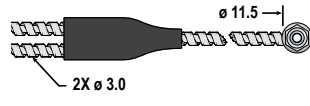
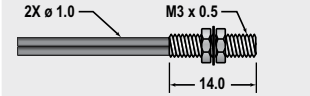

End Tip	Features	Minimum Bend Radius	Core Diameter	Free Cut	Typical Range (mm)	Models
	Miniature thread Stainless Steel Sheathing End tip withstands 315° C	19 mm	1.6 mm	–	DF-G3 390 DF-G2 80 DF-G1 50 D10A 15	BMT16.6S-HT
	Thread right angle Stainless Steel Sheathing End tip withstands 250° C	12 mm	1.6 mm	–	DF-G3 2100 DF-G2 440 DF-G1 270 D10A NA	BAT16.6ST5MTA
	Thread End tip withstands 105° C	15 mm	0.5 mm		DF-G3 390 DF-G2 80 DF-G1 50 D10A 20	PBT26UHT2

Specialty Fibers

Specialty and custom fibers are designed for specific sensing applications. Many of the standard fibers can be customized and ready for use in days, not weeks. Banner excels in customization and will work with you to find the right solution.

- Chemical resistance
- Extreme environments
- Liquid level detection
- Customize bifurcations, material, lengths and other fiber features

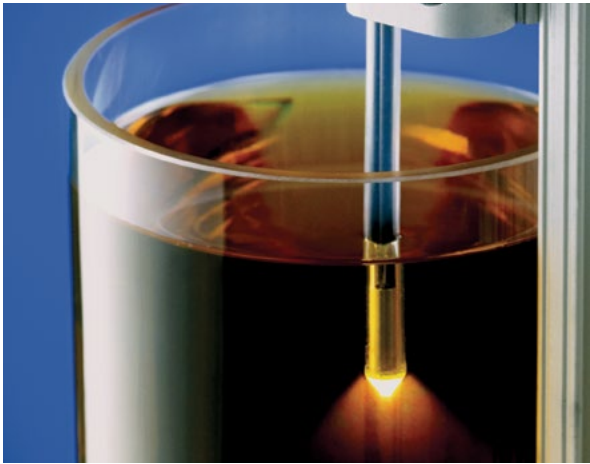

Liquid Level Fibers

End Tip	Features	Minimum Bend Radius	Core Diameter	Free Cut	Typical Range (mm)	Models
	Fluoropolymer encapsulated Sensor switches when tip of fiber is immersed in liquid	25 mm	1 mm		DF-G3 DF-G2 DF-G1 D10A	NA PBE46UTMLLP
	Fluoropolymer encapsulated Sensor switches when tip of fiber is immersed in liquid End tip withstands 105° C	15 mm	1 mm		DF-G3 DF-G2 DF-G1 D10A	NA PBE46UTMLLPHT1
	Clear tube mount, 2 to 25 mm diameter	2 mm	1 mm		Sensor switches when liquid meniscus reaches optical axis	 PDI46U-LLD

Diffuse Fibers



End Tip	Features	Minimum Bend Radius	Core Diameter	Free Cut	Typical Range (mm)	Models
	Coaxial ferrule probe Non-metallic end tip	25 mm	1 x 1.0 & 16 x 0.25 mm		DF-G3 1710 DF-G2 360 DF-G1 220 D10A 120	 PBCFP46UMLR
	Fluoropolymer encapsulated tip	25 mm	1 mm		DF-G3 1710 DF-G2 360 DF-G1 220 D10A 12	 PBE46UTMNL
	Dual bifurcated Light "OR" or Dark "AND" logic	15 mm	0.5 mm	-	DF-G3 DF-G2 DF-G1 D10A	NA PDBF26T5

Opposed Fibers



End Tip	Features	Minimum Bend Radius	Core Diameter	Free Cut	Typical Range (mm)	Models
	Specialty slot sensor 90° angle; compact "fork" head	2 mm	1 mm		DF-G3 5 DF-G2 5 DF-G1 5 D10A 5	PDISM46UM5MA
	Sold as a pair Fluoropolymer encapsulated; lens	25 mm	1 mm		DF-G3 4000† DF-G2 3080 DF-G1 1900 D10A 1600	PIE46UT
	Sold as a pair Fluoropolymer encapsulated; lens	40 mm	1.5 mm		DF-G3 4000† DF-G2 1540 DF-G1 950 D10A 300	PIE66UTMNL
	Sold as a pair Fluoropolymer encapsulated; Side-view prism	25 mm	1 mm		DF-G3 400 DF-G2 280 DF-G1 280 D10A 280	PIES46UT
	Sold as a pair Flat sides for easy alignment Brass housing	40 mm	1.5 mm		DF-G3 4000† DF-G2 1100 DF-G1 680 D10A 350	PIPS66UMSQMAP

Vacuum Applications

End Tip	Features	Minimum Bend Radius	Core Diameter	Free Cut	Typical Range (mm)	Models
	Vacuum compatible No epoxy	19 mm	1.6 mm	-	Varies by feed through and amp used	BMT13SMVF
	Aluminum Vacuum feed through	-	-	-	DF-G3 NA DF-G2 NA DF-G1 NA D10A NA	DVFT-2.ONWQ50
	Miniature thread No epoxy used For use on vacuum side Entire cable withstands 480 °C	19 mm	1.2 mm	-	Varies by feed through and amp used	IMT.753SMVF
	For use with Vacuum feed through on ambient side Opposed mode sold as a pair	40 mm	1.5 mm		DF-G3 4000† DF-G2 2140 DF-G1 1320 D10A 350	PIF66UMVFA
	Stainless steel Vacuum feed through	-	-	-	DF-G3 NA DF-G2 NA DF-G1 NA D10A NA	VFT-M8MVS

† Max range determined by cable length 2 m = 4,000

Standard Fibers











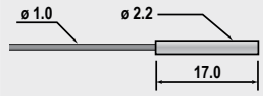

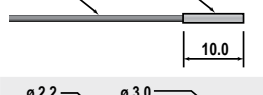
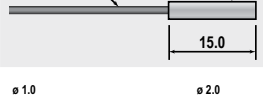

Standard fiber optics come in a variety of materials with standard fiber tips in various sizes. If a standard fiber does not meet your application requirements, modifications can be made to give you a customized solution.

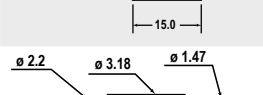
- Plastic individual fibers ideal for use in small, confined areas
- Available in side view/right angles
- Available in bifurcated models
- Opposed models come as a pair

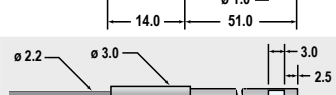

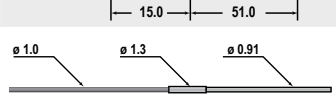
Opposed Fibers

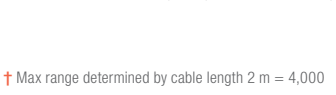

End Tip	Features	Minimum Bend Radius	Core Diameter	Free Cut	Typical Range (mm)	Models
	Smooth ferrule Stainless steel tip	15 mm	0.5 mm		DF-G3 1710 DF-G2 355 DF-G1 220 D10A 75	PIF26U
	Smooth ferrule Stainless steel tip	25 mm	1 mm		DF-G3 4000† DF-G2 1330 DF-G1 820 D10A 300	PIF46U
	Smooth ferrule Stainless steel tip	40 mm	1.5 mm		DF-G3 4000† DF-G2 2140 DF-G1 1320 D10A 525	PIF66U
	Stainless steel tip Best for repetitive flexing (1,000s of cycles)	5 mm	4 x 0.25 mm		DF-G3 1940 DF-G2 405 DF-G1 250 D10A 70	PIFM1X46U
	Smooth ferrule Stainless steel tip	25 mm	1 mm		DF-G3 4000† DF-G2 1330 DF-G1 820 D10A 300	PIFM46U
	Smooth ferrule Stainless steel tip	5 mm	0.25 mm		DF-G3 505 DF-G2 105 DF-G1 65 D10A 20	PIF16U
	Smooth ferrule Stainless steel tip Thick jacket (ø 2.2 mm)	15 mm	0.5 mm		DF-G3 1710 DF-G2 355 DF-G1 220 D10A 80	PIF26UMLS
	Smooth ferrule Stainless steel tip 90° angle sideview	25 mm	1 mm		DF-G3 2720 DF-G2 565 DF-G1 350 D10A 160	PIPS46U
	Smooth ferrule Stainless steel tip 90° angle sideview	40 mm	1.5 mm		DF-G3 2950 DF-G2 615 DF-G1 380 D10A 350	PIPS66U
	Probe Stainless steel tip	5 mm	0.5 mm		DF-G3 505 DF-G2 105 DF-G1 65 D10A 20	PIP16U

† Max range determined by cable length 2 m = 4,000

Opposed Fibers



End Tip	Features	Minimum Bend Radius	Core Diameter	Free Cut	Typical Range (mm)	Models
	Probe Stainless steel tip	15 mm	0.5 mm		DF-G3 1825 DF-G2 380 DF-G1 235 D10A 80	PIP26U
	Probe Stainless steel tip	25 mm	1 mm		DF-G3 4000† DF-G2 1230 DF-G1 760 D10A 265	PIP46U
	Stainless steel threaded tip	5 mm	0.25 mm		DF-G3 465 DF-G2 100 DF-G1 60 D10A 15	PIT16U
	Nickel plated brass threaded tip	15 mm	0.5 mm		DF-G3 1710 DF-G2 220 DF-G1 75 D10A	PIT26U
	Nickel plated brass threaded tip	25 mm	1 mm		DF-G3 4000† DF-G2 1120 DF-G1 690 D10A 240	PIT415U
	Nickel plated brass threaded tip	25 mm	1 mm		DF-G3 4000† DF-G2 1330 DF-G1 820 D10A 300	PIT46U
	Nickel plated brass threaded tip	40 mm	1.5 mm		DF-G3 4000† DF-G2 2140 DF-G1 1320 D10A 525	PIT66U
	Nickel plated brass threaded tip	40 mm	1.5 mm		DF-G3 4000 DF-G2 1815 DF-G1 1120 D10A 450	PIT615U
	Stainless steel 90° angle tip	5 mm	0.25 mm		DF-G3 230 DF-G2 50 DF-G1 30 D10A 15	PIA16U
	Stainless steel 90° angle tip	15 mm	0.5 mm		DF-G3 930 DF-G2 195 DF-G1 120 D10A 50	PIA26U
	Nickel plated brass threaded 90° angle tip	5 mm	0.25 mm		DF-G3 465 DF-G2 100 DF-G1 60 D10A 10	PIAT16U
	Nickel plated brass threaded 90° angle tip	15 mm	0.5 mm		DF-G3 1555 DF-G2 325 DF-G1 200 D10A 50	PIAT26U

† Max range determined by cable length 2 m = 4,000

Opposed Fibers



End Tip	Features	Minimum Bend Radius	Core Diameter	Free Cut	Typical Range (mm)	Models
	Stainless steel threaded 90° angle tip	25 mm	1 mm	✂	DF-G3 4000† DF-G2 1360 DF-G1 840 D10A 275	PIAT46U
	Stainless steel threaded 90° angle tip	40 mm	1.5 mm	✂	DF-G3 4000† DF-G2 2075 DF-G1 1280 D10A 350	PIAT66U
	Stainless steel threaded 90° angle tip	25 mm	1 mm	✂	DF-G3 4000† DF-G2 1360 DF-G1 840 D10A 275	PIAT46UM.4X.4MT
	Stainless steel threaded 90° angle tip	2 mm	1 mm	✂	DF-G3 4000† DF-G2 970 DF-G1 600 D10A 210	PIAT46UHF
	Delrin side exit	2 mm	1 mm	✂	DF-G3 2000† DF-G2 710 DF-G1 440 D10A 230	PIA46UHFMB8X12

† Max range determined by cable length 2 m = 4,000

Diffuse Fibers



End Tip	Features	Minimum Bend Radius	Core Diameter	Free Cut	Typical Range (mm)	Models
	Smooth ferrule Stainless steel tip	15 mm	0.5 mm	✂	DF-G3 620 DF-G2 130 DF-G1 80 D10A 25	PBF26U
	Smooth ferrule Stainless steel tip	25 mm	1 mm	✂	DF-G3 1710 DF-G2 355 DF-G1 220 D10A 85	PBF46U
	Smooth ferrule Stainless steel tip Thin jacket (ø 1.3)	25 mm	1 mm	✂	DF-G3 1710 DF-G2 355 DF-G1 220 D10A 85	PBF46UM3MJ1.3
	Smooth ferrule Stainless steel tip	40 mm	1.5 mm	✂	DF-G3 2410 DF-G2 500 DF-G1 310 D10A 170	PBF66U
	Smooth ferrule Stainless steel tip	2 mm	1 mm	✂	DF-G3 1445 DF-G2 300 DF-G1 186 D10A 65	PBF46UHF
	Smooth ferrule Stainless steel tip Coaxial	5 mm	1 x 1.0 and 16 x 0.25 mm	✂	DF-G3 2140 DF-G2 445 DF-G1 275 D10A 96	PBCF46U
	Smooth ferrule Stainless steel tip	15 mm	0.5 mm	✂	DF-G3 175 DF-G2 160 DF-G1 100 D10A 35	PBEFP26U
	Smooth ferrule Stainless steel tip	25 mm	1 mm	✂	DF-G3 1980 DF-G2 410 DF-G1 255 D10A 90	PBFM46U
	Smooth ferrule Stainless steel tip	2 mm	1 mm	✂	DF-G3 1440 DF-G2 300 DF-G1 185 D10A 65	PBFM46UHF
	Smooth ferrule Stainless steel tip	5 mm	0.25 mm	✂	DF-G3 4000† DF-G2 1120 DF-G1 690 D10A 240	PBFMP16UMP.2
	Smooth ferrule Stainless steel tip 90° angle sideview	15 mm	0.5 mm	✂	DF-G3 230 DF-G2 50 DF-G1 30 D10A 15	PBPS26U
	Smooth ferrule Stainless steel tip 90° angle sideview	25 mm	1 mm	✂	DF-G3 275 DF-G2 160 DF-G1 100 D10A 50	PBPS46U
	Probe ferrule Stainless steel tip	15 mm	0.5 mm	✂	DF-G3 545 DF-G2 115 DF-G1 70 D10A 30	PBPF215U
	Probe ferrule Bendable stainless steel tip	15 mm	0.5 mm	✂	DF-G3 620 DF-G2 130 DF-G1 80 D10A 25	PBP26U

Diffuse Fibers



End Tip	Features	Minimum Bend Radius	Core Diameter	Free Cut	Typical Range (mm)	Models
	Probe ferrule Bendable stainless steel tip	25 mm	1 mm	✂	DF-G3 1710 DF-G2 355 DF-G1 220 D10A 85	PBP46U
	Probe ferrule Stainless steel tip	5 mm	0.25 mm	✂	DF-G3 155 DF-G2 30 DF-G1 20 D10A 10	PBFM16U
	Probe ferrule Bendable stainless steel tip	5 mm	0.25 mm	✂	DF-G3 115 DF-G2 25 DF-G1 15 D10A 5	PBP16U
	Probe ferrule Bendable stainless steel tip	2 mm	1 mm	✂	DF-G3 1475 DF-G2 310 DF-G1 190 D10A 65	PBP46UHF
	Probe ferrule Stainless steel tip	15 mm	0.5 mmv	✂	DF-G3 620 DF-G2 130 DF-G1 80 D10A 25	PBPF26U
	Coaxial Threaded Stainless steel tip	5 mm	1 x 0.5 & 9 x 0.25 mm	✂	DF-G3 700 DF-G2 145 DF-G1 90 D10A 40	PBCT26U
	Coaxial Threaded Stainless steel tip	5 mm	1 x 0.5 & 9 x 0.25 mm	✂	DF-G3 700 DF-G2 145 DF-G1 90 D10A 40	PBCT26UM3
	Coaxial Threaded Stainless steel tip	5 mm	1 x 0.5 & 9 x 0.25 mm	✂	DF-G3 700 DF-G2 145 DF-G1 90 D10A 40	PBCT26UM4M2.5
	Coaxial Threaded Stainless steel tip Overmolded flex relief	15 mm	1 x 0.5 10 x 0.25 mm	✂	DF-G3 1555 DF-G2 325 DF-G1 200 D10A 110	PBCT26UMFR
	Coaxial Threaded Nickel plated Brass tip	5 mm	1 x 1.0 & 16 x 0.25 mm	✂	DF-G3 1710 DF-G2 355 DF-G1 220 D10A 120	PBCT46U
	Coaxial Threaded Stainless steel tip Overmolded flex relief	25 mm	1 x 1.0 16 x 0.25 mm	✂	DF-G3 1555 DF-G2 325 DF-G1 200 D10A 110	PBCT46UMFR
	Threaded Stainless steel tip	5 mm	0.25 mm	✂	DF-G3 80 DF-G2 15 DF-G1 10 D10A 5	PBT16U
	Threaded Nickel plated Brass tip	15 mm	0.5 mm	✂	DF-G3 620 DF-G2 130 DF-G1 80 D10A 25	PBT26U
	Stainless steel tip	12 mm	0.5 mm	✂	DF-G3 620 DF-G2 130 DF-G1 80 D10A 25	PBT26UMSSMFF

Diffuse Fibers



End Tip	Features	Minimum Bend Radius	Core Diameter	Free Cut	Typical Range (mm)	Models
	Threaded Nickel plated Brass tip	25 mm	1 mm		DF-G3 1710 DF-G2 355 DF-G1 220 D10A 85	PBT46U
	Threaded Nickel plated Brass tip	40 mm	1.5 mm		DF-G3 2400 DF-G2 500 DF-G1 310 D10A 170	PBT66U
	Threaded Nickel plated Brass tip	25 mm	1 mm		DF-G3 1400 DF-G2 290 DF-G1 180 D10A 70	PBT415U
	Threaded Nickel plated Brass tip	15 mm	0.5 mm		DF-G3 740 DF-G2 155 DF-G1 95 D10A 30	PBT26UM6M.1
	Stainless steel threaded 90° angle tip	25 mm	1 mm		DF-G3 930 DF-G2 195 DF-G1 120 D10A 70	PBAT46U
	10.9 mm front exit Aluminium	5 mm	32 x 0.25 mm		DF-G3 1555 DF-G2 325 DF-G1 200 D10A 65	PBR1X326U
	10.9 mm side exit Aluminium	5 mm	32 x 0.25 mm		DF-G3 1555 DF-G2 325 DF-G1 200 D10A 65	PBRs1X326U
	Dual lens straight exit Aluminium	25 mm	1 mm		DF-G3 4000† DF-G2 950 DF-G1 590 D10A 210	PBL46U

† Max range determined by cable length 2 m = 4,000

Plastic Fiber Optics Specifications

Construction	<p>Optical Fiber: Acrylic (PMMA) monofilament, except as noted Protective Jacket: Black polyethylene, except as noted Threaded End Tips and Hardware: Nickel-plated brass, except as noted Probe End Tips: Annealed (bendable) 304 stainless steel Angled End tips: Hardened 304 stainless steel Ferrule End Tips: 303 stainless steel</p>
Sensing Range	Refer to the specific fiber optic/sensor combination
Implied Dimensional Tolerance	All dimensions are in millimeters: x = ±2.5 mm, x.x = ±0.25 mm and x.xx = ±0.12 mm, unless specified "L" = ±40 mm per meter
Minimum Bend Radius	8 mm for 0.25 mm diameter fibers 12 mm for 0.5 mm diameter fibers (except DURA-BEND™) 25 mm for 1.0 mm diameter fibers (except DURA-BEND™) 38 mm for 1.5 mm diameter fibers
Repeat Bending/Flexing	Life expectancy of plastic fiber optic cable is in excess of one million cycles at bend radii of no less than the minimum and a bend of 90° or less. Avoid stress at the point where the cable enters the sensor ("control end") and at the sensing end tip. Coiled plastic fiber optic assemblies are recommended for any application requiring reciprocating fiber motion.
Chemical Resistance	The acrylic core of the monofilament optical fiber will be damaged by contact with acids, strong bases (alkalis) and solvents. The polyethylene jacket will protect the fiber from most chemical environments. However, materials may migrate through the jacket with long term exposure. Samples of fiber optic material are available from Banner for testing and evaluation.
Temperature Extremes	Temperatures below -30 °C will cause embrittlement of the plastic materials but will not cause transmission loss. Temperatures above +70 °C will cause both transmission loss and fiber shrinkage.
Operating Temperature	-30 to +70 °C, unless otherwise specified

Fiber Core Diameter Comparison

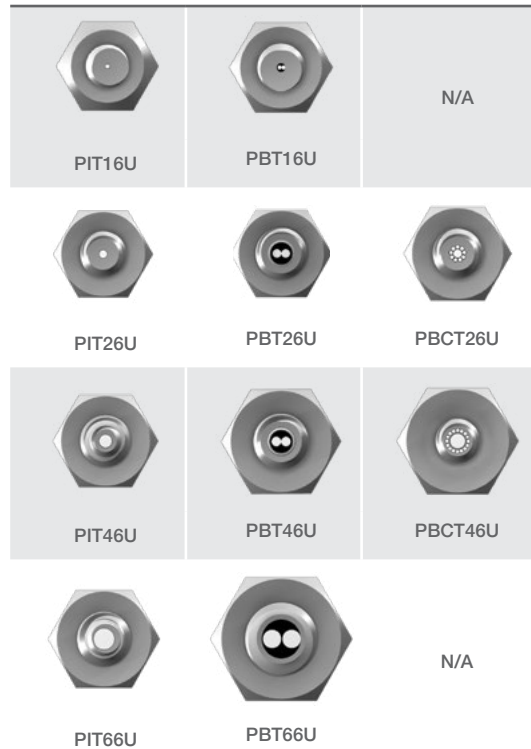

⚠ Application Notes and Warnings ⚠

- 1 Plastic fiber assemblies with "U" in the suffix of the model numbers have unterminated control ends (the end that is coupled to the photoelectric sensor). The customer can cut these fiber optic assemblies to the required length using the supplied cutter. Use only the supplied cutter to ensure optimal light coupling efficiency.
- 2 Terminated plastic fiber assemblies are optically ground and polished and cannot be shortened, spliced or otherwise modified.
- 3 Do not subject the plastic fibers to sharp bends, pinching, high tensile loads or high levels of radiation.
- 4 When ordering fiber lengths in excess of 2 m, take into account light signal attenuation due to the additional length.
- 5 Due to their light transmission properties, plastic fiber optics are recommended for use only with visible light fiber optic sensors.
- 6 Use caution when applying fiber optics in hazardous locations. Although fiber optic assemblies are, by themselves, intrinsically safe, the sensor and associated electronics must be LOCATED IN A SAFE ENVIRONMENT. Alternatively, fiber optics may be used with NAMUR sensor model Q45AD9FP. Fiber optics do not necessarily provide a hermetic seal between a hazardous environment and the safe environment.

Fiber Optic Accessories

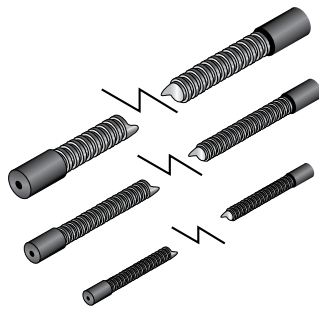
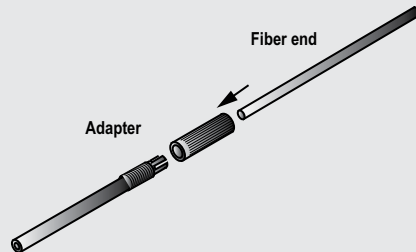
	Model Specific Features	General Features	Image	Model Number
Fiber Cutters	Plastic fiber cutter	single cutter	 <p>NOTE: Adaptors used with Q45, OMNI-BEAM, ECONO-BEAM, MAXI-BEAM and VALU-BEAM sensors only.</p>	PFC-4
		100 cutters		PFC-4-100
	For use with 0.25 and 0.5 mm diameter cables.	<ul style="list-style-type: none"> • These kits are used with unterminated plastic fiber cables • Each kit contains 40 sensor adaptors and 10 cutter assemblies 		PFK20
	For use with 1 and 1.5 mm diameter cables.			PFK40
Plastic Fiber Field-Installable Sheathing	May be used with bifurcated fiber assemblies having M6 x 0.75 threaded end tips (e.g., PBCT46U, PBP46U, PBT46UHT1 and PBT66U).	<ul style="list-style-type: none"> • Stainless steel sheathing with stainless steel end fittings (one end internally threaded to capture fiber end tips, other end non-threaded) is used in applications where protection is required for plastic fiber optic cables • All models listed are 1.8 m in length • Other lengths are available by contacting Banner Applications Department 		PFS69S6T
	May be used with individual or bifurcated fiber assemblies having M4 x 0.7 threaded end tips (e.g., PBCT26U, PBPF26U, PIP46U, PIT46U and PIT66U).			PFS53S6T
	May be used with individual fiber assemblies having M3 x 0.5 threaded end tips (e.g., PIP26U, PIT26U and PIT1X46U).			PFS44S6T
Plastic Fiber Adapters	Use to adapt plastic fiber optic cables with outside jacket diameter of 1.0 mm, such as PIT26U and PBP16U.	<ul style="list-style-type: none"> • Compression fitting adapters are used with small-diameter unterminated plastic fiber cables • Use when interfacing small-diameter plastic fibers to D10, D12, QM42, QS18, R55F, FI22 and MINI-BEAM plastic fiber sensor families • Each kit contains 100 pairs of adapters. One pair will interface either one bifurcated fiber optic cable or a pair of individual cables to a fiber optic amplifier 		UPFA-1-100
	Use to adapt plastic fiber optic cables with outside jacket diameter of 1.25 mm or 1.3 mm, such as PBCT26U and PBF46UM3MJ1.3.			UPFA-2-100

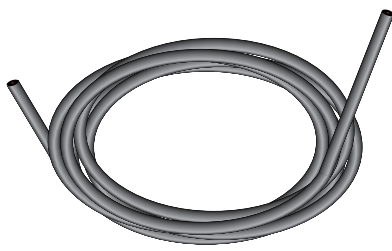
	Core	Length	Type	Drawing	Model Number
Unterminated Individual and Bifurcated Plastic Fibers	0.5 mm	9 m	Single		PIU230U
		18 m			PIU260U
	1.0 mm	9 m	Single		PIU430U
		18 m			PIU460U
	1.5 mm	9 m	Single		PIU630U
		18 m			PIU660U
	1.0 mm	9 m	Duplex		PBU430U
		18 m			PBU460U

Glass Fiber Optics

Solve numerous challenging sensing applications in the most hostile environments, including temperatures up to 480° C, corrosive materials and extreme moisture

- Withstand severe shock and vibration
- Ignore extreme electrical noise
- Constructed of a combination of optical glass fiber, stainless steel, PVC, brass, molded thermoplastics and optical-grade epoxy

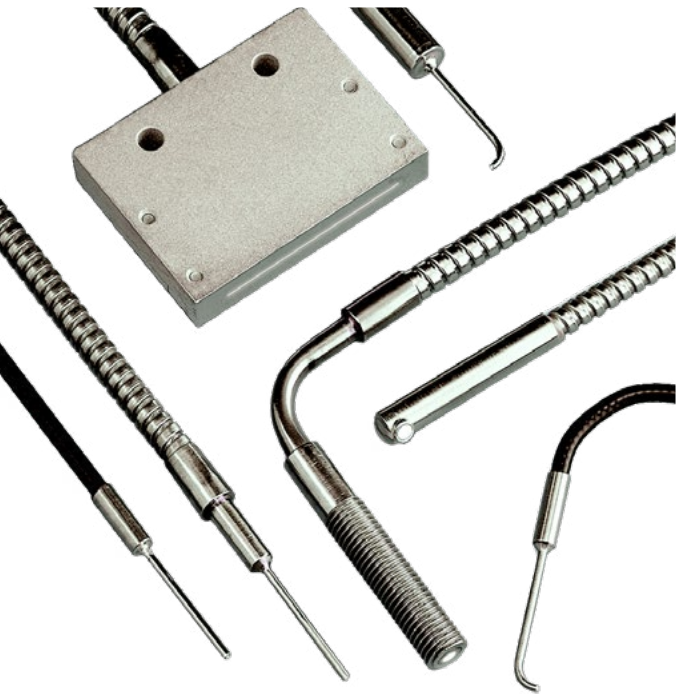

Choosing Glass or Plastic

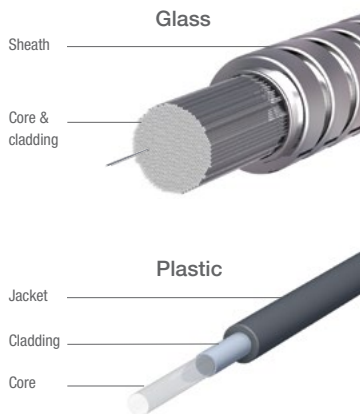

Fiber Construction

Core: Thin glass or plastic center of the fiber through which light travels

Cladding: Outer optical material surrounding the core that reflects light back into the core

Jacket/

Sheath: Protective layer to protect fiber from damage and moisture

Plastic fibers are for general purpose use. They tolerate severe flexing, can be cut to length in the field and cost less than glass fibers. Glass fibers are the best choice for challenging environments such as high temperatures, corrosive materials and moisture.



Glass fibers **page 192**

- Solve numerous challenging sensing requirements
- Ideal for hostile environments such as high temperatures to 480° C, corrosive materials and extreme moisture
- Withstand high levels of shock and vibration
- Inherently immune to extreme electrical noise
- Available with choice of sheathings: standard stainless-steel flexible conduit, PVC or other flexible tubing
- Can be quickly custom designed



Plastic fibers **page 174**

- Inexpensive and easily cut to length during installation
- Bend for a precise fit
- Available in high-flex models to withstand flexing
- Offered with special jackets that withstand corrosion, impact and abrasion
- Available for applications requiring articulated or reciprocating motion
- Available in diameters of 0.25, 0.5, 1.0 Or 1.5 mm
- Can be quickly custom designed and built for your unique applications

Model Key



ASSEMBLY STYLE

- B = Bifurcated fiber
- I = Individual fiber*

SENSING END TIP STYLE

- A = 90° Angle
- AM = Miniature 90° Angle
- AT = 90° Angle/Thread
- F = Ferrule
- M = Miniature Tip
- MP = Miniature Probe
- MT = Miniature Thread
- R = Rectangular Bundle Termination
- T = Thread
- TA = Thread/90° Angle
- TETA = Thread and Extra Tight 90° Angle

MODIFICATIONS

- "MXX" = Sensing end tip modification
- "M600" = Sensing end withstands 315° C
- "M900" = Sensing end withstands 480° C

SHEATHING MATERIAL

- S = Stainless steel flexible conduit
- P = PVC with galvanized monocoil reinforcing wire

OVERALL LENGTH (in feet)

- 2 = 2 ft. = 610 mm ±38 mm
- 3 = 3 ft. = 914 mm ±38 mm

FIBER BUNDLE DIAMETER

- .44 = 0.027 in = 0.69 mm
- .5 = 0.032 in = 0.81 mm
- .75 = 0.046 in = 1.17 mm
- 1 = 0.062 in = 1.57 mm
- 1.5 = 0.09 in = 2.29 mm
- 2 = 0.125 in = 3.18 mm
- 2.5 = 0.156 in = 3.96 mm

* Individual glass fibers are packaged separately.

Opposed Glass Fibers



End Tip	Features	Minimum Bend Radius	Core Diameter	Temp	Typical Range (mm)		Models
	90° angle	19 mm	3.18 mm	M600 M900	QS18 R55F SME312 D12E D12	715 1050 250 975 550	IA23S
	90° angle/thread Lenses available	19 mm	3.18 mm	M600 M900	QS18 R55F SME312 D12E D12	900 1050 250 975 550	IAT23S
	Smooth ferrule	19 mm	3.18 mm	M600 M900	QS18 R55F SME312 D12E D12	990 1050 975 550	IF23P
	Miniature thread	9.5 mm	0.69 mm		QS18 R55F SME312 D12E D12	NA 75 25 102 70	IMT.442P
	Thread Lenses available	19 mm	3.18 mm	M600 M900	QS18 R55F SME312 D12E D12	900 1050 250 975 550	IT23S
	90° angle/thread	19 mm	3.18 mm	M600 M900	QS18 R55F SME312 D12E D12	1100 1050 250 925 550	ITA23S
	Miniature probe 90° angle	19 mm	1.17 mm	M600	QS18 R55F SME312 D12E D12	110 130 50 180 170	IAM.752S
	Miniature probe Non-bendable probe	19 mm	1.17 mm	M600	QS18 R55F SME312 D12E D12	NA 130 50 180 170	IM.752S
	Miniature probe	9.5 mm	1.17 mm		QS18 R55F SME312 D12E D12	NA 130 50 180 170	IMP.753P

M600 Available 315 °C models. Add M600 to end of model number (example, IA23SM600).

M900 Available 480 °C models. Add M900 to end of model number (example, IA23SM900).
Dimensions may vary for these models.

NA: Not recommended.

Opposed Glass Fibers



End Tip	Features	Minimum Bend Radius	Core Diameter	Temp	Typical Range (mm)	Models
	Straight exit; 38 mm width	19 mm	3.7 mm	M600	QS18 760 R55F 1175 SME312 350 D12E 975 D12 580	IR2.53S
	Straight exit; 10 mm width	19 mm	3.2 mm	M600	QS18 1045 R55F 1050 SME312 250 D12E 925 D12 550	IR23S
	Side exit Stainless steel	19 mm	2.3 mm	M600	QS18 250 R55F 600 SME312 180 D12E 500 D12 450	IA1.53SMETA
	Side exit Stainless steel	19 mm	2.3 mm	M600	QS18 340 R55F 600 SME312 180 D12E 500 D12 450	IA1.53SMTA
	Side exit Stainless steel	19 mm	2.3 mm	M600	QS18 390 R55F 600 SME312 180 D12E 500 D12 450	ITETA1.53S
	For use in vacuum applications No epoxy	19 mm	1.3 mm		Contact factory for sensing range	IMT.753SMVF
	Glass lens withstands 315 °C Contact factory for range					L9
	Plastic housing withstands 105 °C Contact factory for range					L16F
	Aluminum housing withstands 315 °C Contact factory for range					L16FAL
	Stainless steel housing withstands 480 °C Contact factory for range					L16FSS

M600 Available 315 °C models. Add M600 to end of model number (example, BA23SM600).

Diffuse Glass Fibers

End Tip	Features	Minimum Bend Radius	Core Diameter	Temp	Typical Range (mm)		Models
	Stainless steel 90° angle	19 mm	3.2 mm	M600 M900	QS18 R55F SME312 D12E D12	80 110 25 180 150	BA23S
	Stainless Steel/Brass 90° angle	19 mm	3.2 mm	M600 M900	QS18 R55F SME312 D12E D12	90 110 25 180 150	BAT23S
	PVC sheath	19 mm	3.2 mm	-	QS18 R55F SME312 D12E D12	100 110 25 180 150	BF23P
	PVC over Moncoil Sheathing Brass	9.5 mm	0.7 mm	-	QS18 R55F SME312 D12E D12	NA NA 1 10 5	BMT.442P
	Stainless Steel/Brass	19 mm	3.2 mm	M600 M900	QS18 R55F SME312 D12E D12	100 110 25 180 150	BT23S
	Stainless steel/Brass 90° angle	19 mm	3.2 mm	M600 M900	QS18 R55F SME312 D12E D12	85 110 25 180 150	BTA23S
	Stainless Steel 90° angle	19 mm	1.2 mm	M600	QS18 R55F SME312 D12E D12	NA 11 3 42 25	BAM.752S
	Stainless Steel Probe	19 mm	1.2 mm	M600	QS18 R55F SME312 D12E D12	NA 11 3 42 25	BM.752S
	PVC over Moncoil Sheathing Probe	9.5 mm	1.2 mm	-	QS18 R55F SME312 D12E D12	NA 11 3 42 25	BMP.753P

M600 Available 315 °C models. Add w to end of model number (example, BA23SM600).

M900 Available 480° C models. Add M900 to end of model number (example, BA23SM900).
Dimensions may vary for these models.

NA: Not recommended.

Diffuse Glass Fibers

End Tip	Features	Minimum Bend Radius	Core Diameter	Temp	Typical Range (mm)		Models
	Straight exit; 38 mm width	19 mm	3.7 mm	M600	QS18 R55F SME312 D12E D12	75 120 30 180 155	BR2.53S
	Straight exit; 9.7 mm width	19 mm	3.2 mm	M600	QS18 R55F SME312 D12E D12	110 110 25 180 150	BR23S
	90° angle	19 mm	2.3 mm	M600	QS18 R55F SME312 D12E D12	45 65 20 135 125	BA1.53SMETA
	90° angle	19 mm	2.3 mm	M600	QS18 R55F SME312 D12E D12	50 60 20 135 125	BA1.53SMTA
	90° angle	19 mm	2.3 mm	M600	QS18 R55F SME312 D12E D12	30 60 20 135 125	BTETA1.53S
	Glass lens; withstands 315 °C Focuses light to .80 mm with ø 1.6 mm fiber						Contact factory for range information

M600 Available 315 °C models. Add M600 to end of model number (example, BA23SM600).

Glass Fiber Optics Specifications

Construction	Combination of optical glass fiber, stainless steel or PVC, brass, molded thermoplastics, and optical-grade epoxy. Optical fiber is F2 core, EN1 clad, approx. 50 μm diameter per strand. Flexible steel interlock sheathing is 302 stainless.
Sensing Range	Refer to the specific fiber optic to be used
Bend Radius	Inside bend radius must be 12 mm or greater for PVC covered fiber optic assemblies, and 25 mm or greater for stainless steel armored cable covered fibers
Length	Standard length for assemblies is 915 mm; see dimension diagrams Most models are available from the factory with shorter or longer cable lengths, up to 18 m max
Length Dimension Tolerance	Overall assembly length: ± 12 mm per 300 mm of length Shrink junction dimensions: ± 12 mm
Implied Dimensional Tolerances	All dimensions are in millimeters: x = ± 2.5 mm, x.x = ± 0.25 mm and x.xx = ± 0.12 mm, unless specified.
Operating Conditions	Fiber assemblies with stainless-steel (SS) sheathing and metal end tips: -140° to $+249^{\circ}$ C Fiber assemblies with PVC sheathing and/or plastic end tips: -40° to $+105^{\circ}$ C Special order assemblies with SS sheathing and metal end tips and model suffix "M600": -140° to $+315^{\circ}$ C* Special order assemblies with SS sheathing and metal end tips and model suffix "M900": -140° to $+480^{\circ}$ C*; note dimensional changes from STD models * sensing end tip only

▲ Application Notes and Warnings ▲

- 1** The ends of glass fiber optic assemblies are optically ground and polished. Care taken in this manufacturing process accounts for the light coupling efficiency of the fiber optic assembly. As a result, glass fiber assemblies cannot be shortened, spliced or otherwise modified.
- 2** Use caution when applying fiber optics in hazardous locations. Although fiber optic assemblies are by themselves, intrinsically safe, the sensor and associated electronics must be LOCATED IN A SAFE ENVIRONMENT. Alternatively, fiber optics may be used with sensor model SMI912FQD. This sensor is approved for use inside hazardous areas when used with an appropriate intrinsic barrier. Also, see NAMUR sensor models Q45AD9F and MIAD9F. Fiber optics do not necessarily provide a hermetic seal between a hazardous environment and the safe environment.
- 3** In applications where glass fibers are used to insulate the control from high voltage, specify silicone rubber, Teflon®, or high-density polyethylene sheathing with no reinforcing wire in the cable. It is the responsibility of the user to test each fiber optic assembly for insulation capacity.
- 4** Do not subject the fibers to sharp bends, pinching, repeated flexing or high levels of radiation.
- 5** When ordering fiber lengths in excess of 1 m, take into account light signal reduction of 5 percent per 300 mm of additional length.

Teflon® is a registered trademark of Dupont™.

Additional Models Available

In addition to the configurations shown, Banner offers thousands of readily available alternative fiber models:

- Substitute PVC over monocoil sheathing for stainless steel
- Reduce or increase glass fiber optic bundle diameters
Example: Change \varnothing 3.18 mm bundle to \varnothing 1.57 mm
- Substitute a rectangular-shaped fiber bundle (0.5 x 2.5 mm) for a circular bundle
- Change endtip material from brass to stainless steel
- Modify straight or angled probe tip dimensions
- Modify overall fiber length in intervals of 305 mm (standard lengths are 914 and 610 mm)



Measurement

High-quality optical, ultrasonic, radar and measuring array sensors help to solve the most challenging measurement applications.

MEASUREMENT

LASER page 202

ULTRASONIC page 216

RADAR page 240

ARRAYS page 246

TEMPERATURE &
VIBRATION page 260



Laser

Laser distance measurement sensors provide accurate non-contact measuring and monitoring of targets with varying color, shape and temperature.

Series	Description	Max Sensing Range	Dimensions H x W x D	Resolution	Housing Material	Power Supply
	LTF High-performance LTF Series Sensors detect targets regardless of color, material or sheen from up to 12 m away, straight-on or at an angle page 204	12 m	77 x 26 x 56 mm	0.3 to 3 mm	Die-cast zinc	12 to 30 V dc
	LE A laser sensor with a range of 100 up to 1000 mm right out of the box with 2-line LCD display easy adjustment, setup and use. page 206	1 m	60 x 26 x 56 mm	0.02 to 1.0 mm	Die-cast zinc	12 to 30 V dc
	LH High-precision laser measurement page 208	200 mm	80 x 33 x 65 mm	0.001 to 0.01 mm	Aluminum	18 to 30 V dc
	LG High-precision short-range laser measurement page 210	125 mm	55.3 x 20.2 x 82.3 mm	0.003 to 0.01 mm	Zinc alloy die-cast, plated and painted finish	12 to 30 V dc
	LT3 Time-of-flight laser distance-gauging page 212	Diffuse: 5 m Retro: 50 m	68.5 x 35.3 x 87 mm	1.0 to 1.25 mm	ABS	12 to 24 V dc
	LT7 Time-of-flight laser distance-gauging page 214	Diffuse: 10 m Retro: 250 m	93 x 42 x 95 mm	4.0 to 8.0 mm	ABS	18 to 30 V dc

OTHER AVAILABLE MODELS



Q4X page 34



Q50 Website Only

LTF Series

High-Performance Laser Time of Flight



- Best in class combination of range, repeatability and accuracy enable highly reliable target detection and precise distance measurement
- Two-line, eight-character display and push-button programming for easy setup, troubleshooting and real-time distance measuring
- Durable IP67 housing, high ambient light immunity and stable performance across temperatures provide reliable performance in challenging environments
- Advanced options, including delay timers, advanced triggered measurement modes and cross-talk avoidance

LTF

Example Model Number: LTF12IC2LDQ

Family	Range (m)	Output	Laser Class	Sensing Mode	Connector
LTF	12	I	C2	LD	Q
	12 24	I = 4 to 20 mA analog and (1) NPN/PNP discrete U = 0 to 10 V analog and (1) NPN/PNP discrete K = Dual Discrete with IO-Link	C2 = Class 2	LD = Laser diffuse	Blank = 2 m Integral Cable Q = Rotatable M12 Euro QD QP = PVC M12 Euro Pigtail QD W/30 = 9 m intergal cable
		NOTE: Discrete NPN/PNP is user configurable			



 Connection Option: A model with a QD requires a mating cordset.

M12/Euro-Style with Shield
Straight connector models listed; for right-angle, add **RA** to the end of the model number (example, **MQDEC2-506RA**)



5-Pin
MQDEC2-506
2 m (6.5')
MQDEC2-515
5 m (15')
MQDEC2-530
9 m (30')

Additional cordset information is available
See page 758



SMBLTFL



SMBLTFU



SMBAMSSLTFP



SMBLFFFA

includes 3/8" bolt for mounting

SMBLFFAM10

includes 10 mm bolt for mounting

SMBLFFAM12

clamps directly onto industry standard bracket systems of 1/2" or 12 mm rods

Additional bracket information is available
See page 724

LTF Specifications

Supply Voltage and Current	12 to 30 V dc																				
Normal Run Mode:	< 2.1 W. Current consumption < 85 mA at 24 V dc																				
Sensing Beam	Visible red laser; class 2																				
Beam Spot Size	<table border="1"> <thead> <tr> <th>Distance (mm)</th> <th>Size</th> </tr> </thead> <tbody> <tr> <td>50</td> <td>6.5 mm</td> </tr> <tr> <td>7500</td> <td>10 mm</td> </tr> <tr> <td>12000</td> <td>12.5 mm</td> </tr> </tbody> </table>	Distance (mm)	Size	50	6.5 mm	7500	10 mm	12000	12.5 mm												
Distance (mm)	Size																				
50	6.5 mm																				
7500	10 mm																				
12000	12.5 mm																				
Response Time	Fast: 1.5 ms Standard: 8 ms Medium: 32 ms Slow: 256 ms																				
Range and Linearity / Accuracy	<table border="1"> <thead> <tr> <th colspan="4">Accuracy</th> </tr> <tr> <th>Reflectance</th> <th></th> <th>±10 mm</th> <th>±20 mm</th> </tr> </thead> <tbody> <tr> <td>6% Black Card</td> <td></td> <td>5 m</td> <td>7 m</td> </tr> <tr> <td>18% Gray Card</td> <td></td> <td>8 m</td> <td>11 m</td> </tr> <tr> <td>90% White Card</td> <td></td> <td>12 m</td> <td>-</td> </tr> </tbody> </table>	Accuracy				Reflectance		±10 mm	±20 mm	6% Black Card		5 m	7 m	18% Gray Card		8 m	11 m	90% White Card		12 m	-
Accuracy																					
Reflectance		±10 mm	±20 mm																		
6% Black Card		5 m	7 m																		
18% Gray Card		8 m	11 m																		
90% White Card		12 m	-																		
Repeatability Slow 256 ms shown (for more info see datasheet)																					
Resolution	< 0.3 to 3 mm*																				
Construction	Die-cast zinc housing; acrylic window																				
Environmental Rating	IEC IP67; NEMA 6																				
Connections	5-Pin Threaded M12/Euro-Style Cordsets— with Shield																				
Operating Conditions	Temperature: -20 to +55 °C Humidity: 90% at +55 °C maximum relative humidity (non-condensing)																				
Certifications																					

* Resolution measured as twice repeatability with white target at slow response speed at 20 °C. See repeatability curves for more detail.

LE Series

Laser Sensor



- The LE laser sensors are ready to measure right out of the box with easy adjustment, setup and use.
- Easy adjustment with a two-line, eight-character intuitive display
- Repeatability and accuracy for challenging targets, from metal to black rubber
- Visible class 2 laser for small spot size and simple alignment

LE

Example Model Number: LE550IQ

Family	Range	Output	Laser Class	Connector
LE	550	I	Blank	Q
	550 = 100-1000 mm 250 = 100-400 mm	I = 4 to 20 mA analog and (1) NPN/PNP discrete U = 0 to 10 V analog and (1) NPN/PNP discrete D = (2) NPN/PNP discrete K = Dual Discrete with IO-Link	Blank = Class 2 C1 = Class1	Blank = 2 m Integral Cable Q = Rotatable M12 Euro QD QP = PVC M12 Euro Pigtail QD W/30 = 9 m Integral Cable

NOTE: Discrete NPN/PNP is user configurable

 Connection Option: A model with a QD requires a mating cordset.

M12/Euro-Style with Shield

Straight connector models listed; for right-angle, add **RA** to the end of the model number (example, **MQDEC2-506RA**)



5-Pin

MQDEC2-506
2 m (6.5')
MQDEC2-515
5 m (15')
MQDEC2-530
9 m (30')



SMBLEU **SMBLEL** **SMBLEFA**

Additional bracket information is available
See page 724



RWAMSLE
replacement windows

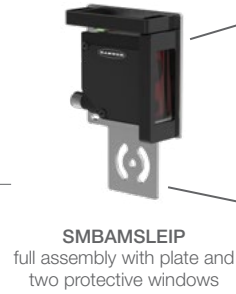

SMBAMSLEIP
full assembly with plate and two protective windows

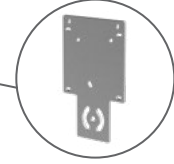

SMBAMSLTFP
mounting plate

Additional cordset information is available
See page 758



LE Specifications

Sensing Beam	Visible red Class 2 laser, 650 nm																																																		
Supply Voltage and Current	12 to 30 V dc Normal Run Mode: 1.7 W, Current consumption less than 70 mA at 24 V dc																																																		
Supply Protection Circuitry	Protected against reverse polarity and transient over voltages																																																		
Spot Size	<div style="display: flex; align-items: center;"> <table border="1" style="margin-right: 20px;"> <thead> <tr> <th colspan="5">LE550 Models</th> </tr> <tr> <th colspan="2"></th> <th colspan="3">Distance</th> </tr> <tr> <th colspan="2"></th> <th>100 mm</th> <th>550 mm</th> <th>1000 mm</th> </tr> </thead> <tbody> <tr> <td>X</td> <td></td> <td>8.4 mm</td> <td>10.5 mm</td> <td>12.1 mm</td> </tr> <tr> <td>Y</td> <td></td> <td>3.5 mm</td> <td>4.2 mm</td> <td>4.9 mm</td> </tr> </tbody> </table> <table border="1"> <thead> <tr> <th colspan="5">LE250 Models</th> </tr> <tr> <th colspan="2"></th> <th colspan="3">Distance</th> </tr> <tr> <th colspan="2"></th> <th>100 mm</th> <th>250 mm</th> <th>400 mm</th> </tr> </thead> <tbody> <tr> <td>X</td> <td></td> <td>3.2 mm</td> <td>2.1 mm</td> <td>1.2 mm</td> </tr> <tr> <td>Y</td> <td></td> <td>2.2 mm</td> <td>1.5 mm</td> <td>0.9 mm</td> </tr> </tbody> </table> </div>	LE550 Models							Distance					100 mm	550 mm	1000 mm	X		8.4 mm	10.5 mm	12.1 mm	Y		3.5 mm	4.2 mm	4.9 mm	LE250 Models							Distance					100 mm	250 mm	400 mm	X		3.2 mm	2.1 mm	1.2 mm	Y		2.2 mm	1.5 mm	0.9 mm
LE550 Models																																																			
		Distance																																																	
		100 mm	550 mm	1000 mm																																															
X		8.4 mm	10.5 mm	12.1 mm																																															
Y		3.5 mm	4.2 mm	4.9 mm																																															
LE250 Models																																																			
		Distance																																																	
		100 mm	250 mm	400 mm																																															
X		3.2 mm	2.1 mm	1.2 mm																																															
Y		2.2 mm	1.5 mm	0.9 mm																																															
Temperature Effect	LE250: ± 0.03 to ± 0.15 mm/ $^{\circ}$ C LE550: ± 0.25 to ± 0.5 mm/ $^{\circ}$ C																																																		
Analog Linearity	LE250: ± 0.375 to ± 0.9 mm LE550: ± 2 to ± 4.5 mm																																																		
Analog Resolution	LE550: Less than 0.5 mm (100 – 600 mm) Less than 1 mm (600 – 1000 mm) LE250: Less than 0.02 mm (100 – 250 mm) Less than 0.2 mm (250 – 400 mm)																																																		
Construction	Housing: die-cast zinc Lens: polycarbonate																																																		
Vibration/Mechanical Shock	IEC 60947-5-2																																																		
Operating Conditions	Temperature: -20 to +55 $^{\circ}$ C Humidity: 90% at +55 $^{\circ}$ C																																																		
Environmental Rating	IP67, NEMA 6																																																		
Certifications																																																			

LH Series

High-Precision Laser Measurement



- Highly precise laser technology of a 1024 pixel CMOS linear imager provides reliable and accurate measurement on most materials, including machined metal, wood, ceramic, paper and painted targets.
- Automatic laser power and measurement rate control for reliable measurement under changing or challenging conditions such as moving processes, hot parts, machined parts and a variety of colors and textures
- Robust, self-contained laser displacement sensor

Class 2 Laser LH



Sensing Mode	Measurement				Connection	Output	Spot Size at Reference Distance	Models
	Span	Start of Range	End of Range	Reference Distance				
 DIFFUSE LASER	10 mm	25 mm	35 mm	30 mm	8-pin Euro Pigtail QD	Analog 4-20 mA & RS-485	50 micron	LH30IX485QP
 DIFFUSE LASER	40 mm	60 mm	100 mm	80 mm	8-pin Euro Pigtail QD	Analog 4-20 mA & RS-485	125 micron	LH80IX485QP
 DIFFUSE LASER	100 mm	100 mm	200 mm	150 mm	8-pin Euro Pigtail QD	Analog 4-20 mA & RS-485	225 micron	LH150IX485QP

 Connection options: A model with a QD requires a mating cordset.



M12/Euro-Style with Shield
Straight connector models listed

8-Pin

- MQLH-806-F**
2 m (6.5')
- MQLH-815-F**
5 m (15')
- MQLH-830-F**
9 m (30')

Additional cordset information is available
See page 758



Double Ended M12/Euro-Style with Shield
Straight connector models only

8-Pin

Straight Male to Straight Female	—	Straight Male to Straight Male
MQLH-806-MF 2.0 m (6')	—	MQLH-801-MM 0.3 m (1')
MQLH-815-MF 5 m (15')	—	—
MQLH-830-MF 9 m (30')	—	—



Euro QD—Splitter with Shield

8-Pin

- CSB-M1280M1280-LH**
Branches 2 x 0 m
- CSB-M1281M1282-LH**
Branches 2 x 0.6 m (2')
- Trunk 0.3 m (1')
- CSB3-M1281M1282-LH**
Branches 3 x 0.6 m (2')
- Trunk 0.3 m (1')



SMBLH1 **SMBLH30** **SMBLH80** **SMBLH150**

Additional bracket information is available
See page 724

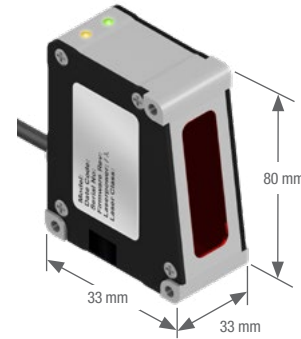

LH Specifications

Sensing Beam	670 nm (1mW) visible red IEC and CDRH Class 2 laser		
Supply Voltage and Current	18 to 30 V dc (10% max. ripple); 250 mA max. @ 24 V dc (exclusive of load)		
Supply Protection Circuitry	Protected against reverse polarity and transient over voltages		
Delay at Power-up	1.25 seconds		
Temperature Effect	0.01% of measurement range/ °C		
Linearity	0.1% of measurement range		
Resolution	LH30: 1 µm	LH80: 4 µm	LH150: 10 µm Resolution obtained with an average of 64 readings on a white ceramic target
Ambient Light	≤ 3000 Lux		
Measurement Frequency	Dynamically adjusted from 300 to 4000 Hz depending on target conditions, or locked via LH Series configurator software		
Indicators	Green: Power ON; Flashing = target at reference distance Orange: Target inside measurement range		
Construction	Housing: Aluminum	Cover: Aluminum	Lens: Glass Cable: PVC and nickel-plated brass
Environmental Rating	IP67		
Output Configuration	Analog current output: 4 to 20 mA (current sourcing) Analog output rating: 1 kΩ max. @ 24 V dc, max. load resistance = [(Vcc-4.5)/0.02]Ω		
Operating Conditions	Operating Temperature: -10 to +45 °C Storage Temperature: -10 to +80 °C Maximum relative humidity: 85% at +45 °C, non-condensing		
Vibration and Mechanical Shock	Vibration: 60 Hz, 30 minutes, 3 axes Shock: 30G for 11 milliseconds, half sine wave, 3 axes		
Application Notes	Allow 30-minute warm-up for specified performance		
Factory Default Settings	Mode: Displacement Mode Sensor Address: Unset (address 0) Baud Rate: 115200 Analog Output: 4-20 mA, positive slope, full range		
Certifications	CE		

LG Series

High-Precision Short-Range Laser Measurement



- The LG5 uses an ultra-narrow beam for applications requiring precise measurement of distance, height or thickness as well as gauging applications
- Replaces two-piece laser gauging sensors with completely self-contained, compact housing
- Houses discrete (switched) and analog outputs in the same unit, each independently programmable

Diffuse LG5

Visible Red Laser

Sensing Mode	Laser Class	Sensing Distance	Beam Size	Connection	Analog Output	Models NPN	Models PNP
 DIFFUSE LASER	Class 2	45-60 mm	At 53 mm: 0.4 mm x 0.6 mm Focus: 70 mm	2 m	0-10 V dc	LG5A65NU	LG5A65PU
				8-pin Euro Pigtail QD		LG5A65NUQ	LG5A65PUQ
 DIFFUSE LASER	Class 2	45-60 mm	At 53 mm: 0.1 mm Focus: 53 mm	2 m	4-20 mA	LG5A65NI	LG5A65PI
				8-pin Euro Pigtail QD		LG5A65NIQ	LG5A65PIQ
 DIFFUSE LASER	Class 2	45-60 mm	At 53 mm: 0.1 mm Focus: 53 mm	2 m	0-10 V dc	LG5B65NU	LG5B65PU
				8-pin Euro Pigtail QD		LG5B65NUQ	LG5B65PUQ
 DIFFUSE LASER	Class 2	45-60 mm	At 53 mm: 0.1 mm Focus: 53 mm	2 m	4-20 mA	LG5B65NI	LG5B65PI
				8-pin Euro Pigtail QD		LG5B65NIQ	LG5B65PIQ

Diffuse LG10

Visible Red Laser

Sensing Mode	Laser Class	Sensing Distance	Beam Size	Connection	Analog Output	Models NPN	Models PNP
 DIFFUSE LASER	Class 2	75-125 mm	At 125 mm: 0.6 mm x 0.8 mm Focus: 180 mm	2 m	0-10 V dc	LG10A65NU	LG10A65PU
				8-pin Euro Pigtail QD		LG10A65NUQ	LG10A65PUQ
 DIFFUSE LASER	Class 2	75-125 mm	At 125 mm: 0.6 mm x 0.8 mm Focus: 180 mm	2 m	4-20 mA	LG10A65NI	LG10A65PI
				8-pin Euro Pigtail QD		LG10A65NIQ	LG10A65PIQ

Connection options: A model with a QD requires a mating cordset.

For 9 m cable, add suffix W/30 to the 2 m model number (example, LG10A65PU W/30).

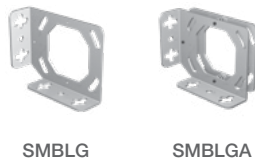

Additional cordset information is available See page 758

Additional bracket information is available See page 724

LG5 and LG10 Specifications

Sensing Beam	650 nm visible Red IEC and CDRH Class 2 laser; 0.20 mW max. radiant output power	
Supply Voltage and Current	12 to 30 V dc (10% max. ripple); 50 mA max. @ 24 V dc (exclusive of load)	
Supply Protection Circuitry	Protected against reverse polarity and transient overvoltages	
Delay at Power-up	1.25 second	
Output Rating	Discrete (switched) and Alarm outputs: 100 mA max. OFF-state leakage current: less than 5 µA Output saturation voltage PNP outputs: less than 1.2 V at 10 mA and less than 1.6 V at 100 mA NPN outputs: less than 200 mV at 10 mA and less than 600 mV at 100 mA Analog Current output: 1 kΩ max. @ 24 V dc, max. load resistance = [(Vcc - 4.5)/0.02]Ω Analog Voltage output: 2.5 kΩ min. load impedance	
Output Configuration	Discrete (switched) & alarm outputs: Solid-state switch; choose NPN (current sinking) or PNP (current sourcing) models Analog output: 4 to 20 mA (current sourcing) or 0 to 10 V dc (voltage sourcing), depending on model	
Output Protection	Discrete and alarm outputs are protected against continuous overload and short circuit	
Output Response Time	Discrete Outputs (ON/OFF) Fast: 2.0 milliseconds Medium: 10 milliseconds Slow: 100 milliseconds Analog Output (-3dB) Fast: 450 Hz (1 millisecond average/1 millisecond update rate) Medium: 45 Hz (10 millisecond average/2 millisecond update rate) Slow: 4.5 Hz (100 millisecond average/5 millisecond update rate)	
Analog Resolution and Repeatability of Discrete Trip Point*	LG5: Fast: Less than 40 µm @ 50 mm Medium: Less than 12 µm @ 50 mm Slow: Less than 3 µm @ 50 mm	LG10: Fast: Less than 150 µm @ 100 mm Medium: Less than 50 µm @ 100 mm Slow: Less than 10 µm @ 100 mm
Analog Linearity*	LG5: +/- 60 µm over 45 to 60 mm sensing window +/- 10 µm over 49 to 51 mm sensing window	LG10: +/- 200 µm over 75 to 125 mm sensing window +/- 20 µm over 95 to 100 mm sensing window
	*Resolution and linearity specified @ 24 V dc, 22 °C, using a white ceramic test surface (see Application Notes)	
Minimum Window Size (Analog or Discrete)	LG5: 1.5 mm	LG10: 5 mm
Discrete Output Hysteresis	LG5: Less than 0.2 mm	LG10: Less than 1.0 mm
Color Sensitivity (typical)	LG5: Less than 75 µm for white to dark gray ceramic target	LG10: Less than 100 µm for white to dark gray ceramic target
Temperature Effect	LG5: +/- 7 µm/ °C	LG10: +/- 25 µm/ °C
Adjustments	Response speed: Push button toggles between Slow, Medium, and Fast (see Output Response Time) Window limits (analog or discrete): TEACH-mode programming of near and far window limits. Limits may also be taught remotely using TEACH wire Analog output slope: The first limit taught is assigned to the minimum analog output (0 V dc or 4 mA)	
Indicators	Green Power ON LED: Indicates when power is ON, overloaded output and laser status Yellow Output LED: Indicates when discrete load output is conducting Red Signal LED: Indicates when target is within sensing range and the condition of the received light signal Tri-color Red/Green/Yellow TEACH LED: Indicates sensor is ready for programming each limit (indicates Red for analog output, Green for discrete, and Yellow for simultaneous analog and discrete) Yellow Fast/Slow LEDs: Combination of 2 lights ON or OFF indicates 1 of 3 response speeds	
Construction	Housing: Zinc alloy die-cast, plated and painted finish	Cover plate: Aluminum with painted finish Lens: Acrylic
Environmental Rating	IP67; NEMA 6	
Operating Conditions	Temperature: -10 to +50 °C	Relative humidity: 90% at 50 °C (non-condensing)
Vibration and Mechanical Shock	Vibration: 60 Hz, 30 minutes, 3 axes Shock: 30G for 11 milliseconds, half sine wave, 3 axes	
Certifications		

LT3 Series

Time-of-Flight Laser Distance-Gauging Sensors



- The LT3 uses advanced “time-of-flight” technology for precise, long-distance gauging.
- Reliably detects targets regardless of angles
- Visible red laser spot for easy alignment
- Offers push-button programming for other output response times or remote programming for added security and convenience

Diffuse LT3, Class 2 Laser

 Visible Red Laser

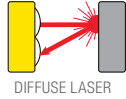
Sensing Mode	Range	Connection	Analog Output	Models NPN	Models PNP
 DIFFUSE LASER	0.3 to 5 m*	2 m	None	LT3BD (Dual NPN or PNP selectable)	
		8-pin Euro QD		LT3BDQ (Dual NPN or PNP selectable)	
	0.3 to 5 m*	2 m	0 to 10 V dc	LT3NU	
		8-pin Euro QD		LT3NUQ	
	0.3 to 5 m*	2 m	4 to 20 mA	LT3NI	
		8-pin Euro QD		LT3NIQ	

Retro LT3, Class 1 Laser

 Visible Red Laser

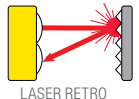
Sensing Mode	Range	Connection	Analog Output	Models NPN	Models PNP
 LASER RETRO	0.5 to 50 m†	2 m	None	LT3BDLV (Dual NPN or PNP selectable)	
		8-pin Euro QD		LT3BDLVQ (Dual NPN or PNP selectable)	
	0.5 to 50 m†	2 m	0 to 10 V dc	LT3NULV	
		8-pin Euro QD		LT3NULVQ	
	0.5 to 50 m†	2 m	4 to 20 mA	LT3NULVQ	
		8-pin Euro QD		LT3NULVQ	

 Connection options: A model with a QD requires a mating cordset.

For 9 m cable, add suffix W/30 to the 2 m model number (example, LT3BD W/30).

* Based on a 90% reflectivity white card

† Retroreflective range is specified using a BRT-TVHG-8X10P high-grade target.

Actual sensing range may differ, depending on the efficiency and reflective area of the retroreflector used. See Accessories for more information.



Euro QD (w/ Shield)
Straight connector models only

8-Pin
MQDC-806
 2 m (6')
MQDC-815
 5 m (15')
MQDC-830
 9 m (30')



SMBLT31



SMBLT32



SMBLT3IP



Additional cordset information is available
See page 758

Additional bracket information is available
See page 724

Reflectors



Additional information is available
See page 790

L-GAGE® LT3 Specifications

Sensing Beam	Typical beam diameter: 6 mm @ 3 m Typical laser lifetime: 75,000 hours Diffuse: 658 nm visible red IEC and CDRH Class 2 laser; 0.5 mW max. radiant output power Retroreflective: 658 nm visible red IEC and CDRH Class 1 laser; 0.15 mW max. radiant output power	
Sensing Range	Diffuse: 90% white card: 0.3 to 5 m 18% gray card: 0.3 to 3 m 6% black card: 0.3 to 2 m	Retroreflective: 0.5 to 50 m (using supplied target)
Supply Voltage and Current	12 to 24 V dc (10% max. ripple); 108 mA max. @ 24 V dc or [2600/V dc] mA	
Supply Protection Circuitry	Protected against reverse polarity and transient voltages	
Delay at Power-up	1 second; outputs do not conduct during this time	
Output Rating	Discrete (switched) output: 100 mA max. OFF-state leakage current: less than 5 µA Output saturation NPN: less than 200 mV @ 10 mA; less than 600 mV @ 100 mA Output saturation PNP: less than 1.2 V at 10 mA; less than 1.6 V at 100 mA Analog voltage output: 2.5 kΩ min. load impedance (voltage sourcing) Analog current output: 1 kΩ max. @ 24V; max. load resistance = [Vcc-4.5/0.02 Ω] (current sourcing)	
Output Protection	Protected against short circuit conditions	
Output Response Time	Discrete output Fast: 1 millisecond ON/OFF Medium: 10 milliseconds ON/OFF Slow: 100 milliseconds ON/OFF Diffuse Analog Voltage output (-3 dB) Retroreflective Analog Voltage output (-3 dB) Fast: 450 Hz (1 ms average/1 ms update rate) Fast: 114 Hz (6 ms average/ 1 ms update rate) Medium: 45 Hz (10 ms average/2 ms update rate) Medium: 10 Hz (48 ms average/ 1 ms update rate) Slow: 4.5 Hz (100 ms average/4 ms update rate) Slow: 2.5 Hz (192 ms average/ 1 ms update rate)	
Color Sensitivity (typical)	Diffuse: 90% white to 18% gray: less than 10 mm; 90% white to 6% black: less than 20 mm.	
Analog Linearity	Retroreflective: ± 60 mm from 0.5 to 50 m (0.12% of full scale) (Specified @ 24 V dc, 22° C using supplied BRT-TVHG-8X10P retroreflector)	Diffuse: ± 30 mm from 0.3 to 1.5 m; ± 20 mm from 1.5 to 5 m (Specified @ 24 V dc, 22° C using a 90% reflectance white card)
Discrete Output Hysteresis	Diffuse Fast: 10 mm Medium: 5 mm Slow: 3 mm	Retroreflective Fast: 20 mm Medium: 10 mm Slow: 6 mm
Temperature Effect	Diffuse: less than 2 mm/° C	Retroreflective: less than 3 mm/° C
Minimum Window Size	Diffuse: 20 mm	Retroreflective: 40 mm
Remote TEACH Input	18 kΩ min. (65 kΩ at 5 V dc)	
Remote TEACH	To teach: Connect yellow wire to +5 to 24 V dc To disable: Connect yellow wire to 0 to +2 V dc (or open connection)	
Construction	Housing: ABS/polycarbonate blend	Window: Acrylic Quick-disconnect: ABS/polycarbonate blend
Environmental Rating	IP67; NEMA 6	
Operating Conditions	Temperature: 0 to +50 °C	Relative humidity: 90% at 50 °C (non-condensing)
Certifications		

LT7 Series

Time-of-Flight Laser Distance-Gauging Sensors



- Visible red laser spot during programming mode for easy alignment
- Features TEACH-mode programming using integrated push-buttons or a serial interface
- Onboard LCD display for easy troubleshooting
- Long-range retroreflective models up to 250 m and diffuse models up to 10 m

Diffuse L-GAGE® LT7

Infrared Laser

Sensing Mode	Laser Class	Sensing Distance*	Connection	Discrete Output	Analog Output	Serial	Models
DIFFUSE LASER	Class 1 Infrared Sensing Laser (Class 2 Visible Red Alignment Laser)	0.5 to 10 m	12-pin M16 QD	2 PNP	4-20 mA	RS-422 or SSI	LT7PIDQ

Retro L-GAGE® LT7

Infrared Laser

Sensing Mode	Laser Class	Sensing Distance*	Connection	Discrete Output	Analog Output	Serial	Models
RETRO LASER	Class 1 Infrared Sensing Laser (Class 2 Visible Red Alignment Laser)	0.5 to 250 m	12-pin M16 QD	2 PNP	—	RS-422 or SSI	LT7PLVQ

Connection options: A model with a QD requires a mating cordset.
 *Diffuse-mode range specified using a 90% reflectance white card.
 Retroreflective range is specified using a BRT-250, BRT-540 or BRT-700 retroreflective target (see page page 790).



Euro QD (w/ Shield)
Straight connector models listed; for right-angle, replace **ST** with **RA** at the end of the model number (example, **MQDC-1210RA**)

12-Pin
MQDC-1210ST 3 m
MQDC-1213ST 10 m

Additional cordset information is available
See page 758



SMBLT7

Additional bracket information is available
See page 724

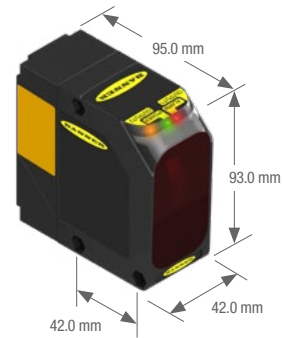

Reflectors



Additional information is available
See page 790









L-GAGE® LT7 Specifications

Sensing Range	LT7PLVQ: 0.5 to 250 m (using specified reflector) LT7PIDQ: 6% Black card: 0.5 to 3 m 18% Gray card: 0.5 to 7 m 90% White card: 0.5 to 10 m																									
Supply Voltage and Current	18 to 30 V dc (10% max. ripple)																									
Power Consumption	Less than 4.5 W @ 25° C																									
Measuring Laser	Infrared, 900 nm, Class 1																									
Laser Control	Measurement laser is ON when sensor is ON. Pilot (visible) laser enabled during Programming mode; alternates with measurement laser.																									
Spot Size	<table border="1"> <thead> <tr> <th></th> <th>Distance</th> <th>Spot Size</th> <th>Distance</th> <th>Spot Size</th> </tr> </thead> <tbody> <tr> <td>LT7PLVQ:</td> <td>10 m</td> <td>ø 20 mm</td> <td>LT7PIDQ: 4 m</td> <td>3 x 10 mm</td> </tr> <tr> <td></td> <td>50 m</td> <td>ø 100 mm</td> <td>6 m</td> <td>4 x 12 mm</td> </tr> <tr> <td></td> <td>100 m</td> <td>ø 200 mm</td> <td>10 m</td> <td>10 x 20 mm</td> </tr> <tr> <td></td> <td>250 m</td> <td>ø 500 mm</td> <td></td> <td></td> </tr> </tbody> </table>		Distance	Spot Size	Distance	Spot Size	LT7PLVQ:	10 m	ø 20 mm	LT7PIDQ: 4 m	3 x 10 mm		50 m	ø 100 mm	6 m	4 x 12 mm		100 m	ø 200 mm	10 m	10 x 20 mm		250 m	ø 500 mm		
	Distance	Spot Size	Distance	Spot Size																						
LT7PLVQ:	10 m	ø 20 mm	LT7PIDQ: 4 m	3 x 10 mm																						
	50 m	ø 100 mm	6 m	4 x 12 mm																						
	100 m	ø 200 mm	10 m	10 x 20 mm																						
	250 m	ø 500 mm																								
Pilot Laser (Alignment)	Visible red, 650 nm, Class 2																									
Discrete & Analog Output Protection	Protected against continuous overload and short circuit																									
Discrete Outputs	(2) 100 mA, PNP																									
Discrete Switch Points	Adjustable in 1 mm steps																									
Discrete Output Hysteresis	Adjustable, 10 mm min.																									
Alarm Outputs	50 mA, PNP (NO)																									
Analog Output	LT7PLVQ: None LT7PIDQ: 4-20 mA																									
Output Response Time	12 milliseconds																									
Linearity	±10 mm																									
Resolution/Repeatability	LT7PLVQ: ±2 mm LT7PIDQ: ±4 mm																									
Temperature Effect	Less than ± 5 mm over the total sensing range																									
Minimum Analog Window Size	LT7PLVQ: Not Applicable LT7PIDQ: 300 mm																									
Adjustments	Push-button directed password enable/disable, measurement unit select, offset value select, output limits set, output mode select, analog output slope select (diffuse models only) and output limit manual adjust. See datasheet for information.																									
Serial Measurement Speed	SSI: 1.4 milliseconds (SSI cycle 80 microseconds) RS-422: 2.9 milliseconds @ 57.6 kBaud																									
Construction	ABS shock-resistant housing; PMMA window; polycarbonate displays																									
Weight	Approximately 230 g																									
Environmental Rating	IEC IP67																									
Operating Conditions	Temperature: -10 to +50 °C in continuous operation																									
Storage Temperature	-30 to +75 °C																									
Vibration/Shock	EN 60947-5-2																									
Certifications	CE																									



Ultrasonic

Ultrasonic sensors use sound waves rather than light, making them ideal for stable detection of uneven surfaces, liquids, clear objects, and objects in dirty environments. These sensors work well for applications that require precise measurements between stationary and moving objects.

Series	Description	Max Sensing Range	Dimensions H x W x D (mm)	Protection Rating	Housing Material	Power Supply
	QT50U The QT50U features a completely sealed, shock-resistant housing that is ideal for monitoring levels of liquids and solids. page 218	8 m	84.2 x 74.1 x 67.4	IP67; NEMA 6P	ABS/ Polycarbonate	10 to 30 V dc, 85 to 264 V ac
	S18U The S18U is ideal for material handling and packaged goods applications, such as bottling or liquid level detection and as a control for small containers. page 222	300 mm	80.8 x ø 18	IP67; NEMA 6P	Thermoplastic polyester	10 to 30 V dc
	T30U/T30UX The T30UX features T-style, right-angle sensor package with a 30 mm threaded barrel and a wide variety of mounting options. page 226	3 m	51.5 x 40 x 45	IP67; NEMA 6	PTB polyester	10 to 30 V dc, 12 to 24 V dc, 15 to 24 V dc
	M25U The M25U Ultrasonic Sensor features a smooth 316 series stainless steel construction to withstand the toughest sanitary challenges. page 226	500 mm	103 x ø 25	IP67; NEMA 6, IP69K	316 Stainless Steel	10 to 30 V dc
	T18U The T18U offers versatile mounting, and a response time of 1 millisecond. page 230	600 mm	51.5 x 40 x 30	IP67; NEMA 6P	PTB polyester	12 to 30 V dc
	Q45U The Q45U accepts programming storage cards for fast and easy sensing parameter changes. page 232	3 m	87.6 x 44.5 x 60.5	IP67; NEMA 6P	PTB polyester	12 to 24 V dc, 15 to 24 V dc
	Q45UR The Q45UR has sensing head choices of 18 mm diameter threaded barrel housing in plastic or stainless steel, or ultra-compact plastic Flat-Pak. page 234	250 mm	87.6 x 44.5 x 60.5 (Remote sensors vary by model)	IP67; NEMA 6P	Thermoplastic polyester	12 to 24 V dc, 15 to 24 V dc
	QS18U The QS18U senses clear and transparent materials, as well as color variations, including clear web material, clear or shiny bottles, highly reflective surfaces and liquid or dry bulk materials inside cramped locations. page 236	500 mm	41.5 x 15 x 33.5	IP67 or IP68; NEMA 6P	ABS	12 to 30 V dc
	K50U Designed for plug-and-play use with the Q45U wireless node, creating a cost-effective and easy-to-use solution for monitoring mobile or remote tanks and totes page 238	3 m	59.5 x ø 50	IP67 NEMA 6P	PTB polyester	3.6 to 5.5 V dc or 10 to 30 V dc

QT50U Series

Long-Range Ultrasonic Sensors



- Features a small ultrasonic dead zone of 200 mm
- Available in a chemically resistant model with a Teflon® flange
- Detects targets at long ranges within confined areas, such as a storage tank, without interference from the tank walls
- Push-button and remote TEACH-mode programming with an external switch, computer or controller for added security and convenience

QT50U, 10-30 V DC

Range	Connection	Output	Models*
200 mm to 8 m	2 m	Selectable 0 to 10 V dc or 4 to 20 mA	QT50ULB
	5-pin Mini QD		QT50ULBQ
	5-pin Euro QD		QT50ULBQ6
200 mm to 8 m	2 m	Selectable Dual NPN or PNP	QT50UDB
	5-pin Mini QD		QT50UDBQ
	5-pin Euro QD		QT50UDBQ6

QT50U Universal Voltage, 85-264 V AC/48-250 V DC

Range	Connection	Output Operation Mode	Output	Models*
200 mm to 8 m	2 m	Window-limit (complementary outputs)	SPDT e/m relay	QT50UVR3W
	5-pin Micro QD			QT50UVR3WQ1
	5-pin Mini QD			QT50UVR3WQ
200 mm to 8 m	2 m	Pump/level control (pump-in and pump-out logic)	SPDT e/m relay	QT50UVR3F
	5-pin Micro QD			QT50UVR3FQ1
	5-pin Mini QD			QT50UVR3FQ

For more specifications see page 220-221.

 Connection options: A model with a QD requires a mating cordset.

For 9 m cable, add suffix W/30 to the 2 m model number (example, QT50ULB W/30).

* For sensors with Teflon®-protected face and transducer, add suffix -CRFV to the model number (example, QT50ULB-CRFV).

Teflon® is a registered trademark of Dupont™.



5-Pin

Euro-Style with Shield

Straight connector models listed; for right-angle, add **RA** to the end of the model number (example, **MQDEC2-506RA**)

- MQDEC2-506**
2 m (6.5')
- MQDEC2-55**
5 m (15')
- MQDEC2-530**
9 m (30')



5-Pin

Micro-Style

Straight connector models listed; for right-angle, add **RA** to the end of the model number (example, **MQVR3S-506RA**)

- MQVR3S-506**
2 m (6.5')
- MQVR3S-515**
5 m (15')
- MQVR3S-50**
9 m (30')



5-Pin

Mini-Style

Straight connector models only

- MBCC2-506**
2 m (6.5')
- MBCC2-512**
4 m (15')
- MBCC2-530**
9 m (30')

Additional cordset information is available
See page 758



SMB30A



SMB30MM

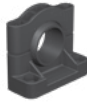

SMB30SC

Additional bracket information is available
See page 725



DC and Universal Voltage Models



Teflon®-protected Models
(Suffix -CRFV)

QT50U Universal Voltage Specifications

Supply Voltage	85 to 264 V ac, 50/60 Hz/48 to 250 V dc (1.5 watts max., exclusive of load)
Ultrasonic Frequency	75 kHz burst, rep. rate 96 milliseconds
Supply Protection Circuitry	Protected against transient over voltages. DC hookup is without regard to polarity.
Output Protection	Protected against short circuit conditions
Delay at Power-up	1.5 seconds
Output Configuration	SPDT (Single-Pole, Double-Throw) electromechanical relay output One normally open (NO) and one normally closed (NC)
Output Ratings	<p>Max. switching power (resistive load): 2000 VA, 240 W (1000 VA, 120 W for sensors with Micro QD)</p> <p>Max. switching voltage (resistive load): 250 V ac, 125 V dc</p> <p>Max. switching current (resistive load): 8A @ 250 V ac, 8A @ 30 V dc derated to 200 mA @ 125 V dc (4A max. for sensors with Micro QD)</p> <p>Min. voltage and current: 5 V dc, 10 mA</p> <p>Mechanical life of relay: 50,000,000 operations</p> <p>Electrical life of relay at full resistive load: 100,000 operations</p> <p>NOTE: Transient suppression is recommended when switching inductive loads</p>
Temperature Effect	Uncompensated: 0.2% of distance/ °C Compensated: 0.02% of distance/ °C
Repeatability	1.0 mm
Hysteresis	Window-limit sensor models: 5 mm Fill-level control sensor models: 0 mm
Output Response Time	Selectable 1600, 400 or 100 milliseconds
Minimum Window Size	20 mm
Adjustments	<p>Sensing limits: TEACH-Mode programming of near and far limits may be set using the TEACH push button</p> <p>Sensor configuration: Output response time and temperature compensation mode may be set using the Speed push button</p> <p>Factory default settings: 400 milliseconds output response time; temperature compensation enabled</p>
Indicators	<p>Green Power ON LED: Indicates power is ON</p> <p>Red Signal LED: Indicates target is within sensing range, and the condition of the received signal</p> <p>Output indicator (bicolor Yellow/Red): Indicates output status or TEACH mode</p> <p>Response indicator (bicolor Yellow/Red): Indicates output response time selection</p>
Construction	<p>Transducer: Ceramic/Epoxy composite</p> <p>Housing: ABS</p> <p>Membrane Switch: Polyester</p>
Environmental Rating	Leakproof design is rated IEC IP67; NEMA 6P
Operating Conditions	Temperature: -20 to +70 °C Relative humidity: 100%
Vibration and Mechanical Shock	All models meet Mil Std. 202F requirements. Method 201A (vibration: 10 to 60Hz max., double amplitude 0.06", maximum acceleration 10G). Also meets IEC 947-5-2 requirements: 30G 11 milliseconds duration, half sine wave.
Temperature Warmup Drift	Less than 1.0% of sensing distance upon power-up with Temperature Compensation enabled
Application Notes	Objects passing inside the specified minimum sensing distance (200 mm) may produce a false response
Certifications	

S18U Series

Barrel Ultrasonic Sensors



- Features minimal dead zone and can eliminate dead zone if used in retrosonic mode
- Compensates for temperature to provide greatest sensing accuracy
- Push-button and remote TEACH-mode programming with an external switch, computer or controller for added security and convenience



S18U

Range	Connections	Output	Housing Configuration	Models
30 to 300 mm	2 m	0 to 10 V dc	Straight	S18UUA
	5-pin Euro QD			S18UUAQ
30 to 300 mm	2 m	4 to 20 mA	Straight	S18UIA
	5-pin Euro QD			S18UIAQ
30 to 300 mm	2 m	Bipolar NPN/PNP	Straight	S18UBA
	5-pin Euro QD			S18UBAQ

S18U Right-Angle

Range	Connections	Output	Housing Configuration	Models
30 to 300 mm	2 m	0 to 10 V dc	Right-Angle	S18UJAR
	5-pin Euro QD			S18UJARQ
30 to 300 mm	2 m	4 to 20 mA	Right-Angle	S18UIAR
	5-pin Euro QD			S18UIARQ
30 to 300 mm	2 m	Bipolar NPN/PNP	Right-Angle	S18UBAR
	5-pin Euro QD			S18UBARQ

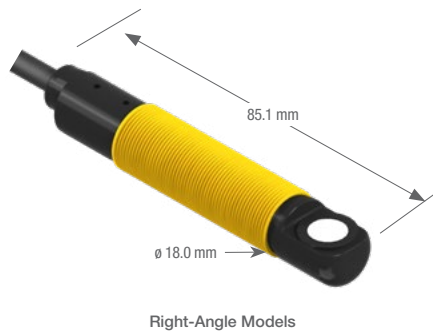

 Connection options: A model with a QD requires a mating cable.

For 9 m cable, add suffix W/30 to the 2 m model number (example, S18UUA W/30).



5-Pin

Euro-Style with Shield
Straight connector models listed; for right-angle, add **RA** to the end of the model number (example, MQDEC2-506RA)

MQDEC2-506
2 m (6.5')
MQDEC2-515
5 m (15')
MQDEC2-530
9 m (30')

Additional cordset information is available
See page 758



SMB18A



SMB18FM

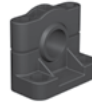

SMB18SF

Additional bracket information is available
See page 723

Ultrasonic Wave Guides



Inside Diameter	Model
5.0 mm	UWG18-5.0
6.4 mm	UWG18-6.4

Additional wave guide information is available
See page 959

S18U Specifications

Supply Voltage and Current	10 to 30 V dc (10% max. ripple); 65 mA max. (exclusive of load), 40 mA typical @ 25 V input	
Ultrasonic Frequency	300 kHz, rep. rate 2.5 milliseconds	
Supply Protection Circuitry	Protected against reverse polarity and transient voltages	
Output Protection	Protected against short circuit conditions	
Output Ratings	<p>Analog Voltage Output: 2.5 kΩ min. load resistance Minimum supply for a full 10 V output is 12 V dc (for supply voltages between 10 and 12, V out max is at least V supply -2) Analog Current Output: 1 kΩ max @ 24 V input Max load resistance = (Vcc-4)/0.02 Ω</p> <p>Discrete: 100 mA max. OFF-state leakage current: less than 5 μA NPN saturation: less than 200 mV @ 10 mA and less than 600 mV @ 100 mA PNP saturation: less than 1.2 V @ 10 mA and less than 1.6 V @ 100 mA</p>	
Output Configuration	<p>Analog: 0 to 10 V dc or 4 to 20 mA, depending on model Discrete: Bipolar: One NPN (current sinking) and one PNP (current sourcing) output in each model. Solid-state switch conducts when target is sensed within sensing window.</p>	
Output Response Time	Analog: 30 milliseconds: Black wire at 0 to 2 V dc (or open)	2.5 milliseconds: Black wire at 5 to 30 V dc
Delay at Power-up	300 milliseconds	
Linearity	Analog output models: 2.5 milliseconds response: ± 1 mm	30 milliseconds response: ± 0.5 mm
Resolution	Analog output models: 2.5 milliseconds response: 1 mm	30 milliseconds response: 0.5 mm
Repeatability	Discrete models: 0.5 mm	
Temperature Effect	0.02% of distance/ °C	
Temperature Warmup Drift	Less than 1.7% of sensing distance upon power-up	
Minimum Window Size	5 mm	
Switching Hysteresis	Discrete output models: 0.7 mm	
Adjustments	Sensing window limits: TEACH-Mode programming of near and far window limits may be set using the push button or remotely using TEACH input	
Indicators	<p>Power/Signal Strength (Red/Green): Green: Target is within sensing range Red: Target is outside sensing range OFF: Sensing power is OFF</p>	<p>Teach/Output Indicator (Yellow/Red): Yellow: Target is within taught limits OFF: Target is outside taught window limits Red: Sensor is in TEACH mode</p>
Remote TEACH Input	Impedance: 12 kΩ	
Construction	Threaded Barrel: Thermoplastic polyester Push Button: Santoprene	Push Button Housing: ABS/PC Lightpipes: Acrylic
Environmental Rating	Leakproof design is rated IEC IP67; NEMA 6P	
Operating Conditions	Temperature: -20 to +60 °C	Relative humidity: 100%
Vibration and Mechanical Shock	All models meet Mil. Std. 202F requirements. method 201A (vibration: 10 to 60 Hz max., double amplitude 0.06", maximum acceleration 10G). Also meets IEC 947-5-2 requirements: 30G 11 milliseconds duration, half sine wave	
Application Notes	Objects passing inside the specified near limit may produce a false response	
Certifications		

T30UX Series

Right-Angle, Long-Range Ultrasonic Sensors



- Built-in temperature compensation for high-accuracy across a wide range of ambient temperatures
- Resists harsh environments with rugged IP67 (NEMA 6) housing and fully encapsulated electronics
- Push-button and remote TEACH-mode programming with an external switch, computer or controller for added security and convenience

T30UX

Range	Frequency	Connection	Response Time	Output	Models*
100 mm to 1 m	224 kHz	2 m 4-Pin Euro QD	45 ms	Discrete: NPN, PNP, NO, NC, Selectable	T30UXDA T30UXDAQ8
200 mm to 2 m	174 kHz	2 m 4-Pin Euro QD	92 ms	Discrete: NPN, PNP, NO, NC, Selectable	T30UXDB T30UXDBQ8
300 mm to 3 m	114 kHz	2 m 4-Pin Euro QD	135 ms	Discrete: NPN, PNP, NO, NC, Selectable	T30UXDC T30UXDCQ8
100 mm to 1 m	224 kHz	2 m 4-Pin Euro QD	Selectable 45 or 105 ms	Analog: 0 to 10 V dc	T30UXUA T30UXUAQ8
100 mm to 1 m	224 kHz	2 m 4-Pin Euro QD	Selectable 45 or 105 ms	Analog: 4 to 20 mA	T30UXIA T30UXIAQ8
200 mm to 2 m	174 kHz	2 m 4-Pin Euro QD	Selectable 92 or 222 ms	Analog: 0 to 10 V dc	T30UXUB T30UXUBQ8
200 mm to 2 m	174 kHz	2 m 4-Pin Euro QD	Selectable 92 or 222 ms	Analog: 4 to 20 mA	T30UXIB T30UXIBQ8
300 mm to 3 m	114 kHz	2 m 4-Pin Euro QD	Selectable 135 or 318 ms	Analog: 0 to 10 V dc	T30UXUC T30UXUCQ8
300 mm to 3 m	114 kHz	2 m 4-Pin Euro QD	Selectable 135 or 318 ms	Analog: 4 to 20 mA	T30UXIC T30UXICQ8

 Connection options: A model with a QD requires a mating cordset.

For 9 m cable, add suffix W/30 to the 2 m model number (example, T30UXDA W/30).

QD models: For a 4-pin 150 mm Euro-style PUR pigtail QD, add suffix QPMA to the 2 m model number (example, T30UXDAQPMA).

* Contact factory to request chemically resistant flange or fill-level control models.



4-Pin

Euro-Style with Shield
Straight connector models listed; for right-angle, add **RA** to the end of the model number (example, MQDEC2-406RA)

- MQDEC2-406
2 m (6.5')
- MQDEC2-415
5 m (15')
- MQDEC2-430
9 m (30')

Additional cordset information is available
See page 758



SMB30A



SMB30FA..

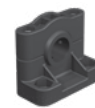

SMB1815SF

Additional bracket information is available
See page 723



T30UX (Long-range) Models

T30UX Specifications

Supply Voltage and Current	10 to 30 V dc (10% max. ripple) at 40 mA, exclusive of load		
Supply Protection Circuitry	Protected against reverse polarity and transient voltages		
Output Configuration	Discrete (switched) output models: SPST solid-state switch. Configurable as NPN (sinking) or PNP (sourcing) via Mode push button. Normally Open (NO) or Normally Closed (NC) operation is also selectable via Mode push button. The default setting is PNP/NO. Analog output models: 0 to 10 V dc or 4 to 20 mA, depending on model		
Output Ratings	Discrete output models: 100 mA max. OFF-state leakage current: NPN: < 200 µA @ 30 V dc (see NOTE 1) PNP: < 10 µA @ 30 V dc ON-state saturation voltage: NPN: < 1.6 V @ 100 mA PNP: < 3 V @ 100 mA Analog output models: Analog Voltage Output: 2.5 kΩ min. load resistance Minimum supply for a full 10 V output is 12 V dc (for supply voltages between 10 and 12, V out max. is at least V supply -2) Analog Current Output: 1 kΩ max. @ 24 V input; max. load resistance = (Vcc-4)/0.02Ω For current output (4-20 mA) models, ideal results are achieved when the total load resistance R = [(Vin - 4)/0.020]Ω. Example, at Vin = 24 V dc, R ≈ 1 kΩ (1 watt)		
Output Protection Circuitry	Protected against short circuit conditions		
Output Response Time	"A" suffix models: 45 milliseconds	"B" suffix models: 92 milliseconds	"C" suffix models: 135 milliseconds
Delay at Power-up	500 milliseconds		
Temperature Effect	0.02% of distance/ °C		
Linearity (analog models)	0.25% of distance		
Repeatability/Resolution	"A" suffix models: 0.1% of distance (0.5 mm min.) "B" suffix models: 0.1% of distance (1.0 mm min.) "C" suffix models: 0.1% of distance (1.5 mm min.)		
Sensing Hysteresis (discrete models)	"A" suffix models: 2 mm	"B" suffix models: 3 mm	"C" suffix models: 4 mm
Minimum Window Size	10 mm		
Adjustments	Sensing window limits: TEACH-Mode configuration of near and far window limits may be set using the push button or remotely via TEACH input Discrete output models: Output Configuration: NPN, PNP, Normally Open (NO), Normally Closed (NC) select Advanced configuration options: Push button enabled/disabled, temperature compensation enabled/disabled Analog output models: Response speed selection: Fast or Slow Advanced configuration options: Analog output slope, push button enabled/disabled, temperature compensation enabled/disabled		
Indicators	Green Power LED ON: Power ON, RUN mode Red Signal LED: Target signal strength Amber Output LED: Output enabled; sensor receiving a signal within the window limits Amber Mode LED: Currently selected mode		
Loss of Signal Indication (analog models)	0 to 10 V dc models: Analog output goes to 0 V 4 to 20 mA models: Analog output goes to 3.6 mA		
Construction	Housing: PBT polyester Push buttons: Polyester Transducer: Epoxy /ceramic composite		
Environmental Rating	Leakproof design, rated IEC IP67 (NEMA 6)		
Operating Conditions	Temperature: -40 to +70 °C Relative humidity: 95% at 50 °C non-condensing		
Vibration and Mechanical Shock	All models meet Mil. Std. 202F requirements. Method 201A (Vibration: 10 to 60Hz max., double amplitude 0.06", maximum acceleration 10G). Also meets IEC 947-5-2 requirements: 30G, 11 milliseconds duration, half sine wave.		
Application Notes	The temperature warmup drift upon power-up is less than 1% of the sensing distance		
Certifications			

NOTE: NPN < 200 µA for load impedance > 3 kΩ; for load current of 100 mA, leakage < 1% of load current

T30U Series

Right-Angle, Long-Range Ultrasonic Sensors



- Dual-discrete models for ON/OFF switching or pump-level control
- Resists harsh environments with rugged IP67 (NEMA 6) housing and fully encapsulated electronics
- Chemically resistant models with a Teflon® coating
- Push-button and remote TEACH-mode programming with an external switch, computer or controller for added security and convenience

T30U, 12-24 V DC

Range	Frequency	Connection	Response Time	Discrete Output(s)	Analog Output	Models*
150 mm to 1 m	228 kHz	2 m	48 ms	NPN	4 to 20 mA	T30UINA
		5-pin Euro QD				T30UINAQ
		2 m		PNP		T30UIPA
		5-pin Euro QD				T30UIPAQ
300 mm to 2 m†	128 kHz	2 m	96 ms	NPN	4 to 20 mA	T30UINB
		5-pin Euro QD				T30UINBQ
		2 m		PNP		T30UIPB
		5-pin Euro QD				T30UIPBQ
150 mm to 1 m	228 kHz	2 m	48 ms	Dual NPN	None	T30UDNA
		5-pin Euro QD				T30UDNAQ
		2 m		Dual PNP		T30UDPA
		5-pin Euro QD				T30UDPAQ
300 mm to 2 m†	128 kHz	2 m	96 ms	Dual NPN	None	T30UDNB
		5-pin Euro QD				T30UDNBQ
		2 m		Dual PNP		T30UDPB
		5-pin Euro QD				T30UDPBQ
150 mm to 1 m	228 kHz	2 m	48 ms	Pump/Level Control	None	T30UHNA
		5-pin Euro QD				T30UHNAQ
300 mm to 2 m†	128 kHz	2 m	96 ms	Dual NPN	None	T30UHNB
		5-pin Euro QD				T30UHNBQ
150 mm to 1 m	228 kHz	2 m	48 ms	Pump/Level Control	None	T30UHPA
		5-pin Euro QD				T30UHPAQ
300 mm to 2 m†	128 kHz	2 m	96 ms	Dual PNP	None	T30UHPB
		5-pin Euro QD				T30UHPBQ

 Connection options: A model with a QD requires a mating cordset.

For 9 m cable, add suffix W/30 to the 2 m model number (example, T30UXDA W/30).

QD models: For a 4-pin 150 mm Euro-style PUR pigtail QD, add suffix QPMA the 2 m model number (example, T30UXDAQPMA).

* Contact factory to request chemically resistant flange or fill-level control models.

† Teflon®-encapsulated models have a range of 300 mm - 1.5 m

T30U, 15-24 V DC

Range	Frequency	Connection	Response Time	Analog Output	Models NPN*	Models PNP*
150 mm to 1 m	228 kHz	2 m 5-pin Euro QD	48 ms	0 to 10 V dc	T30UUNA T30UUNAQ	T30UUPA T30UUPAQ
300 mm to 2 m†	128 kHz	2 m 5-pin Euro QD	96 ms	0 to 10 V dc	T30UUNB T30UUNBQ	T30UUPB T30UUPBQ

 Connection options: A model with a QD requires a mating cordset

For 9 m cable, add suffix W/30 to the 2 m model number (example, T30UUNA W/30).

* For sensors with Teflon®-protected face and transducer (long-range models only), add suffix -CRFV to the model number (example, T30UUNB-CRFV).

† Teflon®-encapsulated models have a range of 300 mm - 1.5 m.

Teflon® is a registered trademark of Dupont™.

 **Euro-Style with Shield**
Straight connector models listed; for right-angle, add RA to the end of the model number (example, MQDEC2-506RA)

5-Pin
MQDEC2-506
2 m (6.5')
MQDEC2-515
5 m (15')
MQDEC2-530
9 m (30')

 **SMB30A**

 **SMB30FA..**

 **SMB1815SF**

Additional cordset information is available
See page 758

Additional bracket information is available
See page 723



T30U Specifications

Supply Voltage and Current	<p>Current sourcing analog output models: 12 to 24 V dc (10% max. ripple); 90 mA (exclusive of load)</p> <p>Voltage sourcing analog output models: 15 to 24 V dc (10% max. ripple); 90 mA (exclusive of load)</p> <p>Dual-discrete output models: 12 to 24 V dc (10% max. ripple); 90 mA (exclusive of load)</p>
Supply Protection Circuitry	Protected against reverse polarity and transient voltages
Ultrasonic Frequency	<p>Short Range ("A" suffix modes): 228 kHz</p> <p>Long Range ("B" suffix models): 128 kHz</p>
Output Protection	Protected against continuous overload and short-circuit; transient over-voltage; no false pulse on power-up
Output Configuration	<p>Discrete (switched) output: Solid-state switch conducts when target is sensed within sensing window; choose NPN (current sinking) or PNP (current sourcing) models</p> <p>Analog output: Choose 0 to 10 V dc sourcing or 4 to 20 mA sourcing output models; output slope may be selected using TEACH sequence</p>
Output Ratings	<p>Discrete (switched) output: 100 mA max., total-both outputs</p> <p>OFF-state leakage current: less than 10 µA</p> <p>ON-state saturation voltage: less than 1 V at 10 mA and less than 1.5 V at 100 mA</p> <p>Analog Output:</p> <p>Voltage sourcing: 0 to 10 V dc (at 1 kΩ min. resistance)</p> <p>Current sourcing: 4 to 20 mA, 1 Ω to Rmax $R_{max} = \frac{V_{supply} - 7V}{20 \text{ mA}}$</p>
Output Response Time	<p>Discrete output: "A" suffix models: 48 milliseconds "B" suffix models: 96 milliseconds</p> <p>Analog output: "A" suffix models: 48 milliseconds average, 16-millisecond update</p> <p>"B" suffix models: 96 milliseconds average, 32-millisecond update</p>
Sensing Performance (Specified using a 100 x 100 mm aluminum target at 25° C under fixed sensing conditions.)	<p>Analog sensing resolution or discrete output repeatability: ±0.25% of measured distance</p> <p>"A" suffix models: .5 mm min "B" suffix models: 1 mm min</p> <p>Analog linearity: ±0.5% of full-scale span</p> <p>Min. window size: 10 mm Hysteresis of discrete output: 2.5 mm Temperature effect: 0.2% of sensing distance per °C</p>
Indicators	<p>Four status LEDs: In RUN mode:</p> <p>Green ON Steady: Power ON, RUN mode</p> <p>Green Flashing: Discrete output is overloaded</p> <p>Red Flashing: Relative received signal strength</p> <p>Yellow analog ON Steady: Target is inside window limits</p> <p>Yellow discrete ON Steady: Output conducting</p> <p>In Program mode:</p> <p>Green OFF: PROGRAM mode</p> <p>Red Flashing: Relative received signal strength</p> <p>Yellow ON Steady: Ready for first window limit</p> <p>Yellow Flashing: Ready for second limit</p> <p>Yellow OFF: Not teaching this output</p>
Construction	Molded reinforced thermoplastic polyester housing
Environmental Rating	Leakproof design is rated IEC IP67; NEMA 6P
Operating Conditions	<p>Temperature: -20 to +70 °C Relative humidity: 100%</p>
Vibration and Mechanical Shock	All models meet Mil. Std. 202F requirements. Method 201A (Vibration: 10 to 60Hz max., double amplitude 0.06", maximum acceleration 10G). Also meets IEC 947-5-2 requirements: 30G, 11 milliseconds duration, half sine wave.
Certifications	

M25U Series

Stainless Steel Opposed Ultrasonic Sensors



- 316 stainless steel with no thread, gaps or seams to trap debris
- Constructed with FDA approved materials and rated to IP69K, IEC IP67 (NEMA 6) with fully encapsulated electronics
- Withstands high-temperature sprays of up to 80° C and 1500 psi occurring every few hours
- Features high-immunity to ambient electrical and sonic noise

M25U

Range*	Frequency	Connection	Output	Response Time	Models
Normal Speed: 500 mm High Speed: 250 mm	140 kHz	4-pin Euro QD	—	—	M25UEQ8 Emitter
		5-pin Euro QD	Bipolar NPN/PNP	Normal Speed: 4.0 ms High Speed: 3.0 ms	M25URBQ8 Receiver

 Connection options: A model with a QD requires a mating cordset.

* M25U receivers may be wired for either of two speed modes: Normal or High, depending on hookup. The Normal-Speed mode offers a sensing range of 500 mm. The Normal-Speed mode maximizes sensing energy, as is required in demanding environments. The High-Speed mode offers a sensing range of 250 mm. The High-Speed mode maximizes sensing response, as is needed in high-speed counting applications.



5-Pin

Euro-Style with Shield
Straight connector models listed;
for right-angle, add **RA** to the end
of the model number (example,
MQDEC2-506RA)

MQDEC2-506
2 m (6.5')
MQDEC2-515
5 m (15')
MQDEC2-530
9 m (30')



5-Pin

Euro-Style Washdown
Straight connector models only

MQDCWD-506
2 m (6.5')
MQDCWD-530
9 m (30')

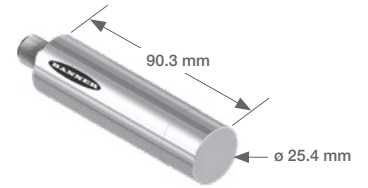

Additional cordset information is available
See page 758



SMBM25A



SMBM25B

Additional bracket information is available
See page 725

M25U Specifications

Sensing Range	Normal Speed: 500 mm High Speed: 250 mm
Ultrasonic Frequency	140KHz
Supply Voltage and Current	Emitter: 10 to 30 V dc (10% max. ripple) at less than 85 mA Receiver: 10 to 30 V dc (10% max. ripple) at less than 38 mA (exclusive of load)
Supply Protection Circuitry	Protected against reverse polarity and transient voltages
Receiver Output Configuration	Bipolar (1 NPN & 1 PNP) solid-state output; Normally Open (output is activated when an object blocks the sensing beam)
Output Rating	100 mA (each output) with short circuit protection; see Note 1 OFF-state leakage current: NPN: < 200 µA sinking PNP: < 10 µA sourcing ON-state saturation voltage: NPN: < 1.6 V @ 100 mA PNP: < 3.0 V @ 100 mA
Output Protection Circuitry	Protected against short circuit conditions
Output Response Time	Normal Speed: 4.0 milliseconds High Speed: 3.0 milliseconds
Repeatability	1 millisecond
Delay at Power-up	< 250 milliseconds
Delay for Switching Between Normal and High Speed	20 milliseconds
Indicators	Green Power LED: indicates Power ON Amber Output LED: indicates output activated
Construction	Housing: 316 Stainless Steel LED window: Polysulphone
Environmental Rating	Leakproof design, rated IEC IP67 (NEMA 6), IP69K
Operating Conditions	Temperature: -20 to +70 °C Max. Relative Humidity: 95% at 50° C non-condensing
Vibration and Mechanical Shock	All models meet Mil. Std. 202F requirements method 201A (vibration: 10 to 60 Hz max. amplitude 0.06", max. acceleration 10G). Also meets IEC 947-5-2; 30G 11 ms duration.
Notes	1. NPN < 200 µA for load impedance > 3 KΩ; for load current of 100 mA, leakage < 1% of load current 2. When mounting the M25U, care should be taken to acoustically isolate the emitter and receiver to eliminate sound energy coupling between the sensor pair. This is best accomplished with elastomeric materials between the sensor and rigid mounting brackets.
Certifications	CE

T18U Series

Opposed Dual-Range Ultrasonic Sensors



- T-style right-angle sensor package with an 18 mm threaded mounting hub, for versatile mounting
- Response time of 1 millisecond and ranges up to 600 mm suitable for high-speed applications such as counting
- Offers high immunity to electrical and acoustic noise
- Includes signal strength indicator to make alignment easy
- Ideal for small object and clear object detection

T18U

Range†	Connection	Response Time	Models NPN*	Models PNP*
NORMAL resolution: 600 mm HIGH resolution: 300 mm	2 m 4-pin Euro QD	NORMAL resolution: 2 ms HIGH resolution: 1 ms	T186UE Emitter T186UEQ Emitter	
NORMAL resolution: 600 mm HIGH resolution: 300 mm	2 m 4-pin Euro QD	NORMAL resolution: 2 ms HIGH resolution: 1 ms	T18VN6UR T18VN6URQ	T18VP6UR T18VP6URQ

 Connection options: A model with a QD requires a mating cordset.

For 9 m cable, add suffix W/30 to the 2 m model number (example, T18VN6UR W/30).

† Receivers may be wired for either resolutions: Normal or High.

* Sensor pair requires one emitter and one receiver.



Euro-Style
 Straight connector models listed; for right-angle, add **RA** to the end of the model number (example, **MQDC-406RA**)

Additional cordset information is available
 See page 758



Additional bracket information is available
 See page 723



Ultrasonic Wave Guides

Inside Diameter	Model
5.0 mm	UWG18-5.0
6.4 mm	UWG18-6.4

Additional wave guide information is available
 See page 959

T18U Specifications

Sensing Range (no minimum range)	NORMAL resolution mode: to 600 mm HIGH resolution mode: to 300 mm
Supply Voltage and Current	12 to 30 V dc, 10% max. ac ripple 50 mA (emitters); 35 mA (receivers), exclusive of output load
Ultrasonic Frequency	230 kHz
Minimum spacing (adjacent pairs)	50 mm for emitter-to-receiver separations of up to 150 mm Add 10 mm of adjacent-pair spacing for every 100 mm of emitter-to-receiver spacing beyond 150 mm
Receiver Output Configuration	T18VN models: NPN sinking, NO and NC (complementary) T18VP models: PNP sourcing, NO and NC (complementary)
Receiver Output Rating	150 mA max. each output at 25 °C, derated to 100 mA at 70 °C (derate ≈ 1 mA per °C) Both outputs may be used simultaneously. ON-state saturation voltage: less than 1.5 V at 10 mA; less than 2.0 V at 150 mA OFF-state leakage current: less than 1 µA at 30 V dc Output protection: Overload and short-circuit protected. No false pulse upon receiver power-up: false pulse protection causes a 100 millisecond delay upon power-up.
Output Response Time	NORMAL resolution mode: 2 milliseconds ON/OFF HIGH resolution mode: 1 millisecond ON/OFF
Rep Rate	NORMAL resolution mode: 125 Hz max. HIGH resolution mode: 200 Hz max.
Mechanical Sensing Repeatability at 300 mm range	NORMAL resolution mode: less than 2 mm HIGH resolution mode: less than 1 mm
Beam Angle (-3dB full angle)	15 ± 2°
Indicators	Emitters have a green LED for dc power ON. Receivers have two LEDs, one yellow and one green Solid Green: power ON Flashing Green: output overloaded Yellow: sonic signal received (flash rate is proportional to received signal strength; flash is from full to half intensity) See data sheet for detailed information
Construction	T-style yellow PBT polyester housing with black PBT polyester back cover. Transducer housing is threaded M18 x 1. Mating jam nut is supplied for mounting. Acoustic face is epoxy reinforced. Circuitry is epoxy-encapsulated.
Environmental Rating	IEC IP67; NEMA 6P
Operating Temperature	-40 to +70 °C
Vibration and Mechanical Shock	All models meet Mil.Std 202F requirements method 201A (Vibration: frequency 10 to 60 Hz, max., and double amplitude 0.06", maximum acceleration 10G) and method 213B conditions H&I (Shock: 75G with unit operation; 100G for non-operation). Also meets IEC 947-5-2 requirements: 30G, 11 milliseconds duration, half sine wave.

Certifications

Q45U Series

Versatile Ultrasonic Sensors



- The Q45U accepts programming storage cards for fast, easy sensing parameter changes with ranges up to 3 m
- Bipolar discrete models have switches for ON/OFF presence detection and HIGH/LOW level control
- In ON/OFF mode, bipolar discrete models detect when the target is within the set range or when it is outside the range
- In HIGH/LOW mode, bipolar discrete models detect when the target is outside the configured range, for fill level control, web tensioning control and similar applications
- Response time is programmed with switches in discrete models and with a potentiometer in analog models
- Push-button and remote TEACH-mode programming with an external switch, computer or controller for added security and convenience



Q45U Discrete Output, 12-24 V DC

Range	Temperature Compensation	Connection	Output Type	Response Time	Models
100 mm to 1.4 m	No	2 m	Bipolar NPN/PNP	Programmable for 20, 40, 160 or 640 ms	Q45UBB63DA Q45UBB63DAQ Q45UBB63DAQ6
		5-pin Mini QD 5-pin Euro QD			
100 mm to 1.4 m	Yes	2 m	Bipolar NPN/PNP	Programmable for 20, 40, 160 or 640 ms	Q45UBB63DAC Q45UBB63DACQ Q45UBB63DACQ6
		5-pin Mini QD 5-pin Euro QD			
250 mm to 3 m†	Yes	2 m	Bipolar NPN/PNP	Programmable for 40, 80, 320 or 1280 ms	Q45UBB63BC Q45UBB63BCQ Q45UBB63BCQ6
		5-pin Mini QD 5-pin Euro QD			



Q45U Analog Output, 15-24 V DC

Range	Temperature Compensation	Connection	Output Type	Response Time	Models
100 mm to 1.4 m	Yes	2 m	Selectable 0 to 10 V dc or 4 to 20 mA	Adjustable from 40 to 1280 ms	Q45ULIU64ACR Q45ULIU64ACRQ Q45ULIU64ACRQ6
		5-pin Mini QD 5-pin Euro QD			
250 mm to 3 m†	Yes	2 m	Selectable 0 to 10 V dc or 4 to 20 mA	Adjustable from 80 to 2560 ms	Q45ULIU64BCR Q45ULIU64BCRQ Q45ULIU64BCRQ6
		5-pin Mini QD 5-pin Euro QD			

Connection options: A model with a QD requires a mating cordset.

For 9 m cable, add suffix W/30 to the 2 m model number (example, Q45UBB63DA W/30).

† The far limit may be extended as far as 3.9 m for good acoustical targets—hard surfaces with area greater than 100 cm².



5-Pin

Euro-Style with Shield
Straight connector models listed; for right-angle, add **RA** to the end of the model number (example, **MQDEC2-506RA**)

- MQDEC2-506**
2 m (6.5')
- MQDEC2-515**
5 m (15')
- MQDEC2-530**
9 m (30')



5-Pin

Mini-Style with Shield
Straight connector models only

- MBCC2-506**
2 m (6.5')
- MBCC2-515**
5 m (15')
- MBCC2-530**
9 m (30')



SMB30A



SMB30MM



SMB30SC

Additional cordset information is available
See page 758

Additional bracket information is available
See page 722

Q45U Specifications

Sensing Range	"A" suffix: Near limit: 100 mm min. (239 kHz) "B" suffix: Near limit: 250 mm min. (128 kHz) "A" suffix: Far limit: 1.4 m max. (239 kHz) "B" suffix: Far limit: 3.0 m max. (128 kHz) NOTE: The far limit may be extended on long range units, as far as 3.9 m for good acoustical targets (hard surfaces with area greater than 100 cm ²)																				
Supply Voltage and Current	Discrete: 12 to 24 V dc (10% max. ripple); 100 mA (exclusive of load) Analog: 15 to 24 V dc (10% max. ripple); 100 mA (exclusive of load)																				
Supply Protection Circuitry	Protected against reverse polarity and transient voltages																				
Output Protection Circuitry	Protected against false pulse on power-up and continuous overload or short-circuit of outputs																				
Output Configuration	Discrete: Bipolar: One current sourcing (PNP) and one current sinking (NPN) open collector transistor Analog: One voltage sourcing and one current sourcing; one or the other output is enabled by internal programming switch #2																				
Output Ratings	Discrete: 150 mA max. (each) OFF-state leakage current: less than 25 µA at 24 V dc ON-state saturation voltage: less than 1.5 V at 10 mA; less than 2.0 V at 150 mA Analog: Voltage sourcing: 0 to 10 V dc, 10 mA max. Current sourcing: 4 to 20 mA, 1 to 500 Ω impedance																				
Performance Specifications	<table border="1"> <thead> <tr> <th></th> <th>"A" suffix</th> <th>"B" suffix</th> </tr> </thead> <tbody> <tr> <td>Analog resolution or discrete repeatability:</td> <td>± 0.1% of sensing distance (± 0.25 mm min.)</td> <td>± 0.1% of sensing distance (± 0.5 mm min.)</td> </tr> <tr> <td>Analog Linearity:</td> <td>1% of full scale</td> <td>1% of full scale</td> </tr> <tr> <td>Temperature effect:</td> <td>0.05% of sensing distance/ °C with temp. comp. 0.2% of sensing distance/ °C without temp. comp.</td> <td>0.05% of sensing distance/ °C</td> </tr> <tr> <td>Min. window size:</td> <td>10 mm</td> <td>25 mm</td> </tr> <tr> <td>Hysteresis (discrete output):</td> <td>5 mm</td> <td>10 mm</td> </tr> </tbody> </table>				"A" suffix	"B" suffix	Analog resolution or discrete repeatability:	± 0.1% of sensing distance (± 0.25 mm min.)	± 0.1% of sensing distance (± 0.5 mm min.)	Analog Linearity:	1% of full scale	1% of full scale	Temperature effect:	0.05% of sensing distance/ °C with temp. comp. 0.2% of sensing distance/ °C without temp. comp.	0.05% of sensing distance/ °C	Min. window size:	10 mm	25 mm	Hysteresis (discrete output):	5 mm	10 mm
	"A" suffix	"B" suffix																			
Analog resolution or discrete repeatability:	± 0.1% of sensing distance (± 0.25 mm min.)	± 0.1% of sensing distance (± 0.5 mm min.)																			
Analog Linearity:	1% of full scale	1% of full scale																			
Temperature effect:	0.05% of sensing distance/ °C with temp. comp. 0.2% of sensing distance/ °C without temp. comp.	0.05% of sensing distance/ °C																			
Min. window size:	10 mm	25 mm																			
Hysteresis (discrete output):	5 mm	10 mm																			
Adjustments	The following may be selected by a 4-position DIP switch. Discrete: Switch 1: Output normally open/normally closed (pump in/pump out) Switch 2: High/Low level control mode or on/off presence sensing mode Switch 3 & 4: Response speed selection (digital filter) Analog: Switch 1: Output slope positive or output slope negative Switch 2: Current output mode or voltage output mode Switch 3: Loss of echo min/max mode or loss of echo Hold Mode Switch 4: Loss of echo min/max default output value																				
Indicators	Discrete: Three status LEDs: Solid Green: power ON Flashing Green: output overloaded Yellow: outputs are conducting (Yellow LED also indicates programming status during setup mode) Red: indicates relative strength of received echo Analog: Three status LEDs: Green: power ON Flashing Green: current output fault (4-20 mA current path to ground is open) Yellow: target is sensed within the window limits (Yellow LED also indicates programming status during setup mode) Red flashing: indicates relative strength of received echo 5-segment moving dot LED indicates the position of the target within the sensing window. See data sheet for detailed information.																				
Construction	Molded PBT polyester thermoplastic polyester housing, o-ring sealed transparent acrylic top cover, and stainless steel hardware. Q45U sensors are designed to withstand 1200 psi washdown. The base of cabled models has a ½"-14NPS internal conduit thread.																				
Environmental Rating	Leakproof design is rated IEC IP67; NEMA 6P																				
Operating Conditions	Temperature: -25 to +70 °C Relative humidity: 100%																				
Vibration and Mechanical Shock	All models meet Mil. Std. 202F requirements. Method 201A (Vibration: 10 to 60Hz max., double amplitude 0.06", maximum acceleration 10G). Method 213B conditions H & I (Shock: 75G with unit operating; 100G for non-operation). Also meets IEC 947-5-2 requirements: 30G, 11 milliseconds duration, half sine wave.																				
Application Notes	"A" suffix: Min. target size: 10 x 10 mm aluminum plate at 500 mm 35 x 35 mm aluminum plate at 1.4 m "B" suffix: Min. target size: 50 x 50 mm aluminum plate at 3 m Discrete: Enable/Disable; Connect yellow wire to +5 to 24 V dc to enable sensor and 0 to +2 V dc to disable sensor. When the sensor is disabled, the last output state is held until the sensor is re-enabled. The wire must be held to the appropriate voltage for at least 40 milliseconds for the sensor to enable or disable.																				
Certifications																					



Q45UR Series

Remote Transducer Ultrasonic Sensors





- Q45 housing with an available plastic or a stainless steel 18 mm threaded barrel sensing head or an ultra-compact plastic Flat-Pak sensing head
- The Q45UR has sensing ranges up to 250 mm
- Resolution/repeatability +/- 0.2% of sensing distance
- Analog models feature a selectable positive or negative output slope
- Environmental rating is IEC IP65 and NEMA 4
- Push-button and remote TEACH-mode programming with an external switch, computer or controller for added security and convenience

Q45UR Discrete Output, 12-24 V DC

Sensor Range	Controller Connection	Controller Output	Kit Models	Kit Includes: Controller & Sensor	
50 to 250 mm	2 m	Bipolar NPN/PNP	Q45UR3BA63CK	 M18C2.0 Stainless Steel Barrel	
	5-pin Mini QD		Q45UR3BA63CQK		Q45UR3BA63CQ
	5-pin Euro QD		Q45UR3BA63CQ6K		Q45UR3BA63CQ6
50 to 250 mm	2 m	Bipolar NPN/PNP	Q45UR3BA63CKQ	 Q13C2.0 Flat-Pak	
	5-pin Mini QD		Q45UR3BA63CQKQ		Q45UR3BA63CQ
	5-pin Euro QD		Q45UR3BA63CQ6KQ		Q45UR3BA63CQ6
50 to 250 mm	2 m	Bipolar NPN/PNP	Q45UR3BA63CKS	 S18C2.0 Molded Barrel	
	5-pin Mini QD		Q45UR3BA63CQKS		Q45UR3BA63CQ
	5-pin Euro QD		Q45UR3BA63CQ6KS		Q45UR3BA63CQ6



Q45UR Analog Output, 15-24 V DC

Sensor Range	Controller Cable	Controller Output	Kit Models	Kit Includes: Controller & Sensor	
50 to 250 mm	2 m		Q45UR3LIU64CK	 M18C2.0 Stainless Steel Barrel	
	5-pin Mini QD		Q45UR3LIU64CQK		Q45UR3LIU64CQ
	5-pin Euro QD		Q45UR3LIU64CQ6K		Q45UR3LIU64CQ6
50 to 250 mm	2 m	Selectable 0 to 10 V dc or 4 to 20 mA	Q45UR3LIU64CKQ	 Q13C2.0 Flat-Pak	
	5-pin Mini QD		Q45UR3LIU64CQKQ		Q45UR3LIU64CQ
	5-pin Euro QD		Q45UR3LIU64CQ6KQ		Q45UR3LIU64CQ6
50 to 250 mm	2 m		Q45UR3LIU64CKS	 S18C2.0 Molded Barrel	
	5-pin Mini QD		Q45UR3LIU64CQKS		Q45UR3LIU64CQ
	5-pin Euro QD		Q45UR3LIU64CQ6KS		Q45UR3LIU64CQ6

Connection options: A model with a QD requires a mating cordset.

For 9 m cable, add suffix W/30 to the 2 m model number (example, Q45UR3BA63CK W/30).



Euro-Style with Shield
Straight connector models listed; for right-angle, add **RA** to the end of the model number (example, **MQDEC2-506RA**)

5-Pin
MQDEC2-506
2 m (6.5')
MQDEC2-515
5 m (15')
MQDEC2-530
9 m (30')



5-Pin
MBCC2-506
2 m (6.5')
MBCC2-512
4 m (12')
MBCC2-530
9 m (30')

Mini-Style with Shield
Straight connector models only



SMB30A



SMB30MM



SMB30SC

Additional bracket information is available
See page 722

Q45UR High-Gain Controllers

Version	Model
Discrete	63060 Q45UR3BA63CQ6-63060
Analog	63667 Q45UR3LIU64CQ6-63667

NOTE: Special High-Gain controllers are available for small object detection.
Contact factory for more information.

Q45UR Remote Sensors Specifications

Supply Voltage and Current	Discrete: 12 to 24 V dc (10% max. ripple); 100 mA (exclusive of load)	Analog: 15 to 24 V dc (10% max. ripple); 100 mA (exclusive of load)
Ultrasonic Frequency	400 kHz	
Supply Protection Circuitry	Protected against reverse polarity and transient voltages	
Output Protection Circuitry	Both outputs are protected against continuous overload and short circuit	
Output Rating	Discrete: 150 mA max. (each output) OFF-state leakage current: less than 25 µA at 24 V dc ON-state saturation voltage: less than 1.5 V at 10 mA;	Analog: Voltage sourcing: 0 to 10 V dc, 10 mA max. Current sourcing: 4 to 20 mA, 1 to 500 Ω impedance
Output Configuration	Discrete: Bipolar: One current sourcing (PNP) and one current sinking (NPN) open collector transistor	Analog: One voltage sourcing and one current sourcing; one or the other output is enabled by internal programming switch #2
Performance Specifications	Discrete: Response Speed: 40 or 160 ms (switch selectable) Repeatability*: ±0.2% of measured distance Temperature stability: ±0.03% of the window limit positions per °C from 0 to 50 °C, (±0.05% per °C over remainder of operating temperature range) Sensing window width: 5 to 200 mm, when independent near and far limits are taught; 1, 2, 3, or 4 mm (switch selectable), when a sensing distance set point is taught Hysteresis: 0.5 mm Ultrasonic beam angle: ±3.5°	Analog: Response Speed: 10 to 320 ms (2 to 64 cycles) selectable Resolution*: 0.2% of sensing distance at 320 ms response, 0.4% of sensing distance a 10 ms response Linearity*: 1% of full scale Temperature stability: ±0.03% of sensing distance per °C from 0 to 50 °C, (±0.05% per °C over remainder of operating temperature) Ultrasonic beam angle: ±3.5°
	* Repeatability and analog resolution and linearity are specified using a 50 x 50 mm aluminum plate at 22° C under fixed sensing conditions (Analog: using the 4 to 20 mA output @ 15 V dc)	
Adjustments	Discrete: The following may be selected by a 4-position DIP switch Switch 1: Output normally open (output is energized when target is within sensing window limits), or normally closed (output is energized when target is outside sensing window limits) Switches 2 & 3: Sensing window size (1, 2, 3 or 4 mm) Switch 4: Response speed selection (40 or 160 milliseconds)	Analog: Push-button TEACH-mode programming of window limits. The following may be selected by a 4-position DIP switch located on top of the controller, beneath a transparent o-ring sealed acrylic cover and beneath the black inner cover. Switch 1: Output slope: output value increases or decreases with distance Switch 2: Output mode: current output or voltage output Switches 3 & 4: Response to loss of echo Response Speed Adjustment: Single-turn potentiometer selects six response values from 10 to 320 milliseconds
Indicators	Discrete: Three status LEDs: Green: Power ON Yellow: Output are conducting (Yellow also indicates programming status during setup) Red: Relative strength of received echo 5-segment moving dot LED indicates the position of the target within the sensing window	Analog: Three status LEDs: Solid Green: Power ON Flashing Green: current output fault (4-20 mA current path to ground is open) Yellow: Target is sensed within the window limits (Yellow LED also indicates programming status during setup mode) Red: Relative strength of received echo 5-segment moving dot LED indicates the position of the target within the sensing window (See data sheet for detailed information)
Construction	Controller: Molded thermoplastic polyester housing, o-ring sealed transparent acrylic top cover, and stainless steel hardware Sensors: M18C2.0: Stainless steel M18 threaded barrel housing and jam nuts, polyetherimide front cover, ceramic transducer, polyurethane rear cover S18C2.0: Thermoplastic polyester S18 threaded barrel housing and jam nuts, polyetherimide front cover, ceramic transducer, polyurethane rear cover Q13C2.0: Molded 30% glass reinforced thermoplastic polyester housing, ceramic transducer, fully epoxy-encapsulated	
Environmental Rating	Controller: IEC IP67; NEMA 6P	Sensor: IEC IP65; NEMA 4
Operating Conditions	Controller and sensor: -25 to +70 °C	Relative humidity: 85% (non-condensing)
Vibration and Mechanical Shock	All models meet Mil. Std. 202F requirements. Method 201A Vibration: 10 to 60Hz max., double amplitude 0.06" (maximum acceleration 10G). Method 213B conditions H & I (Shock: 75G with unit operating; 100G for non-operation). Also meets IEC 947-5-2 requirements: 30G, 11 milliseconds duration, half sine wave.	
Certifications	CE	

QS18U Series

Right-Angle Ultrasonic Sensors



- Senses clear and transparent materials, as well as color variations, including clear web material, clear or shiny bottles, highly reflective surfaces and liquid or dry bulk materials inside cramped locations
- Sensing range up to 500 mm.
- Features a universal housing with an 18 mm threaded lens or side mount
- Available in encapsulated IP68 models rated for a range of harsh conditions
- Push-button and remote TEACH-mode programming with an external switch, computer or controller for added security and convenience

QS18U

Range	Connection	TEACH Options	Models NPN	Models PNP
50 to 500 mm	2 m	Integral push button and remote TEACH (IP67; NEMA 6P)	QS18UNA	QS18UPA
	4-pin Euro QD		QS18UNAQ8	QS18UPAQ8
50 to 500 mm	2 m	Remote TEACH (epoxy-encapsulated, IP68; NEMA 6P)	QS18UNAE*	QS18UPAE*
	4-pin Euro QD		QS18UNAEQ8*	QS18UPAEQ8*

* Models are epoxy-encapsulated, IP68; NEMA 6P with remote TEACH programming

 Connection options: A model with a QD requires a mating cordset.

For 9 m cable, add suffix W/30 to the 2 m model number (example, QS18UNA W/30).

QD models:

- For 4-pin integral Euro-style QD, add suffix Q8 (example, QS18UNAQ8).
- For 4-pin 150 mm Euro-style pigtail, add suffix Q5 (example, QS18UNAQ5).
- For 4-pin integral Pico-style QD, add suffix Q7 (example, QS18UNAQ7).
- For 4-pin 150 mm Pico-style pigtail, add suffix Q (example, QS18UNAFQ).



Euro-Style with Shield
Straight connector models listed; for right-angle, add **RA** to the end of the model number (example, **MQDEC2-406RA**)

4-Pin

MQDEC2-406
2 m (6.5')

MQDEC2-415
5 m (15')

MQDEC2-430
9 m (30')



Pico-Style with Shield

Straight 4-Pin

PKG4S-2
2 m (6.5')

Right-Angle 4-Pin

PKW4ZS-2
2 m (6.5')

Additional cordset information is available
See page 758





SMB18A **SMB18FA..** **SMB1815SF**

Additional bracket information is available
See page 722

Ultrasonic Wave Guides



Inside Diameter	Model
5.0 mm	UWG18-5.0
6.4 mm	UWG18-6.4

Additional wave guide information is available
See page 959



QS18U Specifications

Sensing Range	50 to 500 mm	
Supply Voltage and Current	12 to 30 V dc (10% max. ripple); 25 mA max. (exclusive of load)	
Ultrasonic Frequency	300 kHz, rep. rate 7.5 milliseconds	
Supply Protection Circuitry	Protected against reverse polarity and transient voltages	
Output Protection	Protected against short circuit conditions	
Delay at Power-Up	300 milliseconds	
Output Configurations	Solid-state switch conducts when target is sensed within sensing window; one NPN (current sinking) or one PNP (current sourcing), depending on model	
Temperature Effect	Non-encapsulated models: ± 0.05% per °C from -20 to +50 °C, ± 0.1% per °C from +50 to +60 °C Encapsulated models: ± 0.05% per °C from 0° to +60° C, ± 0.1% per °C from -20° to 0° C	
Repeatability	0.7 mm	
Hysteresis	1.4 mm	
Output Ratings	100 mA max. (see Application Note 1) OFF-state leakage current: less than 10 µA (sourcing); less than 200 µA (sinking); See Application Note 2 NPN ON-state saturation voltage: less than 1.6 V @ 100 mA PNP ON-state saturation voltage: less than 3.0 V @ 100 mA	
Output Response Time	15 milliseconds	
Minimum Window Size	5 mm	
Adjustments	Sensing window limits: TEACH-Mode programming of near and far window limits may be set using the push button or remotely using TEACH input	
Indicators	Range Indicator (Red/Green) Green: Target is within sensing range Red: Target is outside sensing range OFF: Sensing power is OFF	Teach/Output Indicator (Yellow/Red) Yellow: Target is within taught limits OFF: Target is outside taught window limits Red: Sensor is in TEACH mode
Construction	Housing: ABS Push Button: TPE	Push Button Housing: ABS Lightpipes: Polycarbonate
Environmental Rating	Leakproof design, rated IEC IP67 or IP68; NEMA 6P, depending on model; UL type 1	
Operating Conditions	Temperature: -20 to +60 °C	Relative humidity: 100% (non-condensing)
Vibration and Mechanical Shock	All models meet Mil. Std. 202F requirements method 201A (vibration: 10 to 60 Hz max., double amplitude 0.06", maximum acceleration 10G). Also meets IEC 947-5-2 requirements: 30G 11 milliseconds duration, half sine wave.	
Temperature Warmup Drift	See data sheet	
Application Notes	1. If supply voltage is > 24 V dc, derate maximum output current 5 mA/ °C above 50 °C. 2. NPN OFF-state leakage current is < 200 µA for load resistances > 3 kΩ or optically isolated loads. For load current of 100 mA, leakage is < 1% of load current. 3. Objects passing inside the specified near limit may produce a false response.	

Certifications



K50U Series

Ultrasonic Sensor for Wireless Level and Tank Monitoring



- Three meter sensing range with a 300 mm dead zone
- Provides a distance measurement from the target to the sensor
- Built-in temperature compensation
- Rugged design for demanding sensing environments; rated IEC IP67, NEMA 6P
- Functions as a Modbus slave device using RS-485

K50U

Range and Frequency	Supply Voltage	I/O	Models
Range: 300 mm to 3 m Frequency: 114 kHz	3.6 to 5.5 V dc	Distance to target using a 1-wire serial interface	K50UX1RA
Range: 300 mm to 3 m Frequency: 114 kHz	3.6 to 5.5 V dc or 10 to 30 V dc	Distance to target using Modbus RS-485	K50UX2RA



5-Pin

Euro-Style
Double-ended, straight male to female

- DEE2R-51D**
0.31 m (1')
- DEE2R-53D**
0.91 m (3')
- DEE2R-58D**
2.44 m (8')

Additional cordset information is available
See page 758



BWA-BK-006

Mounts both the K50U Ultrasonic sensor and a Wireless Q45 Node





K50U Specifications

Supply Voltage and Current	3.6 to 5.5 V dc or 10 to 30 V dc
Current	Active comms: 11.3 mA at 30 V dc
Indicators	Two LEDs
Performance	Sensing range: 300 mm to 3 m (11.8 in to 118 in) Ultrasonic frequency: 114 kHz Temperature effect: 0.02% of distance/°C Resolution: 0.1% of distance (1.5 mm minimum)
Discrete Inputs	300 milliseconds
Output Configurations	One Sinking Rating: 3 mA max current at 30 V dc ON Condition: Less than 0.7 V OFF Condition: Greater than 2 V or open
Communication Protocol	Modbus RTU
Communication Hardware	RS-485 Serial Baud Rates: 9.6k, 19.2k (default), or 38.4k Data Format: 8 data bits, No parity (default), even parity, or odd parity 1 stop bit Do not use a termination resistor
Communications Line	Level Receive ON: Greater than 2 V Level Receive OFF: Less than 0.7 V Level Transmit ON: 2.7 to 3 V Level Transmit OFF: 0 V (pulldown resistor of 10 kOhm)
Construction	Housing: PBT polyester Transducer: Epoxy/ceramic composite
Environmental Rating	Leakproof design, rated IEC IP67 (NEMA 6)
Operating Conditions	Temperature: -40 to +70 °C Relative humidity: 95% at +50 °C maximum relative humidity (non-condensing)
Vibration and Mechanical Shock	All models meet Mil Std. 202F requirements. Method 201A (vibration: 10 Hz to 60 Hz max., double amplitude 0.06 inch, maximum acceleration 10G). Also meets IEC 947-5-2 requirements: 30G 11 ms duration, half sine wave
Certifications	



Radar

Radar sensors use Frequency Modulated Continuous Wave (FMCW) radar to reliably detect moving or stationary targets, including cars, trains, trucks and cargo in rain, snow, high and low temperatures and wind.

Series	Description	Max. Sensing Range	Beam Angle	Outputs	Dimensions H x W x D	Power Supply
	Q120R FMCW Radar dual-zone, narrow-beam, high-sensitivity, sensor ideal for port crane anticollision and train detection. page 242	40 m	24° x 50°	DIP-switch-selectable NPN or PNP; N.O. or N.C.	159.5 x 90.8 x 62 mm	12 to 30 V dc
	Q240RA Radar-based dual-zone narrow-beam sensors for detection of moving and stationary targets page 243	100 m	11° x 13°	DIP-switchselectable NPN or PNP; N.O. or N.C.	186.9 x 159.9 x 55.5 mm	12 to 30 V dc
	QT50R FMCW Radar wide-beam easy-to-configure sensor ideal for traffic monitoring, ships, tollways, and car parking. page 244	24 m	90° x 76°	Bipolar NPN/PNP; DIP switch-selectable N.O. or N.C.	100.2 x 74.1 x 46.1 mm	12 to 30 V dc

Q120R Series

Radar-Based Adjustable-Field Sensor



- Radar-based narrow-beam sensors with high sensitivity for detection of moving and stationary targets
- Unaffected by wind, falling rain or snow, fog, humidity, air temperatures or light.
- FMCW (true-presence) radar detects moving and stationary objects
- 1 or 2 independent, adjustable sensing zones
- Easy setup and configuration of range, sensitivity and output with simple DIP switches
- Cordsets and brackets available see page 245

Q120R Narrow Beam (24° x 50°)

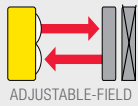
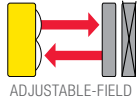
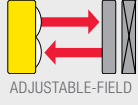
Sensing Mode	Max Range†	Connection	Telecom Approval*	Output	Model
 ADJUSTABLE-FIELD	12 m	5-pin M12 QD	US, Canada and Brazil	Bipolar NPN/PNP	Q120RA-US-AFQ
			Europe, UK, Australia, New Zealand, Japan and China	Selectable NO or NC	Q120RA-EU-AFQ
			South Korea		Q120RA-KR-AFQ
 ADJUSTABLE-FIELD	40+ m	5-pin M12 QD	US, Canada and Brazil	(2) Selectable Dual NPN/PNP	Q120RA-US-AF2Q
			Europe, UK, Australia, New Zealand, Japan and China	Selectable NO or NC	Q120RA-EU-AF2Q
			South Korea		Q120RA-KR-AF2Q
 ADJUSTABLE-FIELD	26 m	5-pin M12 QD	US and Canada	(2) Selectable Dual NPN/PNP	Q120RA-US-AF2WQ
			Europe, UK, Australia, New Zealand, Japan and China	Selectable NO or NC	Q120RA-EU-AF2WQ
			South Korea		Q120RA-KR-AF2WQ

For more specifications see page 245.

 QD models: A model with a QD requires a mating cordset (see page 245).

Cabled models: For cabled models, omit Q at the end of the QD model (example, Q120RA-US-AF2).

† Range is dependent on target object.

* Contact factory at 1-888-373-6767 for additional information.

Q240R Series

Radar-Based Adjustable-Field Sensor



- Radar-based sensor has a very narrow beam pattern, making it an extremely robust solution for applications where users need to monitor a specific area without detecting adjacent objects
- FMCW (true-presence) radar detects moving and stationary objects
- Narrow beam pattern, high sensitivity, and long range
- Easy setup and configuration of range, sensitivity and output with simple DIP switches
- Two independent adjustable sensing zones (far and near proximity warning signal)
- Cordsets and brackets available see page 245

Q240R Narrow Beam (11° x 13°)

Sensing Mode	Max Range†	Connection	Telecom Approval*	Output	Model
 ADJUSTABLE-FIELD	40+ m	5-pin M12 QD	US, Canada and Brazil	(2) Selectable Dual NPN/PNP	Q240RA-US-AF2Q
			Europe, UK, Australia, New Zealand and Japan	Selectable NO or NC	Q240RA-EU-AF2Q
			China		Q240RA-CN-AF2Q
 ADJUSTABLE-FIELD	100 m	5-pin M12 QD	US and Canada	(2) Selectable Dual NPN/PNP	Q240RA-US-AF2LQ
			Europe, UK, Australia, New Zealand and Japan	Selectable NO or NC	Q240RA-EU-AF2LQ
			China		Q240RA-CN-AF2LQ
 ADJUSTABLE-FIELD	100 m	5-pin M12 QD	US and Canada	(1) 0-10 V Analog and (1) Selectable NPN/PNP	Q240RA-US-ULQ
			Europe, UK, Australia, New Zealand and Japan	Selectable NO or NC	Q240RA-EU-ULQ
			China		Q240RA-CN-ULQ
 ADJUSTABLE-FIELD	100 m	5-pin M12 QD	US and Canada	(1) 4-20 mA Analog and (1) Selectable NPN/PNP	Q240RA-US-ILQ
			Europe, UK, Australia, New Zealand and Japan	Selectable NO or NC	Q240RA-EU-ILQ
			China		Q240RA-CN-ILQ

For more specifications see page 245.

QD models: A model with a QD requires a mating cordset (see page 245).

Cabled models: For cabled models, omit Q at the end of the QD model (example, Q240RA-US-AF2).

† Range is dependent on target object.

* Contact factory at 1-888-373-6767 for additional information.

QT50R Series

Radar-Based Sensor



- Sensor's functions are unaffected by wind, rain, fog, light, humidity and temperature, making it ideal for outdoor environments
- Uses Frequency Modulated Continuous Wave (FMCW) to detect moving and stationary objects
- Easy setup and configuration of range, sensitivity and output with simple DIP switches
- Retroreflective models use a reference target, enabling reliable detection of weak targets in the foreground
- Adjustable-field models ignore objects beyond the set point

QT50R Wide Beam (90° x 76°)

Sensing Mode	Max Range [†]	Connection	Telecom Approval*	Output	Model
 ADJUSTABLE-FIELD	24 m	5-pin M12 QD	US, Canada and Brazil Europe, UK, Australia, New Zealand, Japan and China South Korea Taiwan	Bipolar NPN/PNP Selectable NO or NC	QT50R-US-AFHQ QT50R-EU-AFHQ QT50R-KR-AFHQ QT50R-TW-AFHQ
 ADJUSTABLE-FIELD	24 m	5-pin M12 QD	US, Canada and Brazil Europe, UK, Australia, New Zealand, Japan and China South Korea Taiwan	(2) Selectable NPN/PNP Selectable NO or NC	QT50R-US-AF2Q QT50R-EU-AF2Q QT50R-KR-AF2Q QT50R-TW-AF2Q
 ADJUSTABLE-FIELD	3.75 m	5-pin M12 QD	Europe, UK, Australia, New Zealand, Japan and China South Korea	Bipolar NPN/PNP Selectable NO or NC	QT50R-EU-AFSQ QT50R-KR-AFSQ
 RETRO	12 m	5-pin M12 QD	US, Canada and Brazil Europe, UK, Australia, New Zealand, Japan and China South Korea Taiwan	Bipolar NPN/PNP Selectable NO or NC	QT50R-US-RHQ QT50R-EU-RHQ QT50R-KR-RHQ QT50R-TW-RHQ

 QD models: A model with a QD requires a mating cordset.

Cabled models: For cabled models, omit Q at the end of the QD model (example, QT50R-US-AF2W).

[†] Range is dependent on target object.

* Contact factory at 1-888-373-6767 for additional information.



5-Pin

Euro-Style
Straight connector models listed; for right-angle, add **RA** to the end of the model number (example, MQDEC2-506RA)

- MQDEC2-506
2 m (6.5')
- MQDEC2-55
5 m (15')
- MQDEC2-530
9 m (30')



SMB30A



SMB30MM

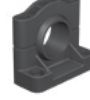

SMB30SC



SMBQ240SS1



SMBQ240SS2



SMBQ240SS3

Additional cordset information is available
See page 758

Additional bracket information is available
See page 725

Weather Deflectors



QT50RCK



SMBWSQ120



Q240WS

Retro Wave Radar Target



BRTR-CC20E



R-GAGE® QT50R

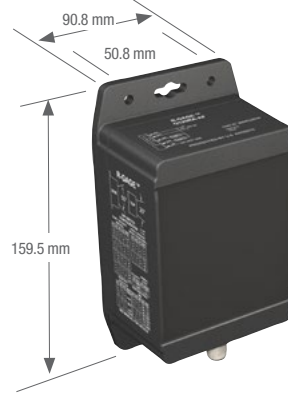

R-GAGE® Q120RA

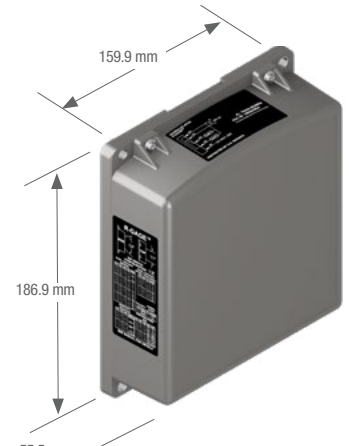

R-GAGE® Q240RA

R-GAGE® Specifications

Range	The sensor is able to detect a proper object (see Detectable Objects) from 0 to 100 m, depending on model
Detectable Objects	Objects containing metal, water or similar high-dielectric material
Operating Principle	Frequency Modulated Continuous Wave (FMCW) radar
Operating Frequency	24.00-24.25 GHz, ISM Band (varies slightly by model and national telecom regulations)
Supply Voltage	12 to 30 V dc, less than 100 mA (exclusive of load) KR models: 12 to 24 V dc
Supply Protection Circuitry	Protected against reverse polarity and transient overvoltages
Delay at Power-up	Less than 2 seconds
Output Configuration	NPN and PNP, N.O. and N.C., 150 mA each
Output Protection	Protected against short circuit conditions
Indicators	Power LED: Green (Power ON) Signal Strength LED: Red, flashes in proportion to signal strength Output LEDs: Yellow (output energized)/Red (configuration) See data sheets for more detailed information
Response Time	DIP-switch configurable ON/OFF response time
Adjustments	DIP-Switch configurable sensing distance, sensitivity, response time, and output configuration. Remote line TEACH for retroreflective models.
Construction	Housing: ABS/polycarbonate Lightpipes: Acrylic Access Cap: Polyester
Operating Temperature	-40 to +65 °C
Environmental Rating	IP67

Certifications





For more information regarding telecom approvals consult datasheet



Arrays

Using an array of closely spaced light beams, measuring light screens are designed for profiling, inspections and process monitoring.

Series	Description	Minimum Object Detection Size	Dimensions H x W x D	Protection Rating	Housing Material	Power Supply
	<p>EZ-ARRAY™ Two piece measuring array page 248</p>	5 mm	H (varies by model) 36 x 45.2 mm	IP65	Aluminum with clear anodized finish	12 to 30 V dc
	<p>MINI ARRAY® For inspections and profiling with a long range page 252</p>	19.1 mm	H (varies by model) 38.1 x 38.1 mm	IP65	Aluminum with black anodized finish	Controller: 16 to 30 V dc
	<p>High Res MINI ARRAY® Excels at high-speed, precise monitoring and inspection applications page 256</p>	2.5 mm	H (varies by model) 38.1 x 38.1 mm	IP65	Aluminum with black anodized finish	Controller: 16 to 30 V dc

EZ-ARRAY™

Two-Piece Measuring Light Screens



- Two-piece light-screen design eliminates the need for a separate controller
- 5 mm beam spacing provides edge resolution of 2.5 mm
- High excess gain option for detecting opaque objects in single and double edge scan mode
- Seven zone LEDs provide instant alignment and beam blockage information
- Remote TEACH capable
- Rugged aluminum housing

EZ-ARRAY™, 12-30 V DC, 5 mm Beam Spacing

Housing Length (L)	Array Length	Total Beams	Range*	Analog Output	Emitter Model	Receiver Model NPN Outputs	Receiver Model PNP Outputs
227 mm	150 mm	30	0.4 to 4 m	Current (4 to 20 mA) Voltage (0 to 10 V)	EA5E150Q	EA5R150NIXMODQ EA5R150NUXMODQ	EA5R150PIXMODQ EA5R150PUXMODQ
379 mm	300 mm	60		Current (4 to 20 mA) Voltage (0 to 10 V)	EA5E300Q	EA5R300NIXMODQ EA5R300NUXMODQ	EA5R300PIXMODQ EA5R300PUXMODQ
529 mm	450 mm	90		Current (4 to 20 mA) Voltage (0 to 10 V)	EA5E450Q	EA5R450NIXMODQ EA5R450NUXMODQ	EA5R450PIXMODQ EA5R450PUXMODQ
678 mm	600 mm	120		Current (4 to 20 mA) Voltage (0 to 10 V)	EA5E600Q	EA5R600NIXMODQ EA5R600NUXMODQ	EA5R600PIXMODQ EA5R600PUXMODQ
828 mm	750 mm	150		Current (4 to 20 mA) Voltage (0 to 10 V)	EA5E750Q	EA5R750NIXMODQ EA5R750NUXMODQ	EA5R750PIXMODQ EA5R750PUXMODQ
978 mm	900 mm	180		Current (4 to 20 mA) Voltage (0 to 10 V)	EA5E900Q	EA5R900NIXMODQ EA5R900NUXMODQ	EA5R900PIXMODQ EA5R900PUXMODQ
1128 mm	1050 mm**	210		Current (4 to 20 mA) Voltage (0 to 10 V)	EA5E1050Q	EA5R1050NIXMODQ EA5R1050NUXMODQ	EA5R1050PIXMODQ EA5R1050PUXMODQ
1278 mm	1200 mm**	240		Current (4 to 20 mA) Voltage (0 to 10 V)	EA5E1200Q	EA5R1200NIXMODQ EA5R1200NUXMODQ	EA5R1200PIXMODQ EA5R1200PUXMODQ
1578 mm	1500 mm**	300		Current (4 to 20 mA) Voltage (0 to 10 V)	EA5E1500Q	EA5R1500NIXMODQ EA5R1500NUXMODQ	EA5R1500PIXMODQ EA5R1500PUXMODQ
1878 mm	1800 mm**	360		Current (4 to 20 mA) Voltage (0 to 10 V)	EA5E1800Q	EA5R1800NIXMODQ EA5R1800NUXMODQ	EA5R1800PIXMODQ EA5R1800PUXMODQ
2178 mm	2100 mm**	420		Current (4 to 20 mA) Voltage (0 to 10 V)	EA5E2100Q	EA5R2100NIXMODQ EA5R2100NUXMODQ	EA5R2100PIXMODQ EA5R2100PUXMODQ
2478 mm	2400 mm**	480		Current (4 to 20 mA) Voltage (0 to 10 V)	EA5E2400Q	EA5R2400NIXMODQ EA5R2400NUXMODQ	EA5R2400PIXMODQ EA5R2400PUXMODQ

For more specifications see page 251.

 QD models: A model with a QD requires a mating cordset (see page 252).

* Models with a range of 300 mm to 1500 mm models are available upon request. Contact factory at 1-888-373-6767 for more information.

** Models with array lengths 1050 mm and longer ship with a center bracket and two end-cap brackets.

EZ-ARRAY™ IO-Link, 0-10 V DC–5 mm Beam Spacing

Housing Length (L)	Array Length	Total Beams	Range*	Emitter Model	Receiver Model PNP Outputs
227 mm	150 mm	30	0.4 to 4 m	EA5E150Q	EA5R150XKQ
379 mm	300 mm	60		EA5E300Q	EA5R300XKQ
529 mm	450 mm	90		EA5E450Q	EA5R450XKQ
678 mm	600 mm	120		EA5E600Q	EA5R600XKQ
828 mm	750 mm	150		EA5E750Q	EA5R750XKQ
978 mm	900 mm	180		EA5E900Q	EA5R900XKQ
1128 mm	1050 mm**	210		EA5E1050Q	EA5R1050XKQ
1278 mm	1200 mm**	240		EA5E1200Q	EA5R1200XKQ
1578 mm	1500 mm**	300		EA5E1500Q	EA5R1500XKQ
1878 mm	1800 mm**	360		EA5E1800Q	EA5R1800XKQ
2178 mm	2100 mm**	420		EA5E2100Q	EA5R2100XKQ
2478 mm	2400 mm**	480		EA5E2400Q	EA5R2400XKQ

For more specifications see page 251.

 QD models: A model with a QD requires a mating cordset (see page 252).

* Models with a range of 300 mm to 1500 mm models are available upon request. Contact factory at 1-888-373-6767 for more information.

** Models with array lengths 1050 mm and longer ship with a center bracket and two end-cap brackets.

MEASUREMENT

LASER

ULTRASONIC

RADAR

M12/Euro-Style

Straight connector models listed; for right-angle, add **RA** to the end of the model number (example, **MAQDC-815RA**)



8-Pin
MAQDC-815
 4 m (13')
MAQDC-830
 9 m (30')
MAQDC-850
 15 m (49')

Communication Cordsets

Straight connector models listed; for right-angle, add **RA** to the end of the model number (example, **MQDMC-506RA**)



5-Pin
MQDMC-506
 2 m (13')
MQDMC-515
 4 m (13')
MQDMC-530
 9 m (30')

Double-Ended Euro-Style

Male/female straight Euro QD connectors



8-Pin	
DEE2R-81D	DEE2R-825D
0.31 m (1.0')	7.62 m (25.0')
DEE2R-83D	DEE2R-850D
0.91 m (3.0')	15.3 m (50.0')
DEE2R-88D	DEE2R-875D
2.44 m (8.0')	22.9 m (75.0')
DEE2R-815D	DEE2R-8100D
4.57 m (15.0')	30.5 m (100.0')

Additional cordset information is available
 See page 758

For IO-Link splitters see datasheet

Serial Adapters



EZA-MBK-20



SMBLBCZB



EZA-USB485-01



INTUSB485-1

Additional bracket information is available
 See page 725

Additional adapter information is available
 See page 819

Stands



Additional information is available
 See page 802

Enclosures



Additional information is available
 See page 808

Lens Shields



Additional information is available
 See page 812



EZ-ARRAY Light Screen

W = 36.0 mm D = 45.2 mm
 L = Length (see model chart page 255)

EZ-ARRAY™ Specification

Supply Voltage (Limit Values)	Emitter: 12 to 30 V dc Receiver Analog Current Models: 12 to 30 V dc Receiver Analog Voltage Models: 15 to 30 V dc IO-Link receiver: 18 to 30 V dc
Supply Power Requirements	Emitter/Receiver Pair (Exclusive of discrete load): Less than 9 watts Power-up delay: 2 seconds
Emitter/Receiver Range	400 mm to 4 m
Field of View	Nominally ± 3°
Beam Spacing	5 mm
Light Source	Infrared LED
Minimum Object Detection Size	Straight Scan, Low-Contrast: 5 mm Straight Scan, High-Excess-Gain: 10 mm
Sensor Positional Resolution	Straight Scan: 5 mm Double-Edge Scan: 2.5 mm Single-Edge Scan: 2.5 mm
Teach Input (Receiver Gray Wire)	Low: 0 to 2 volts High: 6 to 30 volts or open (input impedance 22 kΩ)
Two Discrete Outputs	Solid-State NPN or PNP (current sinking or sourcing) Rating: 100 mA max. each output OFF-State Leakage Current: NPN: less than 200 uA @ 30 V dc PNP: less than 10 uA @ 30 V dc ON-State Saturation Voltage: NPN: less than 1.6 V @ 100 mA PNP: less than 2.0 V @ 100 mA Protected against false pulse on power-up and continuous overload or short circuit. IO-Link Model: Discrete Output 1 (SIO Mode) Type: Solid-State Push-Pull Rating: 100 mA maximum (sourcing or sinking) ON-State Saturation Voltage: less than 3V @100mA (sourcing or sinking)
Two Analog Outputs	Voltage Sourcing: 0 to 10 V (maximum current load of 5 mA) Current Sourcing: 4 to 20 mA (maximum resistance load = (Vsupply-3)/0.020)
Serial Communication Interface	EIA-485 Modbus RTU (up to 15 nodes per communication ring) RTU binary format Baud Rate: 9600, 19.2K or 38.4K IO-Link Baud Rate: 38,400 bps (COM2) 8 Data Bits, 1 Stop Bit, and Even, Odd, or 2 Stop Bits and No Parity Process data width: 16 bits
Scan Time	Scan times depend on scan mode and sensor length. Straight scan times range from 2.8 to 26.5 milliseconds.
Status Indicators	Emitter: Red Status LED ON Steady—Status Flashing at 1 hz—Error IO-Link: Green: IO-Link OK Yellow flashing: IO-Link Comm Solid Red: IO-Link error Receiver: 7 Zone Indicators Red—Blocked channels within zone Green—All channels clear within zone 3-digit 7-segment indicators for measurement mode/diagnostic information Sensor Status Bicolor Indicator LED Red—Hardware Error or Marginal Alignment Green—OK Modbus Activity Indicator LED: Yellow Modbus Error Indicator LED: Red
System Configuration (Receiver Interface)	6-position DIP switch: Used to set scanning type, measurement modes, analog slope and discrete output 2 function. Alternate software GUI interface provides additional options; see full manual. Push Buttons: Two momentary push buttons for alignment and gain level selection IO-Link models: Supplied IODD files provide all configuration options (see manual)
Connections	Serial communication: The receiver uses a PVC-jacketed, 5-conductor 22-gauge quick-disconnect cable, 5.4 mm diameter. QD cordsets are ordered separately. Other Sensor connections: 8-conductor quick-disconnect cordsets (one each for emitter and receiver), ordered separately (may not exceed 75 m long), PVC-jacketed cordsets measure 5.8 mm diameter, have shield wire; 22-gauge conductors.
Construction	Aluminum housing with clear-anodized finish; acrylic lens cover
Environmental Rating	IEC IP65
Operating Conditions	Temperature: -40 to +70 °C Relative humidity: 95% at 50 °C (non-condensing)
Certification	 

MINI-ARRAY® Series

Measuring Light Screens

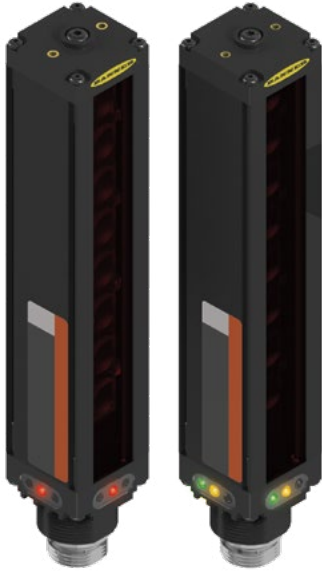

The MINI-ARRAY® is a programmable measuring light screen for inspections and profiling with a long range up to 16.5 m.

- Offers programmable controller with a selection of measurement modes, scan modes and output configurations
- Available with 9.5 or 19 mm beam spacing for detecting objects as small as 12.7 mm
- Advanced software GUI
- Highly visible indicators for status monitoring

MINI-ARRAY® 19.1 mm Beam Spacing

Max Range	Minimum Object Size	Total Beams	3-Piece Models*			2-Piece Models		
			Length (L)	Emitter	Receiver	Length (L)	Emitter	Receiver
16.5 m	Interlaced Mode: 25.4 mm Other scan modes: 38.1 mm	8	201 mm	BMEL616A	BMRL616A	231 mm	MAE616Q	MAR616NX485Q
		16	356 mm	BMEL1216A	BMRL1216A	384 mm	MAE1216Q	MAR1216NX485Q
		24	505 mm	BMEL1816A	BMRL1816A	536 mm	MAE1816Q	MAR1816NX485Q
		32	659 mm	BMEL2416A	BMRL2416A	689 mm	MAE2416Q	MAR2416NX485Q
		40	810 mm	BMEL3016A	BMRL3016A	841 mm	MAE3016Q	MAR3016NX485Q
		48	963 mm	BMEL3616A	BMRL3616A	993 mm	MAE3616Q	MAR3616NX485Q
		56	1115 mm	BMEL4216A	BMRL4216A	1146 mm	MAE4216Q	MAR4216NX485Q
13.5 m	Interlaced Mode: 25.4 mm Other scan modes: 38.1 mm	64	1267 mm	BMEL4816A	BMRL4816A	1298 mm	MAE4816Q	MAR4816NX485Q
		72	-	-	-	1451 mm	MAE5416Q	MAR5416NX485Q
		80	1572 mm	BMEL6016A	BMRL6016A	1514 mm	MAE6016Q	MAR6016NX485Q
		88	-	-	-	1667 mm	MAE6616Q	MAR6616NX485Q
		96	1877 mm	BMEL7216A	BMRL7216A	1819 mm	MAE7216Q	MAR7216NX485Q

For more specifications see page 255.

 QD models: A model with a QD requires a mating cordset (see page 254).

* One controller and an emitter/receiver pair (of matching length and resolution) required per system.

MINI-ARRAY® 9.5 mm Beam Spacing

Max Range	Minimum Object Size	Total Beams	Length (L)	3-Piece Models*		2-Piece Models		
				Emitter	Receiver	Length (L)	Emitter	Receiver
6.1 m	Interlaced Mode: 12.7 mm Other scan modes: 19.1 mm	16	201 mm	BMEL632A	BMRL632A	231 mm	MAE632Q	MAR632NX485Q
		32	356 mm	BMEL1232A	BMRL1232A	384 mm	MAE1232Q	MAR1232NX485Q
		48	505 mm	BMEL1832A	BMRL1832A	536 mm	MAE1832Q	MAR1832NX485Q
		64	659 mm	BMEL2432A	BMRL2432A	689 mm	MAE2432Q	MAR2432NX485Q
		80	810 mm	BMEL3032A	BMRL3032A	841 mm	MAE3032Q	MAR3032NX485Q
		96	963 mm	BMEL3632A	BMRL3632A	993 mm	MAE3632Q	MAR3632NX485Q
		112	1115 mm	BMEL4232A	BMRL4232A	1146 mm	MAE4232Q	MAR4232NX485Q
		128	1267 mm	BMEL4832A	BMRL4832A	1298 mm	MAE4832Q	MAR4832NX485Q
4.6 m	Interlaced Mode: 12.7 mm Other scan modes: 19.1 mm	144	-	-	-	1451 mm	MAE5432Q	MAR5432NX485Q
		160	1572 mm	BMEL6032A	BMRL6032A	1603 mm	MAE6032Q	MAR6032NX485Q
		176	-	-	-	1755 mm	MAE6632Q	MAR6632NX485Q
		192	1877 mm	BMEL7232A	BMRL7232A	1908 mm	MAE7232Q	MAR7232NX485Q

MINI-ARRAY® Controllers*, 16-30 V DC

Inputs	Solid-State Discrete Outputs	Analog Outputs	Serial Output	Controller Models
1 Sensor pair & Trigger (Gate)	1 Reed & 1 NPN	-	RS-232 & RS-485	MAC-1
	2 NPN	-		MACN-1
	2 PNP	-		MACP-1
	1 NPN	(2) 0-10 V Sourcing	RS-232	MACV-1
	1 NPN	(2) 4-20 mA Sinking		MACI-1
1 Sensor pair & Trigger (Gate)	16 NPN	-	RS-232	MAC16N-1
	16 PNP	-		MAC16P-1

For more specifications see page 255.

 QD models: A model with a QD requires a mating cordset (see page 254).
* One controller and an emitter/receiver pair (of matching length and resolution) required per 3-piece system.

Used with 2-Piece Arrays

Used with 3-Piece Arrays

Euro-Style with Shield
Straight connector models only



8-Pin
MAQDC-806
2 m (6')
MAQDC-8015
4.5 m (15')
MAQDC-830
9 m (30')
MAQDC-850
15 m (50')

Communication Cordsets

Straight connector models listed; for right-angle, add **RA** to the end of the model number (example, **MQDMC-506RA**)



5-Pin
MQDMC-506
2 m (13')
MQDMC-515
4 m (13')
MQDMC-530
9 m (30')



DIN-35-..



MSMB-3

Additional bracket information is available
See page 725

Additional cordset information is available
See page 758

Stands



Additional information is available
See page 802

Enclosures



Additional information is available
See page 808

Lens Shields



Additional information is available
See page 812

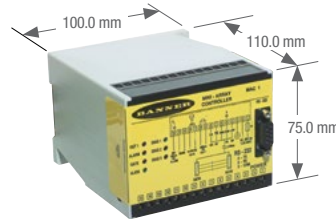

MINI-ARRAY Controller

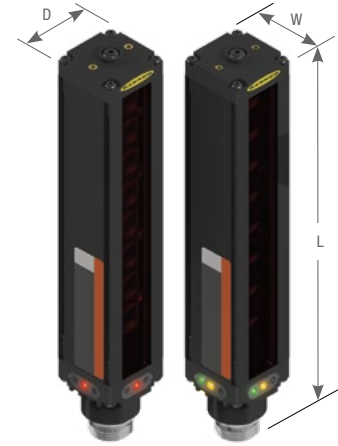



MINI-ARRAY Sensors

W = 38.1 mm D = 38.1 mm
L = Length (see model chart)



MINI-ARRAY® 3-Piece Set, Emitter/Receiver Specifications

Max Emitter/Receiver Range	9.5 mm beam spacing: Length 201 to 1115 mm: 6.1 m Length 1267 to 1877 mm: 4.6 m	19.1 mm beam spacing: Length 201 to 1115 mm: 16.5 m Length 1267 to 1877 mm: 13.5 m
Minimum Object Sensitivity	9.5 mm Beam Spacing: Straight, Edge Modes: 19.1 mm Interlaced Mode: 12.7 mm* Skip Mode: Multiply the above by the number of skipped beams, plus 1 Interlaced Mode: 12.7 mm*	19.1 mm Beam Spacing: Straight, Edge Modes: 38.1 mm Interlaced Mode: 25.4 mm* Skip Mode: Multiply the above by the number of skipped beams, plus 1 Interlaced Mode: 25.4 mm*
*Assumes sensing is in the middle 1/3 of sensing range		
Sensor Scan Time	55 microseconds per beam, plus 1 millisecond post process time per scan	
Power Requirements †Maximum current is for a 6' sensor	9.5 mm beam spacing: 12 V dc ±2%, supplied by controller Emitter: 0.10 A @ 12 V dc Receiver: 0.75 A @ 12 V dc†	19.1 mm beam spacing: 12 V dc ±2%, supplied by controller Emitter: 0.10 A @ 12 V dc Receiver: 0.50 A @ 12 V dc†
Status Indicators	Emitter: Red LED lights to indicate proper emitter operation Receiver: Green indicates sensors aligned (> 3x excess gain) Amber indicates marginal alignment of one or more beams (1x -3x excess gain) Red indicates sensors misaligned or one or more beam(s) blocked	
Construction	Aluminum, with black anodized finish; acrylic lens cover	
Environmental Rating	NEMA 4, 13; IP65	
Certification		

MINI-ARRAY® 3-Piece Set, Controller Specifications

Power Requirements	16 to 30 V dc @ 1.25 amps max. (see current requirements for sensors); controller alone, (without sensors connected) requires 0.1 amp.	
Inputs	Sensor input (5 connections): Emitter and receiver wire in parallel to five terminals Trigger (Gate) input: Optically isolated, requires 10 to 30 V dc (7.5K input impedance) for gate signal	
Discrete Outputs	MACN-1: (2) Open collector NPN transistor outputs MAC16P-1: Sixteen open collector PNP transistor outputs	MAC16N-1: Sixteen open collector NPN transistor outputs 30 V dc max., 150 mA max., short circuit protected OFF-state leakage current: less than 10 µA ON-state saturation voltage: less than 1 V @ 10 mA; less than 1.9 V @ 150 mA
Serial Data Outputs	RS-232, ASCII or binary data format Baud Rate: 9600, 19.2K, or 38.4K, 8 data bits, 1 start bit, 1 stop bit, even parity Clear data may be suppressed Header string may be suppressed in binary format	
Analog Outputs	Resolution: Span/(Number of sensor channels) Linearity: 0.1% of Full Scale	Temperature variation: 0.01% of Full Scale/ °C
Controller Programming	Via RS-232 PC-compatible computer running Windows XP, 2000, Vista, Windows 7 or Windows 8 and using Banner supplied software	
Sensor Scan Time	All models: 55 microseconds per beam plus processing time Processing time is dependent on the scan analysis and the number of active outputs. This timing assumes a straight scan, continuous, and TBB mode MACN-1: 1 millisecond processing time MAC16N-1 & MAC16P-1: 2.3 to 7 milliseconds processing time	
System Response Time	Outputs are not active for 5 seconds after system power up. Maximum response time for the system is two sensor scan cycles. A scan cycle includes a sensor scan plus any serial data transmission. Serial transmission (if activated) follows every sensor scan.	
Status Indicators	The following status LEDs are located on the top surface of the module: MACN-1: OUT 1 (Red) - Indicates that output 1 is energized MAC16N-1 & MAC16P-1: OUT (Red) - Indicates that at least one output is active ALARM (Red) - Indicates that Output 2 is active/MAC16N-1 & MAC16P-1: Indicates output 16 is active GATE (Red) - Indicates voltage is applied to Trigger (Gate) input ALIGN (Green) - Indicates sensor aligned (excess gain > 1x) DIAG1 (Green) - Indicates power is applied to the module DIAG2 (Red) - Indicates receiver failure DIAG3 (Red) - Indicates emitter failure	
Construction	Polycarbonate	
Environmental Rating	NEMA 1; IP20	
Operating Conditions	Temperature: -20 to +70 °C	Relative humidity: 95% (non-condensing)
Certifications	 	

MINI-ARRAY® 2-Piece Set, Emitter/Receiver Specifications

Emitter/Receiver Range	9.5 mm beam spacing: Array Length 231 to 1146 mm: 6.1 m Array Length 1298 to 1908 mm: 4.6 m	19.1 mm beam spacing: Array Length 231 to 1146 mm: 16.5 m Array Length 1298 to 1908 mm: 13.5 m
Minimum Object Sensitivity	9.5 mm Beam Spacing: Straight, Edge Modes: 19.1 mm Interlaced Mode: 12.7 mm* Skip Mode: Multiply the above by the number of skipped beams, plus 1 Interlaced Mode: 12.7 mm*	19.1 mm Beam Spacing: Straight, Edge Modes: 38.1 mm Interlaced Mode: 25.4 mm* Skip Mode: Multiply the above by the number of skipped beams, plus 1 Interlaced Mode: 25.4 mm*
	*Assumes sensing is in the middle 1/3 of sensing range	
Sensor Scan Time	0.9-27.1 ms depending on scan mode, array length and beam spacing	
Supply Voltage and Power	16 V dc to 30 V dc; maximum power 12 watts	
Status Indicators	Emitter: Red LED lights to indicate proper emitter operation Receiver: Green indicates sensors aligned (> 3x excess gain) Amber indicates marginal alignment of one or more beams (1x -3x excess gain) Red indicates sensors misaligned or one or more beam(s) blocked	
Construction	Aluminum, with black anodized finish; acrylic lens cover	
Environmental Rating	NEMA 4, 13; IP65	
Certification	 	

High Resolution MINI-ARRAY®

High-Resolution Measuring Light Screens

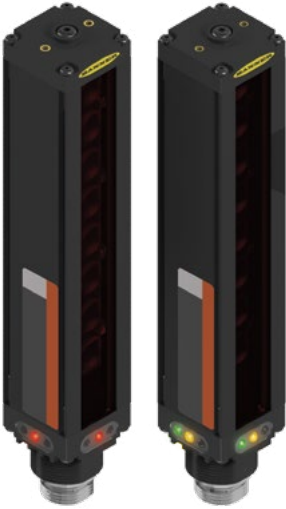

- Offers programmable controller with a selection of measurement modes scan modes and output configurations
- 120 sensing beams per foot provides reliable detection of objects as small as 2.5 mm
- Features a 1.8 m range and easy alignment
- Advanced software GUI
- Highly visible indicators for status monitoring

High-Resolution MINI-ARRAY®, 2.5 mm Beam Spacing

Housing Length (L)	Array Length	Total Beams	Connection	Range	Minimum Object Size	Models*	
						Emitters	Receivers
236 mm	163 mm	64	5-pin Mini QD	0.4 to 1.8 m	2.5 mm	MAHE6A	MAHR6A
399 mm	325 mm	128				MAHE13A	MAHR13A
561 mm	488 mm	192				MAHE19A	MAHR19A
724 mm	650 mm	256				MAHE26A	MAHR26A
887 mm	813 mm	320				MAHE32A	MAHR32A
1049 mm	975 mm	384				MAHE38A	MAHR38A
1215 mm	1138 mm	448				MAHE45A	MAHR45A
1377 mm	1300 mm	512				MAHE51A	MAHR51A
1540 mm	1463 mm	576				MAHE58A	MAHR58A
1703 mm	1626 mm	640				MAHE64A	MAHR64A
1865 mm	1788 mm	704				MAHE70A	MAHR70A
2028 mm	1951 mm	768				MAHE77A	MAHR77A

For more specifications see page 258.

 QD models: A model with a QD requires a mating cordset.

* "E" and "R" in model numbers denotes "Emitter" and "Receiver" respectively. Sold separately.

High-Resolution MINI-ARRAY® Controllers†, 16-30 V DC

Inputs	Solid-State Discrete Outputs	Analog Outputs	Serial Output	Controller Models
1 Sensor pair & Trigger (Gate)	2 PNP	(2) 0 to 10 V Sourcing	RS-232 & RS-485	MAHCVP-1
	2 NPN	(2) 0 to 10 V Sourcing		MAHCVN-1
	2 PNP	(2) 4 to 20 mA Sinking		MAHCIP-1
	2 NPN	(2) 4 to 20 mA Sinking		MAHCIN-1



† One controller and an emitter/receiver pair (of matching length) required per system.

Mini-Style Cordsets
Straight connector models only



- 5-Pin**
- QDC-515C**
5 m (15')
 - QDC-525C**
8 m (25')
 - QDC-550C**
15 m (50')
 - MAQDC-575C**
23 m (75')
 - MAQDC-5100C**
30.5 m (100')
 - MAQDC-5150C**
45.5 m (150')

DB9 Communication Cordset

9-Pin MASC
2 m (13')



DIN-35-..

MSMB-3

Additional bracket information is available
See page 725

Additional cordset information is available
See page 758

Stands



Additional information is available
See page 802

Enclosures



Additional information is available
See page 808

Lens Shields



Additional information is available
See page 812



MINI-ARRAY Sensors

W = 38.1 mm D = 38.1 mm
L = Length (see model chart page 256)

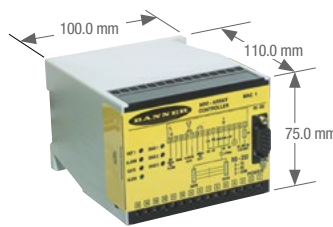

MINI-ARRAY Controller

High-Resolution MINI-ARRAY® Emitter/Receiver Specifications

Emitter/Receiver Range	380 mm to 1.8 m
Minimum Object Sensitivity	2.5 mm
Sensor Scan Time	1.8 to 58.4 milliseconds, depending on scanning method and sensor length plus 1 millisecond post processing time for controller
Power Requirements	12 V dc \pm 2%, supplied by controller
Connections	Sensors connect to controller using two 5-conductor quick-disconnect cordset (one each for emitter and receiver), ordered separately. Use only Banner cordset, which incorporate a "twisted pair" for noise immunity. Cordsets measure 8.1 mm in diameter and are shielded and PVC-jacketed. Conductors are 20 gauge (0.9 mm). Emitter and receiver cordset may not exceed 75 m long, each. See page 257.
Status Indicators	Emitter: Red LED lights to indicate proper emitter operation Receiver: Green indicates sensors aligned Yellow indicates marginal alignment of one or more beams Red indicates sensors misaligned or one or more beam(s) blocked
Construction	Aluminum, with black anodized finish; acrylic lens cover
Environmental Rating	NEMA 4, 13; IP65
Operating Conditions	Temperature: 0 to +50 °C Relative humidity: 95% at 50 °C (non-condensing)
Certifications	



High-Resolution MINI-ARRAY® Controller Specifications

Power Requirements	16 to 30 V dc @ 1.0 A (typical: 0.5 A @ 16 V dc)
Inputs	Sensor input: Emitter and receiver wire in parallel to five terminals Trigger (Gate) input: Optically isolated, requires 10 to 30 V dc (7.5 kΩ impedance) for gate signal Remote alignment input: Optically isolated, requires 10 to 30 V dc (7.5 kΩ impedance) for alignment sequence signal
Discrete (Switched) Outputs	NPN outputs: Open collector NPN transistor rated at 30 V dc max., 150 mA max. PNP outputs: Open collector PNP transistor rated at 30 V dc max., 150 mA max. All discrete outputs: OFF-state leakage current: less than 10 μA @ 30 V dc ON-state saturation voltage: less than 1 V @ 10 mA; less than 1.5 V @ 150 mA
Serial Data Outputs	RS-232 or RS-485 interface. (Up to 15 control modules may be given unique addresses on one RS-485 party line.) ASCII or binary data format 9600, 19.2K or 38.4K baud rate 8 data bits 1 stop bit, and even, odd or no parity
Analog Outputs	Voltage-sourcing outputs: 0 to 10 V dc (25 mA current limit) Current-sinking outputs: 4 to 20 mA (16 to 30 V dc input) Resolution: Span / Number of sensing channels Linearity: 0.1% of full scale Temperature variation: 0.01% of full scale per °C
Output Configuration	MAHCVP-1: Two PNP discrete (switched), two 0-10 V voltage sourcing MAHCVN-1: Two NPN discrete (switched), two 0-10 V voltage sourcing MAHCIP-1: Two PNP discrete (switched), two 4-20 mA current sinking MAHCIN-1: Two NPN discrete (switched), two 4-20 mA current sinking
System Programming	Via RS-232 interface to PC-compatible computer running Windows® XP, Vista, Windows 7, Windows 8 and using software supplied with each control module
Status Indicators	Output 1 (Red): Lights to indicate Discrete Output #1 is active Alarm (Red): Lights to indicate Discrete Output #2 is active Gate (Red): Lights to indicate Trigger (Gate) is active Align (Green): Lights to indicate emitter and receiver are aligned Diagnostics indicator: (Key on controller side label) Identifies System errors and status
Construction	Polycarbonate housing; mounts to flat surface or directly onto 35 mm DIN rail
Environmental Rating	NEMA 1; IP20
Operating Conditions	Temperature: 0 to +50 °C Relative humidity: 95% @ 50 °C (non-condensing)
Certifications	



Temperature & Vibration

Temperature sensors detect small differences between the temperature of an object and the surrounding ambient temperature. Vibration and temperature sensor measures RMS velocity, in inches per second or millimeters per second, and temperature.

Series	Description	Minimum Object Detection Range	Dimensions H x W x D	Protection Rating	Housing Material	Power Supply
	<p>M18T Works on moving or still products by detecting infrared energy that objects emit. page 262</p>	1 m	18 mm ø x (varies by model)	IP67 NEMA 6	Stainless Steel	12 to 30 V dc
	<p>M12F Designed to work as a Modbus slave device via RS-485 or with Sure Cross® Wireless products page 264</p>	264	12 mm ø x (varies by model)	IP67 NEMA 6	Metal	12 to 24 V dc 3.6 to 5.5 V dc
	<p>QM42VT Provides high accuracy vibration (velocity RMS) and temperature measurements page 266</p>		42 x 13 x 42 mm	IP67 NEMA 6	Zinc alloy	3.6 to 5.5 V dc

M18T Series

Non-Contact Temperature Sensors



- Senses temperature differences as small as 3 °C, on moving or still products
- Senses from 0 to 300 °C
- Allows threshold adjustment and real-time information display through a PC
- Requires no emitter or controller
- Uses remote or push-button programming

M18T

Sensing Face	D:S Ratio*	Output	Connection	Models
Integrated lens	8:1	0 to 10 V dc analog, plus PNP Alarm	2 m	M18TUP8
			5-pin Euro QD	M18TUP8Q
Enclosed Plastic face (for food industry use)	6:1	0 to 10 V dc analog, plus PNP Alarm	2 m	M18TUP6E
			5-pin Euro QD	M18TUP6EQ
Germanium lens	14:1	0 to 10 V dc analog, plus PNP Alarm	2 m	M18TUP14
			5-pin Euro QD	M18TUP14Q
Integrated lens	8:1	4 to 20 mA analog, plus PNP Alarm	2 m	M18TIP8
			5-pin Euro QD	M18TIP8Q
Enclosed Plastic face (for food industry use)	6:1	4 to 20 mA analog, plus PNP Alarm	2 m	M18TIP6E
			5-pin Euro QD	M18TIP6EQ
Germanium lens	14:1	4 to 20 mA analog, plus PNP Alarm	2 m	M18TIP14
			5-pin Euro QD	M18TIP14Q

 Connection options: A model with a QD requires a mating cordset.

For 9 m cable, add suffix W/30 to the 2 m model number (example, M18TUP8 W/30).

* For a sensor with an 8:1 D:S ratio, the sensor's spot size is a 1" diameter circle at a distance of 8"

M12/Euro-Style with Shield

Straight connector models listed; for right-angle, add **RA** to the end of the model number (example, **MQDEC2-506RA**)



5-Pin

- MQDEC2-506**
2 m (6.5')
- MQDEC2-515**
5 m (15')
- MQDEC2-530**
9 m (30')



SMB18A



SMB18SF



SMB18UR

*Additional cordset information is available
See page 758*

*Additional bracket information is available
See page 723*



APC-18
Air Purge Collar
(sensor not included)



LAT1812
Laser Alignment Tool



Cabled Models (L)

M18T..Q8	81.3 mm
M18T..6EQ	81.7 mm
M18T..14Q	86.5 mm



QD Models (L)

M18T..Q8	91.3 mm
M18T..6EQ	91.8 mm
M18T..14Q	96.6 mm

M18T Specifications

Supply Voltage and Current	12 to 30 V dc
Wavelength	8 to 14 μ m
Supply Protection Circuitry	Protected against reverse polarity and transient voltages
Output Response Time	75 ms (for a 95% step change)
Delay at Power-up	1.5 second
Repeatability	\pm 1% of measurement, or \pm 1 $^{\circ}$ C, whichever is greater
Construction	Threaded Barrel: Stainless steel Housing: ABS/PC
Environmental Rating	IEC IP67; NEMA 6
Sensing Field of View	See datasheet
Performance Curves	See datasheet
Operating Conditions	Temperature: -20 to +70 $^{\circ}$ C
Certifications	CE

M12F Series

Temperature and Humidity Sensors



- Manufactured with a robust metal housing
- Designed to work as a Modbus slave device via RS-485 or with Sure Cross® 1-wire serial interface -P6 nodes, -H6 MultiHop Radios, or Q45 Sensor Node DX80N2Q45TH
- Ships with aluminum grill filter cap; optional stainless steel 10 micrometer sintered filter available separately

M12FTH Temperature and Humidity

I/O	Power	Connection	Models
RS-485 Modbus	3.6 to 5.5 V dc low power option or 12 to 24 V dc	5-pin Euro QD	M12FTH3Q
1-wire serial interface	3.6 to 5.5 V dc		M12FTH4Q

M12FT Temperature

I/O	Power	Connection	Models
RS-485 Modbus	3.6 to 5.5 V dc low power option or 12 to 24 V dc	5-pin Euro QD	M12FT3Q
1-wire serial interface	3.6 to 5.5 V dc		M12FT4Q



Double Ended M12/Euro-Style with Shield
 Straight connector models only straight male to straight female

5-Pin
DEE2R-51D 0.3 m (1')
DEE2R-53D 1 m (3')
DEE2R-58D 2.5 m (8')

Additional cordset information is available See page 758

Filter Caps



FTH-FIL-001
 Aluminum Grill Filter Cap



FTH-FIL-002
 Stainless Steel Filter Cap

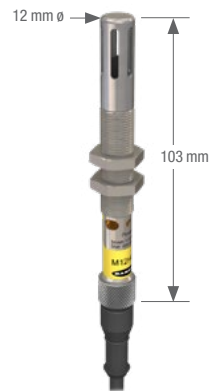

M12F Specifications

Supply Voltage and Current	3.6 to 5.5 V dc low power option or 12 to 24 V dc
Resolution	Humidity: 0.1% relative humidity Temperature: 0.1 °C
Construction	Housing: metal
Environmental Rating	IEC IP67; NEMA 6
Operating Conditions	Temperature: -40 °C to +85 °C
Certifications	 c Us CSA: Class I, Division 2, Groups A, B, C, D — Certificate 1921239

QM42VT Series

Vibration and Humidity Sensors



- Provides high accuracy vibration (velocity RMS) and temperature measurements
- Manufactured with a robust zinc alloy housing
- Connects via a 1-wire serial interface
- Reduces labor costs by obviating manual checks and eliminating error

QM42VT

I/O	Power	Connection	Models
1-Wire Serial	3.6 to 5.5 V dc	3 m	QM42VT1
RS-485 Modbus	3.6 to 5.5 V dc low power option or 10 to 24 V dc	3 m	QM42VT2

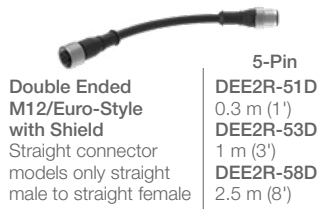

Double Ended
M12/Euro-Style
with Shield
Straight connector
models only straight
male to straight female

5-Pin
DEE2R-51D
0.3 m (1')
DEE2R-53D
1 m (3')
DEE2R-58D
2.5 m (8')

Additional cordset information is available
See page 758



RS-485 to
USB Adaptor

BWA-HW-006



RS-485 to
USB Adaptor

BWA-USB1WIRE-001



BWA-BK-002



BWA-BK-001



QM42VT Specifications

Supply Voltage and Current	3.6 to 5.5 V dc or 10 to 24 V dc
Vibration	<p>Mounted base resonance: 5.5 kHz nominal</p> <p>Measuring range: 0-46 mm/sec or 0-1.8 in/sec RMS</p> <p>Frequency Range: 10 – 1000 Hz</p> <p>Accuracy: ± 10% @25 °C</p>
Temperature	<p>Measuring range: -40 to +105 °C (-40 to +221 °F)</p> <p>Resolution: 0.1 °C Accuracy: ±3 °C</p>
Construction	Housing: Zinc alloy
Shock	400G
Environmental Rating	IEC IP67; NEMA 6
Operating Conditions	Temperature: -40 to +105 °C

Certifications 



Special Purpose

Special purpose sensors provide a variety of choices for challenging environments and applications where standard sensors don't make the cut. From hazardous areas and heavy duty washdown environments to sensing specific colors and temperatures for maximum accuracy, special purpose sensors meet specific application needs.

SPECIAL PURPOSE

BARCODE READERS **page 270**

REGISTRATION, COLOR &
LUMINESCENCE **page 282**

STAINLESS STEEL **page 296**

CLEAR OBJECT **page 312**



TEMPERATURE **page 324**

HAZARDOUS AREA **page 328**



Barcode Readers

Able to decode over a dozen commonly used 1D and 2D barcode symbols, provides fast read rates, wide depth of field, and high resolution.

Series	Description	Max Sensing Range	Dimensions (H x W x D)	Housing Material	Power Supply
	<p>iVu BCR Easy to set up, powerful, affordable inspection solution solves a wide variety of simple and complex applications. page 272</p>	Varies by selected lens	95.3 x 81.2 x 53.2 mm	Black PBT	10-30 V dc
	<p>P4 BCR Find and decode 2D and 1D linear bar codes. page 278</p>	Varies by selected lens	124.5 x 66.8 x 34.3 mm	Black anodized aluminum	10-30 V dc
	<p>Laser Barcode Scanner Can detect over a dozen of the most commonly used linear barcode symbols with a fast reading rate. page 280</p>	600 mm	68 x 83.4 x 32.8 mm	Black anodized aluminum	10-30 V dc

iVu BCR and iVu Plus BCR

Bar Code Reader (BCR)



- Powerful, affordable inspection solution solves a wide variety of simple and complex applications
- Solve a variety of linear and 2D bar code applications
- First-time users can have it up and running in minutes
- Optional remote touch screen for programming
- Ability to change parameters on the fly
- iVu BCR Plus models have Ethernet communication available and is capable of storing and controlling up to 30 inspections for fast product change over

iVu BCR Applications

Bar Code Type

- No PC required to configure, change or monitor
- Built-in or remote touch screen
- Self-contained sensor with easy configuration and convenient monitoring right on the sensor



Installation and configuration in four easy steps

1. Install and connect the sensor
2. Select the sensor or bar code type, depending on model
3. Acquire a good image
4. Set inspection parameters



Intuitive operation with menu driven tools to guide you through setup

- Define region of interest
- Adjust intensity/contrast
- Define the pass criteria



Reading a 1D barcode

Screen Interface Pass



Screen Interface Fail



Reading a 2D barcode

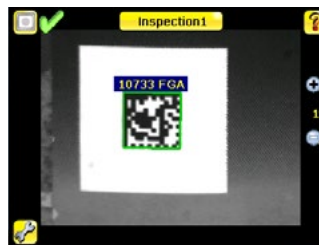

Conducts high-performance reading of industry standard barcodes.

Reads up to ten 1D and 2D bar codes at one time.

2D Bar Codes
Data Matrix (ECC200)
QR & Micro QR

1D Bar Codes
Code 128 EAN-13 (UPC-A) Postnet
Code 39 EAN-8 Pharmicode
Codabar UPC-E
Interleaved 2 of 5 IMB

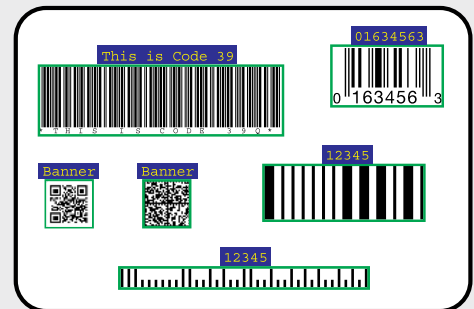



iVu BCR (Barcode Reader)

Example Model Number: IVU2PRBR04

Family	Touch Screen	Ring Light Color	Lens (mm)
IVU2P	RB	R	04
IVU2 = Reads 1D and 2D IVU2P = Reads 1D and 2D with Ethernet and storage for 30 inspections	TB = Integrated RB = Remote	R = Red B = Blue G = Green W = White I = Infrared 6 = UV365 9 = UV395 XC = C-mount* X = No Ring Light	04 = 4.3 06 = 6 08 = 8 12 = 12 16 = 16 25 = 25 Blank = No lens (only C-Mount)

* Requires C-mount lens. For C-Mount lenses see page 362

Power M12/Euro-Style with Shield Straight connector models listed; for right-angle, add RA to the end of the model number (example, MQDC2S-1206RA)		12-Pin MQDC2S-1206 2 m (6.5') MQDC2S-1215 5 m (15') MQDC2S-1230 9 m (30') MQDC2S-1250 15 m (50')	USB Straight connector models listed		8-Pin Euro** MQDEC-8005-USB 0.15 m (0.5') MQDEC-801-USB 0.3 m (1') MQDEC-803-USB 0.9 m (3') MQDEC-810-USB 3 m (10')	4-Pin Pico PSG-4M-4005-USB 0.15 m (0.5') PSG-4M-401-USB 0.3 m (1') PSG-4M-403-USB 0.9 m (3') PSG-4M-410-USB 3 m (10')
Ethernet RJ45 to 4-Pin Pico QD		4-Pin IVUC-E-406 2 m (6.5') IVUC-E-415 5 m (15') IVUC-E-430 9 m (30')	IVUC-E-450 12 m (50') IVUC-E-475 23 m (75')	Used with: BCR with Integrated Touch Screen	Used with: BCR with Remote Touch Screen and BCR Plus with Remote or Integrated Touch Screen	** For right-angle, add RA to the middle of the model number (example, MQDEC-8005RA-USB)

Additional cordset information is available. See page 758



SMBIVURAL SMBIVURAR SMBIVUB SMBIVUU
Used with: iVu BCR and iVu Plus BCR

Additional bracket information is available. See page 726

For more specifications see page 277.

Display and cordsets ordered separately.
 Remote display is required for set up and viewing of sensors with a remote touch screen.

Remote Display Touch Screen

Description	Model
3.5" diagonal remote touch screen — Machine-mountable	RDM35
3.5" diagonal remote touch screen — Handheld	RD35

RDM35 Accessory Kits



RDM35
Machine-mountable Remote Display
Used for- programming & monitoring

Description	Straight	Right-Angle
1 m cordset, bracket/docking station, stylus and hardware	IVURDM-QDK-803	IVURDM-QDK-803RA
2 m cordset, bracket/docking station, stylus and hardware	IVURDM-QDK-806	IVURDM-QDK-806RA
5 m cordset, bracket/docking station, stylus and hardware	IVURDM-QDK-815	IVURDM-QDK-815RA
9 m cordset, bracket/docking station, stylus and hardware	IVURDM-QDK-830	IVURDM-QDK-830RA
16 m cordset, bracket/docking station, stylus and hardware	IVURDM-QDK-850	IVURDM-QDK-850RA

RD35 Accessory Kits



RD35
Handheld Remote Display
Used for- programming

Description	Straight	Right-Angle
1 m cordset, bracket/docking station, stylus and hardware	IVURD-MXK-803	IVURD-MXK-803RA
2 m cordset, bracket/docking station, stylus and hardware	IVURD-MXK-806	IVURD-MXK-806RA
5 m cordset, bracket/docking station, stylus and hardware	IVURD-MXK-815	IVURD-MXK-815RA
9 m cordset, bracket/docking station, stylus and hardware	IVURD-MXK-830	IVURD-MXK-830RA
16 m cordset, bracket/docking station, stylus and hardware	IVURD-MXK-850	IVURD-MXK-850RA

Cordsets for Remote Display

Hand Held Remote Display (RD35)		Machine Mountable Remote Display (RDM35)	
8-Pin		8-Pin	
Double Ended M12/Euro-Style Straight connector models listed; for right-angle, add RA to the end of the model number (example, IVURD-QD-803RA)	IVURD-QD-803 1 m (3') IVURD-QD-806 2 m (6') IVURD-QD-815 5 m (15') IVURD-QD-830 9 m (30') IVURD-QD-850 16 m (50')	Euro-Style to Molex Straight connector models listed; for right-angle, add RA to the end of the model number (example, IVURD-MX-803RA)	IVURD-MX-803 1 m (3') IVURD-MX-806 2 m (6') IVURD-MX-815 5 m (15') IVURD-MX-830 9 m (30') IVURD-MX-850 16 m (50')

*Additional cordset information is available
See page 773*

Brackets for Remote Display



SMBRD35



SMBKS



SMBRDM35

Lenses



Lens	Model
4.3 mm	LMF04
6 mm	LMF06
8 mm	LMF08
12 mm	LMF12
16 mm	LMF16
25 mm	LMF25*

Used with: iVu and iVu Plus

* 25 mm filter holder is purchased separately

Filter Kits†



Used with: iVu and iVu Plus

* Blue band-pass filters are preinstalled on ultraviolet ringlight models
 ** Infrared band-pass filters are preinstalled on infrared ring light models
 † Filter kits include 1 color and two sizes of filter holders

Filter

Filter	Model
Red	FLTMR2
Blue	FLTMB*
Green	FLTMG
Infrared	FLTMI**

Replacement Windows

Focusing ring with optically clear glass
 Focusing ring with plastic window
 Replacement cover for touch screen

Model

IVUW-G
IVUW
IVUBC

Used with: iVu and iVu Plus

Sensor Interface Module



IVUSIM
 For simplified wiring of iVu sensors in an electrical box

2 GB USB Drive



IVU-USBFD2

Stylus



Model

STYLUS-1 (Qty 1)
STYLUS-10 (Qty 10)

C-Mount Lens Covers



Description	Model
Lens cover 50 mm — plastic window	IVUSLC50-P
Lens cover 75 mm — plastic window	IVUSLC75-P



Additional C-mount Lens information is available
 See page 362

Accessories for C-Mount Lenses*

Description	Format Size	Model	Used With
Extension Kit (0.5, 1.0, 5.0, 10, 20 and 40 mm)	—	LEK	All Lenses
Extension Kit (0.25 and 0.5 mm)		LEKS	
Lens Extender (increases focal length 2X)		LCF2X	
UV Lens Filter, Clear Glass	2/3"	FLTUV	Tamron Megapixel Lenses



Bandpass Filters

Example Model Number: FLTB470-27

Description	Model	Diameter
Blue	FLTB470-	25.5
Green	FLTG525-	
Infrared	FLTI850-	27
Red	FLTR635-	30.5
Dark Red	FLTR660-	34
Polarizing Filter	FLTPR032-	43

C-Mount Color Filters*



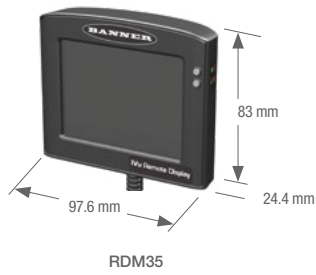

Color	Description	Plastic Models	Glass Models
Infrared	High-pass filter blocks visible light and passes infrared light. Included with all Banner Infrared light sources.	FLTI (> 760 nm)	FLTI850 (810-990 nm)
Blue	Band-pass filter improves quality by helping to reduce ambient light; it passes blue and infrared light.	FLTB (400-525 nm)	FLTB470 (435-490 nm)
Green	Band-pass filter improves quality by helping to reduce ambient light; it passes green and infrared light.	FLTG (400-575 nm)	FLTG525 (495-565 nm)
Red	High-pass filter improves quality by helping to reduce ambient light; it passes red and infrared light.	FLTR (> 600 nm)	FLTR635 (600-660 nm)
Dark Red	High-pass filter improves quality by helping to reduce ambient light; it passes red and infrared light.	—	FLTR660 (650-680 nm)

* For C-Mount lenses see page 362



iVu BCR & iVu Plus BCR Specifications

General	
Supply Voltage	10-30 V dc
Demo Mode	Full tool functionality on canned images
Sensor Lock	Optional password protection
Integrated Ring Light	Red, IR, Green, Blue, White, UV or no integrated ring light
Imager	1/3 inch CMOS 752 x 480 pixels; adjustable Field-of-View (FOV)
Lens Mount	M12 X 1 mm thread (c-mount lens); microvideo lens 4.3, 6, 8, 12, 16, 25 mm
Output Rating	150 mA
Exposure Time	0.1 milliseconds to 1.049 seconds
Construction	Black PBT sensor housing; acrylic window iVu Plus Integrated: Die cast zinc and Black PBT
External Strobe Output	+ 5 V dc
Environmental Rating	IP67
Model Specific	
Power Connection	iVu BCR (integrated and remote touch screen): 12-pin Euro-style (M12) male connector iVu Plus BCR (integrated and remote touch screen): 12-pin Euro-style (M12) male connector Accessory cordset required for operation; QD cordsets are ordered separately.
Supply Current	iVu BCR: 800 mA max. (exclusive of I/O load) iVu Plus BCR: 850 mA max. (exclusive of I/O load)
USB 2.0 Host	iVu BCR (integrated touch screen): 8-pin Euro-style (M12) female connector iVu BCR (remote touch screen): 4-pin Pico-style (M8) female connector iVu Plus BCR (integrated and remote touch screen): 4-pin Pico-style (M8) female connector Optional USB cordset required for operation of USB Thumb Drive. QD cordsets are ordered separately. See page 274.
Ethernet Connection	iVu Plus BCR: 4-pin Pico-style (M8) male connector. Ethernet cordsets are ordered separately. See page 274
Output Configuration	NPN or PNP, software selectable
Display	Integrated touch screen: 68.5 mm (2.7") LCD Color Integrated Display 320 x 240 pixels Remote touch screen: See RD35 Remote Display specifications
Acquisition	iVu BCR (integrated touch screen): 50 fps (frames per second) max. iVu Plus BCR (integrated and remote touch screen): 100 fps (frames per second) max. iVu BCR (remote touch screen): 50 fps (frames per second) max.
Operating conditions	Stable Ambient Temperature: BCR: 0 to + 50 °C iVu Plus BCR (integrated touch screen): 0 to +45 °C iVu Plus BCR (remote touch screen): 0 to +40 °C
Remote Display connection (Remote Touch Screen Models Only)	8-pin Euro-style (M12) female connector Accessory cordset required for remote display; QD cordsets are ordered separately.
Certifications	 NOTE: iVu Plus remote must use Euro QD power cordset for CE compliance. 

iVu Remote Display Specifications

Screen Size	3.5" diagonal
LCD Aspect Ratio	4:3
Display Resolution	320 x 240 RGB
Viewing Angle	60 degrees left, and 60 degrees right, 50 degrees up, and 55 degrees down
Housing Material	Zinc Zamac #3
Bracket Material	Delrin
Stylus	Delrin
Display Weight	4.8 oz
Bracket & Stylus Weight	1.1 oz
Connection	Molex HandyLink connector
Operating Temperature	0 to + 50 °C

P4 BCR

Bar Code Reader



- P4 Bar Code Readers find and decode 2D and 1D linear bar codes.
- Industry-standard bar code metrics and grading
- Economical one-piece solution
- High performance vision inspections in self-contained in-line or right-angle housing styles that fit in the palm of your hand

Conducts high-performance reading of industry standard barcodes.

2D Bar Codes
Data Matrix (ECC200)
QR & Micro QR

1D Bar Codes
Code 128
Code 39
Codabar
Interleaved 2 of 5

EAN-13 (UPC-A)
EAN-8
UPC-E
IMB

Postnet
Pharmacode

Choosing a P4 BCR

Example Model Number P4BCR



Right-Angle Sensor Models
(shown with lens—sold separately)



In-line Sensor Models
(shown with lens—sold separately)

* To add the OCR/OCV premium tool add suffix -OC to the model number. (example P4BCR-OC)

Power and I/O Cable	12-Pin	Video (BNC to BNC)	Ethernet	Shielded	Shielded Crossover	
Hirose with 12 flying leads	P4C06 2 m (6.5') P4C23 7 m (23') P4C32 10 m (32')	P4C50 15 m (49') P4C75 23 m (75') P4C110 34 m (111')	Coaxial with male BNC both ends	BNC06 2 m (6.5') BNC15 5 m (15') BNC30 9 m (30') BNC48 15 m (49')	Straight RJ45 to RJ45 Cable length: 2 m STP07 2 m (6.5') STP25 7 m (25') STP50 9 m (30') STP75 22 m (30')	STPX07 2 m (6.5') STPX25 7 m (25') STPX50 9 m (30') STPX75 22 m (30')

Additional cordset information is available
See page 758

PresencePLUS® P4 Dedicated-Function Specifications

Supply Voltage and Current	10 to 30 V dc (24 V dc \pm 10% if the sensor powers a light source) P4BCR: Less than 650 mA (exclusive of lights and I/O load) P4BCR 1.3: Less than 550 mA (exclusive of lights and I/O load)	
Memory (Storage)	BCR—8 MB Inspection (jobs): 999 max.	BCR 1.3—32 MB Inspection (jobs): 999 max.
Input/Output Configuration	NPN (sinking) or PNP (sourcing) software selectable	
Output Rating	150 mA max. each output OFF-state leakage current: less than 100 μ A ON-state saturation voltage: NPN—less than 1 V @ 150 mA max. PNP—greater than V+ -2 V	
Bicolor Status Indicators	PASS/FAIL: Green ON steady—PASS Red ON steady—FAIL POWER/ERROR: Green ON steady—POWER Red ON steady—ERROR READY/TRIGGER: Green ON steady—READY Yellow ON steady—TRIGGER	
Display Options	PC or NTSC video (uses 9 m max. BNC cordset)	
Discrete I/O	1 Trigger IN 1 Strobe OUT 4 Programmable I/O 1 Product Change IN 1 Remote TEACH IN	
Communications	RJ-45 10/100 Ethernet connection for running PresencePLUS P4 software and/or output inspection results RS-232 connection for output of inspection results	
Imager Resolution	BCR: 640 x 480 pixels	BCR 1.3: 1280 x 1024 pixels
Pixel Size	BCR: 7.4 x 7.4 μ m	BCR 1.3: 6.7 x 6.7 μ m
Imager Size	BCR: 4.8 x 3.6 mm, 6 mm diagonal (1/3 inch CCD)	BCR 1.3: 8.6 x 6.9 mm, 11 mm diagonal (2/3 inch CMOS)
Levels of Gray	256 Gray Scale	
Exposure Time	BCR: 0.1 to 2830 milliseconds	BCR 1.3: 0.1 to 1670 milliseconds
Full Image Acquisition	BCR: 48 frames per second max.*	BCR 1.3: 27 frames per second max.*
Lens Mount	Standard C-mount (1 inch—32 UN)	
Construction	Black anodized aluminum housing, glass lens	
Weight	In-line: 293 g	Right-angle: 385 g
Environmental Rating	IEC IP20; NEMA 1	
Operating Temperature	Stable ambient temperature: 0 to +50 °C Stable ambient lighting: No large, quick changes in light level; no direct or reflected sunlight Relative humidity: 90% (non-condensing)	
Certifications		

* A reduced Field-of-View (FOV) dramatically increases acquisition rates.

Barcode Scanner

Laser Barcode Scanner



- The TCNM can detect over a dozen of the most commonly used linear barcode symbols with a fast reading rate
- Advanced algorithm and multiple scans can reconstruct damaged codes
- Has a barcode reading range of up to 600 mm
- Rugged, IP65-rated industrial housing
- SMART TEACH push button programming



Correct Label Verification
Lot control and traceability for a pharmaceutical manufacturer

Barcode Scanner, 10-30 V DC

Visible Red Laser

Sensing Mode	Range	Resolution	Laser Output	Models
Class 2 laser	40-300 mm	Standard resolution: 8-20 mils	Single line scan	TCNM-AD-1200
	50-310 mm	High performance: 6-20 mils		TCNM-AD-1204
	30-90 mm	High resolution: 6-12 mils		TCNM-AD-2200
	45-100 mm	High resolution, High performance 5-8 mils		TCNM-AD-2204
Class 2 laser	40-300 mm	Standard resolution: 8-20 mils	Ten line raster scan	TCNM-AD-1210
	50-310 mm	High performance: 6-20 mils		TCNM-AD-1214
	30-90 mm	High resolution: 6-12 mils		TCNM-AD-2210
Class 2 laser	45-100 mm	High resolution, High performance 5-8 mils		TCNM-AD-2214
	75-340 mm	Short range: 8-14 mils	Single line scan	TCNM-EX-0200
	100-440 mm	Medium range: 10-20 mils		TCNM-EX-1200
190-600 mm	Long range: 14-20 mils	TCNM-EX-2200		
Class 2 laser	75-340 mm	Short range: 8-14 mils	Ten line raster scan	TCNM-EX-0210
	100-440 mm	Medium range: 10-20 mils		TCNM-EX-1210
	190-600 mm	Long range: 14-20 mils		TCNM-EX-2210

Conducts high-performance reading of industry standard barcodes.

- | | |
|--------------------|----------------------|
| Code 128 | Postnet |
| Code 39 | Pharmacode |
| Codabar | GS1 DataBar |
| Interleaved 2 of 5 | GS1 DataBar Expanded |
| EAN-13 (UPC-A) | GS1 DataBar Limited |
| EAN-8 | |
| UPC-E | |
| IMB | |

Accessories



TCNM-AD-CAB
Serial interface adapter (RS232 or RS-485) going from TCNM-ACBB1 to PC (DB9)



TCNM-ACBB1
Connection box



Barcode Scanner Specifications

Supply Voltage and Current	10 to 30 V dc Maximum 0.5 to 0.17 A; 5 W
Input/Output Configuration	Input 1 (External Trigger), Input 2: Optocoupled, polarity insensitive
Reading Features	Scan Rate (software): (600 to 1000 scans/sec) Aperture Angle: 50°
Construction	Black anodized aluminum housing, glass lens
Weight	330 g
Environmental Rating	IP65
Operating Temperature	Operating temperature: 0 to +45 °C Storage temperature: -20 to +70 °C Relative humidity: 90% (non-condensing)
Hookup Diagrams	See data sheet for more information



Registration, Color & Luminescence

Registration mark sensors reliably detect registration marks in low contrast applications. True color sensors analyze colors and reliably detect registration marks in extremely low contrast applications. These sensors can detect changes in color and intensity of targets of the same color. Luminescence sensors detect luminescent marks even on irregular or reflective backgrounds.

Series	Description	Max Sensing Range	Dimensions H x W x D	Protection Rating	Housing Material	Power Supply
	QC50/QCX50 Accurately analyze and compare colors or varying intensities of color. page 284	Diffuse: 20 mm	50 x 25 x 50 mm	IEC IP62	ABS	10 to 30 V dc
	Q26 Reliably detects luminescent plastics, coatings, lubricants, and other targets on even and uneven surfaces page 286	Diffuse: 30 mm	14 x 25 x 42 mm	IEC IP67	ABS	12 to 30 V dc
	QL56 Detects luminescent marks, even on luminescent backgrounds, and reflective surfaces such as ceramic, metal or mirrored glass. page 288	Diffuse: 50 mm	96.5 x 31.9 x 65.5 mm	IEC IP67	Aluminum	15 to 30 V dc
	R58 Registration mark sensors that detect contrasts as low as 2% over a wide range of colors. page 290	Convergent: 10 mm	62.1 x 30 x 83.3 mm	IEC IP67	Zinc alloy	10 to 30 V dc
	R55 Delivers outstanding color contrast sensitivity and features an innovative TEACH function for setting the sensing threshold. page 294	Varies depending on fiber	85.4 x 30 x 25 mm	IEC IP67; NEMA 6	ABS/polycarbonate blend	10 to 30 V dc

QC50/QCX50 Series

True Color Sensors



- The QC50 and QCX50 accurately analyze and compare colors or varying intensities of color. The QC50 will solve most color comparison applications and for challenging applications such as reading the difference between dark blue and black use the QCX50.
- Offers easy-to-set push-button programming options for up to three colors
- Compact, self-contained design
- Offers fast response time of 335 microseconds, depending on model

QC50, 10-30 V DC

Visible White LED

Sensing Mode	Range	Connection	Response Time	Output Type	Models
 DIFFUSE	20 mm typical; varies according to sensor configuration	8-pin Euro QD	335 μ s	NPN, 3 channels	QC50A3N6XDWQ
				PNP, 3 channels	QC50A3P6XDWQ

QCX50, 10-30 V DC

Visible White LED

Sensing Mode	Range	Connection	Response Time	Output Type	Models
 DIFFUSE	20 mm typical; varies according to sensor configuration	8-pin Euro QD	Selectable 5 ms or 1 ms	NPN, 3 channels	QCX50A3N6XDWQ
				PNP, 3 channels	QCX50A3P6XDWQ

Connection options: A model with a QD requires a mating cordset.



Euro-Style

Straight connector models listed; for right-angle, add **RA** to the end of the model number (example, **MQDC2S-806RA**)

- MQDC2S-806**
2 m (6.5')
- MQDC2S-815**
5 m (15')
- MQDC2S-830**
9 m (30')



SMBQC50

Additional bracket information is available
See page 725

Additional cordset information is available
See page 758



QC50/QCX50 Specifications

Sensing Receiver	Solid-state photodiode device with R, G, B filters
Minimum Spot Diameter	4 mm
Supply Voltage and Current	10 to 30 V dc, 2 V pp max ripple 40 mA max @ 24 V dc (excluding output current)
Supply Protection Circuitry	Protected against reverse polarity, over-voltage, and transient voltage
Output Configuration	3 PNP or 3 NPN outputs, depending on model 30 V dc max. Saturation voltage: less than 2 V
Output Rating	100 mA max. load per output channel
Output Protection Circuitry	Protected against output short-circuit, continuous overload, transient over-voltages, and false pulse on power-up
Output Response Time	QC50 models: 335 microseconds QCX50 models: Selectable 5 milliseconds (normal) or 1 millisecond QC50 models QCX50 models Gate ON-time: 335 microseconds 700 microseconds Gate OFF-time: 170 microseconds 400 microseconds
Delay at Power-up	500 milliseconds; outputs do not conduct during this time
Data Retention	EEPROM nonvolatile memory
Ambient Light Rejection	According to EN 609475-2
Adjustments	2 push buttons (Set and Select) • Color, scanning, color modes, delay and tolerance • Manual adjustment of color channels, sensing mode and tolerance level
Indicators	4-Digit LCD Display: indicates sensing mode, run status, tolerance level, output status Yellow Output LED: ON when any output is conducting 3 Green Channel Output Status LEDs: ON when its corresponding output is conducting
Construction	ABS shock-resistant housing; glass window and lens
Environmental Rating	IEC IP67
Operating Conditions	Temperature: -10 to +55 °C Relative humidity: 90% at 50 °C (non-condensing)
Shock Resistance	Approx. 30 G; 3 shocks per axis; 11 milliseconds duration
Vibration	0.5 mm amplitude; 10 to 60 Hz frequency; 30 minutes for each X, Y, Z axis

Certifications



Q26 Series

Luminescence Sensor



- Reliably detects luminescent plastics, coatings, lubricants, and other targets on even and uneven surfaces
- Simple configuration with the push button on the sensor's housing or via a remote input line
- Rotary switch selects Light Operate or Dark Operate
- IP67-rated housing for use in rugged industrial environments
- Compact housing size

Q26, 12-30 V DC

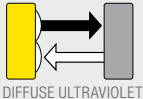
Sensing Mode	Range	Connection	Models NPN	Models PNP
 DIFFUSE ULTRAVIOLET	10 to 30 mm	4-pin M12/Euro-style quick disconnect fitting on a 150 mm (6 in) PVC cable jacket	Q26NLUMQ5	Q26PLUMQ5

 Connection options: A model with a QD requires a mating cordset.

For a 9 m cable, add suffix W/30 to the 2 m model number (example, Q26NXLQP7 W/30)



Euro-Style Cordsets
 Straight connector models listed;
 for right-angle, add **RA** to the end
 of the model number (example,
MQDC-406RA)

4-Pin
MQDC-406
 2 m (6.5')
MQDC-415
 5 m (15')
MQDC-430
 9 m (30')

*Additional cordset information is available
 See page 758*



SMBLSTDLQ26





SMBLSTQ26

*Additional bracket information is available
 See page 725*



Q26 Specifications

Supply Voltage and Current	12 to 30 V dc (2 Vpp maximum ripple) Supply current (exclusive of load current): 30 mA
Supply Protection Circuitry	Protected against reverse polarity and transient voltages
Output Configuration	NPN or PNP
Output Rating	100 mA max (exclusive of load) ON-state saturation voltage: less than 2 V @ 10 mA dc; less than 1.5 V @ 150 mA dc
Output Protection Circuitry	Protected against false power-up and continuous overload or short circuit of outputs
Output Response Time	250 μS or 1 ms (based on sensitivity)
Indicators	Green ON: Power ON Amber ON: Output conducting
Construction	ABS plastic housing, glass window, polycarbonate lens
Operating Conditions	Temperature: -10 to +55 °C Relative Humidity: 90% at 50°; non-condensing
Environmental Rating	IEC IP67
Vibration and Shock	EN60068-2-6 and EN60068-2-27
Certifications	 

QL56 Series

Luminescence Sensors



- The Q25 sensor is completely epoxy-encapsulated for use in harsh sensing environments, including food and beverage applications.
- Compact, self-contained design
- Includes easy-to-set programming options
- High-speed response of 250 microseconds

QL56, 15-30 V DC

➔ Black Ultraviolet LED

⇨ Returned Luminescence

Sensing Mode	Range	Connection	Output Type	Models
DIFFUSE	10-20 mm	5-pin Euro QD	Bipolar NPN/PNP plus one 0.75-5.5 V dc analog	QL56M6XD15BQ
DIFFUSE	20-40 mm	5-pin Euro QD	Bipolar NPN/PNP plus one 0.75-5.5 V dc analog	QL56M6XD30BQ
DIFFUSE	30-50 mm	5-pin Euro QD	Bipolar NPN/PNP plus one 0.75-5.5 V dc analog	QL56M6XD40BQ

Connection options: A model with a QD requires a mating cordset.



QL56M6XD30BQ Models



QL56M6XD15BQ Models



QL56M6XD40BQ Models



5-Pin

Euro-Style

Straight connector models listed; for right-angle, add **RA** to the end of the model number (example, **MQDC1-506RA**)

MQDC1-506

2 m (6.5')

MQDC1-515

5 m (15')

MQDC1-530

9 m (30')



SMB55A



SMB55RA



SMB55F



SMB55S

Additional cordset information is available
See page 758

Additional bracket information is available
See page 725

QL56 Specifications

Sensing Beam	LED UV, 375 nm; class 1
Supply Voltage and Current	15 to 30 V dc, (2 V pp max ripple); 50 mA max @ 24 V dc (excluding output current)
Supply Protection Circuitry	Protected against reverse polarity
Output Configuration	Bipolar (1 NPN & 1 PNP), plus 0.75 to 5.5 V dc analog output
Analog Output	0.75 to 5.5 V dc max
Analog Output Impedance	2.2 k Ω (short-circuit protection)
Output Rating	100 mA max.
Output Saturation Voltage	< 2 V
Output Protection Circuitry	Overload and short circuit protection
Output Response Time	250 microseconds
Ambient Light Rejection	According to EN 60947-5-2
Adjustments	"+" and "-" push buttons determine sensitivity "Set" push button activates delay and keylock function
Switching Frequency	2 kHz
Delay at Power-up	0 milliseconds (default) or 20 milliseconds user selectable
Indicators	Green Ready LED: ON indicates power on; Flashing indicates output overload Yellow Output LED: ON indicates output conducting Orange Delay LED: ON indicates 20 milliseconds delay activated Orange Keylock LED: ON indicates push buttons are unlocked 5-segment bar graph: Indicates sensitivity
Construction	Aluminum housing, glass lens; mass 180 g. max.
Environmental Rating	IP67
Operating Conditions	Temperature: -10 to +55 °C Storage Temperature: -20 to 70 °C
Minimum Spot Dimensions	2 x 8 mm @ 10 mm (QL56M6XD15BQ) 3 x 11 mm @ 24 mm (QL56M6XD30BQ) 4 x 15 mm @ 50 mm (QL56M6XD40BQ)
Shock Resistance	30 G; 6 shocks per axis; 11 milliseconds duration (EN60068-2-27)
Vibration	0.5 mm amplitude; 10 to 55 Hz frequency; per axis (EN60068-2-6)
Application Notes	The lens must be used in the lower position, and the cap must remain in place on the end position
Certifications	

R58 Expert™ Series



Registration Mark Sensors

- The R58E sensors offer maintenance-free, solid-state reliability for color contrast applications. With a fast, 50-microsecond sensing response time, the R58E provides excellent registration repeatability, even in speedy applications.
- Bipolar outputs
- 10,000 actuations per second and 15 microsecond repeatability
- Rugged mechanical housing rated to IP67

R58 Expert™, 10-30 V DC

 Visible Red, Green or Blue LED, depending on registration mark

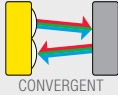
Sensing Mode/LED	Focus	Connection	Output Type	Models	
				Parallel	Perpendicular
 <p>CONVERGENT</p>	10 mm	2 m	Bipolar NPN/PNP	R58ECRGB1	R58ECRGB2
		5-pin Euro Pigtail QD	Bipolar NPN/PNP	R58ECRGB1Q	R58ECRGB2Q
		2 m	PNP	R58BPCRGB1	R58BPCRGB2
		5-pin Euro Pigtail QD	PNP	R58BPCRGB1Q	R58BPCRGB2Q
		2 m	NPN	R58BNCRGB1	R58BNCRGB2
		5-pin Euro Pigtail QD	NPN	R58BNCRGB1Q	R58BNCRGB2Q

For more specifications see page 293.

 Connection options: A model with a QD requires a mating cordset (see page 292)

For 9 m cable, add suffix W/30 to the 2 m model number (example, R58ECRGB1 W/30).

QD models: For integral 5-pin Euro-style QD, add suffix Q8 to the 2 m model number (example R58ECRGB1Q8).

R58A Series

Registration Mark Sensors



- Easy to set multi-turn potentiometer
- The R58A provides outstanding color contrast sensitivity in low-contrast or high-gloss applications and detects contrasts as low as 2% over a wide range of colors
- Bipolar outputs
- Provides a single emitter color of red or green, depending on model
- Rugged mechanical housing rated to IP67

R58A Expert™, 10-30 V DC

➔ Visible Red LED ➔ Visible Green LED

Sensing Mode/LED	Focus	Connection	Output Type	OFF-Delay	Models	
					Parallel	Perpendicular
 CONVERGENT	10 mm	2 m	Bipolar NPN/ PNP	0 ms	R58ACG1	R58ACG2
		4-pin Euro Pigtail QD			R58ACG1Q	R58ACG2Q
		2 m			R58ACG1D	R58ACG2D
		4-pin Euro Pigtail QD			R58ACG1DQ	R58ACG2DQ
 CONVERGENT	10 mm	2 m	Bipolar NPN/ PNP	0 ms	R58ACR1	R58ACR2
		4-pin Euro Pigtail QD			R58ACR1Q	R58ACR2Q
		2 m			R58ACR1D	R58ACR2D
		4-pin Euro Pigtail QD			R58ACR1DQ	R58ACR2DQ

For more specifications see page 293.

➔ Connection options: A model with a QD requires a mating cordset (see page 292)

For 9 m cable, add suffix W/30 to the 2 m model number (example, R58ACG1 W/30).

QD models: For integral 4-pin Euro-style QD, add suffix Q8 to the 2 m model number (example, R58ACG1Q8).



Euro-Style
Straight connector models listed;
for right-angle, add **RA** to the end
of the model number (example,
MQDEC2-506RA)

Used with: Expert models

MQDEC2-506
2 m (6.5')
MQDEC2-515
5 m (15')
MQDEC2-530
9 m (30')



4-Pin

Euro-Style Cordsets
Straight connector models listed;
for right-angle, add **RA** to the end
of the model number (example,
MQDC-406RA)

Used with: R58A models

MQDC-406
2 m (6.5')
MQDC-415
5 m (15')
MQDC-430
9 m (30')

Additional cordset information is available
See page 758



SMB55A



SMB55RA



SMB55F



SMB55S

Additional bracket information is available
See page 725



R58 Expert



R58B



R58A

R58 Specifications

Supply Voltage and Current	10 to 30 V dc (10% max. ripple) R58A: 36 mA exclusive of load R58B & R58E: 75 mA @ 10 V dc 35 mA @ 30 V dc
Supply Protection Circuitry	Protected against reverse polarity and transient voltages
Output Configuration	R58 Expert & R58A: Bipolar: One current sourcing (PNP) and one current sinking (NPN) R58B: Single output: One current sourcing (PNP) or one current sinking (NPN)
Output Rating	R58 Expert & R58B: 100 mA max. (each output) OFF-state leakage current: NPN less than 200 μ A; PNP less than 10 μ A NPN saturation: less than 1.6 V @ 100 mA PNP saturation: less than 3 V @ 100 mA R58A: 150 mA max. (each output) OFF-state leakage current: less than 10 μ A NPN saturation: less than 200 mV @ 10 mA and less than 1 V @ 150 mA PNP saturation: less than 1 V @ 10 mA and less than 2 V @ 150 mA
Output Protection Circuitry	Protected against false pulse on power-up and continuous overload or short-circuit of outputs
Output Response Time	50 microseconds
Delay at Power-up	R58A: 100 milliseconds; outputs do not conduct during this time R58B & R58E: 1 second; outputs do not conduct during this time
Repeatability	15 microseconds
Sensing Image	Rectangular: 1.2 x 3.8 mm at 10 mm from face of lens; image oriented either parallel or perpendicular to sensor length, depending on model
Adjustments	R58 Expert & R58B: 2 push buttons and remote wire for sensor TEACH programming and configuration. See datasheet for detailed information. R58A: Light/Dark Operate (LO/DO) select switch, and 15-turn switchpoint adjustment potentiometer
Indicators	R58 Expert: 8-segment Bargraph display: Green: Power ON Yellow: Outputs ON 2-position Green: LED ON next to DO for Dark Operate LED ON next to LO for Light Operate 2-position Green: LED ON next to ON for ON-delay LED ON next to OFF for OFF-delay R58B: Green: Power ON Amber: Output active R58A: Amber: Output active Green: Switchpoint threshold adjustment indicators See datasheet for detailed information.
Construction	Zinc alloy die-cast housing with black painted finish and o-ring sealed lens port cap Lens: Acrylic Lens port cap and lens holder: ABS Sensitivity and LO/DO adjusters: Acetal QD: Anodized aluminum
Environmental Rating	IEC IP67
Operating Conditions	Temperature: R58E: -10 to +50 °C R58A & R58B: -10 to +55 °C Relative humidity: 90% at 50 °C (non-condensing) Storage temperature: -20 to +80 °C
Shock and Vibration	All models meet IEC 68-2-6 and IEC 68-2-27 testing criteria
Certification	

R55F Series

Fiber Optic Sensors



- Reliably detects 16 levels of grayscale at up to 10,000 actuations per second
- 10,000 actuations per second and 15 microsecond repeatability
- Bipolar outputs

R55F Fiber Optic, 10-30 V DC

→ Visible Green LED
 → Visible Blue LED
 ⇔ Visible White LED
 ⇔ Infrared LED
 → Visible Red LED

Sensing Mode	Range	Connection	Output Type	Models
 GLASS FIBER	Range varies by sensing mode and fiber optics used	2 m	Bipolar NPN/PNP	R55F
		5-pin Euro QD		R55FQ
 GLASS FIBER	Range varies by sensing mode and fiber optics used	2 m	Bipolar NPN/PNP	R55FV
		5-pin Euro QD		R55FVQ
 GLASS FIBER	Range varies by sensing mode and fiber optics used	2 m	Bipolar NPN/PNP	R55FVG
		5-pin Euro QD		R55FVGQ
 GLASS FIBER	Range varies by sensing mode and fiber optics used	2 m	Bipolar NPN/PNP	R55FVB
		5-pin Euro QD		R55FVBQ
 GLASS FIBER	Range varies by sensing mode and fiber optics used	2 m	Bipolar NPN/PNP	R55FVW
		5-pin Euro QD		R55FVWQ
 PLASTIC FIBER	Range varies by sensing mode and fiber optics used	2 m	Bipolar NPN/PNP	R55FP
		5-pin Euro QD		R55FPQ
 PLASTIC FIBER	Range varies by sensing mode and fiber optics used	2 m	Bipolar NPN/PNP	R55FPG
		5-pin Euro QD		R55FPGQ
 PLASTIC FIBER	Range varies by sensing mode and fiber optics used	2 m	Bipolar NPN/PNP	R55FPB
		5-pin Euro QD		R55FPBQ
 PLASTIC FIBER	Range varies by sensing mode and fiber optics used	2 m	Bipolar NPN/PNP	R55FPW
		5-pin Euro QD		R55FPWQ







 Connection options: A model with a QD requires a mating cordset.

For 9 m cable, add suffix W/30 to the 2 m model number (example, R55F W/30).



Stainless Steel

Stainless steel sensors hold up well in extremely abusive environments and can handle a wide variety of chemicals. This makes them ideal for hygienic applications, such as food and beverage applications.

Series	Description	Max Sensing Range	Dimensions H x W x D	Protection Rating	Power Supply
	QM26 The QM26 withstands high-pressure washdown environments and is easy to mount for a hassle-free setup. Page 298	Opposed: 8.5 m Polar Retro: 3 m Coaxial Polar Retro: 2.6 m Background Suppression: 200 mm	48.5 x 14 x 25 mm	IP69K	10-30 V dc
	QMH26 The QMH26 is designed with minimal grooves and crevices, making it easy to clean and ideal for clean-in-place (CIP) applications. Page 300	Polar Retro: 3 m Coaxial Polar Retro: 2.6 m Background Suppression: 400 mm Foreground Suppression: 200 mm	53.7 x 14 x 20.3 mm	IP69K	10-30 V dc
	M25U Universal housing design with 18 mm threaded lens; an ideal replacement for hundreds of other sensor styles. Available in eight modes with a compact housing for limited space setups. Page 302	Ultrasonic: 500 mm	103 x ø 25 mm	IP67; NEMA 6, IP69K	10-30 V dc
	SM30 Powerful sensor with a long range and the stainless steel model can be used in abusive environments. Page 304	Opposed: 150 m	30 ø x 102 mm	IEC IP67; NEMA 6	10-30 V dc, 2-240 V ac
	VSM Series Heavy-duty metal sensors that are compact and ideal for use in confined areas. Page 306	Opposed: 250 mm Diffuse: 200 mm	Varies by model	IP67; NEMA 6P	10-30 V dc
	M18-4 Heavy-duty barrel sensor protected by a 316 stainless steel housing that resists exposure to harsh chemicals and washdown conditions. Page 308	Opposed: 25 m Retro: 7.5 m Polarized Retro: 6 m Diffuse: 750 mm Fixed-Field: 200 mm	18 ø x 63.5 mm	IP67 IP68 IP69K	10-30 V dc

OTHER AVAILABLE MODELS



Q4X page 34

QM26 Series

Washdown Sensors



- The QM26 withstands high-pressure washdown environments and is easy to mount for a hassle-free setup
- Rugged, chemically resistant and food safe 316L stainless steel housing
- Reliably detects clear materials in harsh environments
- IP69K rated for use in harsh 1500 psi and 80 °C washdown
- Withstands environmental temperature cycling from -30 to 60 °C

Opposed QM26

Sensing Mode	Range	Connection	Models NPN	Models PNP
 OPPOSED	8.5 m	4-pin Euro QD	QM26EQ5 Emitter	
			QM26VNRQ5	QM26VPRQ5

Polar Retro QM26

Sensing Mode	Range	Connection	Models NPN	Models PNP
 POLAR RETRO	3 m	4-pin Euro QD	QM26VNLPCQ5	QM26VPLPCQ5

Coaxial Polar Retro QM26

Sensing Mode	Range	Connection	Models NPN	Models PNP
 COAXIAL POLAR RETRO	2.6 m	4-pin Euro QD	QM26ENXLPQ5	QM26EPXLPQ5

Background Suppression QM26

Sensing Mode	Range	Connection	Models NPN	Models PNP
 BACKGROUND SUPPRESSION	5-400 mm Cutoff	4-pin Euro QD	QM26VNAF400Q5	QM26VPAF400Q5
	5-200 mm Cutoff (small light spot)	4-pin Euro QD	QM26VNAF200Q5	QM26VPAF200Q5

Connection options: A model with a QD requires a mating cordset.

For a 5 m cable, replace Q5 with -5M to the 2 m model number (example, QM26E-5M)



Euro-Style
Straight connector models listed; for right-angle, add **RA** to the end of the model number (example, **MQDC-406RA**)

4-Pin	5-Pin
MQDC-406 2 m (6.5')	MQDC1-506 2 m (6.5')
MQDC-415 5 m (15')	MQDC1-515 5 m (15')
MQDC-430 9 m (30')	MQDC1-530 9 m (30')

Additional cordset information is available
See page 758



SMBLSTDQ26



SMBLSTQ26

Additional bracket information is available
See page 725

Reflectors



Additional information is available
See page 790

Apertures



Additional information is available
See page 816



QM26 Specifications

Supply Voltage and Current	10 to 30 V dc (10% maximum ripple within specified limits); supply current (exclusive of load current) less than 20mA
Supply Protection Circuitry	Protected against reverse polarity and transient voltages
Output Configuration	Most Models: Complementary PNP or NPN by model number
Output Rating	100 mA max OFF-state leakage current for load: NPN less than 200 µA; PNP less than 500 µA ON-state saturation voltage: less than 2 V @ 100 mA
Output Protection Circuitry	Protected against false pulse at power-up and continuous overload or short circuit of outputs
Output Response Time	500 microseconds ON and OFF
Repeatability	Opposed mode: 110 microseconds All other mode: 150 microseconds
Indicators	Green steady: Power ON Yellow steady: Light sensed Yellow flashing: Light sensed but marginal signal
Construction	316L stainless steel housing; acrylic window
Operating Conditions	Temperature: -30 to +70 °C Relative Humidity: Periodic exposure to 100% humidity and washdown cleaning
Environmental Rating	IP67 & IP69K, Ecolab® compatible
Vibration and Shock	IEC60947-5-2

Certifications



With Class 2 power

ECOLAB® chemical compatibility pending on some models; contact Banner Engineering for details

QMH26 Series

Hygienic Sensors



- The QMH26 is designed with minimal grooves and crevices, making it easy to clean and ideal for clean-in-place (CIP) applications
- Rugged, chemically resistant and food safe 316L stainless steel housing
- Reliably detects clear materials in harsh environments
- IP69K rated for use in harsh 1500 psi and 80° C washdown
- High chemical resistance for the most demanding photoelectric sensing environments

Polar Retro QMH26

Sensing Mode	Range	Connection	Models NPN	Models PNP
 POLAR RETRO	3 m	4-pin Pico QD	QMH26VNLPQ7	QMH26VPLPQ7

Coaxial Polar Retro QMH26

Sensing Mode	Range	Connection	Models NPN	Models PNP
 COAXIAL POLAR RETRO	2.6 m	4-pin Pico QD	QMH26ENXLPQ7	QMH26EPXLPQ7

Background Suppression QMH26

Sensing Mode	Range	Connection	Models NPN	Models PNP
 BACKGROUND SUPPRESSION	Adjustable between 5-400 mm	4-pin Pico QD	QMH26VNAF400Q7	QMH26VPAF400Q7

Foreground Suppression QMH26

Sensing Mode	Range	Connection	Models NPN	Models PNP
 FOREGROUND SUPPRESSION	Adjustable between 5-200 mm	4-pin Pico QD	QMH26VNAF200Q7	QMH26VPAF200Q7

Connection options: A model with a QD requires a mating cordset.

For a 5 m cable, replace Q7 with -5M in the model number (example, QMH26VNLP-5M)



Pico QD (for Q models)
Straight connector models listed; for right-angle, **W** replaces **G** in the model number.
(example, **PKW3M-2**)

4-Pin
PKG4M-2
2 m (6')
PKG4M-5
5 m (15')
PKG4M-9
9 m (30')

Additional cordset information is available
See page 758



SMBLSTDLQ26



SMBLSTQ26



SMBQMH26-SS-150

Additional bracket information is available
See page 725

Reflectors



Additional information is available
See page 790

Apertures



Additional information is available
See page 816

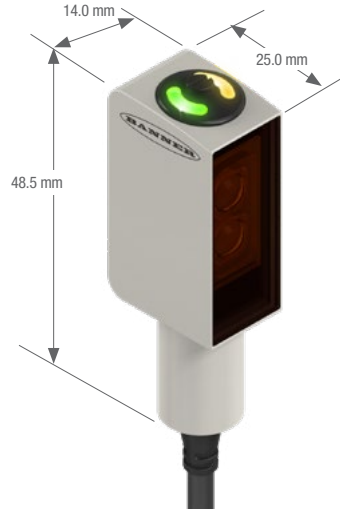

QMH26 Specifications

Supply Voltage and Current	10 to 30 V dc (10% maximum ripple within specified limits); supply current (exclusive of load current) less than 20mA
Supply Protection Circuitry	Protected against reverse polarity and transient voltages
Output Configuration	Most Models: Complementary PNP or NPN by model number QMH26E...XLPC models: Single PNP or NPN on pin 4 (black wire) with remote teach input on pin 2 (white wire)
Output Rating	100 mA max OFF-state leakage current for load: NPN less than 200 μ A; PNP less than 500 μ A ON-state saturation voltage: less than 2 V @ 100 mA
Output Protection Circuitry	Protected against false pulse at power-up and continuous overload or short circuit of outputs
Output Response Time	500 microseconds ON and OFF
Repeatability	Opposed mode: 110 microseconds All other mode: 150 microseconds
Indicators	Green steady: Power ON Yellow steady: Light sensed Yellow flashing: Light sense but marginal signal
Construction	316L stainless steel housing; acrylic window
Operating Conditions	Temperature: -30 to +70 °C Relative Humidity: Periodic exposure to 100% humidity and washdown cleaning
Environmental Rating	IP67 & IP69K, ECOLAB® compatible
Vibration and Shock	IEC60947-5-2

Certifications



With Class 2 power ECOLAB® chemical compatibility pending on some models; contact Banner Engineering for details

M25U



Stainless Steel Ultrasonic Sensors

- Cleans easily with no thread, gaps or seams to trap debris
- The M25U Ultrasonic Sensor features a smooth 316 series stainless steel construction to withstand the toughest sanitary challenges
- Constructed with FDA approved materials and rated to IP69K, IEC IP67 (NEMA 6) with fully encapsulated electronics

M25U

Range*	Frequency	Connection	Output	Response Time	Models
Normal Speed:500 mm High Speed:250 mm	140 kHz	4-pin Euro QD	—	—	M25UEQ8 Emitter
Normal Speed:500 mm High Speed:250 mm	140 kHz	5-pin Euro QD	Bipolar NPN/PNP	Normal Speed: 4.0 ms High Speed: 3.0 ms	M25URBQ8 Receiver

 Connection options: A model with a QD requires a mating cordset

* M25U receivers may be wired for either of two speed modes: Normal or High, depending on hookup. The Normal-Speed mode offers a sensing range of 500 mm. The Normal-Speed mode maximizes sensing energy, as is required in demanding environments. The High-Speed mode offers a sensing range of 250 mm. The High-Speed mode maximizes sensing response, as is needed in high-speed counting applications.



Euro-Style with Shield
Straight connector models listed; for right-angle, add **RA** to the end of the model number (example, **MQDEC2-506RA**)

5-Pin
MQDEC2-506
2 m (6.5')
MQDEC2-515
5 m (15')
MQDEC2-530
9 m (30')



Washdown **Euro-Style**
Straight connector models listed

5-Pin
MQDCWD-506
2 m (6.5')
MQDCWD-530
9 m (30')

Additional cordset information is available
See page 758



SMBM25A



SMBM25B

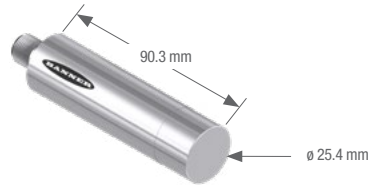

Additional bracket information is available
See page 725

M25U Specifications

Sensing Range	Normal Speed: 500 mm High Speed: 250 mm 140KHz
Supply Voltage and Current	Emitter: 10 to 30 V dc (10% max. ripple) at less than 85 mA Receiver: 10 to 30 V dc (10% max. ripple) at less than 38 mA (exclusive of load)
Supply Protection Circuitry	Protected against reverse polarity and transient voltages
Receiver Output Configuration	Bipolar (1 NPN & 1 PNP) solid-state output; Normally Open (output is activated when an object blocks the sensing beam)
Output Rating	100 mA (each output) with short circuit protection; see Note 1 OFF-state leakage current: NPN: < 200 µA sinking ON-state saturation voltage: NPN: < 1.6 V @ 100 mA PNP: < 10 µA sourcing PNP: < 3.0 V @ 100 mA
Output Protection Circuitry	Protected against short circuit conditions
Output Response Time	Normal Speed: 4.0 milliseconds High Speed: 3.0 milliseconds
Repeatability	1 millisecond
Delay at Power-up	< 250 milliseconds
Delay for Switching Between Normal and High Speed	20 milliseconds
Indicators	Green Power LED: indicates Power ON Amber Output LED: indicates output activated
Construction	Housing: 316 Stainless Steel LED window: Polysulfone
Environmental Rating	Leakproof design, rated IEC IP67 (NEMA 6), IP69K
Operating Conditions	Temperature: -20 to +70 °C Max. Relative Humidity: 95% at 50 °C non-condensing
Vibration and Mechanical Shock	All models meet Mil. Std. 202F requirements method 201A (vibration: 10 to 60 Hz max. amplitude 0.06", max. acceleration 10G). Also meets IEC 947-5-2; 30G 11 ms duration.
Certifications	CE

Notes

1. NPN < 200 µA for load impedance > 3 KΩ; for load current of 100 mA, leakage < 1% of load current
2. When mounting the M25U, care should be taken to acoustically isolate the emitter and receiver to eliminate sound energy coupling between the sensor pair. This is best accomplished with elastomeric materials between the sensor and rigid mounting brackets.

SM30

High-Power, Long-Range, Opposed-Mode
Barrel Sensors

- The SM30 is a powerful sensor with a long range for different frequencies and the stainless steel model can be used in abusive environments
- Available with ac or dc supply voltages
- Ideal in equipment washdown environments

SM30 Emitters, 10-30 V DC or 12-240 V AC, Frequency A[†]

Infrared LED

Sensing Mode	Housing	Range	Connection	Output Type	Models
	Plastic	150 m	2 m 3-Pin Mini QD	N/A	SMA30PEL SMA30PELQD
	Stainless Steel	150 m	2 m 3-Pin Mini QD	N/A	SMA30SEL SMA30SELQD

SM30 Receivers, 10-30 V DC Frequency A[†]

Infrared LED

Sensing Mode	Housing	Range	Connection	Output Type	Models
	Plastic	150 m	2 m 4-Pin Mini QD	Bi-Modal™ NPN or PNP	SM30PRL SM30PRLQD
	Stainless Steel	150 m	2 m 4-Pin Mini QD	Bi-Modal™ NPN or PNP	SM30SRL SM30SRLQD

SM30 Receivers, 24-240 V AC, Frequency A[†]

Infrared LED

Sensing Mode	Housing	Range	Connection	Output Type	Models
	Plastic	150 m	2 m	LO	SM2A30PRL
			3-Pin Mini QD		SM2A30PRLQD
	Stainless Steel	150 m	2 m	LO	SM2A30SRL
			3-Pin Mini QD		SM2A30SRLQD
	Plastic	150 m	2 m	DO	SM2A30PRLNC
3-Pin Mini QD			SM2A30PRLNCQD		
Stainless Steel	150 m	2 m	DO	SM2A30SRLNC	
			3-Pin Mini QD		SM2A30SRLNCQD

Connection options: A model with a QD requires a mating cordset.

For 9 m cable, add suffix W/30 to the 2 m model number (example, SM30PR W/30).

[†] Modulation frequency "A" is standard; frequencies "B" and "C" are also available to minimize optical crosstalk potential between adjacent pairs and are specified by adding "B" or "C" at the end of the standard model number (example, SM30PRLB or SM30PRLC).

Mini QD
Straight connector
models listed



	3-Pin	4-Pin
	SM30CC-306	MBCC-406
	2 m (6.5')	2 m (6.5')
	SM30CC-312	MBCC-412
	3 m (12')	3 m (12')

Additional cordset information is available
See page 758



SMB30A



SMB30FA..

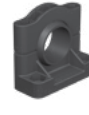

SMB30SC



SMBAMS30P

Additional bracket information is available
See page 724

Apertures



Additional information is available
See page 816



Opposed Models—All Frequencies
Suffix E and R

SM30 Specifications

Supply Voltage and Current	<p>Emitters: 12 to 240 V ac (50/60 Hz) or 10 to 30 V dc (10% max. ripple) at 20 mA</p> <p>DC Receivers: 10 to 30 V dc (10% max. ripple) at 10 mA max, exclusive of load</p> <p>AC Receivers: 24 to 240 V ac (50/60 Hz)</p>
Supply Protection Circuitry	Protected against reverse polarity and transient voltages
Output Configuration	<p>DC Receivers: Bi-Modal™ output (PNP sourcing or NPN sinking). Selection of sourcing or sinking configuration depends upon receiver's power supply hookup polarity. Once wired, the unit performs as a solid-state switch.</p> <p>AC Receivers: Solid-state switch offer Light Operate (LO) or Dark Operate (DO) by model</p>
Output Rating	<p>DC Receivers: 250 mA continuous</p> <p>Output saturation voltage: (PNP & NPN configuration) less than 1 volt at 10 mA; less than 2 volts at 250 mA</p> <p>OFF-state leakage current: less than 10 μA</p> <p>AC Receivers: Max. steady-state load capability is 500 mA</p> <p>Inrush capability: 10 amps for 1 second (non-repeating)</p> <p>OFF-state leakage: current less than 1.7 mA rms</p> <p>ON-state voltage drop: less than 3.5 volts rms across a 500 mA load; less than 5 volts rms across a 15 mA load</p>
Output Protection Circuitry	Outputs of dc receivers are short circuit protected
Output Response Time	10 milliseconds ON/OFF
Repeatability	<p>"A" frequency units: 1 millisecond</p> <p>"B" frequency units: 1.5 milliseconds</p> <p>"C" frequency units: 2.3 milliseconds</p>
Indicators	<p>Internal Red LED, visible through the lens or from side of the sensor.</p> <p>Emitters: Red "Power ON" indicator LED</p> <p>DC Receivers: Lights whenever receiver sees its modulated light source</p> <p>AC Receivers: Lights whenever receiver's output is conducting</p>
Construction	Fully epoxy-encapsulated tubular threaded housing, positive sealed at both ends, quad-ring sealed acrylic lens 30 mm diameter 303 stainless steel housing and jam nuts
Environmental Rating	Exceeds NEMA 6P; IEC IP67 standards
Operating Conditions	Temperature: -40 to +70 °C Relative humidity: 90% at 50 °C (non-condensing)

Certifications



VSM Series

Self-Contained Metal Sensors



- Heavy-duty, compact, metal sensors that are ideal for use in confined areas.
- Sapphire lens
- Tough 300 series stainless steel body withstands a wide variety of chemicals and cutting fluids
- Smooth barrel models are ideal for hygienic applications that require frequent cleaning
- Advanced optical design provides high performance with repeatable sensing

VSMQ (Flat-Pack, Side-Looker)

Infrared LED

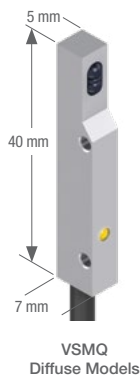

Sensing Mode	Range	Connection	Output Type	Models NPN	Models PNP
DIFFUSE	20-50 mm	2 m	LO	VSMQAN6CV20	VSMQAP6CV20
DIFFUSE	50-140 mm	2 m	LO	VSMQAN6CV50	VSMQAP6CV50
DIFFUSE	90-200 mm	2 m	LO	VSMQAN6CV90	VSMQAP6CV90

VSM4 (4 mm Smooth Barrel)

Infrared LED

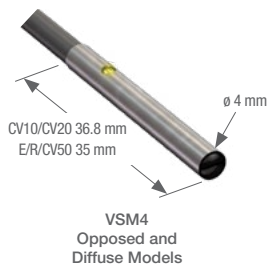

Sensing Mode	Range	Connection	Output Type	Models NPN	Models PNP
OPPOSED	250 mm	2 m	—	VSM46E Emitter	
	250 mm	3-Pin Pico QD	—	VSM46EQ7 Emitter	
OPPOSED	250 mm	2 m	DO	VSM4RN6R	VSM4RP6R
	250 mm	3-Pin Pico QD		VSM4RN6RQ7	VSM4RP6RQ7
DIFFUSE	10-30 mm	2 m	LO	VSM4AN6CV10	VSM4AP6CV10
	10-30 mm	3-Pin Pico QD		VSM4AN6CV10Q7	VSM4AP6CV10Q7
DIFFUSE	20-50 mm	2 m	LO	VSM4AN6CV20	VSM4AP6CV20
		3-Pin Pico QD		VSM4AN6CV20Q7	VSM4AP6CV20Q7
DIFFUSE	50-140 mm	2 m	LO	VSM4AN6CV50	VSM4AP6CV50
		3-Pin Pico QD		VSM4AN6CV50Q7	VSM4AP6CV50Q7

Connection options: A model with a QD requires a mating cordset.

VSM5 (5 mm Threaded Barrel)

 Infrared LED

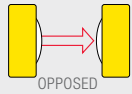
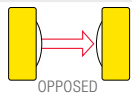
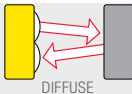
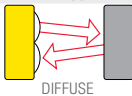
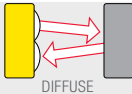
Sensing Mode	Range	Connection	Output Type	Models NPN	Models PNP
 OPPOSED	250 mm	2 m 3-Pin Pico QD	—	VSM56E Emitter VSM56EQ7 Emitter	
 OPPOSED	250 mm	2 m 3-Pin Pico QD	DO	VSM5RN6R VSM5RN6RQ7	VSM5RP6R VSM5RP6RQ7
 DIFFUSE	10-30 mm	2 m 3-Pin Pico QD	LO	VSM5AN6CV10 VSM5AN6CV10Q7	VSM5AP6CV10 VSM5AP6CV10Q7
 DIFFUSE	20-50 mm	2 m 3-Pin Pico QD	LO	VSM5AN6CV20 VSM5AN6CV20Q7	VSM5AP6CV20 VSM5AP6CV20Q7
 DIFFUSE	50-140 mm	2 m 3-Pin Pico QD	LO	VSM5AN6CV50 VSM5AN6CV50Q7	VSM5AP6CV50 VSM5AP6CV50Q7



 Connection options: A model with a QD requires a mating cordset.

Pico QD (for Q models)
Straight connector models listed; for right-angle, **W** replaces **G** in the model number. (example, **PKW3M-2**)



3-Pin
PKG3M-2
2 m (6')
PKG3M-5
5 m (15')
PKG3M-9
9 m (30')



SMBVSM4

Additional cordset information is available
See page 758

VSM Specifications

Supply Voltage and Current	10 to 30 V dc (10% max. ripple)
Supply Protection Circuitry	Protected against reverse polarity and transient voltages
Output Configuration	Single-output: 1 NPN or 1 PNP, Light Operate (LO) or Dark Operate (DO), depending on model
Output Rating	100 mA max. OFF-state leakage current: less than 1 µA ON-state saturation voltage: less than 2 V @ 100 mA
Output Protection Circuitry	Protected against false pulse on power-up and continuous overload or short circuit of outputs Overload trip point ≥ 100 mA
Response Time	2.5 milliseconds
Delay at Power-up	20 milliseconds
Repeatability	1 millisecond
Indicators	Yellow LED: light sensed
Construction	300 series stainless steel with PVC cable CV10 & CV20: sapphire lens CV50 & Opposed: Glass lens
Environmental Rating	IP67
Connections	2 m PVC-jacketed cable or 3-pin Pico-style integral QD (Q7), depending on model. QD cordsets ordered separately.
Operating Conditions	Operating temperature: 0° to +55 °C

Certification



M18-4

Heavy-Duty 18 mm Metal Barrel-Mount



- Chemically robust stainless steel sensors for washdown applications
- Robust housing is sealed against fluid ingress and exposure to harsh chemicals
- Powerful and bright visible red emitter beam for easy alignment and setup
- Highly visible output and dual-function power and stability indicators
- Advanced ASIC technology is resistant to fluorescent light and offers exceptional cross talk immunity
- Robust 250° adjustment potentiometer on select models
- Available in Emitter/Receiver, Polarized Retroreflective, Retroreflective, Diffuse, and Fixed Field models

M18-4

Example Model Number M18-4VPFF50-Q8

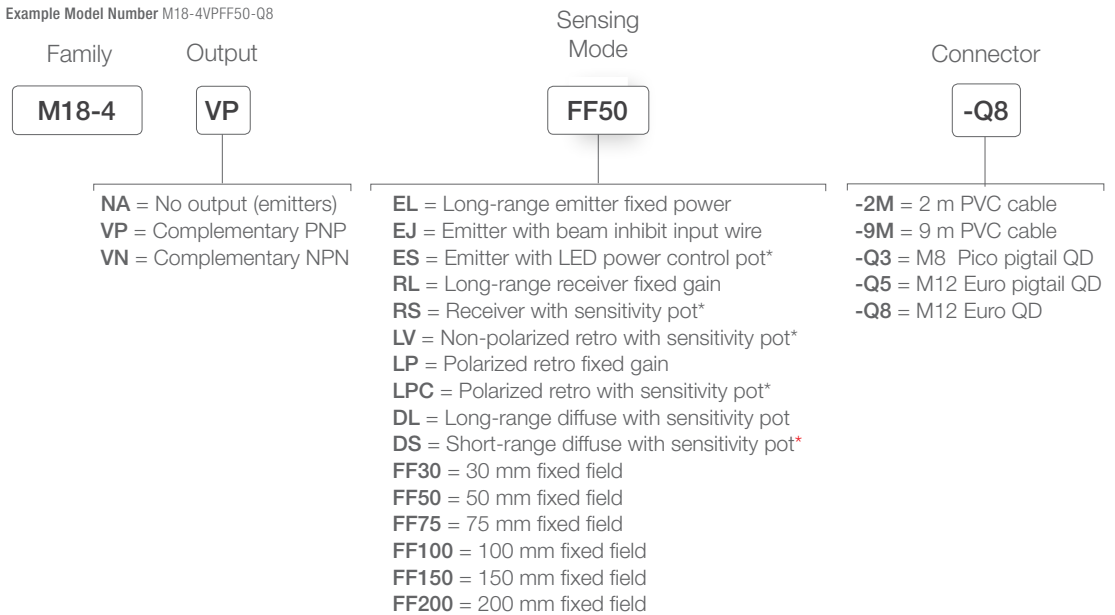

* Sensitivity adjustment

 Connection options: A model with a QD requires a mating cordset.

† Retroreflective range is specified using one model BRT-3 retroreflector, unless otherwise noted.

Actual sensing range may differ, depending on the efficiency and reflective area of the retroreflector used. See Accessories section for more information.



Euro-Style Cordsets
Straight connector models listed; for right-angle, add **RA** to the end of the model number (example, **MQDC-406RA**)

4-Pin
MQDC-406
2 m (6.5')
MQDC-415
5 m (15')
MQDC-430
9 m (30')



M12/Euro-Style Washdown (IP69K)
Straight connector models only

4-Pin
MQDC-WDSS-0406
2 m (6.5')
MQDC-WDSS-0415
5 m (15')
MQDC-WDSS-0430
9 m (30')

Additional cordset information is available
See page 758



SMB18FA..



SMB18A



SMB18SF

Additional bracket information is available
See page 725

Reflectors



Apertures





Additional information is available
See page 790

Additional information is available
See page 816



M18-4

M18-4 Specifications

Supply Voltage and Current	10 V to 30 V dc for ambient temperature $\leq 55\text{ }^{\circ}\text{C}$	10 V to 24 V dc for ambient temperature $> 55\text{ }^{\circ}\text{C}$
Supply Protection Circuitry	Protected against reverse polarity and transient voltages	
Output Configuration	Solid-state complementary dc switch; NPN (current sinking) or PNP (current sourcing), depending on model The Dark Operate (DO) output may be wired as a normally open marginal signal alarm output, depending upon hookup to the power supply	
Output Rating	$\leq 50\text{ mA}$ total current for ambient temperatures $> 55\text{ }^{\circ}\text{C}$ OFF-State Leakage Current: $< 50\text{ }\mu\text{A}$ at 30 V dc	$\leq 100\text{ mA}$ total current through both outputs $\leq 55\text{ }^{\circ}\text{C}$ ON-State Saturation Voltage: $< 1.5\text{ V}$ at 10 mA; $< 3.0\text{ V}$ at 100 mA
Output Protection Circuitry	Protected against false pulse on power-up and continuous short circuit of outputs. Short circuit protection at elevated temperature may require a power cycle to reset.	
Output Response Time	Opposed, Fixed Field: 1.5 milliseconds ON, 1.5 milliseconds OFF Polarized Retroreflective, Retroreflective, Fixed-field and Diffuse: 1.5 milliseconds ON, 0.75 milliseconds OFF Delay on Power-up: 100 milliseconds; outputs do not conduct during this time	
Delay at Power-up	100 milliseconds; outputs are non-conducting during this time	
Repeatability	Opposed: 170 microseconds Polarized Retroreflective, Retroreflective, Diffuse, Fixed Field: 100 microseconds Repeatability and response are independent of signal strength	
Indicators	Three LEDs (1 green, 2 amber) Green solid: indicates power applied and sensor ready Green flashing: indicates marginal sensing signal Amber solid: indicates Pin 4 (black wire) output conducting	
Emitter LED	Visible red	
Construction	Housing: 316L stainless steel Front window: PMMA	Indicator windows: Clear polysulfone (PSU) Indicator cover and gain pot driver: Black PSU
Environmental Rating	IEC 60529 IP67, IP68, and IP69K	
Operating Conditions	Temperature: -40° to $+70\text{ }^{\circ}\text{C}$	Relative humidity: 95% at $50\text{ }^{\circ}\text{C}$ (non-condensing)
Vibration and Mechanical Shock	All models meet Mil. Std. 202F requirements. Method 201A (Vibration; frequency 10 to 60 Hz, max., double amplitude 0.06 in acceleration 10G). Method 213B conditions H&I (Shock: 75G with unit operating; 100G for non-operation)	
Certifications	 	



Clear Object

Clear object detection sensors reliably and quickly detect clear, transparent and mirror-like surfaces with various visible red laser or ultrasonic sensor models for high precision detection.

Series	Description	Max Sensing Range	Dimensions H x W x D	Protection Rating	Housing Material	Power Supply
	QS18 The QS18E features a polarized coaxial optical design to ensure reliable detection of clear targets and has a fast 400 microsecond response time. page 312	3 m	34.5 x 15 x 31 mm	IP67	ABS	10 to 30 V dc
	Q4X COD The Q4X sensor solves many challenging applications and comes in a rugged IP69K rating with FDA food grade stainless steel casing. page 314	300 mm	44 x 22 x 33 mm	IP67 IP68 IP69K	Stainless Steel	12 to 30 V dc
	QS30 The QS30 reliably detects clear, translucent and opaque objects faster than other clear object detection sensor options. page 316	Retro: 2 m	44 x 22 x 33 mm	IP67	ABS	10 to 30 V dc
	Q26 Coaxial optics enable reliable detection of clear, translucent or opaque objects including mirror-like surfaces. page 318	Coaxial Polar Retro: 800 mm	52.3 x 45 x 25 mm	IP67	ABS	12 to 30 V dc
	OMNI-BEAM Modular self-contained photoelectric sensors can be customized for specific applications and offer reliable clear object detection. page 320	Polar Retro: 4 m	H (varies by model) 44.5 x 54.6 mm	IP66	Thermoplastic polyester	10 to 30 V dc
	MINI-BEAM Universal housing design with 18 mm threaded lens; an ideal replacement for other sensor styles. page 322	Polar Retro: 1 m	33.3 x 12.53.1 mm	IP67	Thermoplastic polyester	10 to 30 V dc

OTHER AVAILABLE MODELS



QS18U page 236



Q4X page 34



T18U page 226



T30UX page 224



QM26 page 298



QMH26 page 300

QS18

Clear Object Detection Sensor



- Polarized coaxial optical design ensures reliable detection of transparent, translucent, and opaque targets at any distance between sensor and reflector
- Suitable for low contrast sensing application: PET bottles, glass containers, shrink wrap
- Detect surfaces such as: LCD panels with built in polarizing films, solar panels, and semiconductor wafers
- IO-Link option available

QS18 COD Expert

Example Model Number: QS18EN6XLPCQ8

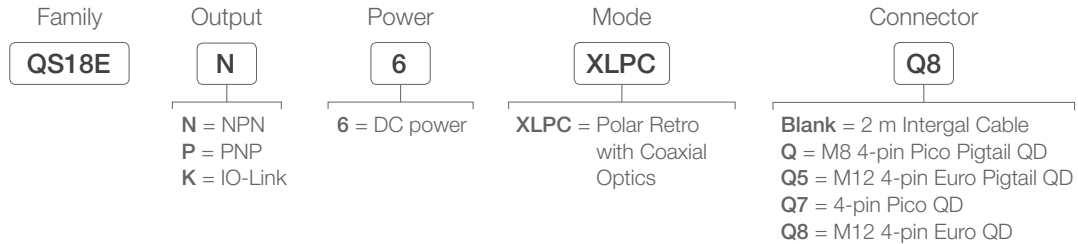

QS18 COD with Potentiometer

Example Model Number: QS18VN6XLPCQ8

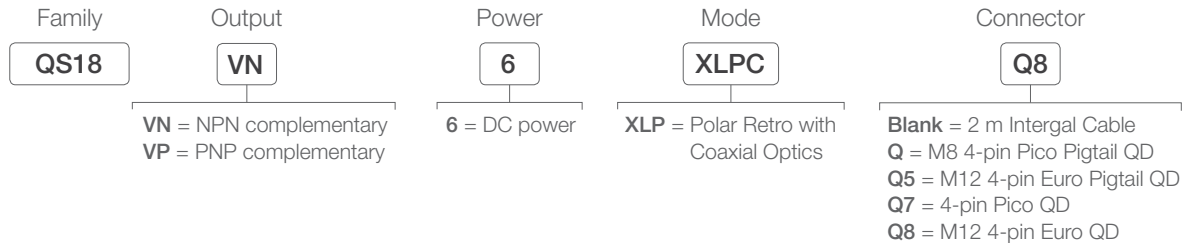

Connection options: A model with a QD requires a mating cordset.

Euro QD
(for ..Q8 or ..Q5 models)
Straight connector models listed; for right-angle, add **RA** to the end of the model number (example, **MQDC-406RA**)



4-Pin
MQDC-406
2 m (6')
MQDC-415
5 m (15')
MQDC-430
9 m (30')

Pico QD
Straight connector models listed; for right-angle, change **G** to **W** (example, **PKW4M-2**)



4-Pin
PKG4M-2
2 m (6')
PKG4M-5
5 m (15')
PKG4M-9
9 m (30')



Additional cordset information is available
See page 758



SMB18A



SMBQ4XFA
Includes 3/8" bolt for mounting

SMBQ4XFAM10
Includes 10 mm bolt for mounting

SMBQ4XFAM12
Clamps directly onto industry standard bracket systems of 1/2" or 12 mm rods

Reflectors



Additional information is available
See page 790

Additional bracket information is available
See page 722

QS18 Clear Object Specifications

Supply Voltage	10 to 30 V dc (10% max. ripple) at less than 35 mA, exclusive of load; 10 to 24 V dc @ greater than 55° C
Supply Protection Circuitry	Protected against reverse polarity and transient voltages
Output Configuration	Solid-state NPN (current sinking) or PNP (current sourcing), depending on model Light (LO) or Dark Operate (DO) selectable Selectable 30 millisecond output OFF-delay Rating: 100 mA max. OFF-state leakage current: less than 50 µA @ 30 V dc ON-state saturation voltage: less than 1.5 V (2 m cable); 1.7 V (9 m cable) Protected against false pulse on power-up and continuous overload or short circuit of output
Output Response Time	400 microseconds ON/OFF
Delay at Power-up	Momentary delay on power-up; outputs do not conduct during this time
Repeatability	100 microseconds
Adjustments	Thresholds: Push-button/remote-wire configurable Expert™-style TEACH and SET options: Light/Dark Operate: selectable by programming order (load output follows the first taught target condition) Push-button enable/disable: remote wire only See datasheet for detailed information
Indicators	2 LED indicators: Green: RUN mode, output short-circuit Yellow: Output ON/marginal, TEACH mode
Construction	ABS housing
Environmental Rating	Meets NEMA 6; IEC IP67; UL Type 1
Operating Conditions	Temperature: -20 to +70 °C Relative humidity: 90% @ 50 °C (non-condensing)

Certifications



Q4X Series

Clear Object Detection Sensor



- A simple user experience from installation to setup
 - Bright spot alignment
 - Three push buttons simplify setup
 - Intuitive menus
- Four-digit display shows percent match
- FDA-grade stainless steel is suitable for IP69K washdown environments

Q4X COD Threaded Barrel

Example Model Number: Q4XTBCOD300-Q8

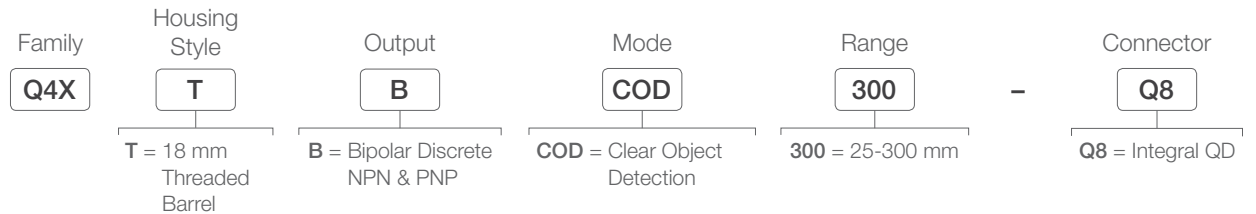

Q4X COD Flush Mount

Example Model Number: Q4XFNCOD310-Q8

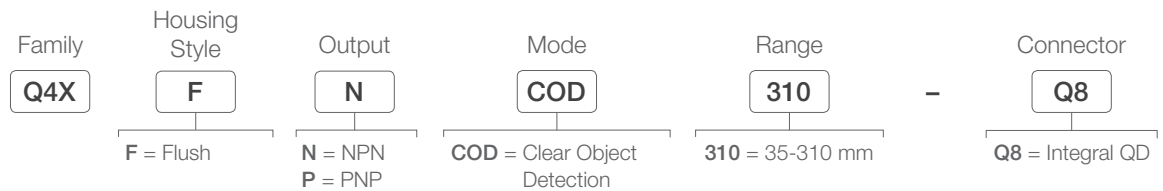

Q4XT.. models



Q4XF.. models

 Connection options: A model with a QD requires a mating cordset.



M12/Euro-Style
Straight connector models listed; for right-angle, add RA to the end of the model number (example, MQDC1-506RA)

5-Pin
MQDC1-506
2 m (6.5')
MQDC1-515
5 m (15')
MQDC1-530
9 m (30')



M12/Euro-Style Washdown (IP69K)
Straight connector models only

5-Pin
MQDC-WDSS-0506
2 m (6.5')
MQDC-WDSS-0515
5 m (15')
MQDC-WDSS-0530
9 m (30')

Additional cordset information is available
See page 758



SMB18A



SMBAMS18P



SMBAMS18RA



SMB46L2



SMBQ4XFA
includes 3/8" bolt for mounting

SMBQ4XFAM10
includes 10 mm bolt for mounting

SMBQ4XFAM12
clamps directly onto industry standard bracket systems of 1/2" or 12 mm rods

Additional bracket information is available
See page 722

Q4X Specifications

Supply Voltage and Current	10 to 30 V dc		
Laser Characteristics	Wavelength: Class 1 Laser: 655 nm visible red		
Beam Spot Size	Distance (mm)	Size (Horizontal x Vertical)	
	25/35	2.4 mm x 1.0 mm	
	50/60	2.32mm x 0.9 mm	
	100/110	1.8 mm x 0.7 mm	
Output Response Time	User selectable: 50 ms, 25 ms, 10 ms, 3 ms and 1.5 msw		
Excess Gain	HIGH Excess Gain (STANDARD Excess Gain)		
		Excess Gain (90% white card)	
	Response Speed (ms)	25/35 mm	300/310 mm
	1.5	200	20
	3	200	20
10	1000 (500)	100 (50*)	
25	2500 (1000)	250 (100*)	
50	5000 (2500)	500 (250*)	
Construction	Housing 316 L stainless steel; PMMA acrylic lens cover, Polysulfone lightpipe and display window		
Ambient Light Immunity	Greater than 5000 lux		
Environmental Rating	IP67 per IEC60529; IP68 per IEC60529; IP69K per DIN40050-9		
Operating Conditions	Temperature: -10 to +55 °C Humidity: 35% to 95% relative humidity		

Certifications



QS30

Right-Angle Clear Object Detection Sensors



- The QS30 reliably detects clear, translucent and opaque objects faster than other clear object detection sensor options
- Three selectable thresholds based on type of target being detected
- Easy configuration of sensor via push buttons or remote wire
- Rugged housing rated to IP67 NEMA 6

QS30 Expert™, 10-30 V DC

Visible Red LED

Sensing Mode	Laser Class	Range	Connection	Model Bipolar NPN/PNP
 CLEAR OBJECT	—	100 mm to 2 m†	2 m	QS30ELVC
			5-pin Euro QD	QS30ELVCQ
 RETRO				

Connection options: A model with a QD requires a mating cordset.

For 9 m cable, add suffix W/30 to the 2 m model number (example, QS30ELVC W/30).

† BRT-2X2LVC and BRT40X19A retroreflectors are included with sensor.



Euro-Style Cordsets
Straight connector models listed; for right-angle, add **RA** to the end of the model number (example, **MQDC1-506RA**)

5-Pin
MQDC1-506
2 m (6.5')
MQDC1-515
5 m (15')
MQDC1-530
9 m (30')



SMB30A



SMBQS30L



SMBQS30YL



SMBQS30Y

Additional cordset information is available
See page 758

Additional bracket information is available
See page 722

Reflectors



Additional information is available
See page 790

Apertures



Additional information is available
See page 816



Retroreflective Expert Models
Suffix ELVC

QS30 Expert™ Specifications

Supply Voltage and Current	10 to 30 V dc (10% max. ripple) at less than 25 mA, exclusive of load
Output Protection Circuitry	Protected against output short-circuit, continuous overload, transient over-voltages and false pulse on power-up
Sensing Beam	660 nm visible Red
Supply Protection Circuitry	Protected against reverse polarity; over voltage and transient voltages
Output Configuration	Bipolar: One NPN (current sinking) and one PNP (current sourcing); Light Operate (LO) or Dark Operate (DO) configurable
Output Response Time	500 microseconds
Delay at Power-up	250 milliseconds; outputs do not conduct during this time
Repeatability	150 microseconds
Adjustments	2 push buttons and remote wire for TEACH programming and configuration See data sheet for detailed information
Indicators	2 LEDs: Green: Power ON Yellow: Output conducting See data sheet for more detailed information
Construction	PC/ABS housing with acrylic lens cover
Environmental Rating	IEC IP67 (NEMA 6); PW12 1200 PSI washdown
Operating Conditions	Temperature: -10 to +55 °C Relative humidity: 95% @ 55 °C (non-condensing)
Vibration and Mechanical Shock	All models meet Mil. Std. 202F requirements. Method 201A (Vibration; frequency 10 to 60 Hz max., double amplitude 0.06-inch acceleration 10G). Also meets IEC 947-5-2 requirements: 30G, 11 milliseconds duration, half-sine wave.
Application Note	If supply voltage is > 24 V dc, derate maximum output current 1 mA/°C above 25° C



Q26

Clear Object Sensors



- Coaxial optics enable reliable detection of clear, translucent or opaque objects including mirror-like surfaces
- Simple setup with a single turn sensitivity adjustment potentiometer
- Compact design ideal when space is limited
- Rugged ABS housing with glass window

Q26

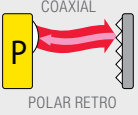
Sensing Mode	Range	Connection	Models NPN	Models PNP
 COAXIAL POLAR RETRO	5-800 mm sensor to reflector distance with no detection	4-pin Pico QD	Q26NXLPQ7	Q26PXLQ7
		4-pin Euro Pigtail QD	Q26NXLPQ5	Q26PXLQ5

 Connection options: A model with a QD requires a mating cordset.

For a 9 m cable, add suffix W/30 to the 2 m model number (example, Q26NXLPQ7 W/30)



Euro-Style Cordsets
Straight connector models listed; for right-angle, add **RA** to the end of the model number (example, **MQDC-406RA**)

4-Pin
MQDC-406
2 m (6.5')
MQDC-415
5 m (15')
MQDC-430
9 m (30')

Used with: Q models



Pico-Style Cordsets
Straight connector models listed; for right-angle, replace the **G** with a **W** in the model number (example, **PKW4M-2**)

4-Pin
PKG4M-2
2 m (6.5')
PKG4M-5
5 m (15')
PKG4M-9
9 m (30')

Used with: Q7 models

Additional cordset information is available
See page 758



SMBLSTDLQ26



SMBLSTQ26

Additional bracket information is available
See page 725

Reflectors



Additional information is available
See page 790

Apertures



Additional information is available
See page 816



Q26 Specifications

Supply Voltage and Current	12 to 30 V dc (10% maximum ripple within specified limits); supply current (exclusive of load current): 15mA
Supply Protection Circuitry	Protected against reverse polarity and transient voltages
Output Configuration	Primary output (pin 2) NPN or PNP (current sinking or sourcing), depending on model; second output (pin 4) is a Health mode output
Output Rating	100 mA max OFF-state leakage current: less than 1 microamp @ 30 V dc ON-state saturation voltage: less than 1 V @ 10 mA dc; less than 1.5 V @ 150 mA dc
Output Protection Circuitry	Protected against false power-up and continuous overload or short circuit of outputs
Output Response Time	250 μS ON and OFF
Repeatability	50 microseconds
Indicators	Green steady: Power ON Yellow steady: Output conducting
Construction	ABS plastic housing; glass window
Operating Conditions	Temperature: -10 ° to +55 °C Relative Humidity: 90% at 50 °C; non-condensing
Environmental Rating	Leakproof design rated IP67
Vibration and Shock	EN60068-2-6 and EN60068-2-27

Certifications



OMNI-BEAM™

Rectangular Modular Sensors



- Modular self-contained photoelectric sensors can be customized for specific applications and offer reliable clear object detection
- Includes a sensor head and power block with optional timing logic module
- Offers interchangeable AC or DC power blocks
- Features exclusive multiple-LED system that display received signal strength, sensing contrast and seven different warnings

OMNI-BEAM™ Sensor Heads

➔ Visible Red LED

Sensing Mode	Range	Supply Voltage	Response & Repeatability	Models
	4 m†	Provided by Power Block	Response: 4 ms Repeatability: 0.2 ms	OSBLVAGC

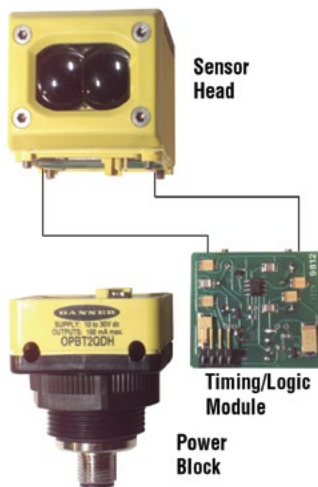

- STEP 1:** Choose a power block for the required sensor power (ac or dc) and interface.
- STEP 2:** Choose an timing logic module (Optional)
- STEP 3:** Plug and bolt components together without interwiring.

OMNI-BEAM modular components are sold separately. The three modular components, and the lenses, can be replaced in the field.

OMNI-BEAM™ Power Blocks

Connection	Supply Voltage	Output Type	Models
2 m	10-30 V dc	Bi-Modal™ NPN or PNP Two outputs: Load and Alarm	OPBT2
4-Pin Mini QD			OPBT2QD
4-Pin Euro QD			OPBT2QDH
2 m	10-30 V dc	No output: for powering emitter-only sensor heads	OPBTE
4-Pin Mini QD			OPBTEQD
4-Pin Euro QD			OPBTEQDH
2 m	105-130 V ac	SPST solid-state ac relay Two outputs: Load and Alarm	OPBA2
5-Pin Mini QD			OPBA2QD
2 m	210-250 V ac		OPBB2
5-Pin Mini QD			OPBB2QD
2 m	105-130 V ac	No output: for powering emitter only sensor heads	OPBAE
5-Pin Mini QD			OPBAEQD
2 m	210-250 V ac		OPBBE
5-Pin Mini QD			OPBBEQD

† Retroreflective range is specified using one model BRT-3 retroreflector. Actual sensing range may differ, depending on efficiency and reflective area of the retroreflector in use. See Accessories for more information.
NOTE: Sensor heads require a power block.

OMNI-BEAM™ Timing Logic Modules

Type	Logic Function	Timing Ranges	Models
Delay Timer Logic Module	ON-DELAY or OFF-DELAY or ON/OFF DELAY	ON-Delay: 0.01-1 sec., 0.15-15 sec., or none OFF-Delay: 0.01-1 sec., 0.15-15 sec., or none	OLM5
Pulse Timer Logic Module	ONE-SHOT pulse timer or DELAYED ONE-SHOT logic timer	Delay: 0.01-1 sec., 0.15-15 sec., or none Pulse: 0.01-1 sec., 0.15-15 sec.	OLM8



For information on Timing Diagrams, see data sheet

Connection options: A model with a QD requires a mating cordset.
 For 9 m cable, add suffix W/30 to the 2 m model number (example, OPBT2 W/30).

Euro-Style Cordsets
Straight connector models listed; for right-angle, add **RA** to the end of the model number (example, **MQDC-406RA**)

	4-Pin MQDC-406 2 m (6.5') MQDC-415 5 m (15') MQDC-430 9 m (30')
--	---

Mini-Style Cordsets
Straight connector models listed

	4-Pin MBCC-406 2 m (6.5') MBCC-415 5 m (15') MBCC-430 9 m (30')	5-Pin MBCC-506 2 m (6.5') MBCC-515 5 m (15') MBCC-530 9 m (30')
--	---	---

Additional cordset information is available
See page 758



SMB30A



SMB30FA..

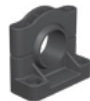

SMB30SC

Additional bracket information is available
See page 737

Reflectors

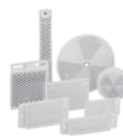

Additional information is available
See page 790

OMNI-BEAM™ Specifications

See website for more details www.bannerengineering.com

MINI-BEAM®

Clear Object Sensor with Mounting Versatility



- Universal housing design with 18 mm threaded lens; an ideal replacement for hundreds of other sensor styles. Available in eight modes with a compact housing for limited space setups
- Versatile sensor with several mounting options
- Meets IP67 and NEMA 6 standards for harsh environment
- Universal housing design

MINI-BEAM® *Expert*, 10-30 V DC

Visible Red LED

Sensing Mode	Range	Connection	Output	Models
<p>CLEAR OBJECT</p> <p>POLAR RETRO</p>	1 m	2 m	Bipolar NPN/PNP	SME312LPC*
		5-Pin Euro QD		SME312LPCQD*

Connection options: A model with a QD requires a mating cordset.

For 9 m cable, add suffix W/30 to the 2 m model number (example, SME312D W/30).

* NOTE: For clear object detection, sensing range varies, according to the efficiency and reflective area of the retroreflector(s) used.

For these low-contrast applications, the model BRT-2X2 reflector is recommended and is included with each SME312LPC(QD) sensor.

- For applications with high vibration, the model BRT-51X51BM, with its micro-prism geometry, is recommended.
- For long-range applications, the BRT-77X77C reflector provides a range up to 2 m.
- SME312LPC(QD) are for use with corner cube type reflectors only; reflective tape is not recommended.



Temperature

Temperature sensors are passive, non-contact sensors that are able to detect a change as small as 3 °C.

Series	Description	Temperature Measurement Range	Dimensions H x W x D	Protection Rating	Housing Material	Power Supply
	<p>M18T A small, self-contained design with easy to use TEACH mode programming. page 326</p>	0 to 300 °C	H (varies by model) ø18 mm	IP67	304 Stainless Steel	10 to 30 V dc

OTHER AVAILABLE MODELS



M12F page 264

M18T



Rugged Temperature Sensors

- The M18T has a small, self-contained design and has easy-to-use TEACH mode programming
- Rugged, encapsulated design for harsh environments
- Remote Teach available in both Static and Dynamic modes

Discrete M18T, 10-30 V DC

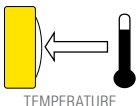
Sensing Mode	D:S Ratio*	Sensing Face	Connection	Output	Models
	8:1	Integrated lens	2 m 5-Pin Euro QD	Bipolar (NPN and PNP)	M18TB8 M18TB8Q
	6:1	Enclosed plastic face (for food industry use)	2 m 5-Pin Euro QD	Bipolar (NPN and PNP)	M18TB6E M18TB6EQ
	14:1	Germanium lens	2 m 5-Pin Euro QD	Bipolar (NPN and PNP)	M18TB14 M18TB14Q

Analog M18T, 12-30 V DC

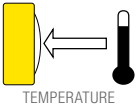
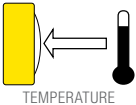
Sensing Mode	D:S Ratio*	Sensing Face	Connection	Output	Models
	8:1	Integrated lens	2 m 5-Pin Euro QD	0 to 10 V dc analog, plus PNP Alarm	M18TUP8 M18TUP8Q
	6:1	Enclosed plastic face (for food industry use)	2 m 5-Pin Euro QD	0 to 10 V dc analog, plus PNP Alarm	M18TUP6E M18TUP6EQ
	14:1	Germanium lens	2 m 5-Pin Euro QD	0 to 10 V dc analog, plus PNP Alarm	M18TUP14 M18TUP14Q
	8:1	Integrated lens	2 m 5-Pin Euro QD	4 to 20 mA analog, plus PNP Alarm	M18TIP8 M18TIP8Q
	6:1	Enclosed plastic face (for food industry use)	2 m 5-Pin Euro QD	4 to 20 mA analog, plus PNP Alarm	M18TIP6E M18TIP6EQ
	14:1	Germanium lens	2 m 5-Pin Euro QD	4 to 20 mA analog, plus PNP Alarm	M18TIP14 M18TIP14Q

 Connection options: A model with a QD requires a mating cordset.

For 9 m cable, add suffix W/30 to the 2 m model number (example, M18TB8 W/30).

* For D:S ratio information see page 327



Euro-Style with Shield
Straight connector models listed; for right-angle, add **RA** to the end of the model number (example, **MQDEC2-506RA**)

5-Pin
MQDEC2-506
2 m (6.5')
MQDEC2-515
5 m (15')
MQDEC2-530
9 m (30')

Additional cordset information is available
See page 758



SMB18A



SMB18SF

Additional bracket information is available
See page 723



M18T Specifications

Supply Voltage and Current	Discrete models: 10 to 30 V dc (10% max. ripple) Analog models: 12 to 30 V dc (10% max. ripple)																																														
Supply Protection Circuitry	Protected against short circuit conditions																																														
Output Rating	Analog Voltage: 2.5 kΩ minimum load resistance Analog Current: 1 kΩ max. @ 24 V input; max. load resistance = $[(V_{cc} - 4)/0.02]\Omega$ For current output (4-20mA models): Ideal results are achieved when the total load resistance $R = [(V_{in} - 4)/0.02]\Omega$ Example, at $V_{in} = 24\text{ V dc}$, $R \approx 1\text{ k}\Omega$ (1 watt) Alarm: Off-state leakage: < 10 microamps; Saturation: < 1.2 V @ 10 mA and < 1.6 V @ 100 mA																																														
Output Protection Circuitry	Protected against false pulse on power-up and continuous overload or short-circuit of outputs																																														
Sensing Field of View	Distance from Sensor Face Versus Sport Size <table border="1"> <thead> <tr> <th>D:S ratio</th> <th>100</th> <th>200</th> <th>300</th> <th>400</th> <th>500</th> <th>600</th> <th>700</th> <th>800</th> <th>900</th> <th>1000</th> <th>Distance (mm)</th> </tr> </thead> <tbody> <tr> <td>6:1</td> <td>17</td> <td>33</td> <td>50</td> <td>67</td> <td>83</td> <td>100</td> <td>117</td> <td>133</td> <td>150</td> <td>167</td> <td rowspan="3">Spot size (mm)</td> </tr> <tr> <td>8:1</td> <td>13</td> <td>25</td> <td>38</td> <td>50</td> <td>63</td> <td>75</td> <td>88</td> <td>100</td> <td>113</td> <td>125</td> </tr> <tr> <td>14:1</td> <td>7</td> <td>14</td> <td>21</td> <td>39</td> <td>36</td> <td>43</td> <td>50</td> <td>57</td> <td>64</td> <td>71</td> </tr> </tbody> </table>	D:S ratio	100	200	300	400	500	600	700	800	900	1000	Distance (mm)	6:1	17	33	50	67	83	100	117	133	150	167	Spot size (mm)	8:1	13	25	38	50	63	75	88	100	113	125	14:1	7	14	21	39	36	43	50	57	64	71
D:S ratio	100	200	300	400	500	600	700	800	900	1000	Distance (mm)																																				
6:1	17	33	50	67	83	100	117	133	150	167	Spot size (mm)																																				
8:1	13	25	38	50	63	75	88	100	113	125																																					
14:1	7	14	21	39	36	43	50	57	64	71																																					
Construction	Threaded Barrel: 304 stainless steel Push Button Housing: ABS/PC Push Button: Santoprene																																														
Environmental Rating	IEC IP67; NEMA 6																																														
Operating Conditions	Temperature: -20 to +70 °C																																														
Certification	CE (some models pending. Contact factory for additional information)																																														



Hazardous Area

Sensors for hazardous areas are ideal for environments or locations with possibility of fire or explosion. Extensive approvals ensure sensors are safe to use in classified areas or zones.

Series	Description	Max Sensing Range		Dimensions H x W x D	Protection Rating	Housing Material	Power Supply
	<p>MINI-BEAM® NAMUR Ideal for hazardous environments with approved switching amplifiers that have intrinsically safe input circuits. page 330</p>	<p>Opposed: 6 m Retro: 5 m Retro Polarized: 2 m Convergent: 43 mm Diffuse: 380 mm Glass/Plastic Fiber: Varies</p>		30.7 x 12.2 x 66 mm	IP67	Thermoplastic Polyester	5 to 15 V dc
	<p>Q45 NAMUR A specialized sensor for explosive environments meeting intrinsically safe standards to ensure it is safe for use in hazardous areas. page 336</p>	<p>Opposed: 6 m Retro: 9 m Retro Polarized: 6 m Convergent: 100 mm Diffuse: 1 m Glass/Plastic Fiber: Varies</p>		87.6 x 44.5 (D varies by model)	IP67	Thermoplastic Polyester	5 to 15 V dc
	<p>SMI30 An extremely rugged and powerful intrinsically safe barrel sensor designed for the most demanding hazardous area sensing applications. page 338</p>	<p>Opposed: 140 m</p>		ø30 x 102 mm	IP67	Thermoplastic Polyester	10 to 30 V dc

MINI-BEAM® NAMUR

Compact Sensors for Hazardous Areas



- The MIAD9 series NAMUR models are ideal for hazardous environments with approved switching amplifiers that have intrinsically safe input circuits
- Available in opposed, retroreflective, convergent, diffuse and fiber optic modes
- Infrared or visible red sensing beam
- Industry standard mounting holes

Opposed MINI-BEAM®

Infrared LED

Sensing Mode	Range	Connection	Output	Models
 OPPOSED	6 m	2 m 4-Pin Euro QD	—	MI9E Emitter MI9EQ Emitter
 OPPOSED	6 m	2 m 4-Pin Euro QD	Constant Current: ≤1.2 mA dark ≥2.1 mA light	MIAD9R MIAD9RQ

Retro & Polar Retro MINI-BEAM®

Visible Red LED

Sensing Mode	Range	Connection	Output	Models
 RETRO	5 m	2 m 4-Pin Euro QD	Constant Current: ≤1.2 mA dark ≥2.1 mA light	MIAD9LV MIAD9LVQ
 POLAR RETRO	50 mm - 2 m	2 m 4-Pin Euro QD	Constant Current: ≤1.2 mA dark ≥2.1 mA light	MIAD9LVAG MIAD9LVAGQ

For more specifications see page 333.

Connection options: A model with a QD requires a mating cordset (see page 332).

For 9 m cable, add suffix W/30 to the 2 m model number (example, MIAD9LV W/30).

Convergent MINI-BEAM®

➔ Visible Red LED

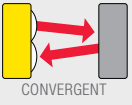
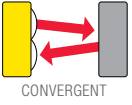
Sensing Mode	Range	Connection	Output	Models
 CONVERGENT	16 mm	2 m 4-Pin Euro QD	Constant Current: ≤1.2 mA dark ≥2.1 mA light	MIAD9CV MIAD9CVQ
 CONVERGENT	43 mm	2 m 4-Pin Euro QD	Constant Current: ≤1.2 mA dark ≥2.1 mA light	MIAD9CV2 MIAD9CV2Q

Diffuse MINI-BEAM®

➔ Infrared LED

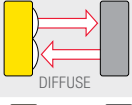
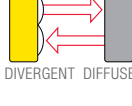
Sensing Mode	Range	Connection	Output	Models
 DIFFUSE	380 mm	2 m 4-Pin Euro QD	Constant Current: ≤1.2 mA dark ≥2.1 mA light	MIAD9D MIAD9DQ
 DIVERGENT DIFFUSE	75 mm	2 m 4-Pin Euro QD	Constant Current: ≤1.2 mA dark ≥2.1 mA light	MIAD9W MIAD9WQ

MINI-BEAM® NAMUR

➔ Infrared LED

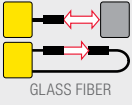
Sensing Mode	Range	Connection	Output	Models
 GLASS FIBER	Range varies by sensing mode and fiber optics used	2 m 4-Pin Euro QD	Constant Current: ≤1.2 mA dark ≥2.1 mA light	MIAD9F MIAD9FQ

For more specifications see page 333.

 Connection options: A model with a QD requires a mating cordset (see page 332).
For 9 m cable, add suffix W/30 to the 2 m model number (example, MIAD9LV W/30).

NAMUR Euro-Style
Straight connector models listed;
for right-angle, add **RA** to the end
of the model number
(example, **MQD9-406RA**)



4-Pin
MQD9-406
2 m (6.5')
MQD9-415
5 m (15')

*Additional cordset information is available
See page 758*



SMB312PD



SMB18FA



SMB312B

*Additional bracket information is available
See page 722*

Reflectors



*Additional information is available
See page 821*

Apertures





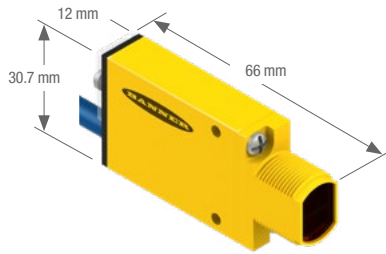

*Additional information is available
See page 816*



MINI-BEAM® NAMUR
Retroreflective, Diffuse and
Convergent Models
Suffix E, R, LV, D and CV

MINI-BEAM® NAMUR Specifications

Supply Voltage	5 to 15 V dc (provided by the amplifier to which the sensor is connected)
Output	Constant current output: ≤ 1.2 mA in the “dark” condition and ≥ 2.1 mA in the “light” condition
Output Response Time	Opposed receiver: 2 milliseconds ON/400 microseconds OFF All others: 5 milliseconds ON/OFF (does not include amplifier response)
Adjustments	GAIN (sensitivity) adjustment potentiometer
Indicators	Red LED Alignment Indicator Device (AID) located on rear panel lights when the sensor sees a “light” condition; pulse rate is proportional to signal strength (the stronger the signal, the faster the pulse rate).
Construction	Reinforced thermoplastic polyester housing, totally encapsulated, o-ring sealing, acrylic lenses and stainless steel screws
Environmental Rating	Meets NEMA standards 1, 2, 3, 3S, 4, 4X, 6, 12 and 13; IEC IP67
Operating Conditions	Temperature: -40 to +70 °C Relative humidity: 90% at 50 °C (non-condensing)
Design Standards	MIAD9 Series sensors comply with the following standards: DIN 19 234, EN 50 014 Part 1. 1977, EN50 020 Part 7. 1977, Factory Mutual #3610 and 3611, CSA 22.2 #157-92 and 22.2 #213-M1987
Certifications	    

APPROVALS			
CSA: #LR 41887	Intrinsically Safe, with Entity for: Class I, Groups A-D Class I, Div. 2, Groups A-D	FM: #J.I. 5Y3A4.AX	Intrinsically Safe, with Entity for: Class I, II, III, Div. 1, Groups A-G Class I, II, III, Div. 2, Groups A-D and G
KEMA: #03ATEX1441X	II IG EEx ia IIC T6	ETL: #553868	

Q45 NAMUR

Rectangular Sensors for Hazardous Areas



- The Q45 NAMUR is a specialized sensor for explosive environments meeting intrinsically safe standards to ensure it is safe for use in hazardous areas
- Intrinsically safe dc models for potentially explosive environments
- For use with approved DIN 19 234 switching amplifiers

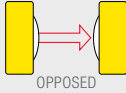

Opposed Q45, 5-15 V DC

 Infrared LED

Sensing Mode	Range	Connection	Output Type	Models
 OPPOSED	6 m	2 m	Constant Current ≤1.2 mA dark ≥2.1 mA light	Q459E Emitter
		4-Pin Euro QD		Q459EQ Emitter
		2 m		Q45AD9R
		4-Pin Euro QD		Q45AD9RQ

Retro & Polar Retro Q45, 5-15 V DC

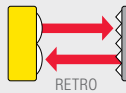
 Visible Red LED

Sensing Mode	Range	Connection	Output Type	Models
 RETRO	9 m [†]	2 m	Constant Current ≤1.2 mA dark ≥2.1 mA light	Q45AD9LV
		4-Pin Euro QD		Q45AD9LVQ
 POLAR RETRO	6 m [†]	2 m	Constant Current ≤1.2 mA dark ≥2.1 mA light	Q45AD9LP
		4-Pin Euro QD		Q45AD9LPQ

For more specifications see page 337.

 Connection options: A model with a QD requires a mating cordset (see page 336).

For 9 m cable, add suffix W/30 to the 2 m model number (example, Q459E W/30).

[†] Retroreflective range is specified using one model BRT-3 retroreflector.

Actual sensing range may differ, depending on efficiency and reflective area of the retroreflector in use. See Accessories for more information.

Diffuse Q45, 5-15 V DC

 Infrared LED

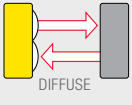
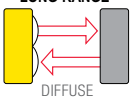
Sensing Mode	Range	Connection	Output Type	Models
 DIFFUSE	300 mm	2 m 4-Pin Euro QD	Constant Current ≤1.2 mA dark ≥2.1 mA light	Q45AD9D Q45AD9DQ
LONG-RANGE  DIFFUSE	1 m	2 m 4-Pin Euro QD	Constant Current ≤1.2 mA dark ≥2.1 mA light	Q45AD9DL Q45AD9DLQ

Convergent Q45, 5-15 V DC

 Visible Red LED

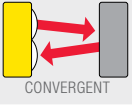
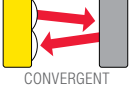
Sensing Mode	Range	Connection	Output Type	Models
 CONVERGENT	38 mm	2 m 4-Pin Euro QD	Constant Current ≤1.2 mA dark ≥2.1 mA light	Q45AD9CV Q45AD9CVQ
 CONVERGENT	100 mm	2 m 4-Pin Euro QD	Constant Current ≤1.2 mA dark ≥2.1 mA light	Q45AD9CV4 Q45AD9CV4Q

Glass & Plastic Fiber Q45, 5-15 V DC

 Infrared LED  Visible Red LED

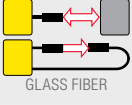
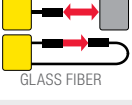
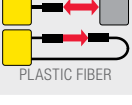
Sensing Mode	Range	Connection	Output Type	Models
 GLASS FIBER	Range varies by sensing mode and fiber optics used	2 m	Constant Current ≤1.2 mA dark ≥2.1 mA light	Q45AD9F
		4-Pin Euro QD		Q45AD9FQ
 GLASS FIBER	Range varies by sensing mode and fiber optics used	2 m	Constant Current ≤1.2 mA dark ≥2.1 mA light	Q45AD9FV
		4-Pin Euro QD		Q45AD9FVQ
 PLASTIC FIBER	Range varies by sensing mode and fiber optics used	2 m	Constant Current ≤1.2 mA dark ≥2.1 mA light	Q45AD9FP
		4-Pin Euro QD		Q45AD9FPQ

For more specifications see page 337.

 Connection options: A model with a QD requires a mating cordset (see page 336).

For 9 m cable, add suffix W/30 to the 2 m model number (example, Q459E W/30).



4-Pin

Euro-Style NAMUR
Straight connector models listed; for right-angle, add **RA** to the end of the model number (example, **MQD9-406RA**)

MQD9-406
2 m (6.5')
MQD9-415
5 m (15')



SMB30MM

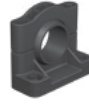

SMB30SC

*Additional cordset information is available
See page 758*

*Additional bracket information is available
See page 722*

Reflectors



*Additional information is available
See page 790*

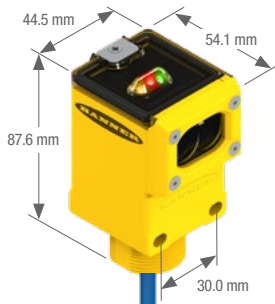

Opposed, Retroreflective and Diffuse Models
Suffix E, R, D, DL, LV and LP



Convergent Models
Suffix CV and CV4





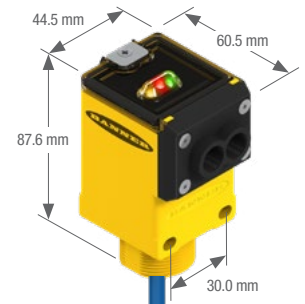

Plastic Fiber Model
Suffix FP



Glass Fiber Models
Suffix F and FV

Q45 NAMUR Specifications

Supply Voltage and Current	5 to 15 V dc. Supply voltage is provided by the amplifier to which the sensor is connected.
Output	Constant current output: ≤ 1.2 mA in the dark condition and ≥ 2.1 mA in the light condition
Output Response Time	Opposed receiver: 2 milliseconds ON/0.4 milliseconds OFF All others: 5 milliseconds ON/OFF (does not include amplifier response)
Adjustments	Multi-turn sensitivity control on top of sensor
Indicators	Power (Red): LED (emitters only) lights whenever 5 - 15 V dc power is applied Signal (Red): LED lights whenever the sensor sees its modulated light source
Construction	Molded thermoplastic polyester housing, o-ring sealed transparent Lexan® top cover, molded acrylic lenses, and stainless steel hardware. Q45s are designed to withstand 1200 psi washdown. The base of cabled models has a 1/2" NPS integral internal conduit thread.
Environmental Rating	IP67; NEMA 6P
Operating Conditions	Temperature: -40 to +70 °C Relative humidity: 90% at 50 °C (non-condensing)
Design Standards	Q45AD9 Series sensors comply with the following standards: DIN 19234, EN 50 014: 1977, EN 50 020: 2002
Certifications	    

Lexan® is a registered trademark of General Electric Co.

APPROVALS

CSA: #LR 41887	Intrinsically Safe, with Enty for Class I, Groups A-D Class I, Div. 2, Groups A-D	KEMA: #03 ATEX 1441x	II IG EEx ia IICTC
FM: #J.I. 5Y3A4.AX	Intrinsically Safe, with Enty for Class I, II, III, Div. 1, Groups A-G Class I, II, III, Div. 2, Groups A-D and G	ETL: #558044	Tested per FM and CSA as shown above

SMI30

Long-Range Barrel Sensors for Hazardous Areas



- The SMI30 is an extremely rugged and powerful intrinsically safe barrel sensor designed for the most demanding hazardous area sensing applications
- Certified as intrinsically safe for use in hazardous atmospheres as defined by Article 500 of the National Electrical Code, when used with approved "positive input" intrinsic safety barriers
- Certified by Factory Mutual and CSA as non-incendive devices when used in Division 2 locations (except Groups E and F) without intrinsic safety barriers

SMI30 Frequency A[†]
 Infrared LED

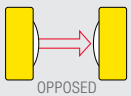
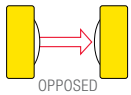
Sensing Mode	Range	Connection	Output Type	Response Time	Models
	140 m	3-Pin Mini QD	— NPN/LO NPN/DO	10 ms	SMI306EQ SMI30AN6RQ SMI30RN6RQ
	60 m	3-Pin Mini QD	— NPN/LO NPN/DO	1 ms	SMI306EYQ SMI30AN6RYQ SMI30RN6RYQ

Intrinsic Safety Kits for Use with SMI30 Intrinsically Safe Sensors

Model	Description
C12BK-1	Includes a CI3RC2 current amplifier, one RS-11 socket, one DIN-rail mount and one single-channel intrinsically safe barrier
C12BK-2	Includes a CI3RC2 current amplifier, one RS-11 socket, one DIN-rail mount and one dual-channel intrinsically safe barrier
CI3RC2	Current trip point amplifier
C1B-1	Single channel intrinsic safety barrier
C12B-1	Dual channel intrinsic safety barrier



Connection options: A model with a QD requires a special Mini-style mating cordset.

[†] Modulation frequency "A" is standard; frequencies "B" and "C" are also available to minimize optical crosstalk potential between adjacent pairs and are specified by adding "B" or "C" at the end of the standard model number (example, SMI306EBQ or SMI306ECQ).



Mini-Style
Straight connector models listed

3-Pin	4-Pin
SMICC-306	MBCC-406
2 m (6.5')	2 m (6.5')
SMICC-312	MBCC-412
4 m (12')	4 m (12')
SMICC-330	MBCC-430
9 m (30')	9 m (30')

Additional cordset information is available
See page 758



SMB30A



SMB30FA..

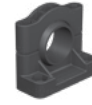

SMBAMS30P

Additional bracket information is available
See page 724

Reflectors



Additional information is available
See page 790





Apertures



Additional information is available
See page 816



SMI30 Specifications

Supply Voltage and Current	Emitters: 10 to 30 V dc at 25 mA Receivers: 10 to 30 V dc at 15 mA max. Division 1 use, with barriers, requires minimum system supply voltage of 10 V.
Supply Protection Circuitry	Protected against reverse polarity and transient voltages
Output Configuration	Receivers: Current sinking NPN open-collector transistor
Output Rating	Three-wire hookup sinks 15 mA max. continuous, 10 to 30 V dc. Two-wire hookup sinks ≤10 mA
Output Protection Circuitry	Outputs are short circuit protected
Output Response Time	10 milliseconds or 1 millisecond ON/OFF, depending on models; independent of signal strength
Repeatability	"A" frequency units: 10 millisecond receiver is 1 milliseconds and 1 millisecond receiver is 360 microseconds "B" frequency units: 1.6 milliseconds "C" frequency units: 10 millisecond receiver is 2.3 milliseconds and 1 millisecond receiver is 210 microseconds Repeatability is independent of signal strength
Indicators	Internal Red LED lights whenever the receiver sees the emitter's modulated light source. Emitters have Red "power on" indicator LED. All indicators are visible through the lens or from side of the sensor.
Construction	30 mm diameter tubular threaded thermoplastic polyester housing, fully epoxy-encapsulated, positive sealing at both ends, quad-ring sealed acrylic lens. Two thermoplastic polyester jam nuts provided.
Environmental Rating	IP67; NEMA 6P
Operating Conditions	Temperature: -40 to +70 °C Relative humidity: 90% at 50° C (non-condensing)
Certifications	   
Hookup Diagrams	See data sheet for detailed Hookup Diagrams.



Vision

Banner's extensive line of vision sensors helps you find defects earlier in the manufacturing process. Banner offers standard and high-resolution gray scale and color vision sensors. Add inspection capabilities where you need them.